



US00D681104S

(12) **United States Design Patent**
Yi et al.

(10) **Patent No.:** **US D681,104 S**
(45) **Date of Patent:** **** Apr. 30, 2013**

(54) **GUITAR HEADSTOCK**

(76) Inventors: **Kennon Yi**, Burbank, CA (US);
Sungmin Oh, Valencia, CA (US)

(**) Term: **14 Years**

(21) Appl. No.: **29/419,245**

(22) Filed: **Apr. 26, 2012**

(51) **LOC (9) Cl.** **17-03**

(52) **U.S. Cl.**
USPC **D17/20**

(58) **Field of Classification Search** D17/14,
D17/18, 19, 20; 84/173, 267, 290-293
See application file for complete search history.

(56) **References Cited**

U.S. PATENT DOCUMENTS

4,840,102	A *	6/1989	Pittman	84/293
D304,953	S *	12/1989	Ridinger et al.	D17/20
4,977,808	A *	12/1990	Thacker	84/291
D387,371	S *	12/1997	Riboloff	D17/20
D404,061	S *	1/1999	Roth	D17/20
D499,756	S *	12/2004	Di Pinto	D17/14
D572,302	S *	7/2008	Peavey	D17/20
D643,460	S *	8/2011	Barkdull	D17/20
D649,585	S *	11/2011	McCarthy	D17/20
D662,539	S *	6/2012	Mohajerin	D17/14

OTHER PUBLICATIONS

Neal Moser Guitars. http://www.nealmoserguitars.com/index.php?main_page=product_info&products_id=235. Copyright 2012. "Dolphin" Guitar Headstock.*

leihinstrumente.com. <http://www.leihinstrumente.com/Guitars/Electric-Guitars/Fernandes-Revolver-Elite-Stb/images/fernandes-revolver-elite-stb.html>. Date Unknown: Viewed Dec. 2012.*

* cited by examiner

Primary Examiner — Rashida Johnson

(74) *Attorney, Agent, or Firm* — Miles & Stockbridge P.C.;
David R. Schaffer, Esq.

(57) **CLAIM**

The ornamental design for a guitar headstock, as shown and described.

DESCRIPTION

FIG. 1 is a front view of a design for a guitar headstock. FIG. 2 is a right side view of a design for a guitar headstock. FIG. 3 is a bottom perspective view of a design for a guitar headstock. FIG. 4 is a back view of a design for a guitar headstock. FIG. 5 is a left side view of a design for a guitar headstock. FIG. 6 is a top perspective view of a design for a guitar headstock. FIG. 7 is a right side perspective view of a design for a guitar headstock; and, FIG. 8 is a bottom perspective view of a design for a guitar headstock. The broken lines shown throughout the views represent the portions of the guitar headstock, which form no part of the claimed design.

1 Claim, 4 Drawing Sheets

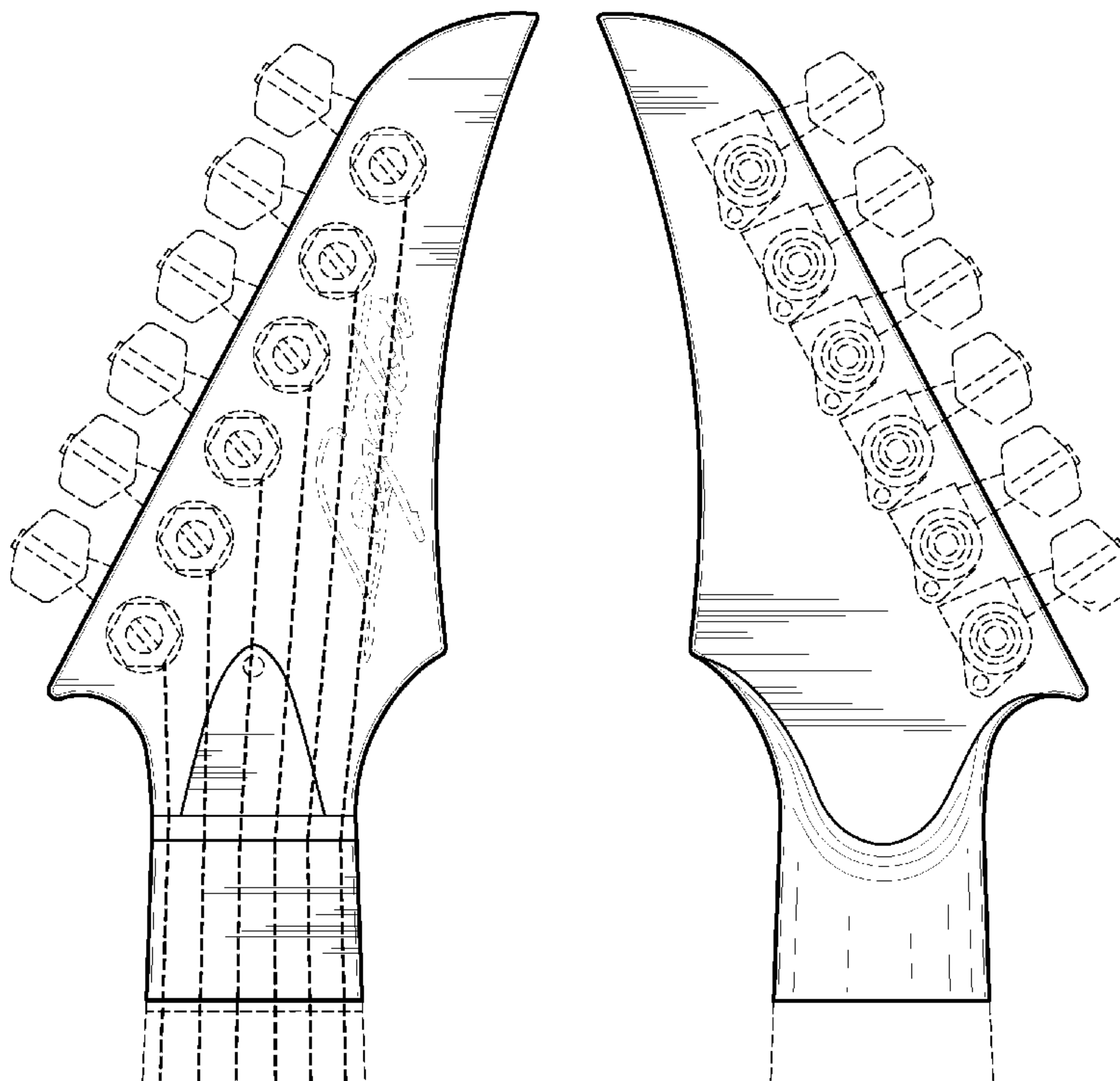

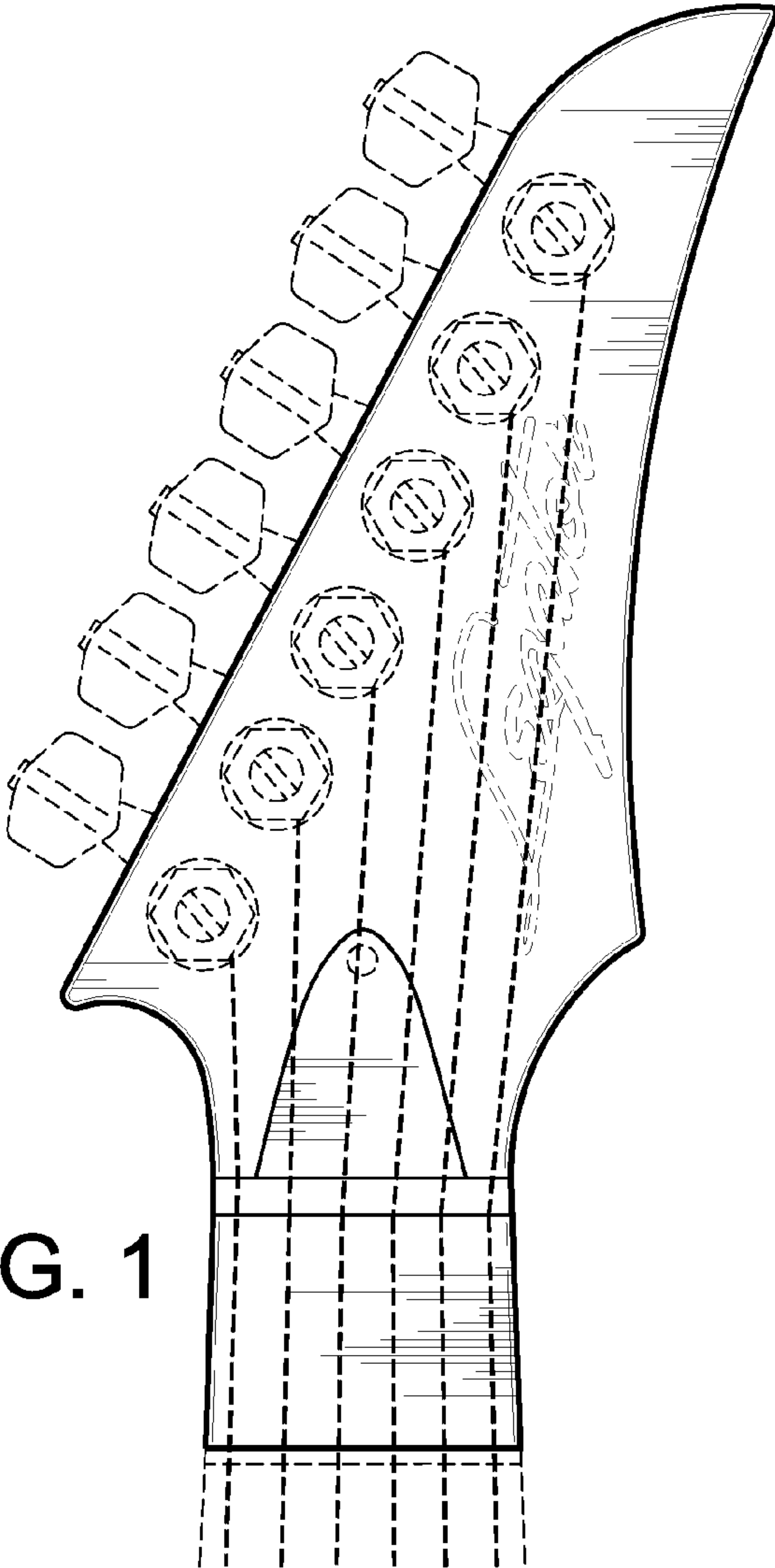

FIG. 1

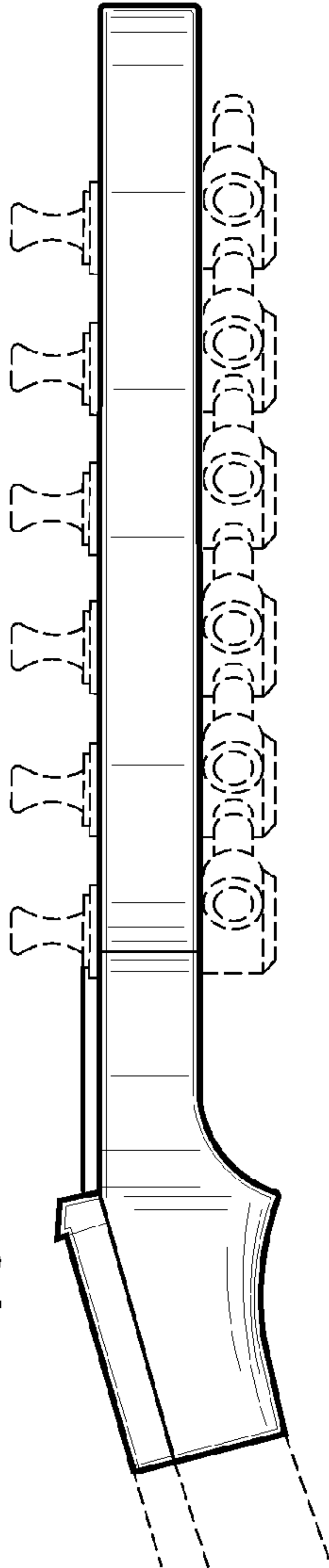

FIG. 2

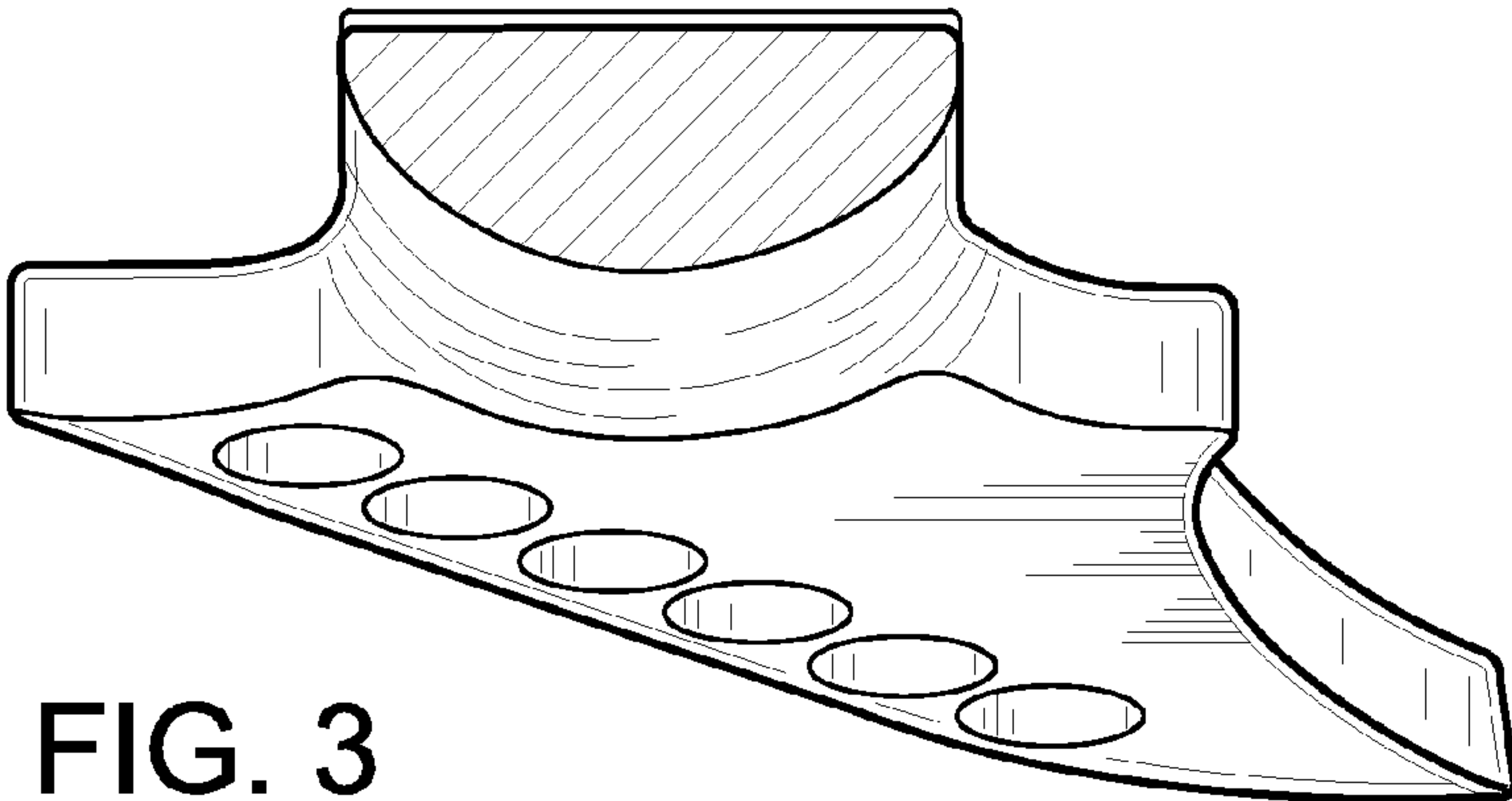

FIG. 3

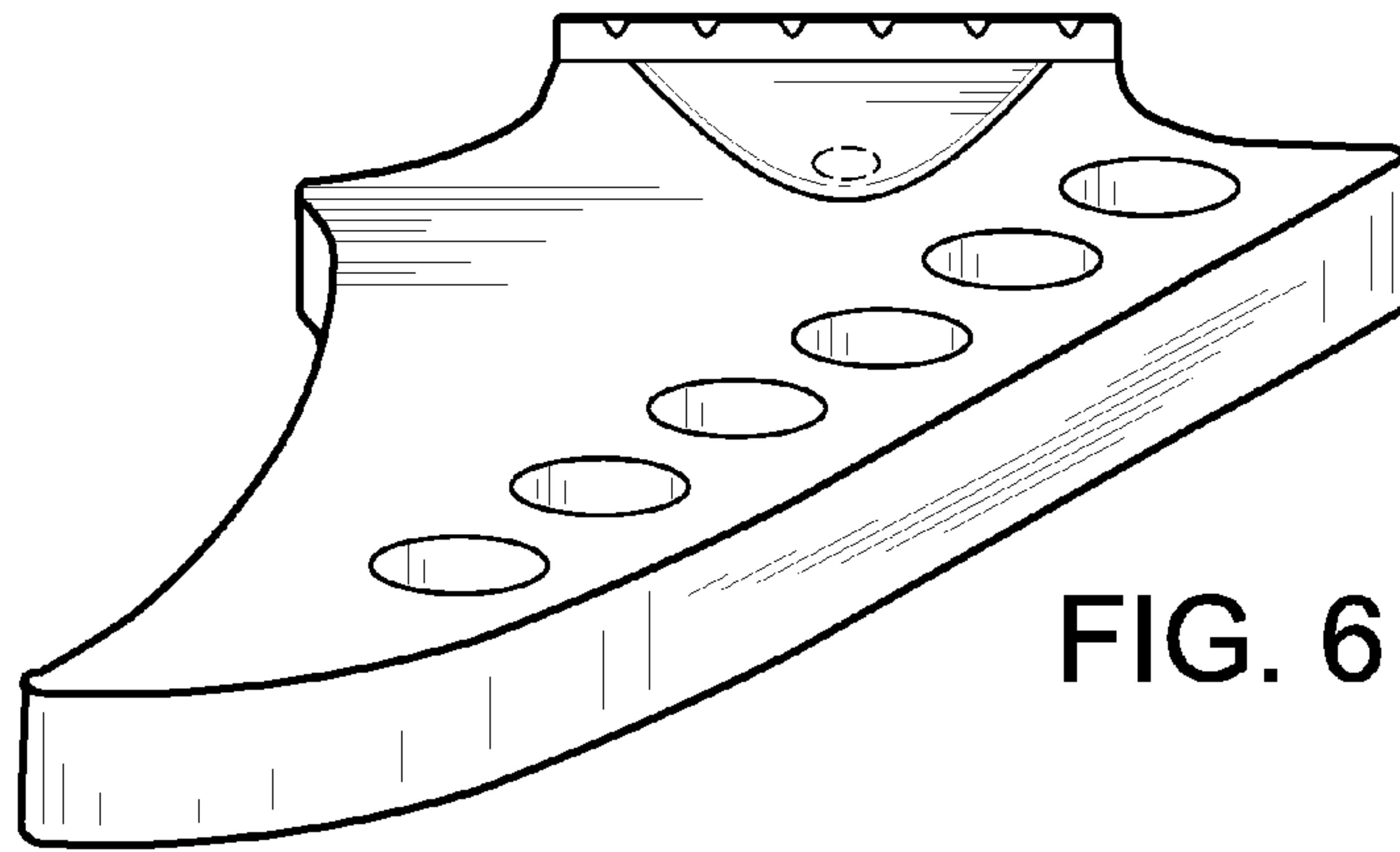

FIG. 6

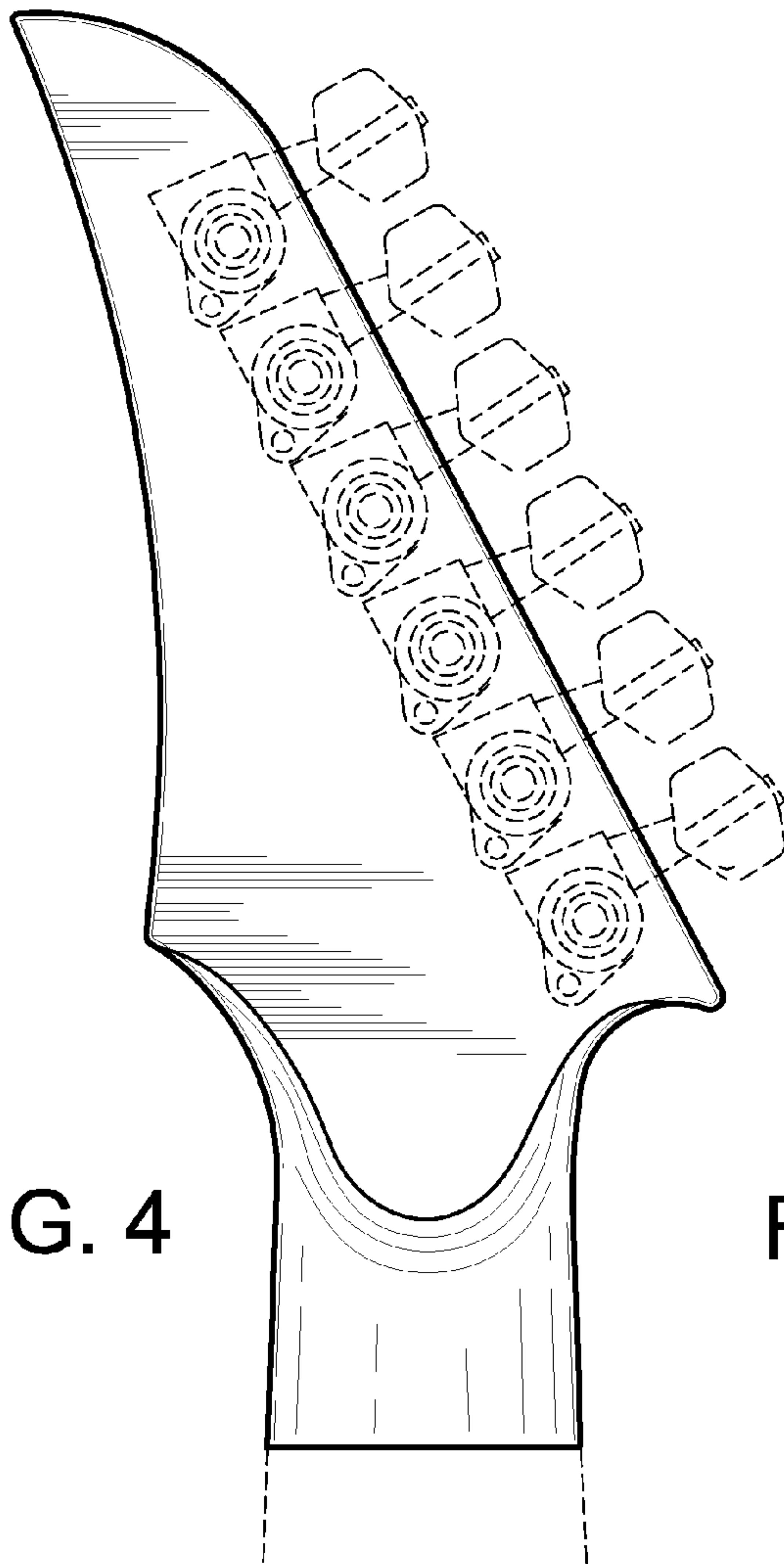

FIG. 4

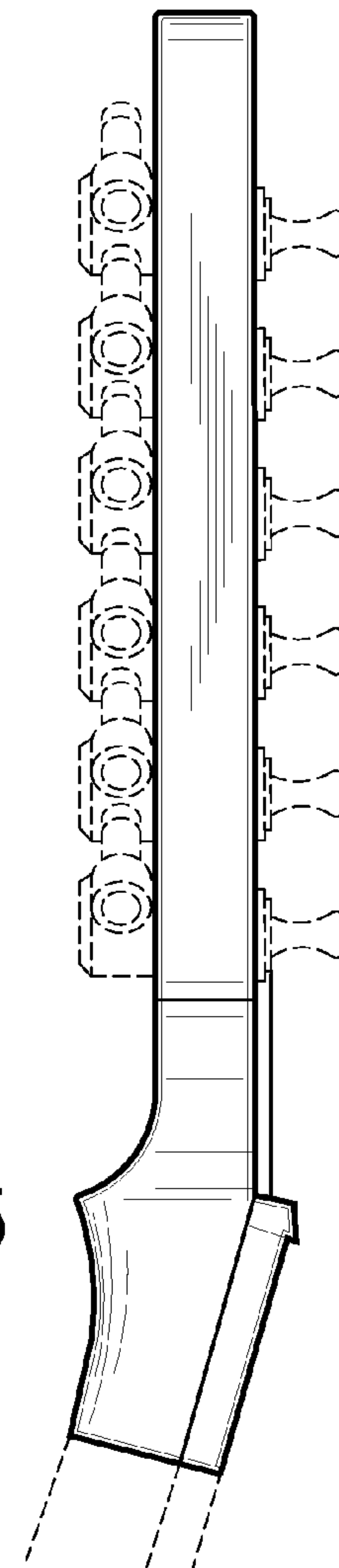

FIG. 5

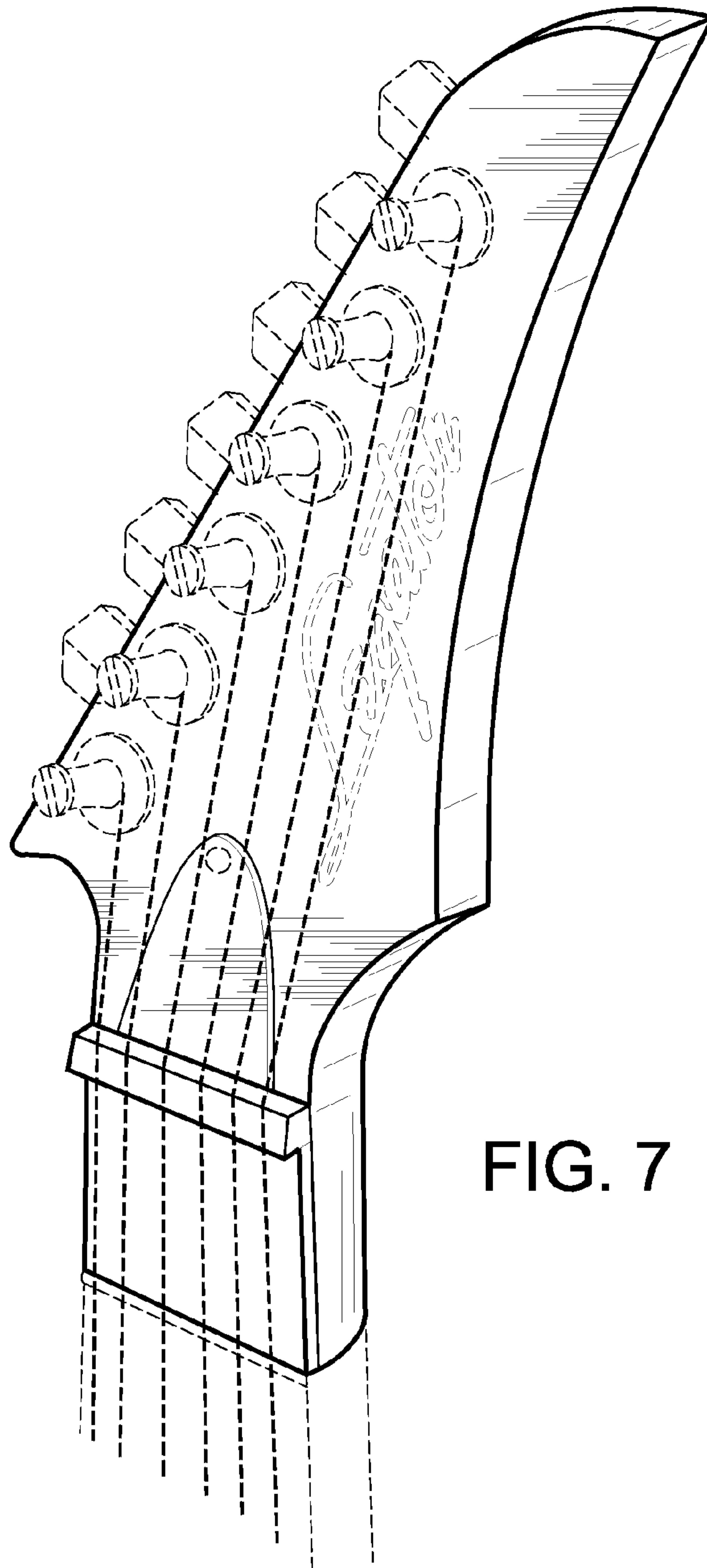

FIG. 7

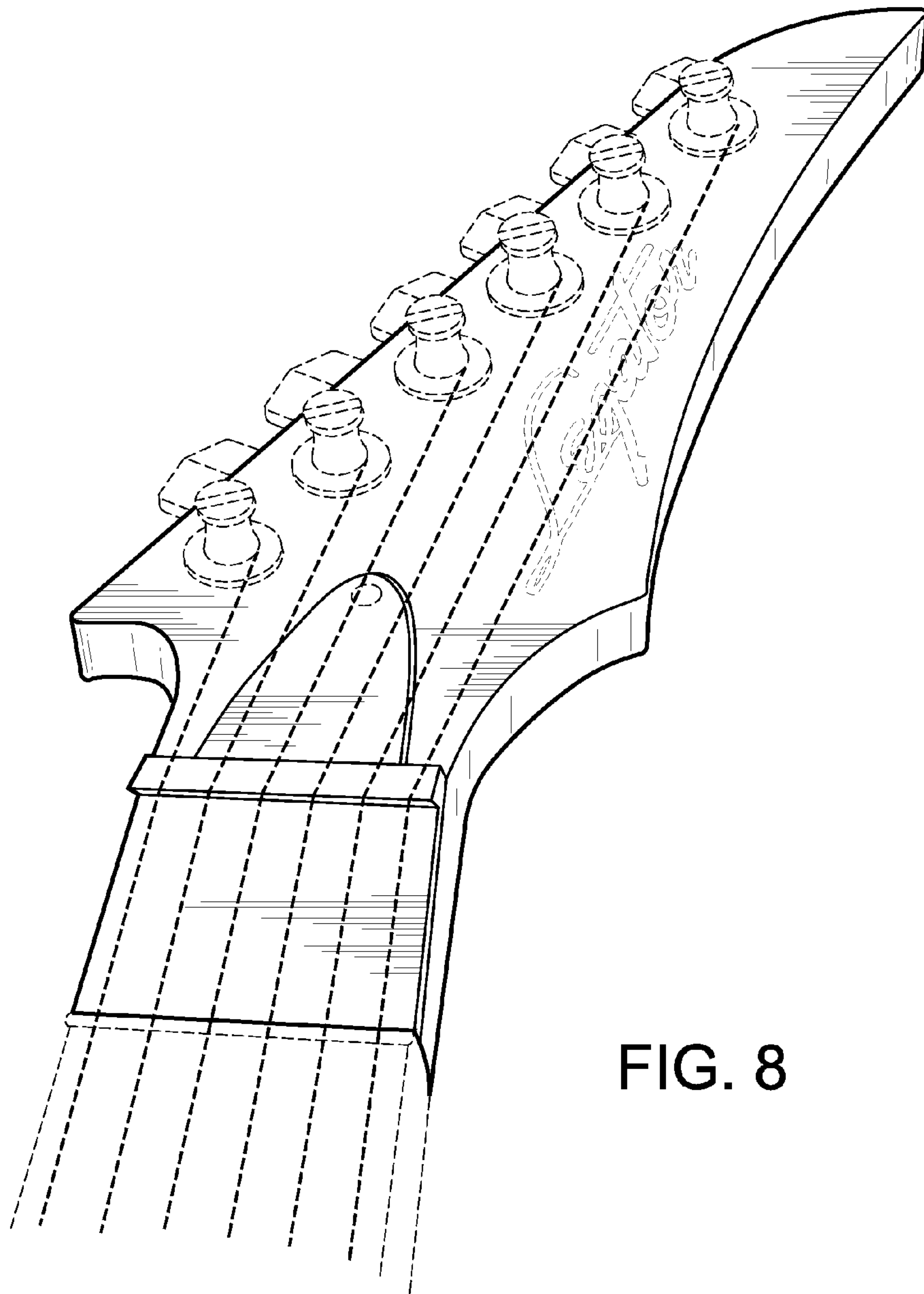

FIG. 8