



US00D680944S

(12) **United States Design Patent**  
**Aruga**

(10) **Patent No.:** **US D680,944 S**

(45) **Date of Patent:** **\*\* Apr. 30, 2013**

(54) **AIRCRAFT LUGGAGE COMPARTMENT**

(75) Inventor: **Hiroyasu Aruga**, Tokyo (JP)

(73) Assignee: **Mitsubishi Aircraft Corporation**,  
Aichi-Ken (JP)

(\*\*) Term: **14 Years**

(21) Appl. No.: **29/432,146**

(22) Filed: **Sep. 13, 2012**

(30) **Foreign Application Priority Data**

Mar. 21, 2012 (JP) ..... 2012-006337

(51) **LOC (9) Cl.** ..... **12-16**

(52) **U.S. Cl.**  
USPC ..... **D12/418**

(58) **Field of Classification Search** ..... D12/415-419,  
D12/96, 400, 195, 345, 99, 191, 106; 312/246;  
296/37.1-37.8, 70, 24.1, 24.2, 24.3, 137.1,  
296/97.1, 97.2, 97.4, 97.5, 97.6, 97.7, 97.8,  
296/180, 1; 224/311, 539, 281, 118.1, 275;  
D8/354; D14/451-452; 248/278.1, 274.1,  
248/284.1; D9/423; D3/319; 160/370.21,  
160/370.23, 370.22

See application file for complete search history.

(56) **References Cited**

**U.S. PATENT DOCUMENTS**

D245,414 S \* 8/1977 Ashbaugh et al. .... D12/418  
D251,838 S \* 5/1979 Derreberry ..... D12/418

D256,229 S \* 8/1980 Nichols ..... D12/418  
D281,930 S \* 12/1985 Engfer et al. .... D12/418  
D295,969 S \* 5/1988 Hooks et al. .... D12/424  
D314,739 S \* 2/1991 Mallone ..... D12/424  
D320,587 S \* 10/1991 Kapp et al. .... D12/418  
D541,730 S \* 5/2007 Vitito ..... D12/418  
D612,795 S \* 3/2010 Tirey et al. .... D12/418  
D613,234 S \* 4/2010 Tirey et al. .... D12/418

\* cited by examiner

*Primary Examiner* — Katrina A Betton

(74) *Attorney, Agent, or Firm* — Birch, Stewart, Kolasch &  
Birch, LLP

(57) **CLAIM**

The ornamental design for an aircraft luggage compartment,  
as shown and described.

**DESCRIPTION**

FIG. 1 is a perspective view from the front side of an aircraft  
luggage compartment.

FIG. 2 is a perspective view from the rear side thereof.

FIG. 3 is a front elevation view thereof.

FIG. 4 is a rear elevation view thereof.

FIG. 5 is a left side elevation view thereof.

FIG. 6 is a right side elevation view thereof.

FIG. 7 is a top plan view thereof.

FIG. 8 is a bottom plan view thereof; and,

FIG. 9 is a perspective view with the lid open.

**1 Claim, 9 Drawing Sheets**

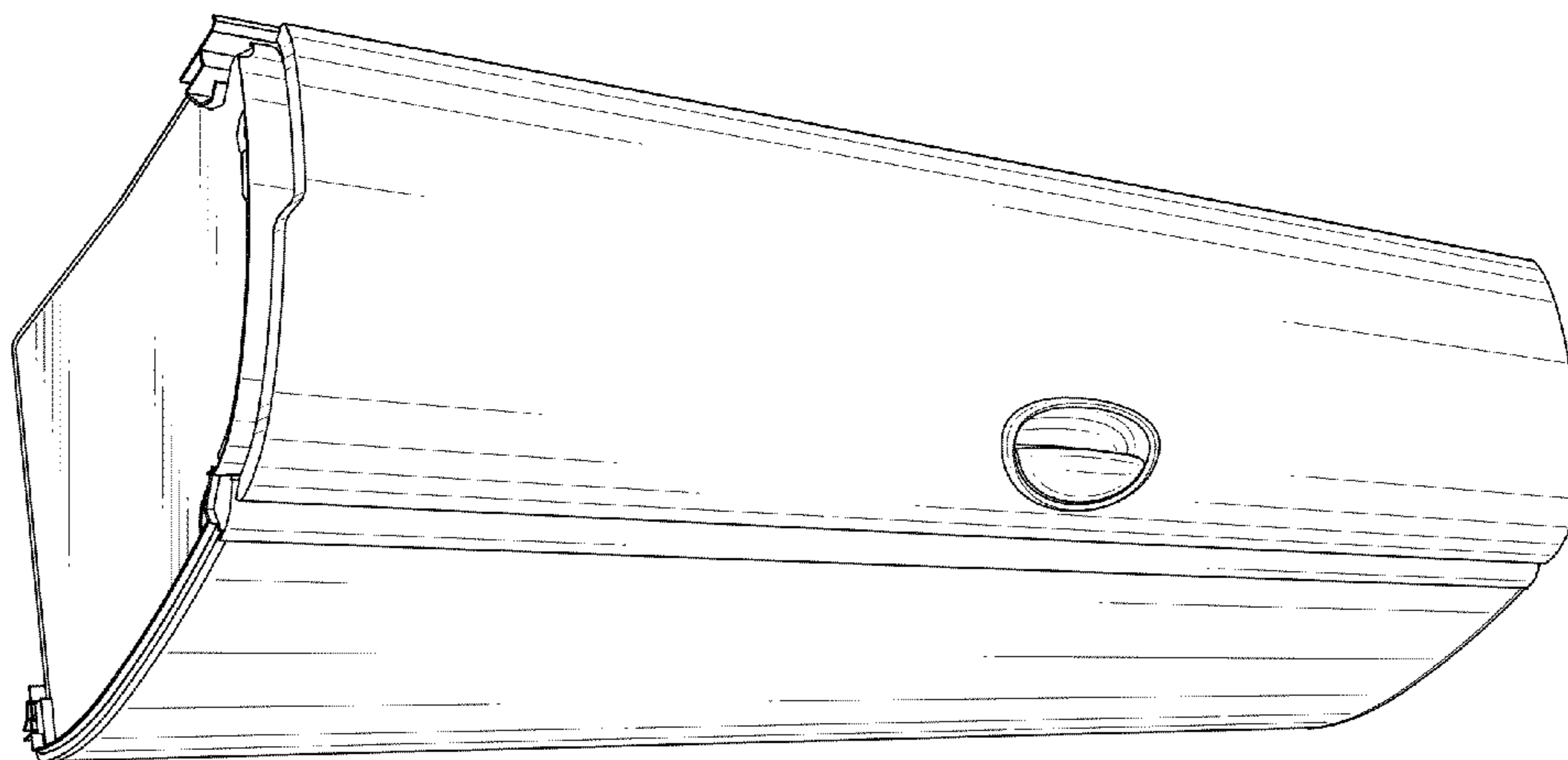

FIG. 1

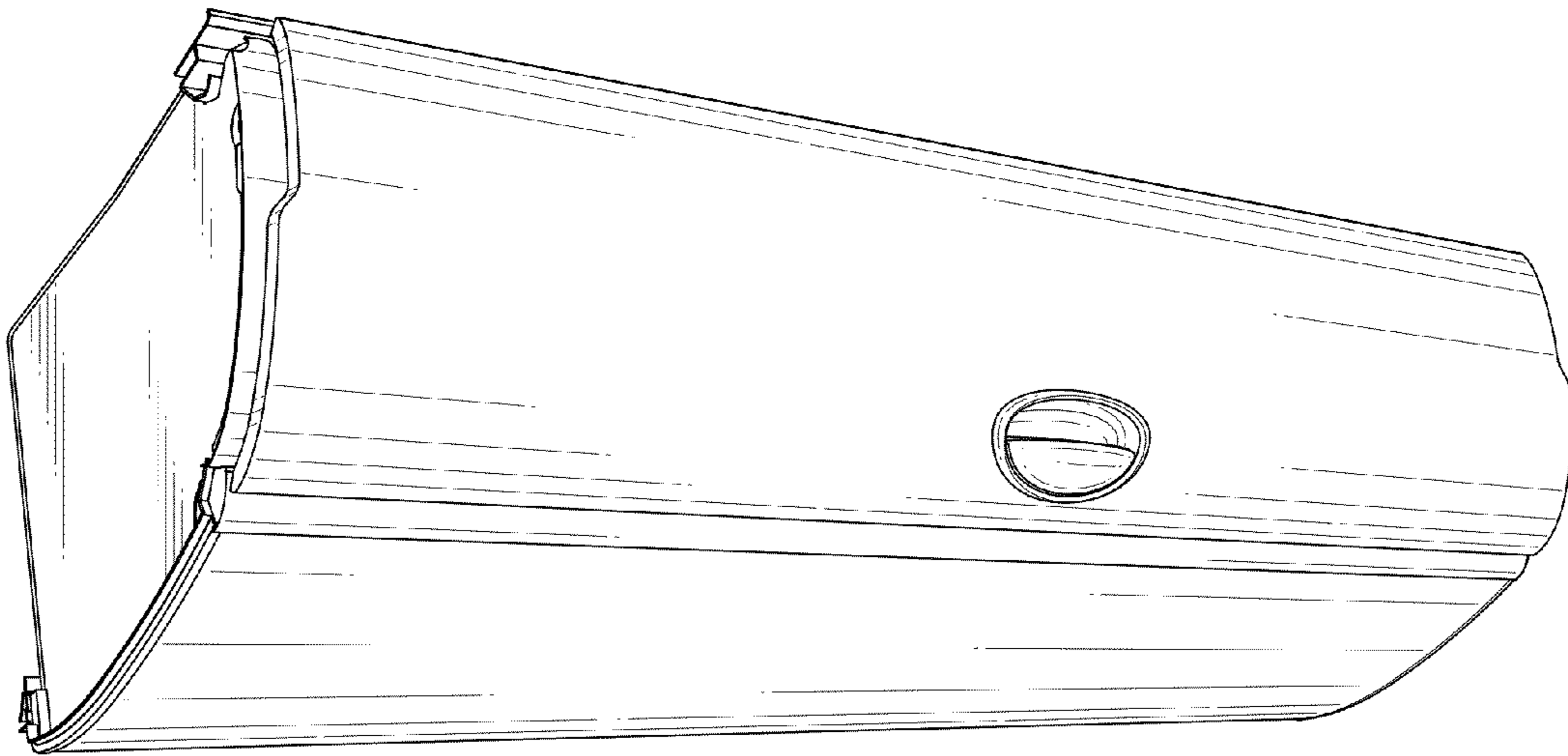

FIG. 2

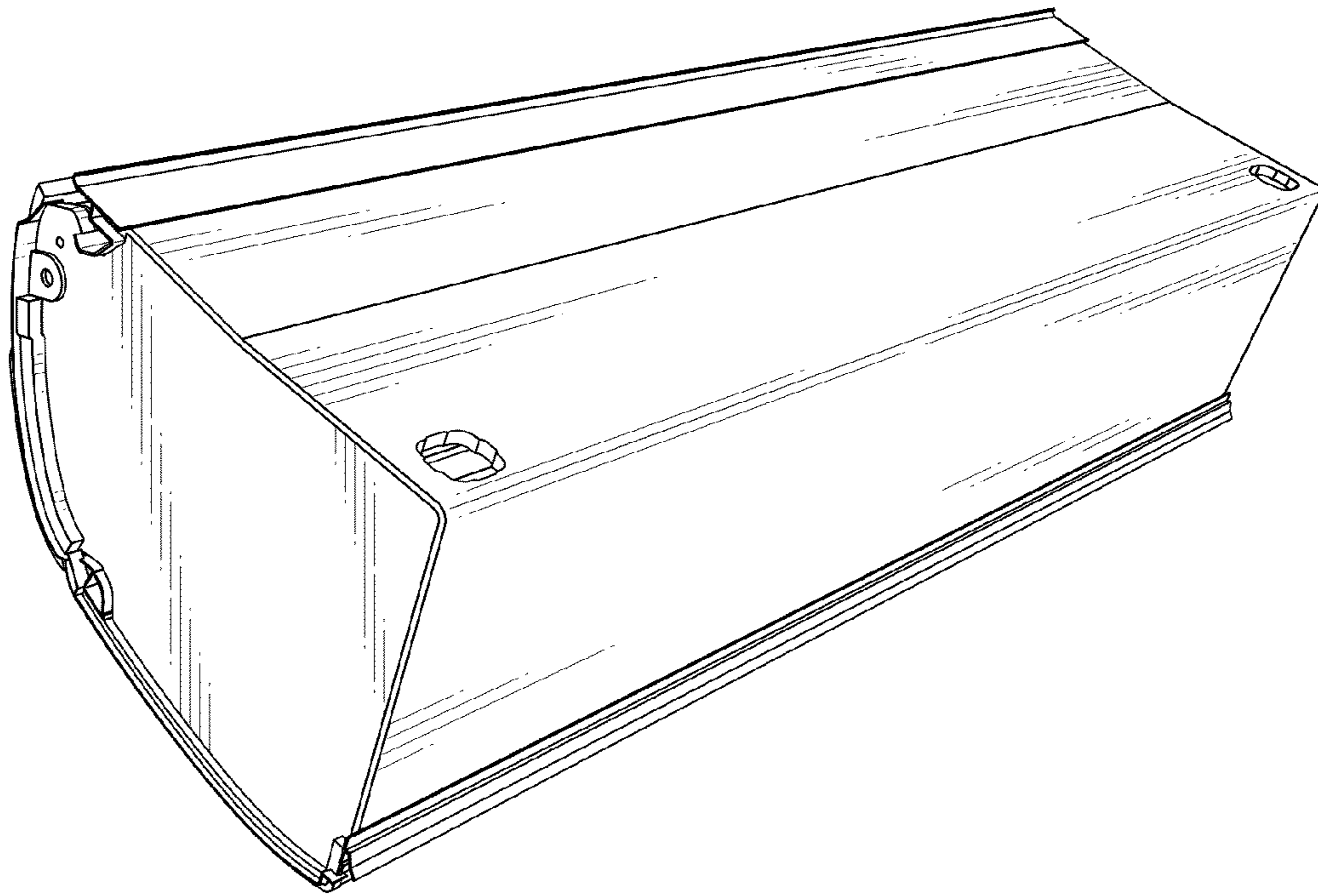

FIG. 3

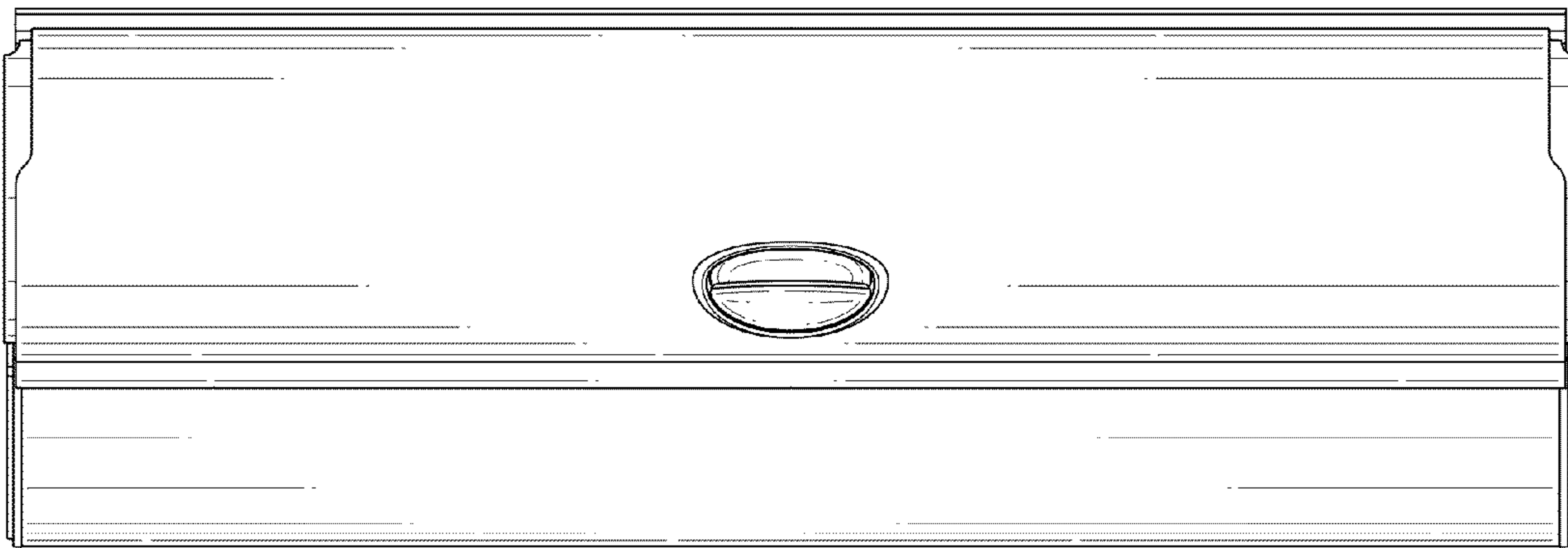

FIG. 4

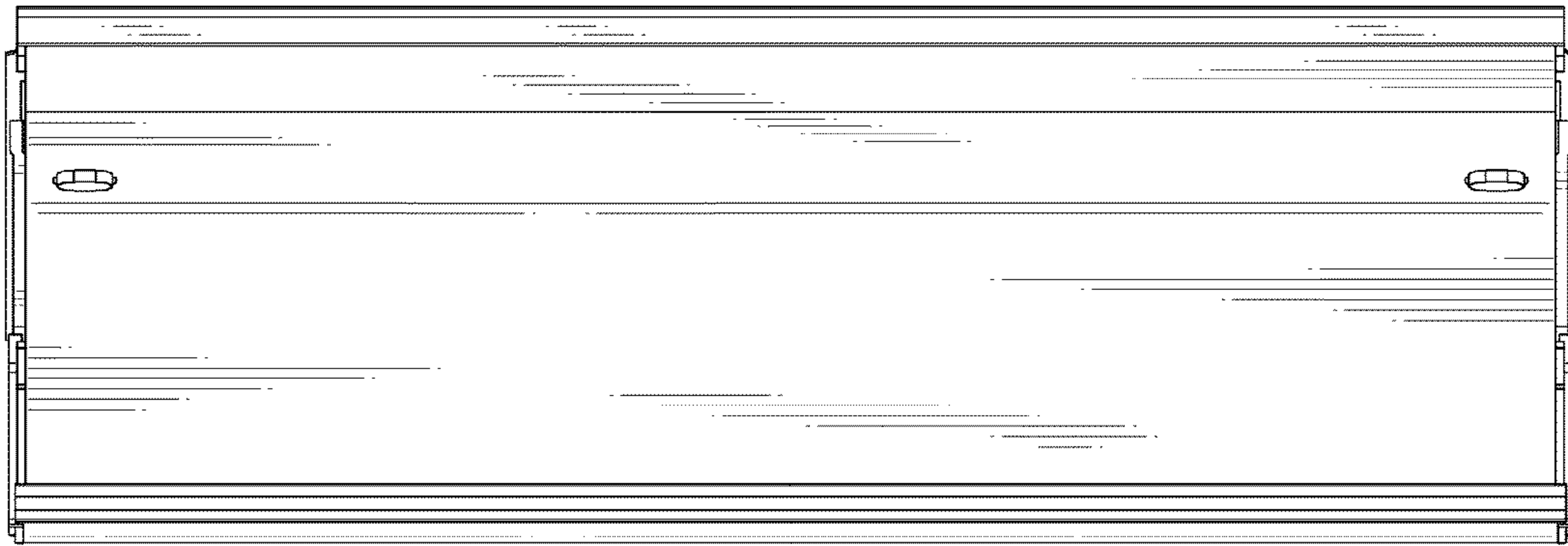

FIG. 5

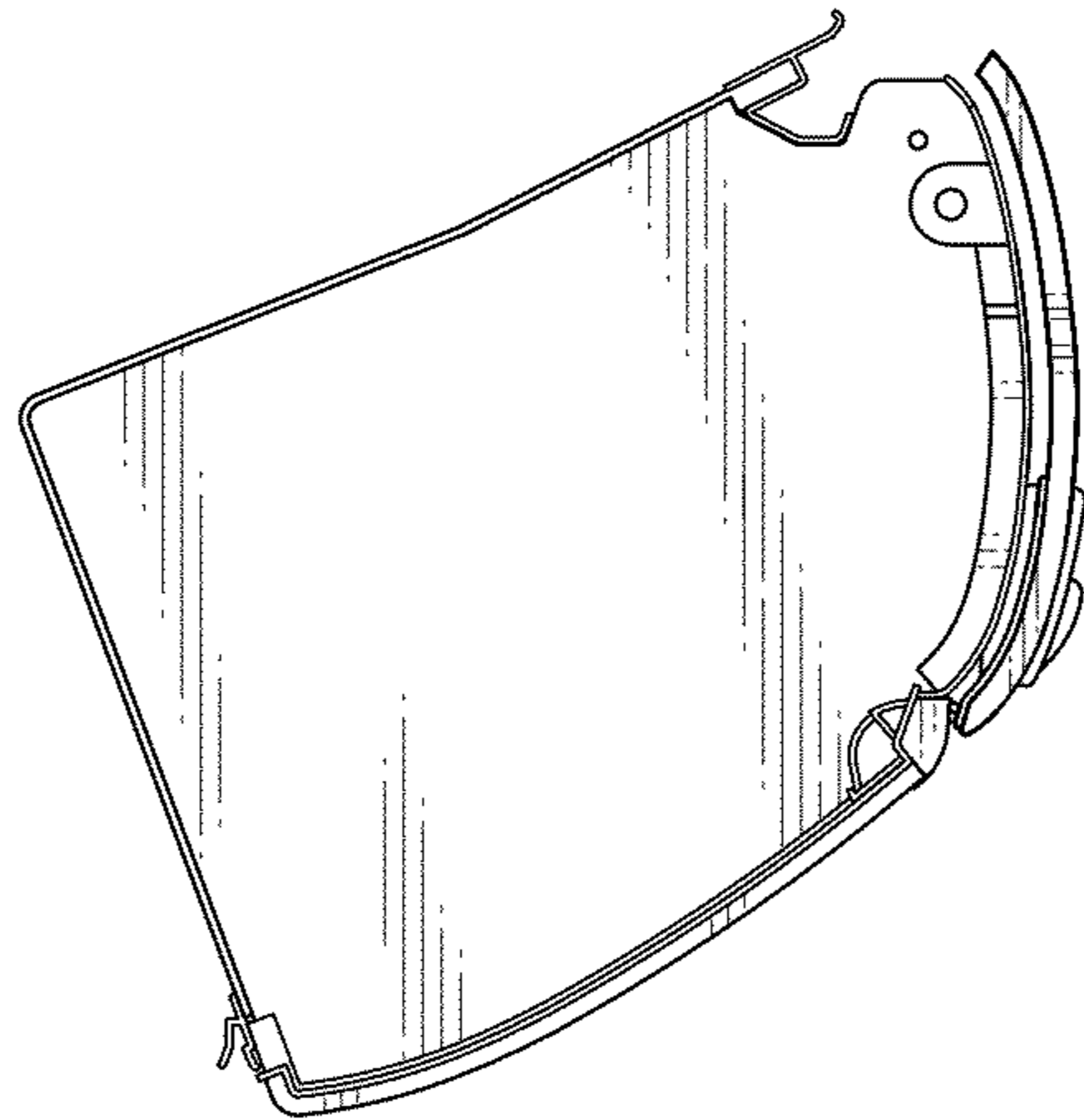

FIG. 6

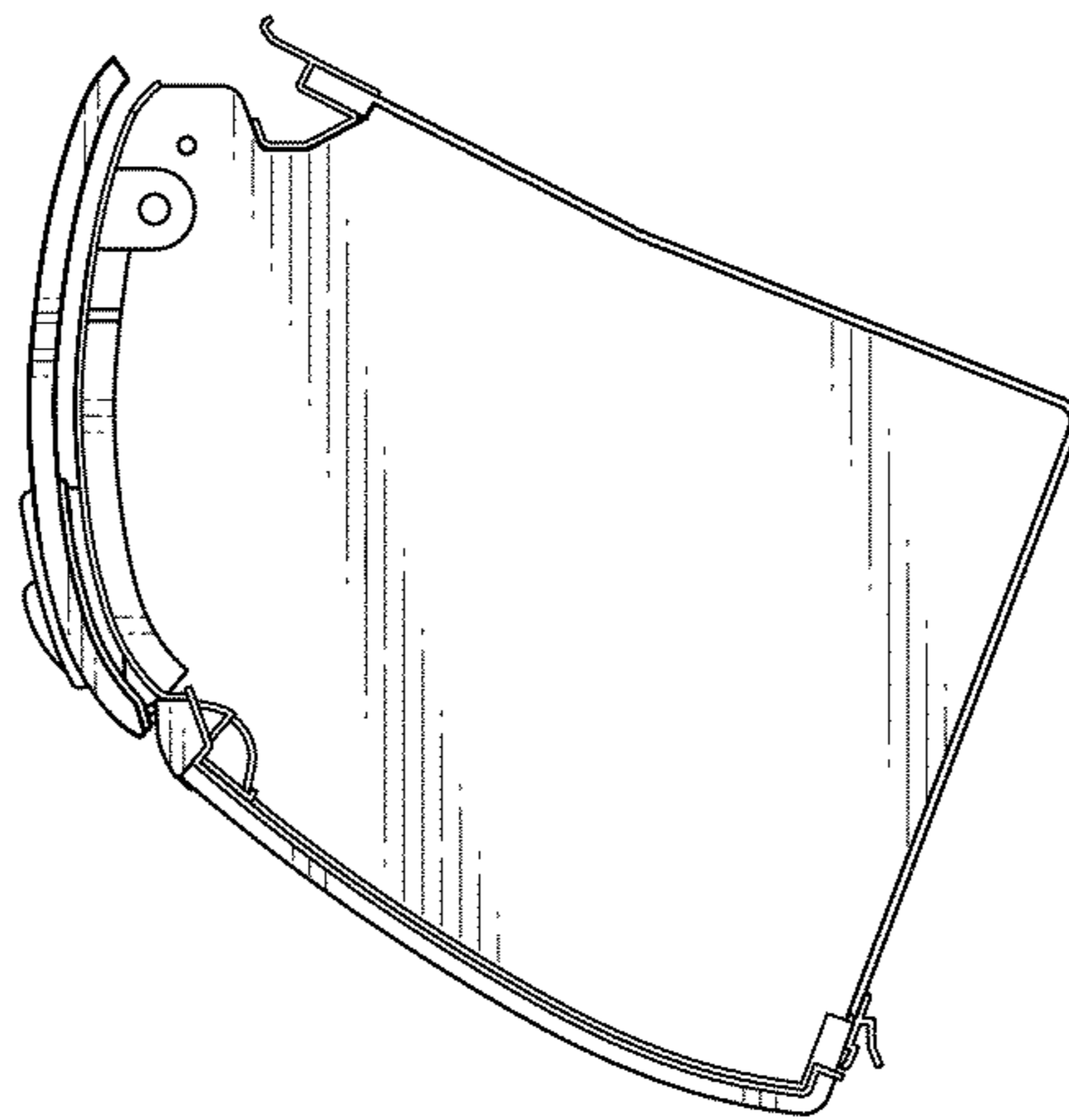

FIG. 7

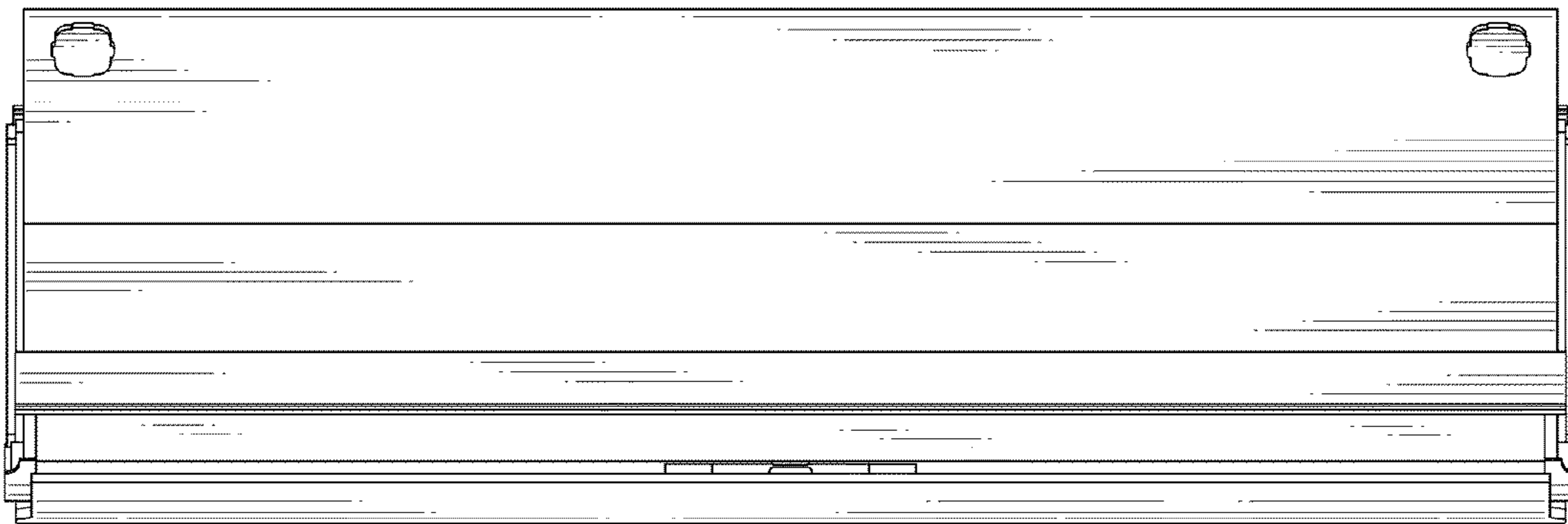



FIG. 8



FIG. 9

