



US00D680933S

(12) **United States Design Patent**  
**Hale, Jr.**

(10) **Patent No.:** **US D680,933 S**  
(45) **Date of Patent:** **\*\* Apr. 30, 2013**

(54) **SPOKE SEGMENT OF A VEHICLE WHEEL**

(71) Applicant: **Mobile Hi-Tech Wheels**, Rancho Dominguez, CA (US)

(72) Inventor: **Arthur D. Hale, Jr.**, Long Beach, CA (US)

(73) Assignee: **Mobile Hi-Tech Wheels**, Rancho Dominguez, CA (US)

(\*\*) Term: **14 Years**

(21) Appl. No.: **29/435,828**

(22) Filed: **Oct. 29, 2012**

(51) **LOC (9) Cl.** ..... **12-16**

(52) **U.S. Cl.**  
USPC ..... **D12/209; D12/213**

(58) **Field of Classification Search** ..... D12/204-213;  
301/37.101, 64.101, 65, 64.201  
See application file for complete search history.

(56) **References Cited**

**U.S. PATENT DOCUMENTS**

D579,845 S *	11/2008	Chung	.....	D12/209
D582,829 S *	12/2008	Musser	.....	D12/211
D590,315 S *	4/2009	Chung	.....	D12/209
D620,863 S *	8/2010	Groom	.....	D12/209

D625,242 S *	10/2010	Zhao	.....	D12/211
D629,347 S *	12/2010	Kim	.....	D12/211
D633,028 S *	2/2011	Kim	.....	D12/211
D639,222 S *	6/2011	Johnson	.....	D12/209
D639,223 S *	6/2011	Johnson	.....	D12/209
D644,156 S *	8/2011	Johnson	.....	D12/209
D649,101 S *	11/2011	Hale, Jr.	.....	D12/209
D659,067 S *	5/2012	Lee	.....	D12/209
D664,907 S *	8/2012	Hale, Jr.	.....	D12/209
D669,009 S *	10/2012	Chung	.....	D12/211

\* cited by examiner

*Primary Examiner* — Stacia Cadmus

(74) *Attorney, Agent, or Firm* — Christie, Parker & Hale, LLP

(57) **CLAIM**

The ornamental design for spoke segment of a vehicle wheel, as shown and described.

**DESCRIPTION**

FIG. 1 is a perspective view of a spoke segment of a vehicle wheel according to my new design; and, FIG. 2 is an enlarged front elevational view thereof.

The broken line showing of the rear of the wheel and the round elements on the lip of the rim is included for the purpose of illustrating environment and forms no part of the claimed design. The dash dot line on either side of the spoke segment is for the purpose of illustrating the boundary of the claimed design and forms no part thereof.

**1 Claim, 2 Drawing Sheets**

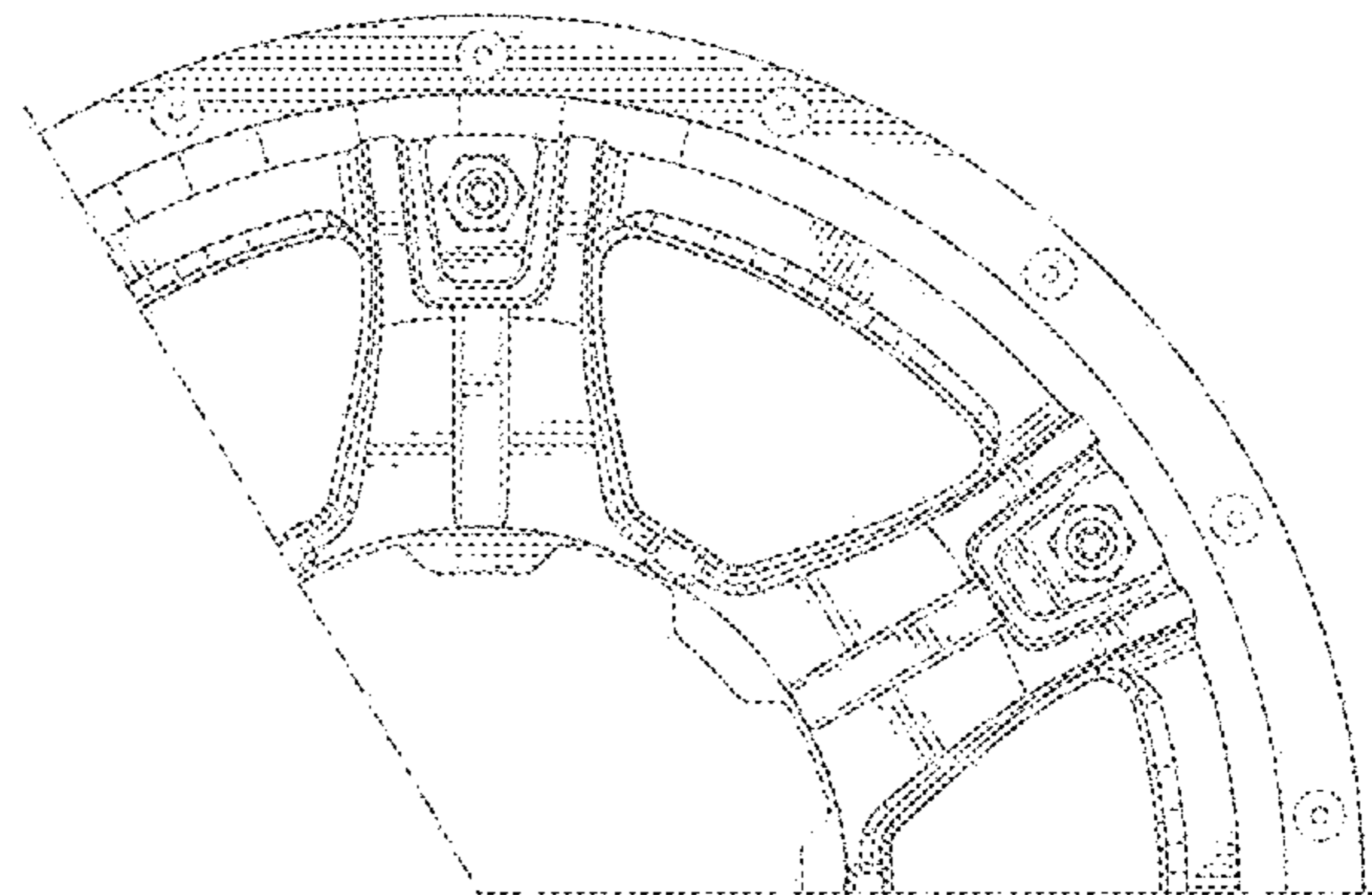
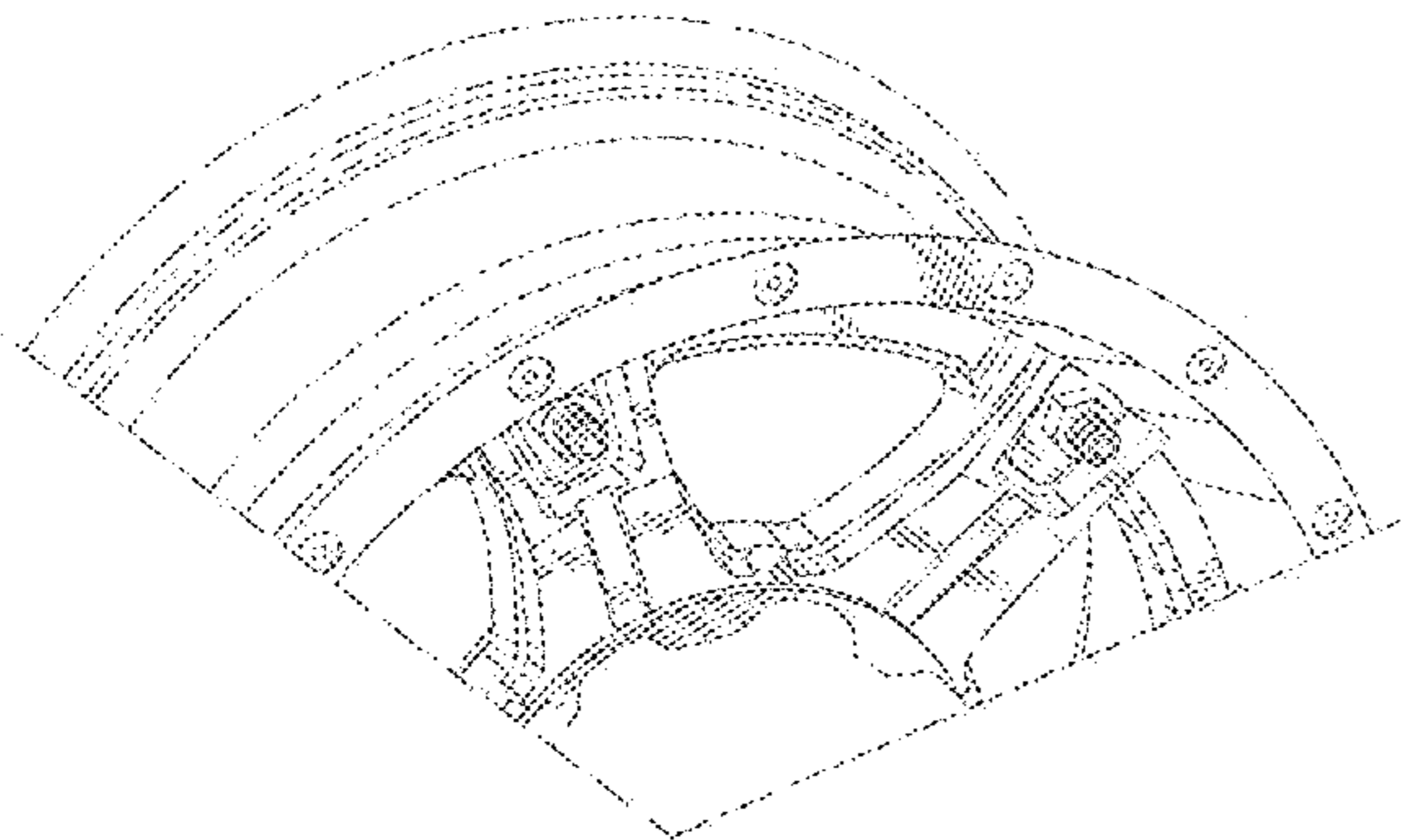

FIG. 1

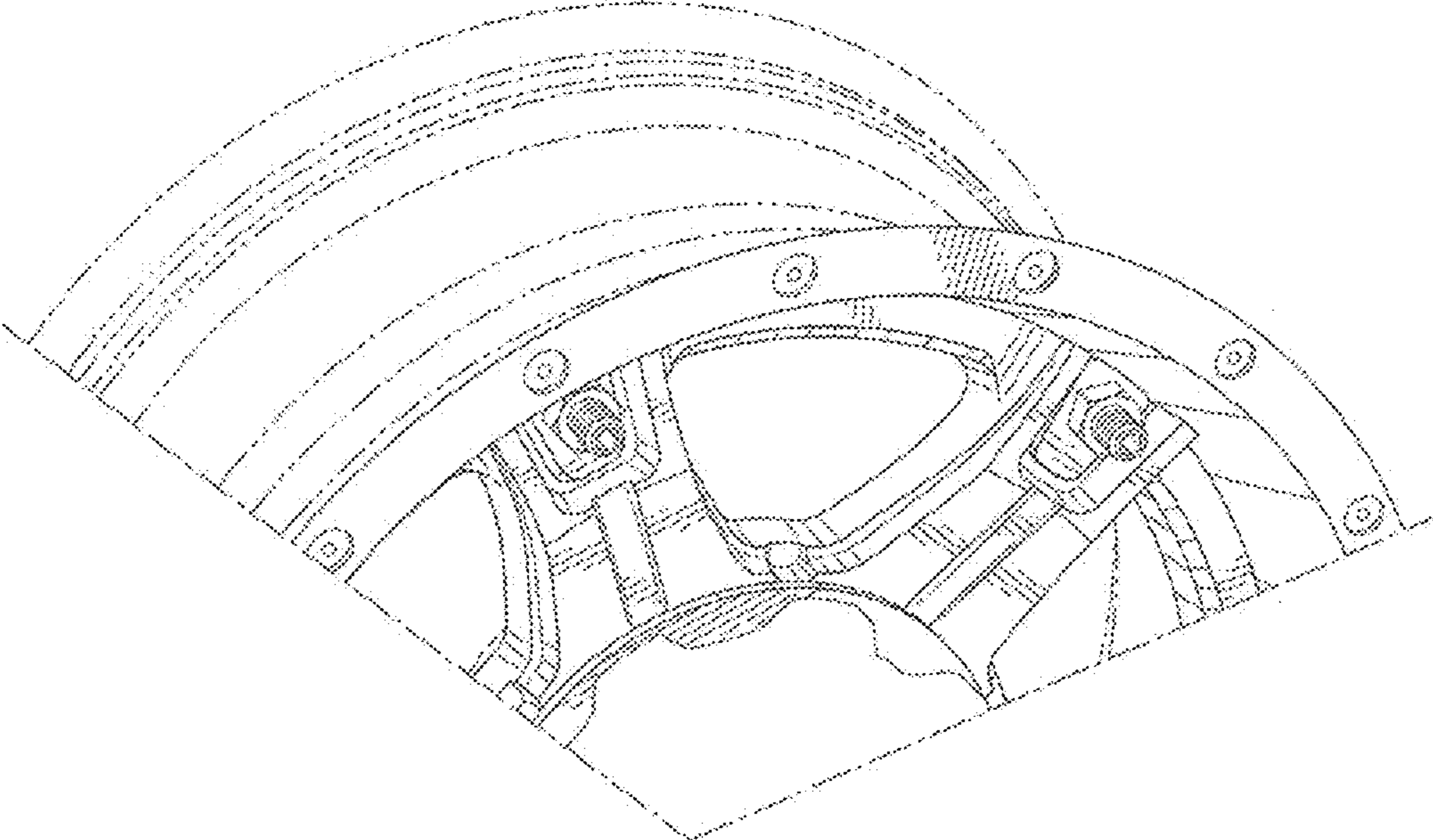

FIG. 2

