



US00D680929S

(12) **United States Design Patent**  
**Hanson et al.**

(10) **Patent No.:** **US D680,929 S**  
(45) **Date of Patent:** **\*\* Apr. 30, 2013**

- (54) **MUDFLAP OF A TRUCK**
- (75) Inventors: **Eric J. Hanson**, Valparaiso, IN (US);  
**Robert B. Riggs**, Canton, MI (US)
- (73) Assignee: **Caterpillar Inc.**, Peoria, IL (US)
- (\*\*) Term: **14 Years**
- (21) Appl. No.: **29/413,736**
- (22) Filed: **Feb. 20, 2012**

D458,875 S 6/2002 Maher et al.  
D460,023 S 7/2002 Beigel  
D460,393 S 7/2002 Kidd

(Continued)

**OTHER PUBLICATIONS**

Photograph of Jeep Aftermarket Fender Flare, [http://www.innerauto.com/Jeep\\_Fender\\_Flare/](http://www.innerauto.com/Jeep_Fender_Flare/), Accessed May 11, 2010 prior to Application Filing Date.

(Continued)

*Primary Examiner* — Melody N Brown

(74) *Attorney, Agent, or Firm* — Finnegan, Henderson, Farabow, Garrett & Dunner LLP

**Related U.S. Application Data**

- (62) Division of application No. 29/381,459, filed on Dec. 20, 2010, now Pat. No. Des. 660,207.
- (51) **LOC (9) Cl.** ..... **12-16**
- (52) **U.S. Cl.**  
USPC ..... **D12/185**
- (58) **Field of Classification Search** ..... D12/184,  
D12/196, 90-92, 181, 202, 185, 96, 93; 280/152.1,  
280/847-851; 296/181.1, 181.5; 224/42.24,  
224/42.26, 42.12; 180/180.1, 180.2; 416/86-88  
See application file for complete search history.

(57) **CLAIM**

The ornamental design for a mudflap of a truck, as shown and described.

**DESCRIPTION**

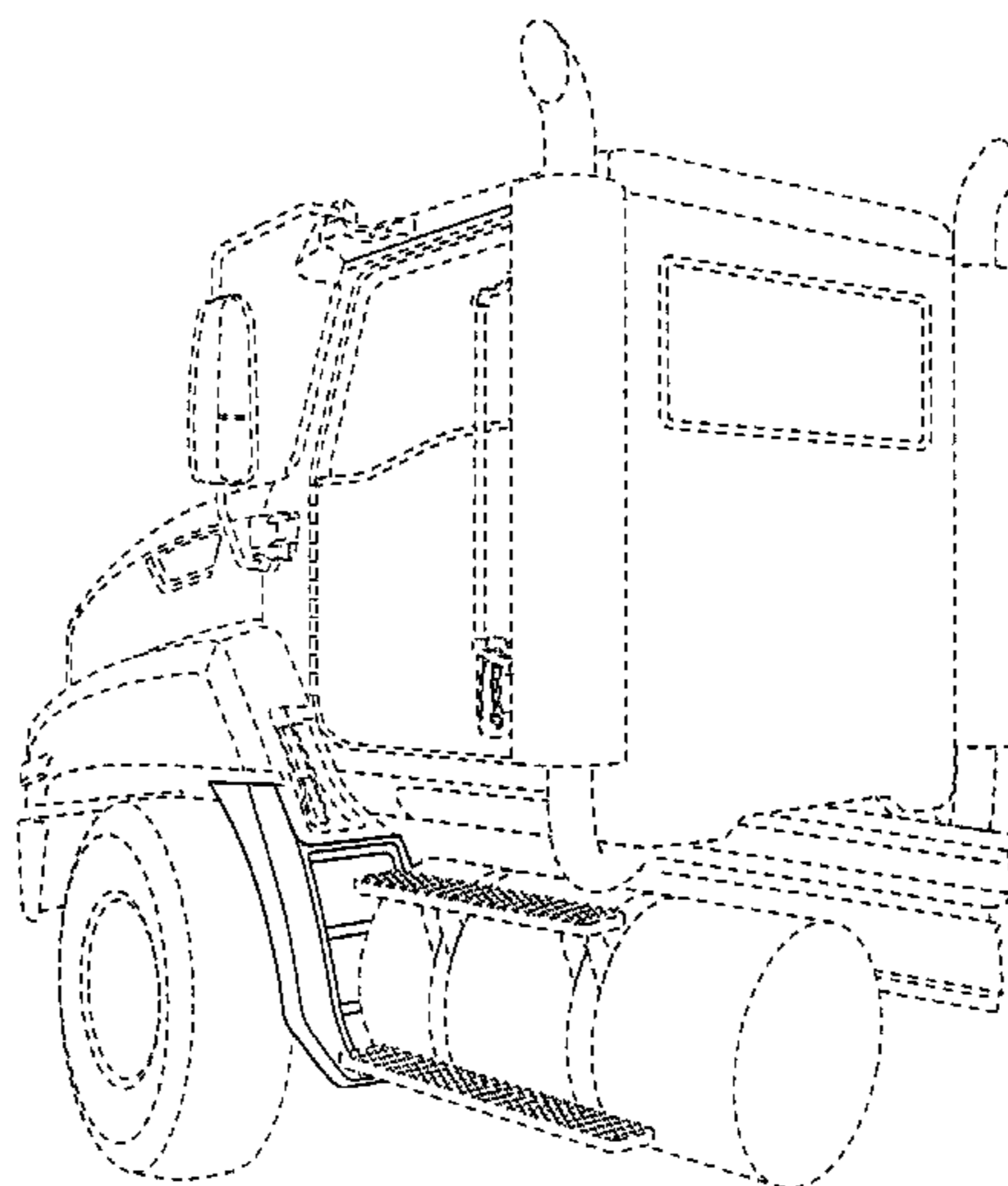
FIG. 1 is a right, rear perspective view of a mudflap of a truck showing our new design, the portions of the truck shown in broken lines are for illustrative purposes only and form no part of the claimed design;  
FIG. 2 is an enlarged right, front perspective view thereof, without the truck portions shown;  
FIG. 3 is an enlarged right side elevational view thereof;  
FIG. 4 is an enlarged left side elevational view thereof;  
FIG. 5 is an enlarged top plan view thereof;  
FIG. 6 is an enlarged front elevational view thereof;  
FIG. 7 is an enlarged rear elevational view thereof; and,  
FIG. 8 is an enlarged bottom plan view thereof.  
The broken lines of the figures showing additional portions of the truck are included for the purpose of illustrating environmental structure and form no part of the claimed design. The claimed design includes a mirror image of the embodiment depicted.

(56) **References Cited**

**U.S. PATENT DOCUMENTS**

D335,272 S	5/1993	Allendorph et al.	
D366,640 S	1/1996	Tucker et al.	
D367,027 S	2/1996	Onopa	
D387,317 S	12/1997	Lang	
D394,026 S	5/1998	Hellhake et al.	
D397,072 S	8/1998	Hellhake et al.	
D406,087 S *	2/1999	Bavington et al. ....	D12/185
D407,360 S	3/1999	Hellhake et al.	
D416,221 S	11/1999	Sutton et al.	
D421,412 S	3/2000	Sutton et al.	
D437,574 S	2/2001	Beigel	
6,286,968 B1	9/2001	Sailer et al.	
D452,671 S	1/2002	Lang	
D453,490 S *	2/2002	Conway .....	D12/185
D455,688 S *	4/2002	Conway .....	D12/185

**1 Claim, 8 Drawing Sheets**



U.S. PATENT DOCUMENTS

D466,455	S	12/2002	Kidd et al.	
D479,490	S *	9/2003	Cadotte et al. ....	D12/7
D482,993	S	12/2003	Conway et al.	
6,764,207	B2	7/2004	Abalos et al.	
D498,193	S	11/2004	Metros et al.	
D545,255	S	6/2007	Angelo et al.	
7,232,234	B2	6/2007	Branham et al.	
D552,515	S	10/2007	Prosser et al.	
7,318,650	B2	1/2008	Courbon	
D581,333	S	11/2008	Enz	
D593,396	S	6/2009	Habib	
D612,309	S	3/2010	Beigel et al.	
D615,472	S *	5/2010	Maher et al. ....	D12/196
D621,756	S *	8/2010	Angelo et al. ....	D12/184
D652,774	S *	1/2012	Aris et al. ....	D12/196
2009/0161378	A1	6/2009	Enz	

OTHER PUBLICATIONS

Photograph of Honda Ridgeline Custom Fender Conversion, <http://www.ridgelineownersclub.com/forums/showthread.php?t=28525> &page=20, Accessed May 11, 2010 prior to Application Filing Date.

Photograph of Dodge Ram Aftermarket Fender Flare (Bolt Access From the Front), [http://www.truckaccessories.ca/store/index.php?main\\_page=index&cPath=34](http://www.truckaccessories.ca/store/index.php?main_page=index&cPath=34), Accessed May 11, 2010 prior to Application Filing Date.

Photograph of Honda Ridgeline—OEM Concept Package, <http://www.ultimatecarpage.com/car/2535/Honda-Ridgeline-All-Terrain-Concept.html>, Accessed May 11, 2010 prior to Application Filing Date.

Photograph of Stampede Truck Accessories: Aftermarket Fender Flare for GMC/Chevy Truck, <http://www.4wheelonline.com/jeep/StampedeFenderFlares.54162>, Accessed May 11, 2010 prior to Application Filing Date.

Photograph of Polaris ATV Fender Flare: Aftermarket Accessory, <http://www.crawltech.com/side-x-side-parts-5/polaris-rzr-parts-7/rzr-body-parts-93/polaris-rzr-fender-flares-286.html>, Accessed May 11, 2010 prior to Application Filing Date.

Photograph of Jeep Custom Pack (by AEV) with New Flares, <http://www.jeepcommander.com/forums/showthread.php?t=11440>, Accessed May 11, 2010 prior to Application Filing Date.

Photograph of Kenworth T800 Cab, <http://www.kenworth.com/brochures/T800.pdf>, Accessed May 11, 2010 prior to Application Filing Date.

Photograph of Ford F150 Door (on Raptor Model), <http://www.fordvehicles.com/trucks/f150/gallery/photos/>, Accessed May 11, 2010 prior to Application Filing Date.

Photograph of 2011 Ford Super Duty, <http://www.fordvehicles.com/trucks/superduty/gallery/photos/>, Accessed May 11, 2010 prior to Application Filing Date.

Photograph of Mack Pinnacle, [http://www.macktrucks.com/assets/MackMarketing/Brochures/BulDgLnBro/4601\\_BulDgLnBro.pdf](http://www.macktrucks.com/assets/MackMarketing/Brochures/BulDgLnBro/4601_BulDgLnBro.pdf), Accessed May 12, 2010 prior to Application Filing Date.

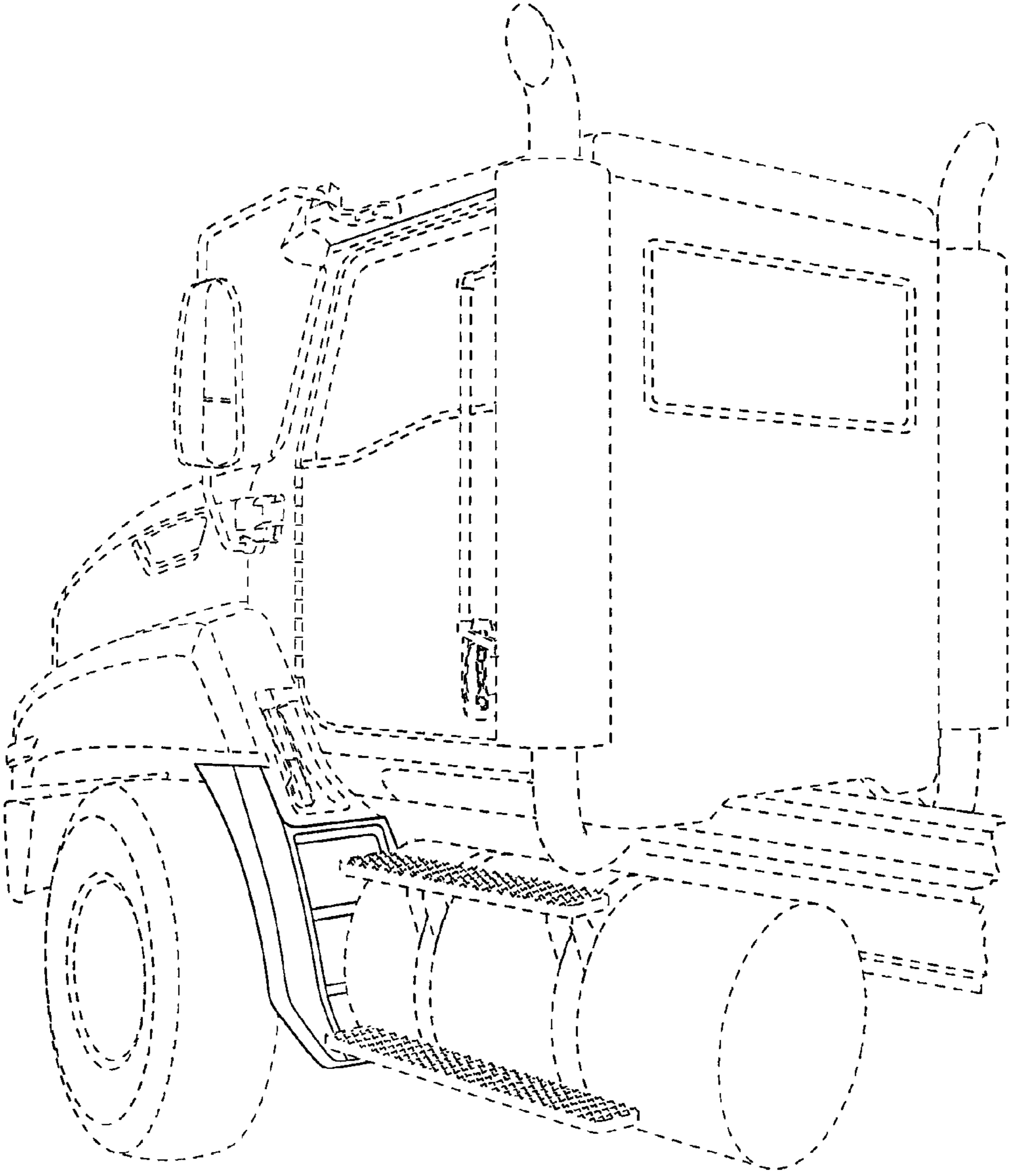
Photograph of International 9200i, [http://www.internationaltrucks.com/InternationalTrucks/V2Global/Brochures/9200i\\_brochure.pdf](http://www.internationaltrucks.com/InternationalTrucks/V2Global/Brochures/9200i_brochure.pdf), Accessed May 12, 2010 prior to Application Filing Date.

Photograph of Velvac 708331 Side Mirror, <http://velvac.thomasnet.com/item/rors-mirror-systems-recreational-specialty-vehicle/7-x-16-heated-angle-back-mirror-with-marker-light/708331?&plpver=10&origin=keyword&by=prod&filter=0>, Accessed May 12, 2010 prior to Application Filing Date.

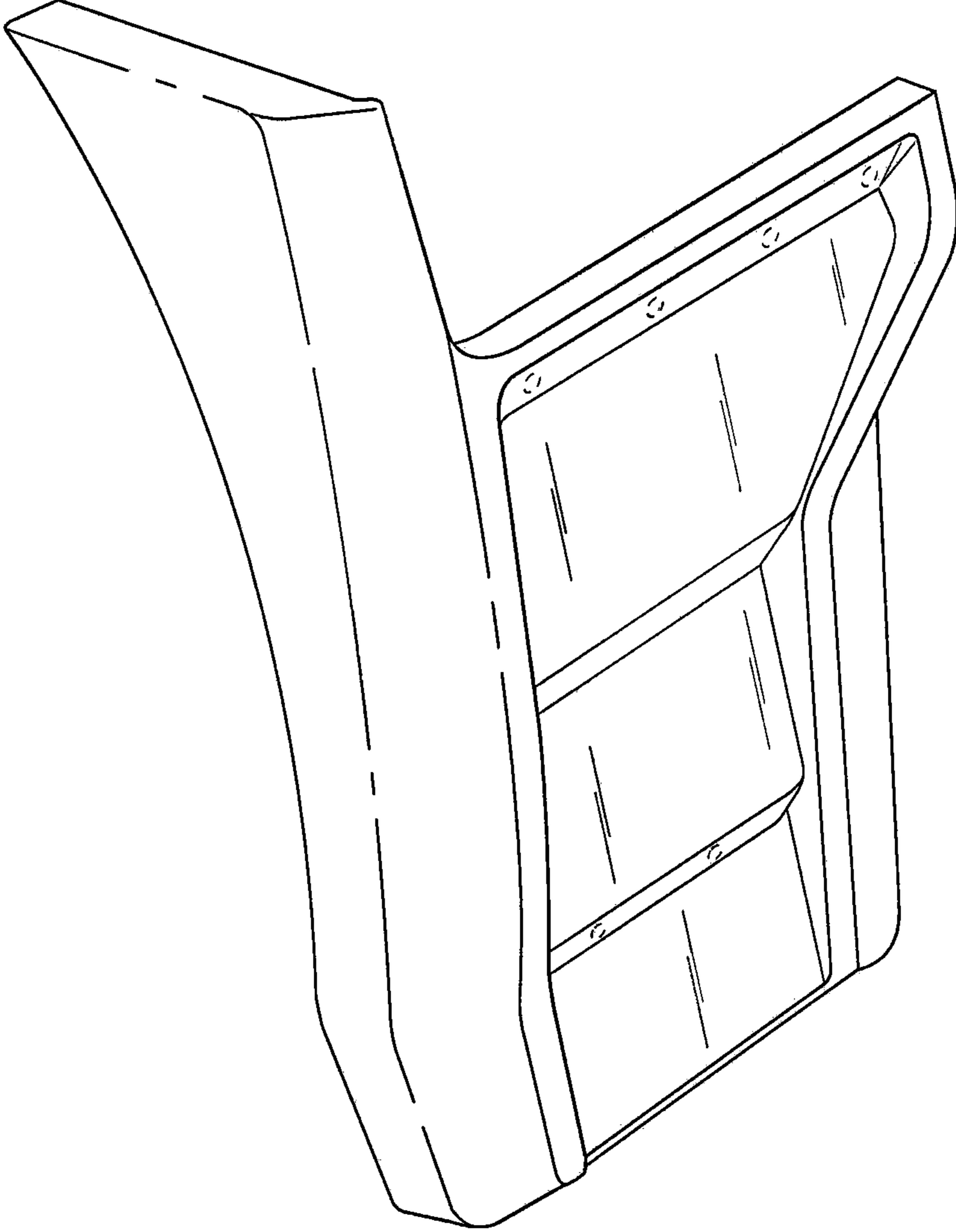
Photograph of Sure Plus Mirror, <http://www.sureplus.com/products/wetcoast.htm>, Accessed May 12, 2010 prior to Application Filing Date.

\* cited by examiner

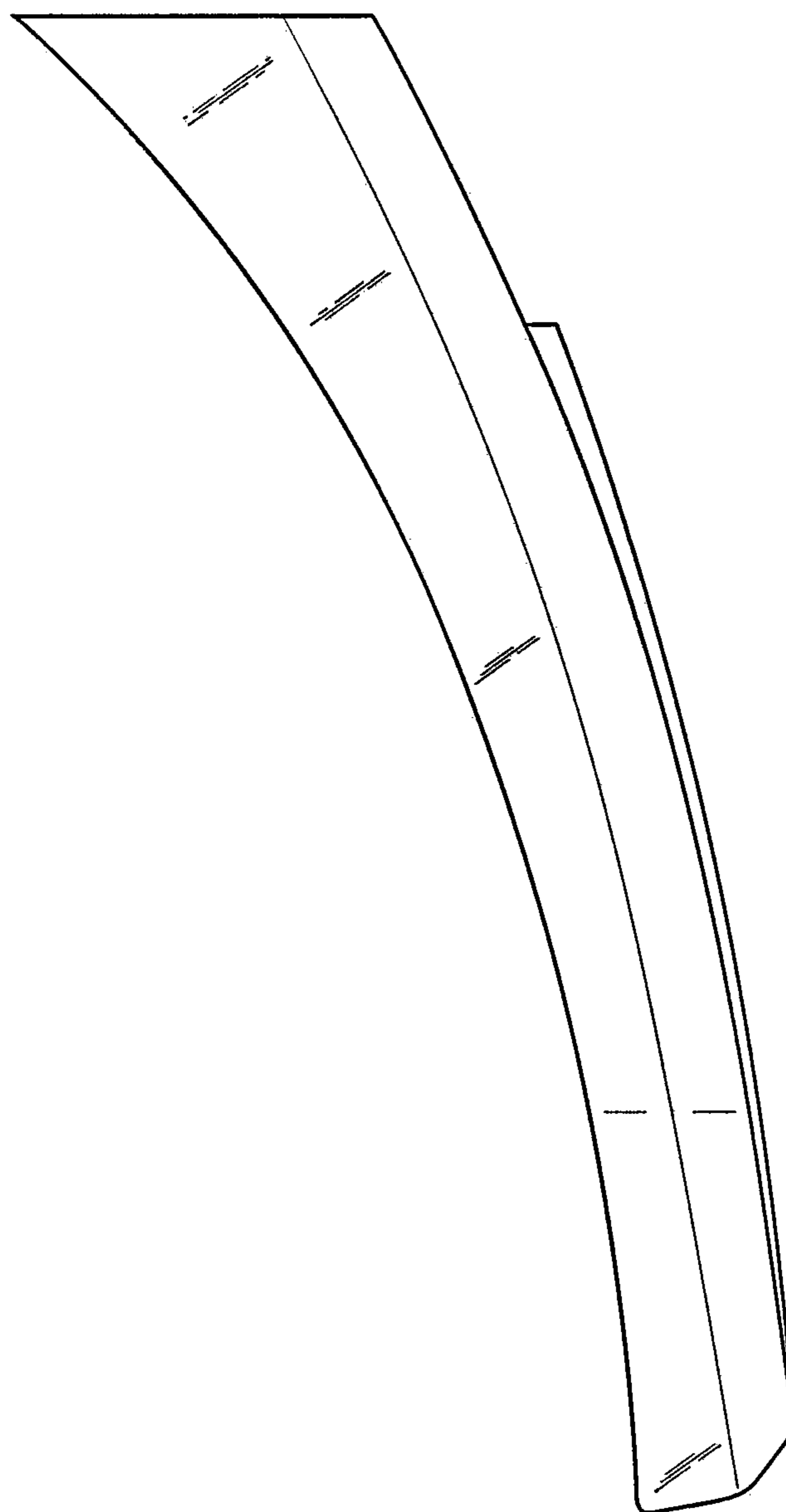
**FIG. 1**



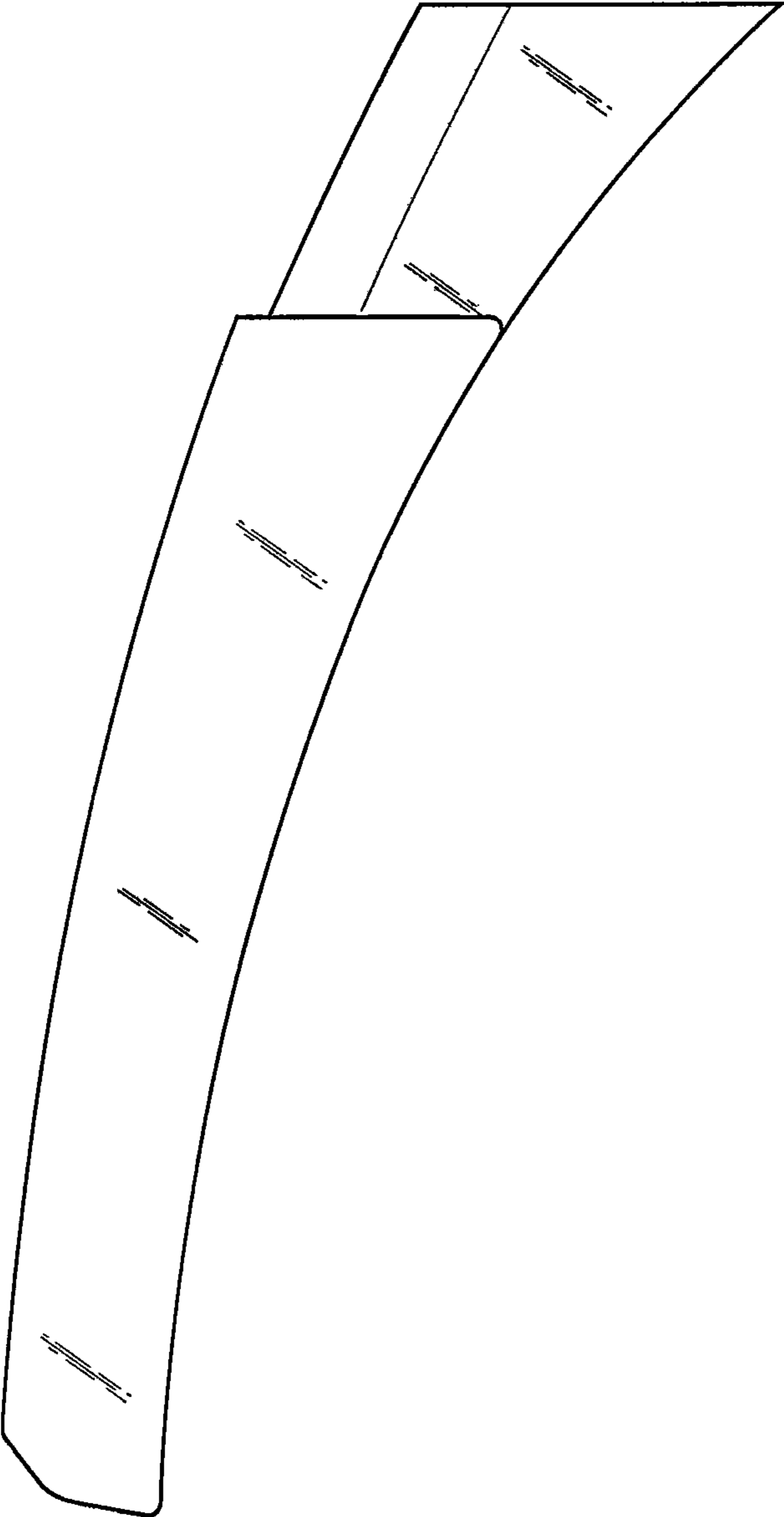
**FIG. 2**



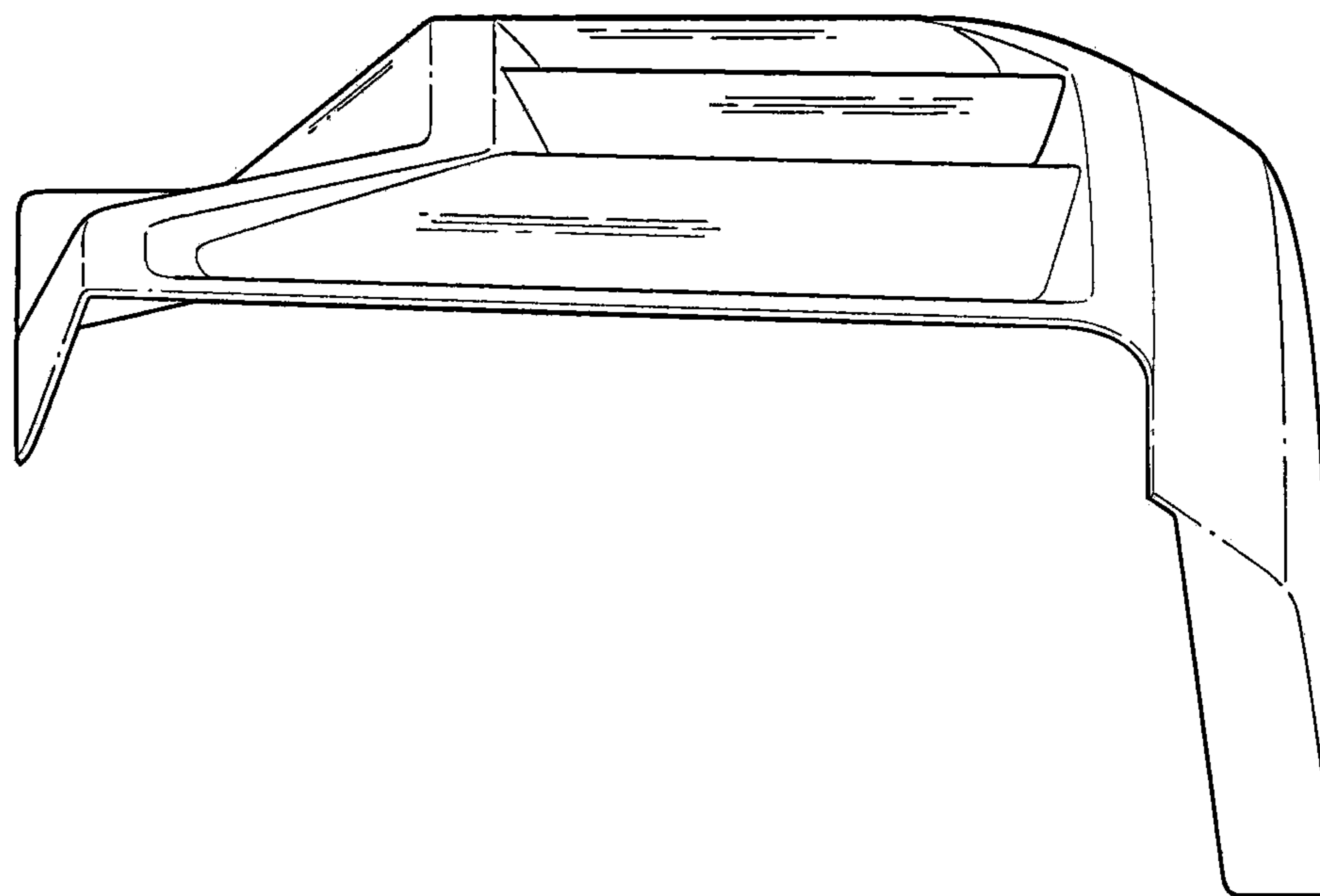
**FIG. 3**



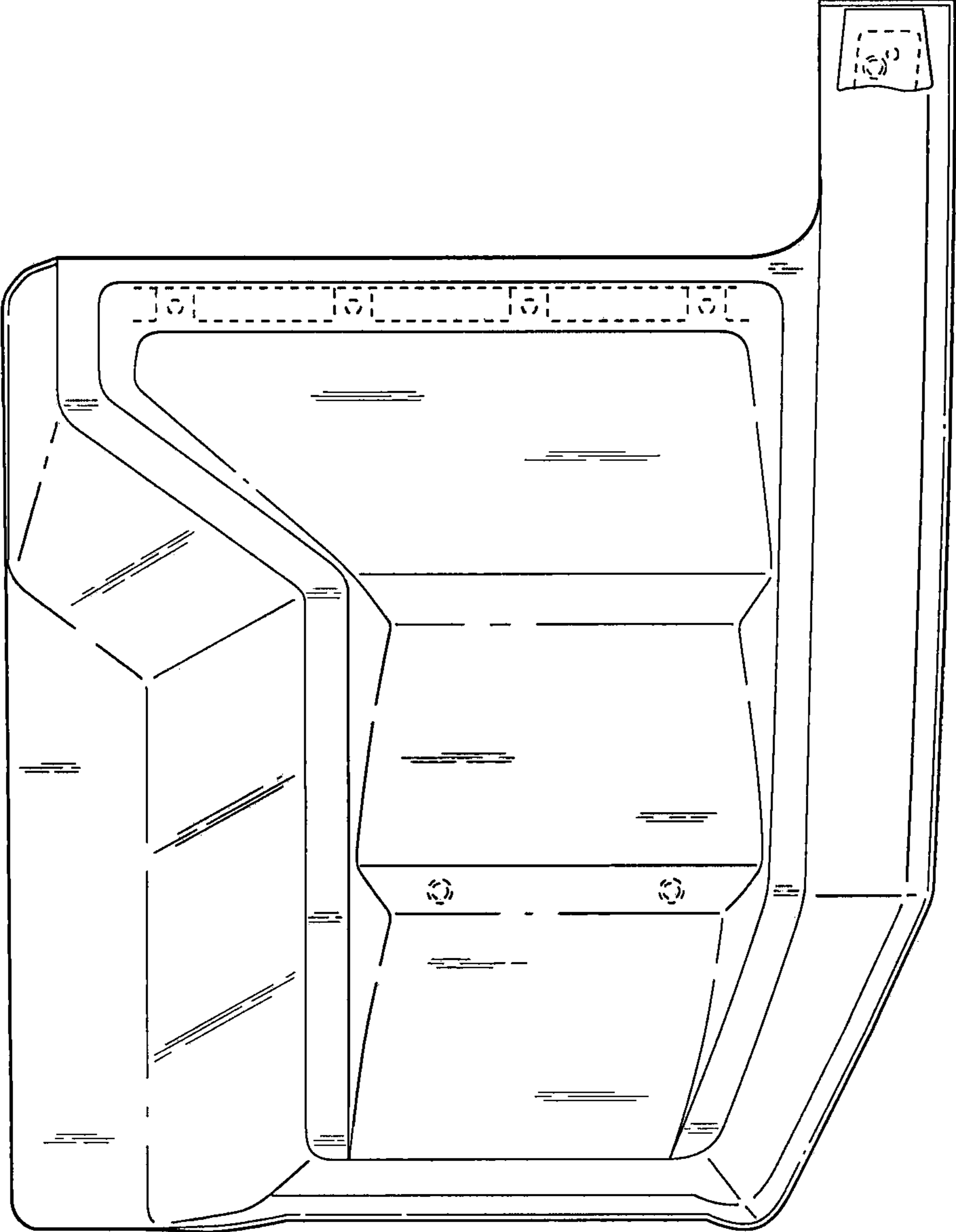
**FIG. 4**



**FIG. 5**

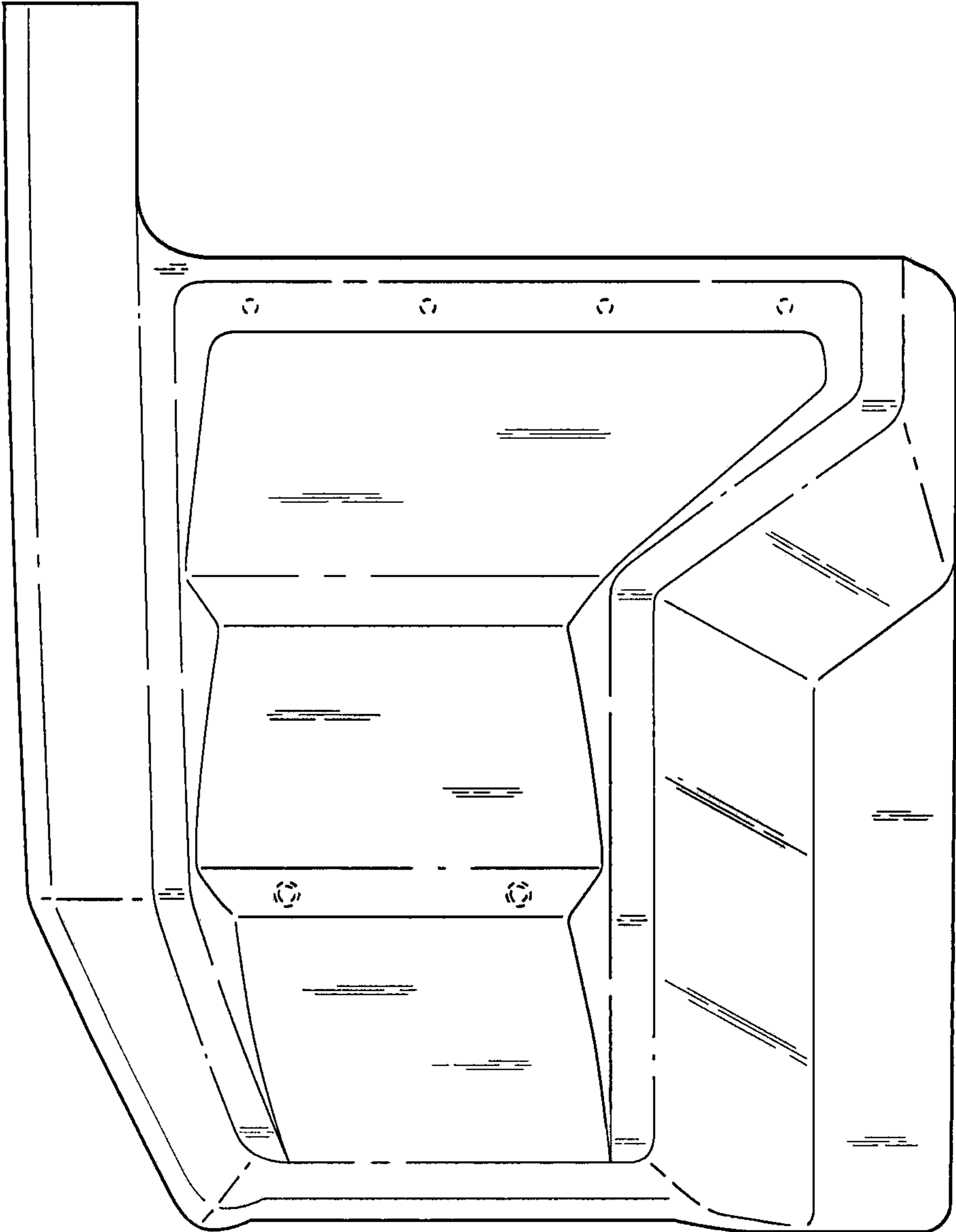


**FIG. 6**





**FIG. 7**



**FIG. 8**

