



US00D680904S

(12) **United States Design Patent**  
**Timan**

(10) **Patent No.:** **US D680,904 S**

(45) **Date of Patent:** **\*\* Apr. 30, 2013**

(54) **GANGWAY SECTION OF A RAILWAY  
VEHICLE**

5,761,757 A \* 6/1998 Mitchell et al. .... 14/71.5  
6,543,076 B1 \* 4/2003 Worpenberg et al. .... 14/71.5  
8,166,889 B2 \* 5/2012 Gomis ..... 105/8.1

(75) Inventor: **Peter Edward Timan**, Sydenham (CA)

\* cited by examiner

(73) Assignee: **Bombardier Transportation GmbH**,  
Berlin (DE)

*Primary Examiner* — T. Chase Nelson

*Assistant Examiner* — Ania Aman

(\*\*) Term: **14 Years**

(74) *Attorney, Agent, or Firm* — The Webb Law Firm

(21) Appl. No.: **29/422,837**

(22) Filed: **May 24, 2012**

(30) **Foreign Application Priority Data**

Nov. 25, 2011 (WO) ..... 638643901

(51) **LOC (9) Cl.** ..... **12-03**

(52) **U.S. Cl.**  
USPC ..... **D12/42**

(58) **Field of Classification Search** ..... D12/36-51;  
14/71.1; 105/10, 9, 4.2, 31, 145  
See application file for complete search history.

(56) **References Cited**

U.S. PATENT DOCUMENTS

4,858,535 A \* 8/1989 Bechu et al. .... 105/15  
5,033,395 A \* 7/1991 Bechu et al. .... 105/18

(57) **CLAIM**

The ornamental design for a gangway section of a railway vehicle, as shown and described.

**DESCRIPTION**

FIG. 1 is a left front perspective view of a gangway section of a railway vehicle showing my new design;  
FIG. 2 is a right front perspective view thereof;  
FIG. 3 is an upper left rear perspective view thereof;  
FIG. 4 is a top view thereof;  
FIG. 5 is a front view thereof; and,  
FIG. 6 is a rear view thereof.  
The broken line showings of FIGS. 1-6 are environmental only and not part of the claimed design.

**1 Claim, 6 Drawing Sheets**

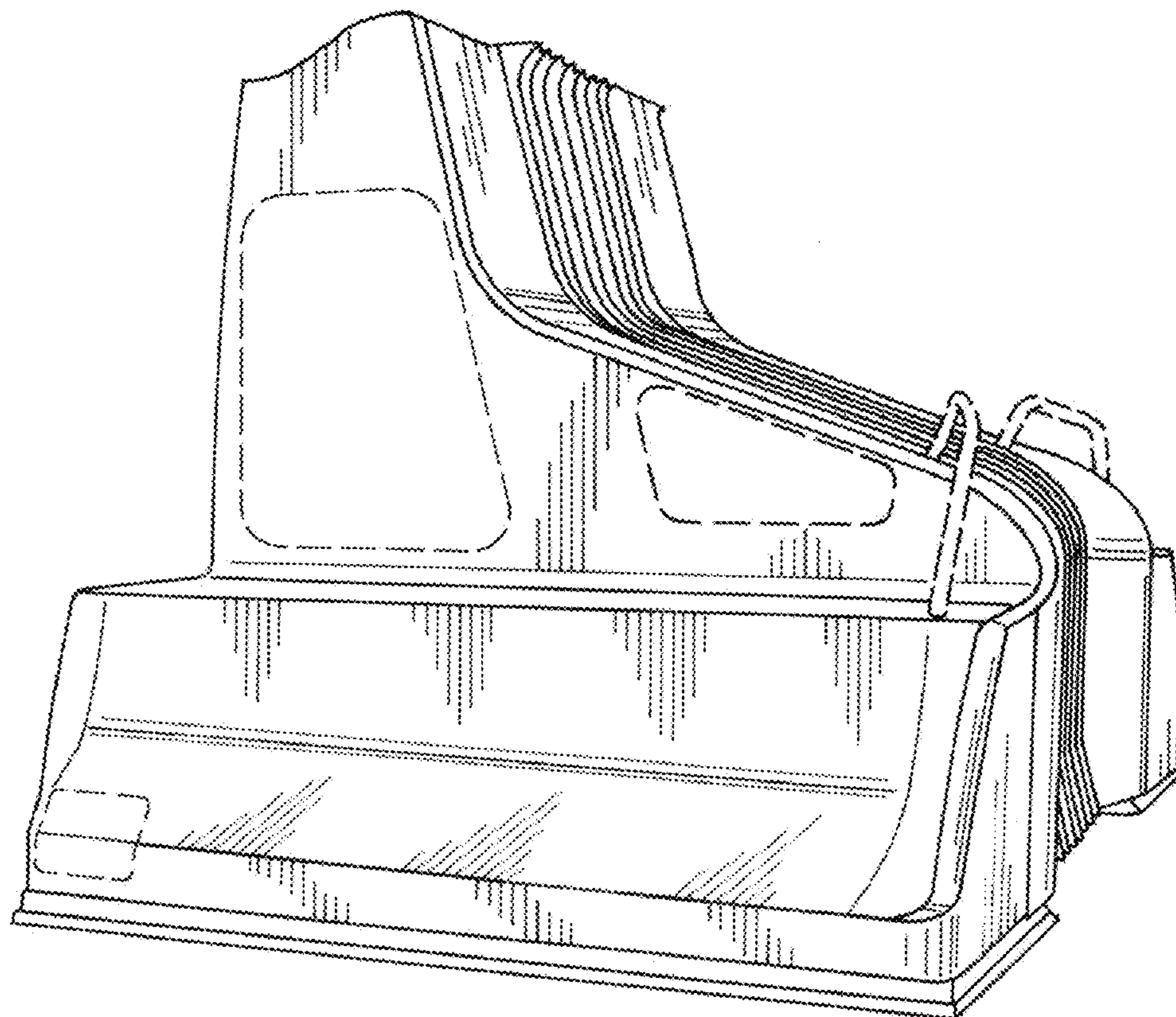

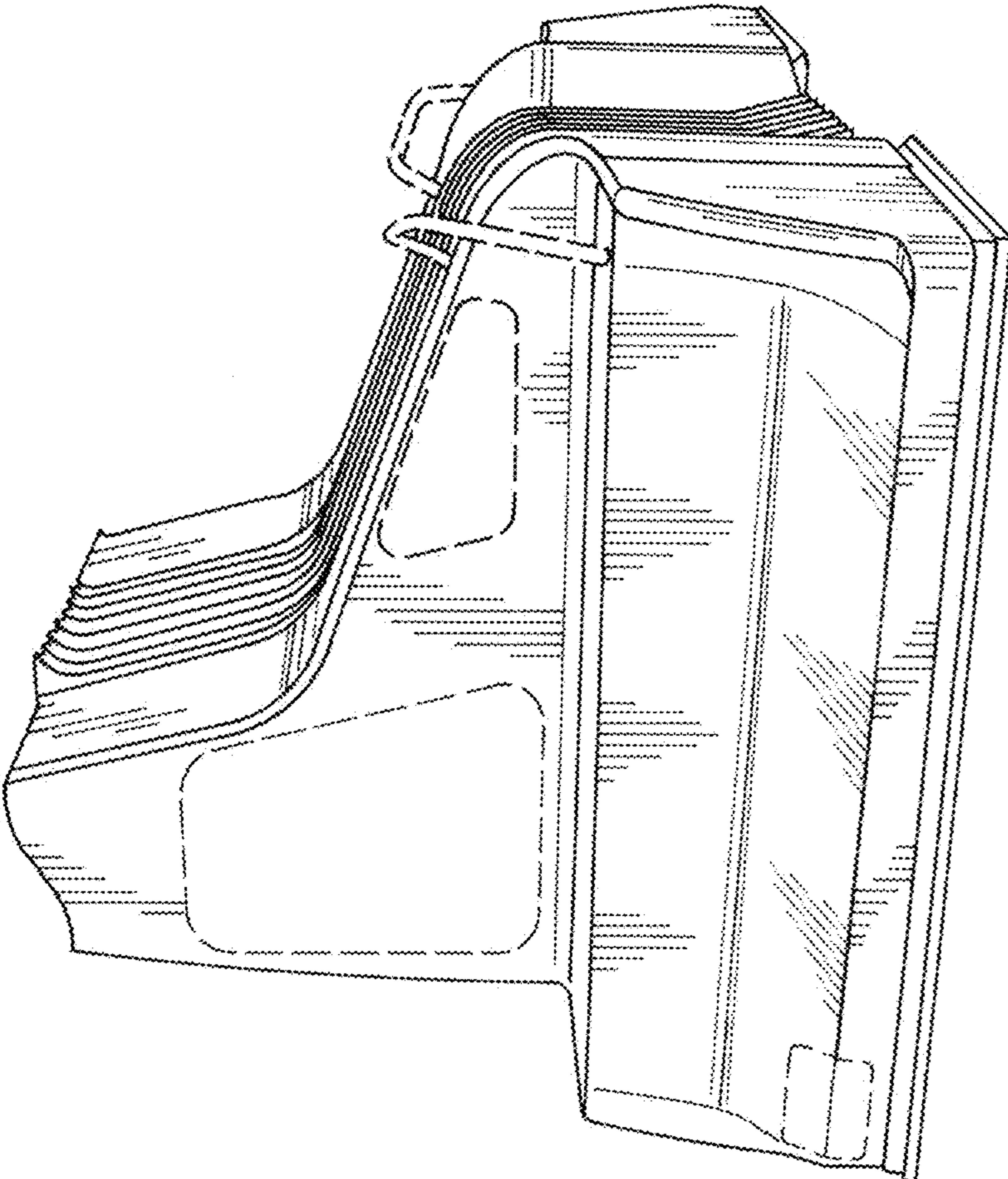

FIG. 1

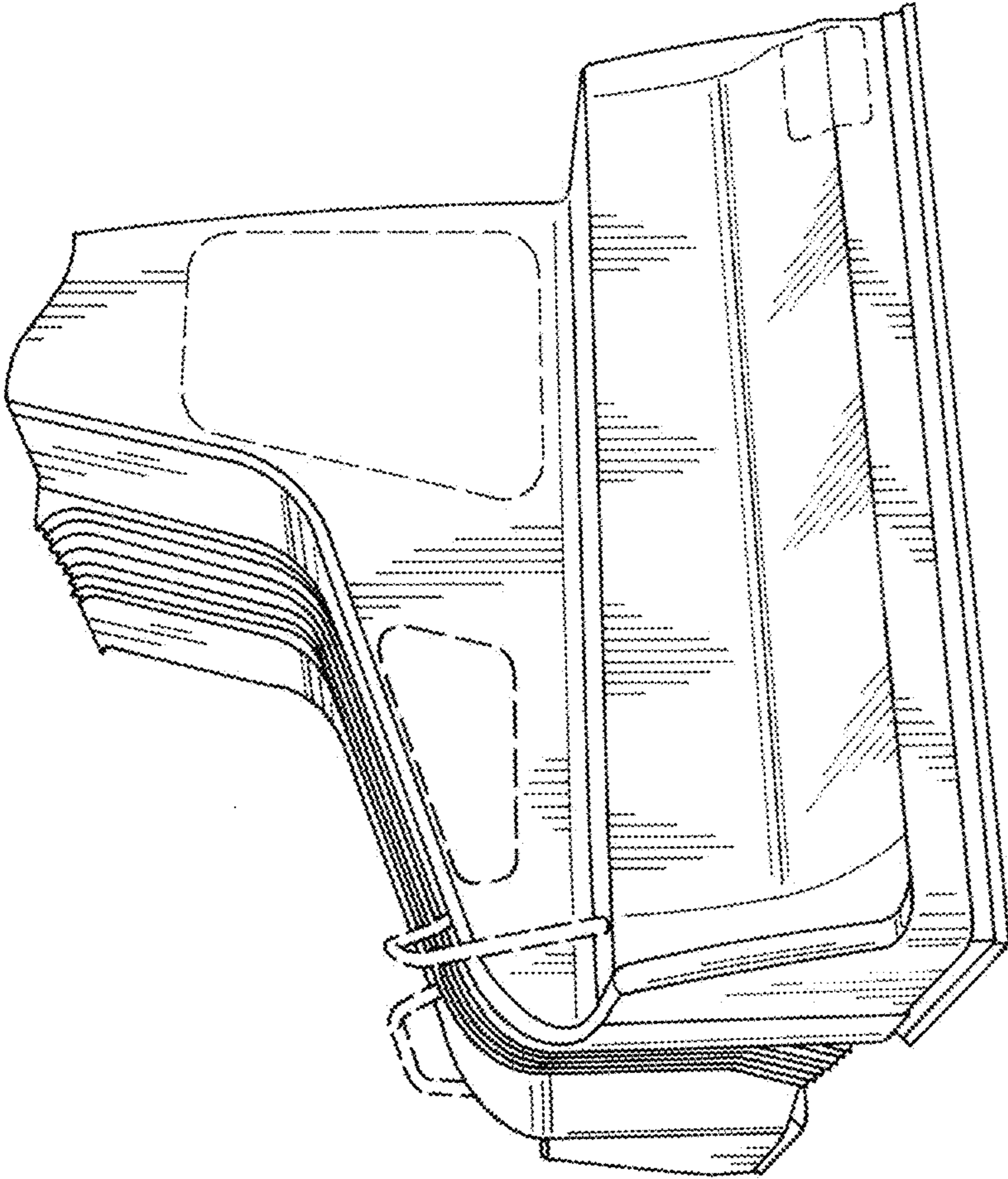

FIG. 2

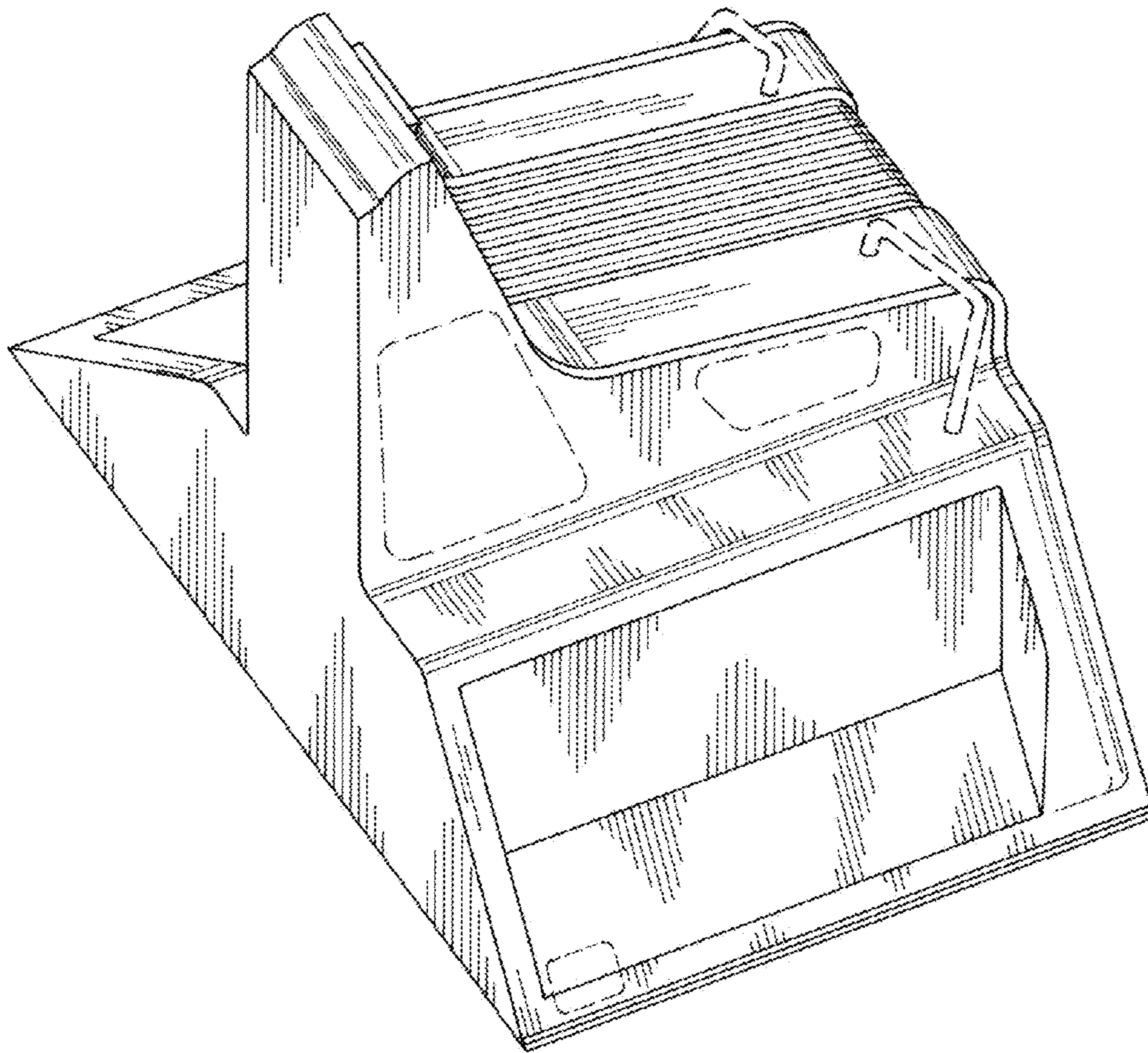
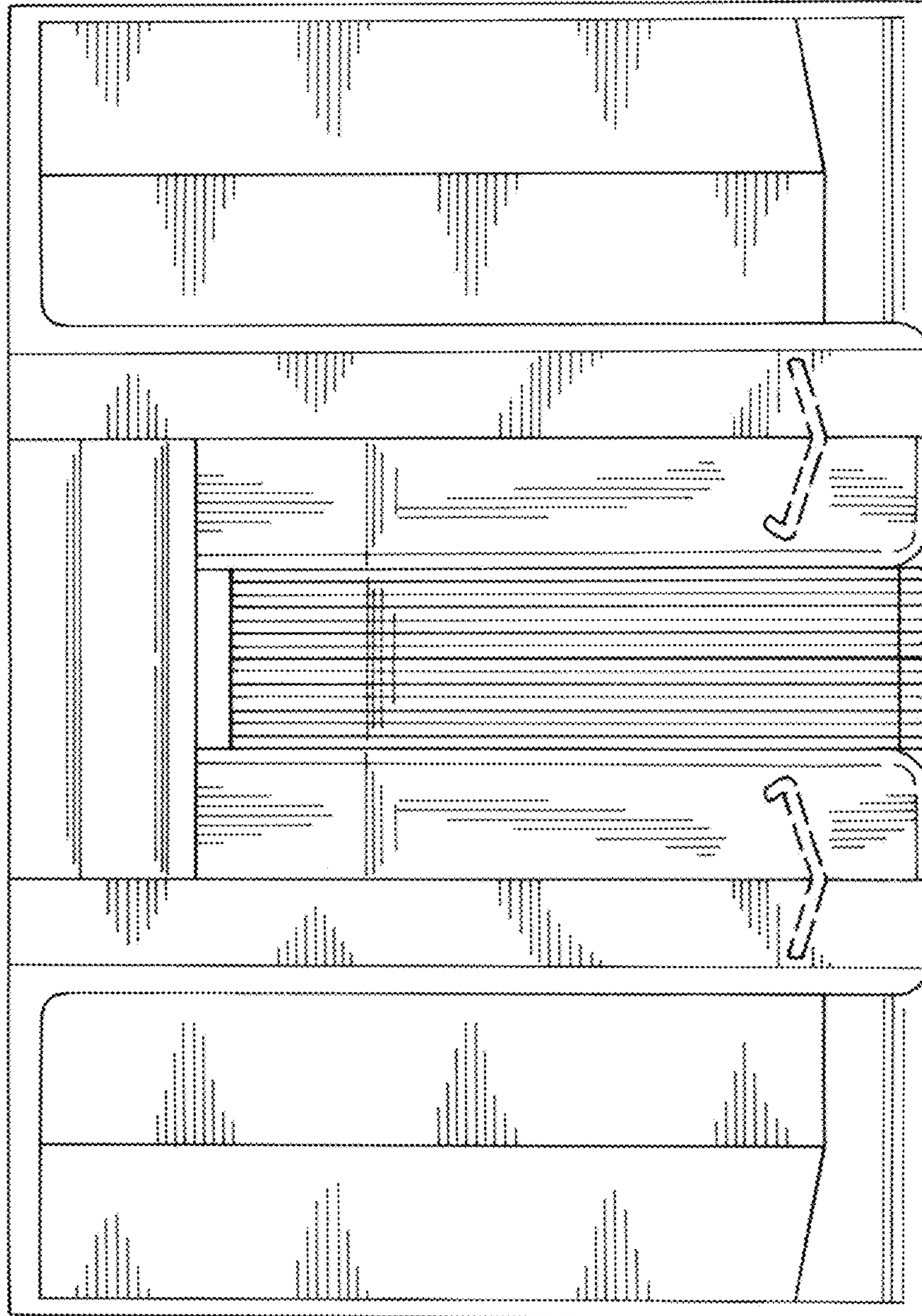

FIG. 3



**FIG. 4**

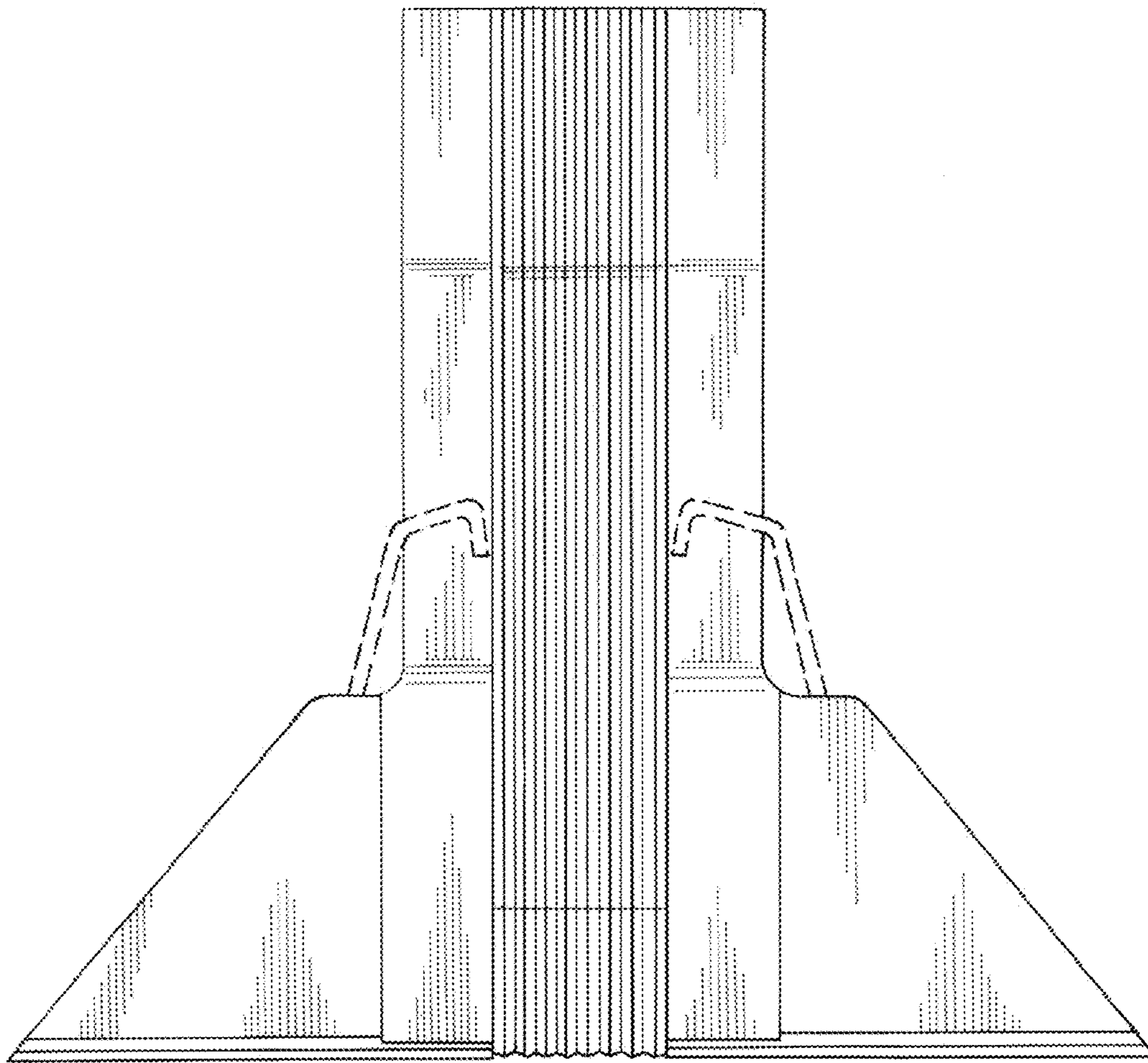

FIG. 5

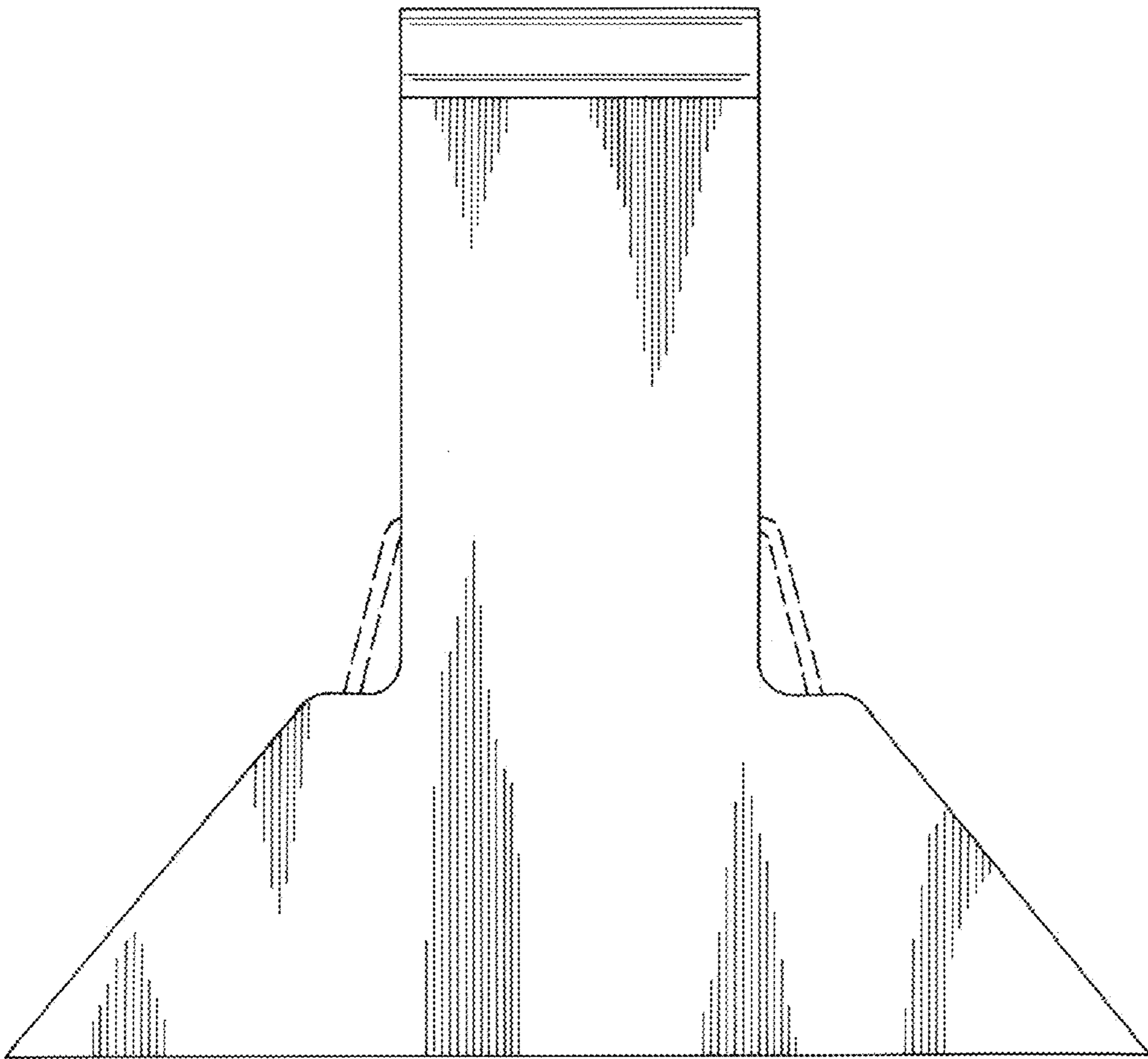

FIG. 6