



US00D680841S

(12) **United States Design Patent**  
**Bhasin**

(10) **Patent No.:** **US D680,841 S**  
(45) **Date of Patent:** **\*\* Apr. 30, 2013**

(54) **SCISSORS**

(75) Inventor: **Hanuman Prasad Bhasin**, Suita (JP)

(73) Assignee: **B.H.P. Industries Co., Ltd.**, Suita-shi (JP)

(\*\*) Term: **14 Years**

(21) Appl. No.: **29/415,161**

(22) Filed: **Mar. 8, 2012**

(30) **Foreign Application Priority Data**

Jan. 17, 2012 (JP) ..... 2012-000775

(51) **LOC (9) Cl.** ..... **08-03**

(52) **U.S. Cl.**  
USPC ..... **D8/57**

(58) **Field of Classification Search** ..... D8/4, 5,  
D8/51-58, 105, 107; D21/532; D27/195;  
D28/44, 57; D7/693; D24/148; 30/131,  
30/195, 229, 194, 230-235, 268, 350, 254-258;  
7/135, 136

See application file for complete search history.

(56) **References Cited**

U.S. PATENT DOCUMENTS

D256,215 S \* 8/1980 Chen ..... D8/57  
D280,283 S \* 8/1985 Asano ..... D8/57

D398,501 S *	9/1998	Jacquet	.....	D8/57
D398,502 S *	9/1998	Jacquet	.....	D8/57
D400,413 S *	11/1998	Jacquet	.....	D8/57
D431,436 S *	10/2000	Gstalder	.....	D8/57
D455,941 S *	4/2002	Gstalder	.....	D8/57
D518,345 S *	4/2006	Peterson	.....	D8/57
D571,632 S *	6/2008	Peterson et al.	.....	D8/57
D614,008 S *	4/2010	Hyp	.....	D8/57
D651,491 S *	1/2012	Hanakawa et al.	.....	D8/57
D651,492 S *	1/2012	Hanakawa et al.	.....	D8/57
2007/0124945 A1 *	6/2007	Hirai	.....	30/350

\* cited by examiner

*Primary Examiner* — Deanna L Fluegeman

(74) *Attorney, Agent, or Firm* — W. F. Fasse

(57) **CLAIM**

The ornamental design for a scissors, as shown and described.

**DESCRIPTION**

FIG. 1 is a front view of a scissors showing my new design;  
FIG. 2 is a rear view thereof;  
FIG. 3 is a top plan view thereof;  
FIG. 4 is a bottom plan view thereof;  
FIG. 5 is a left side view thereof;  
FIG. 6 is a right side view thereof;  
FIG. 7 is an end view of the sectioned part taken along the  
arrowed line 7-7 thereof; and,  
FIG. 8 is a front view thereof showing the opened state.

**1 Claim, 4 Drawing Sheets**

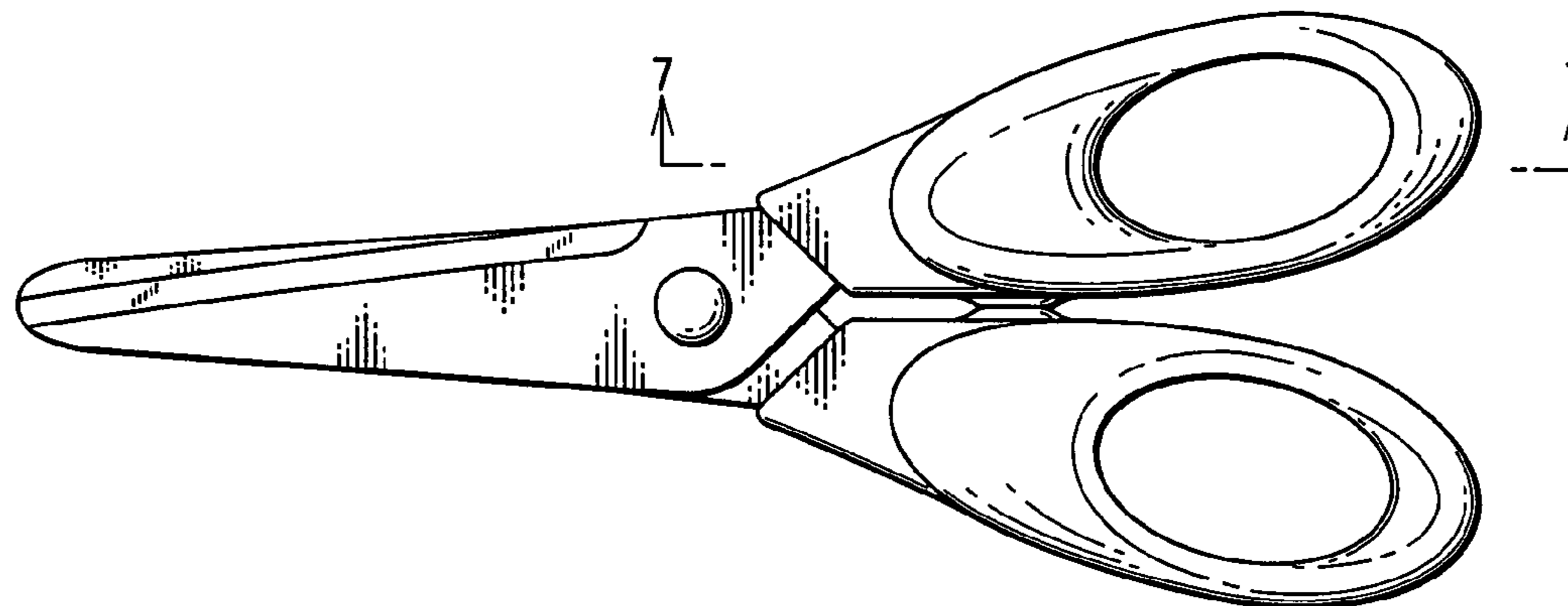

FIG.1

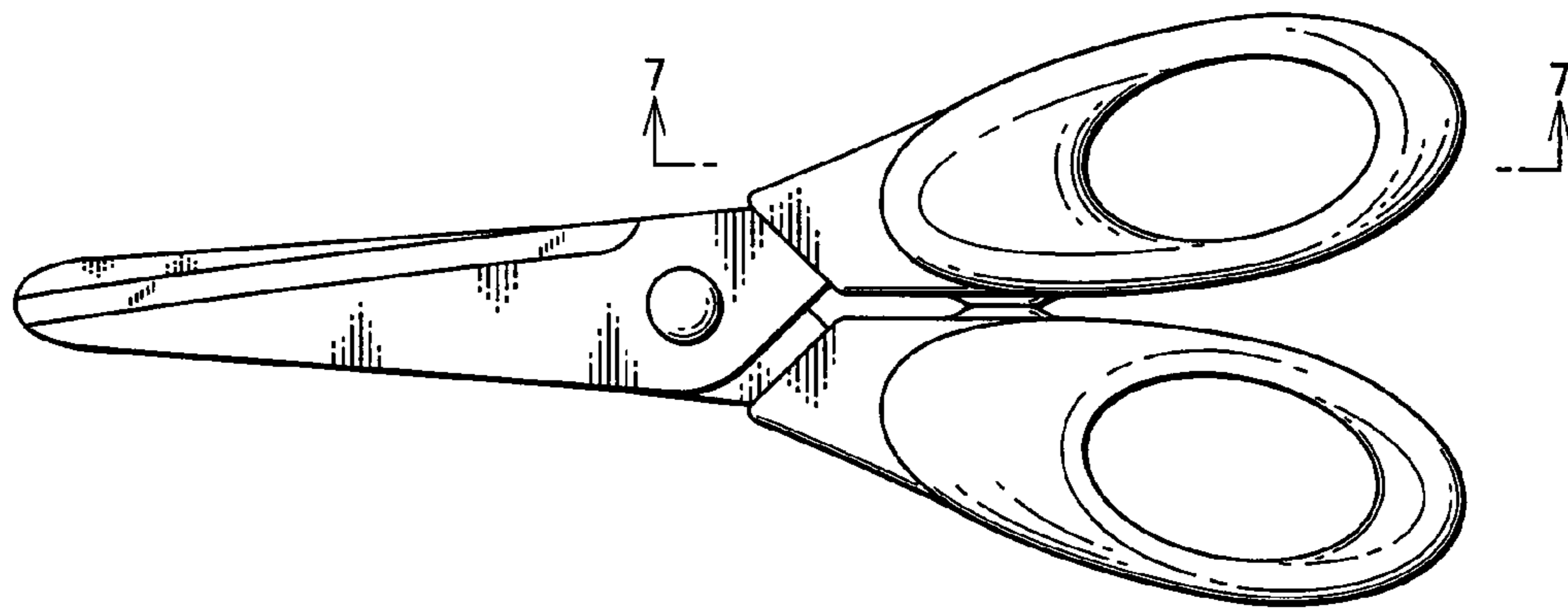

FIG.2

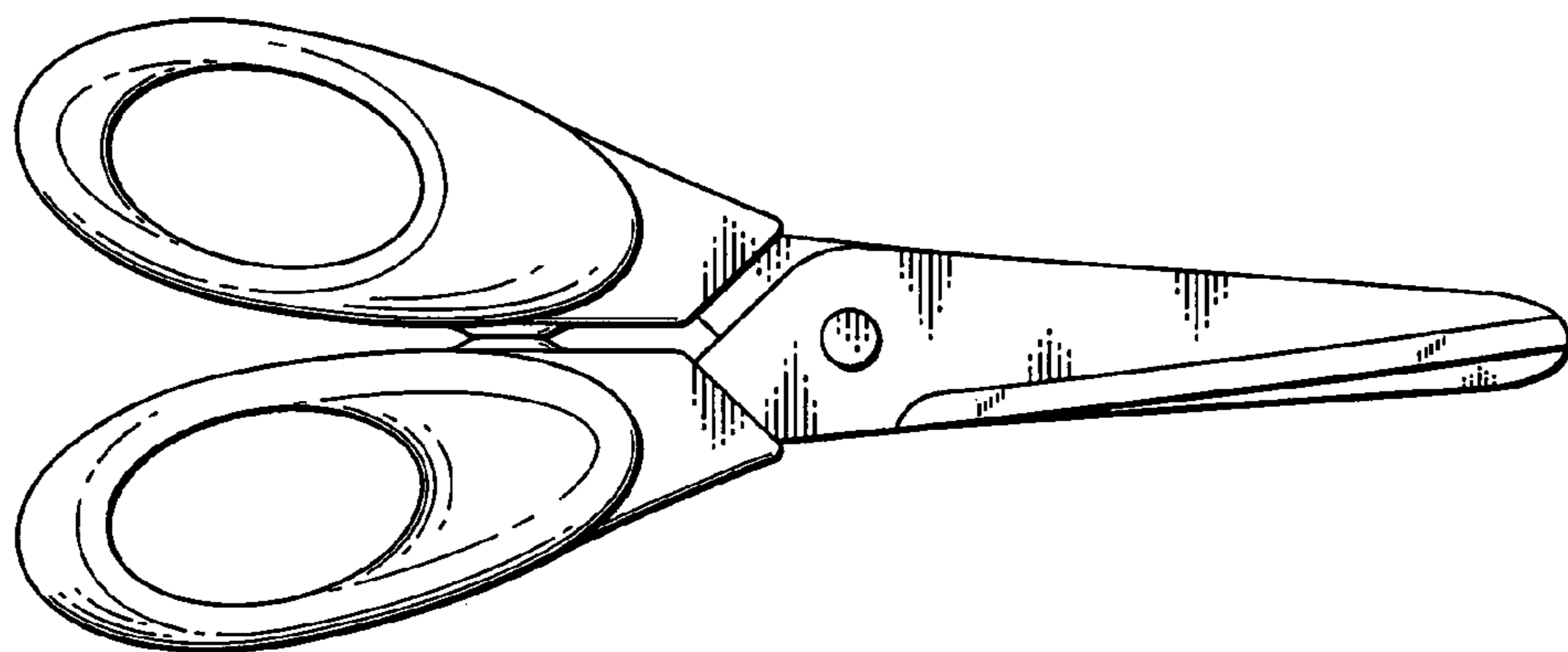

FIG.3

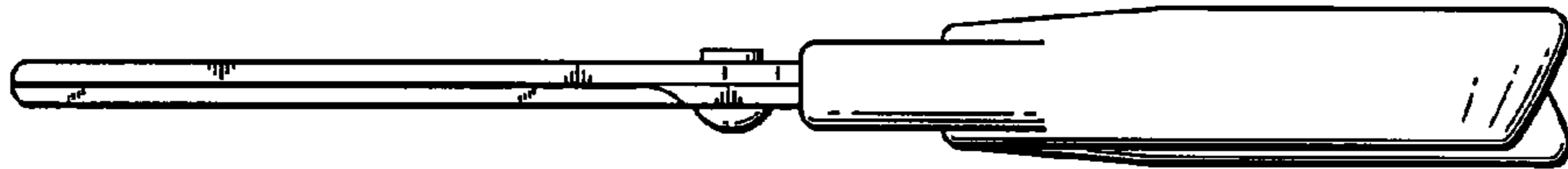

FIG.4

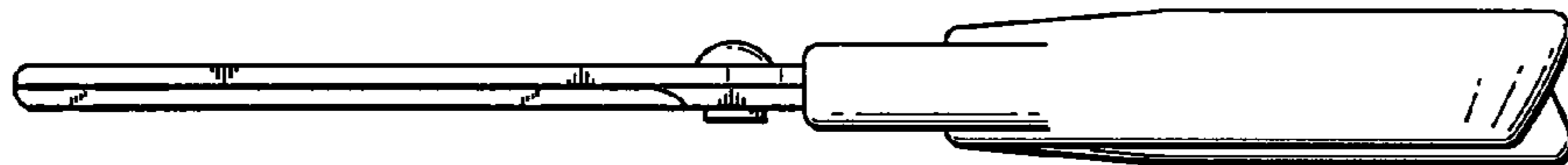

FIG.5

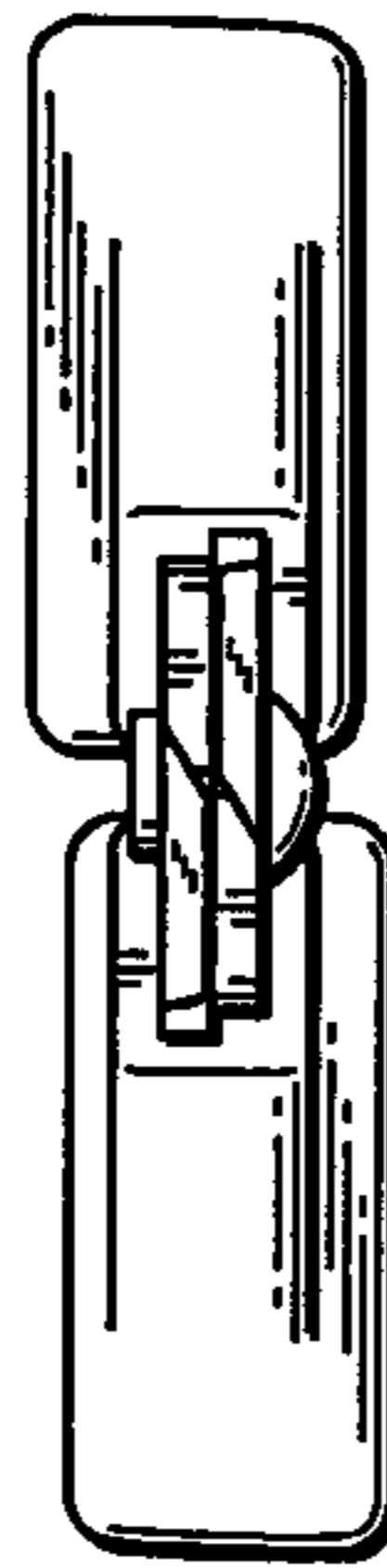

FIG.6

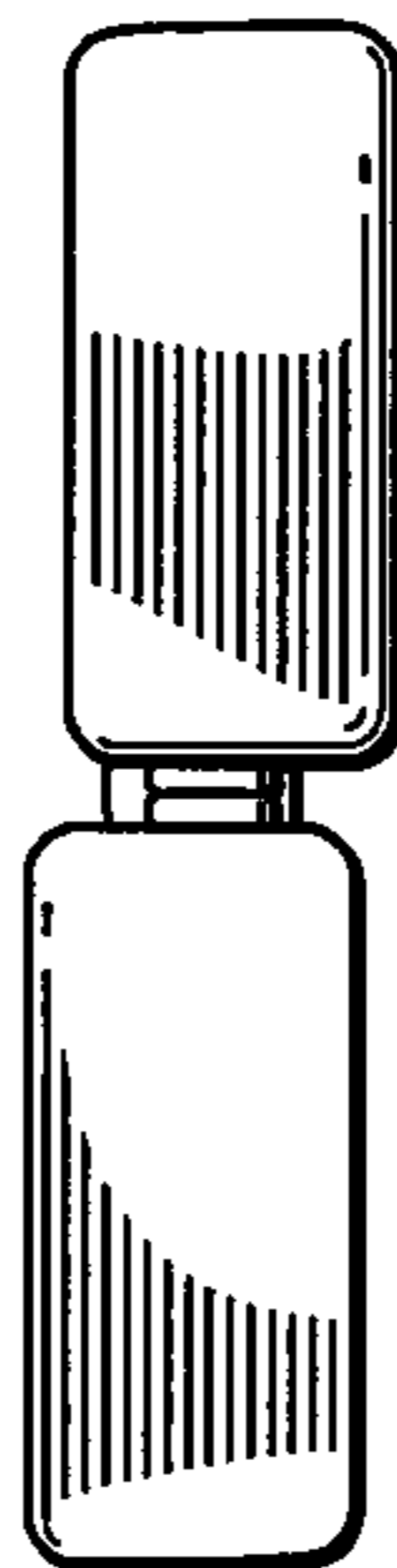

FIG.7



FIG.8

