



US00D680810S

(12) **United States Design Patent**  
**Frank, III**

(10) **Patent No.:** **US D680,810 S**

(45) **Date of Patent:** **\*\* Apr. 30, 2013**

(54) **COOKER DRIP PAN**

(75) Inventor: **Robert Lee Frank, III**, Woodstock, GA  
(US)

(73) Assignee: **Falling Brook, LLC**, Woodstock, GA  
(US)

(\*\*) Term: **14 Years**

(21) Appl. No.: **29/420,638**

(22) Filed: **May 11, 2012**

(51) **LOC (9) Cl.** ..... **07-02**

(52) **U.S. Cl.**  
USPC ..... **D7/407**

(58) **Field of Classification Search** ..... D7/402-408,  
D7/550.1, 558, 354, 396.6, 363, 360, 543,  
D7/545, 416-417; 126/25 R, 9 R, 41 R,  
126/38, 39 K, 40, 50, 348, 544, 548, 555;  
99/422, 425, 444, 446, 447; 428/98, 131;  
D23/393, 415-420, 403-410

See application file for complete search history.

(56) **References Cited**

U.S. PATENT DOCUMENTS

3,972,318 A \* 8/1976 Lenoir ..... 126/348  
D267,922 S \* 2/1983 Schweizer ..... D7/363

D282,139 S \* 1/1986 Radford ..... D7/360  
D320,531 S \* 10/1991 Schweitzer ..... D7/402  
D345,890 S \* 4/1994 Majors ..... D7/402  
D483,224 S \* 12/2003 Clark ..... D7/402  
D555,780 S \* 11/2007 Wanninger ..... D23/393  
D608,588 S \* 1/2010 Womack ..... D7/407  
D642,257 S \* 7/2011 Mann ..... D23/418  
D666,055 S \* 8/2012 O'Neil ..... D7/407

\* cited by examiner

*Primary Examiner* — T. Chase Nelson

*Assistant Examiner* — Mark Cavanna

(74) *Attorney, Agent, or Firm* — Taylor English Duma LLP

(57) **CLAIM**

I claim the ornamental design for a cooker drip pan, as shown and described.

**DESCRIPTION**

FIG. 1 is a perspective view of a cooker drip pan of the design described herein.

FIG. 2 is a side view thereof.

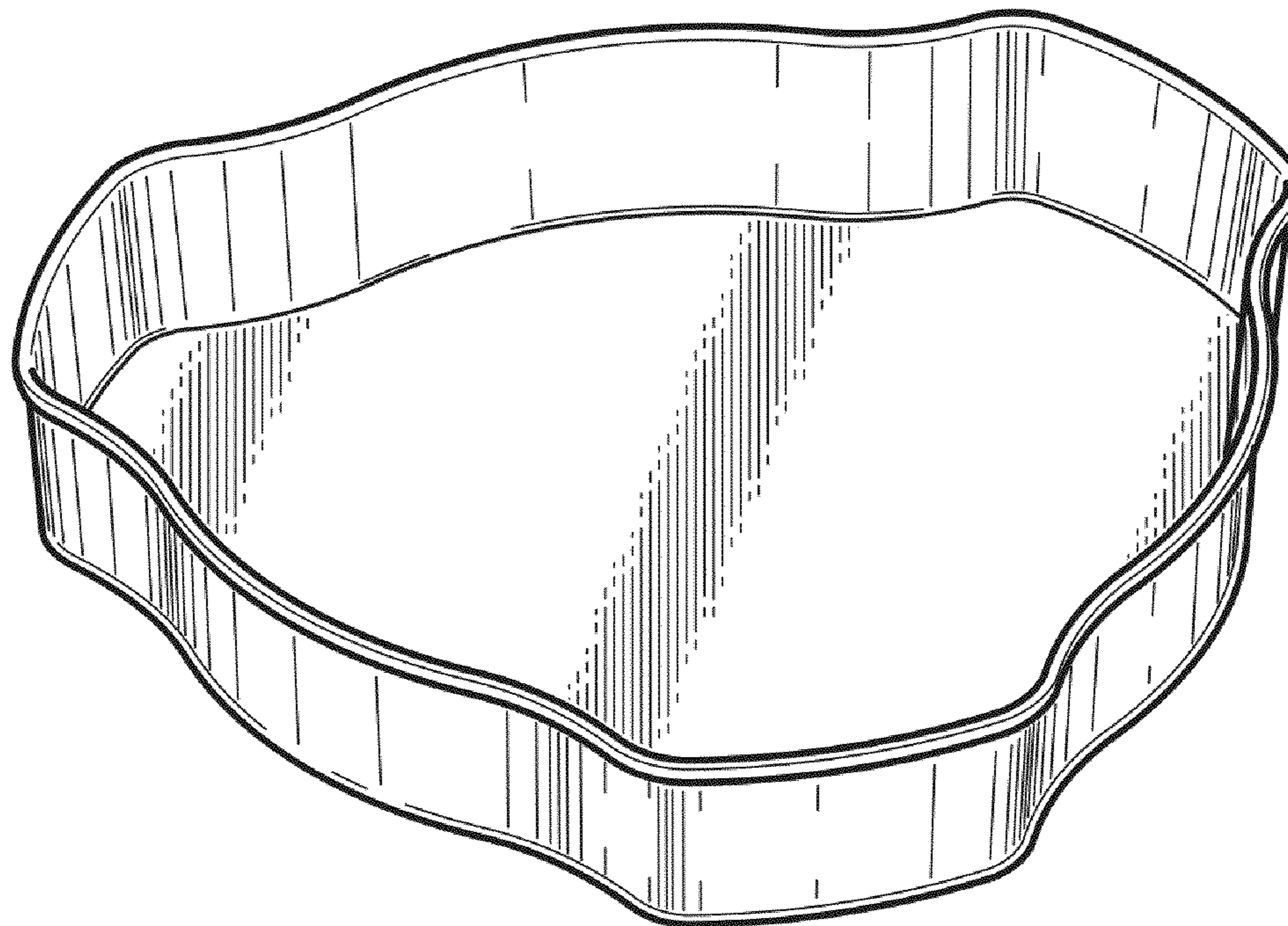
FIG. 3 is a front view thereof.

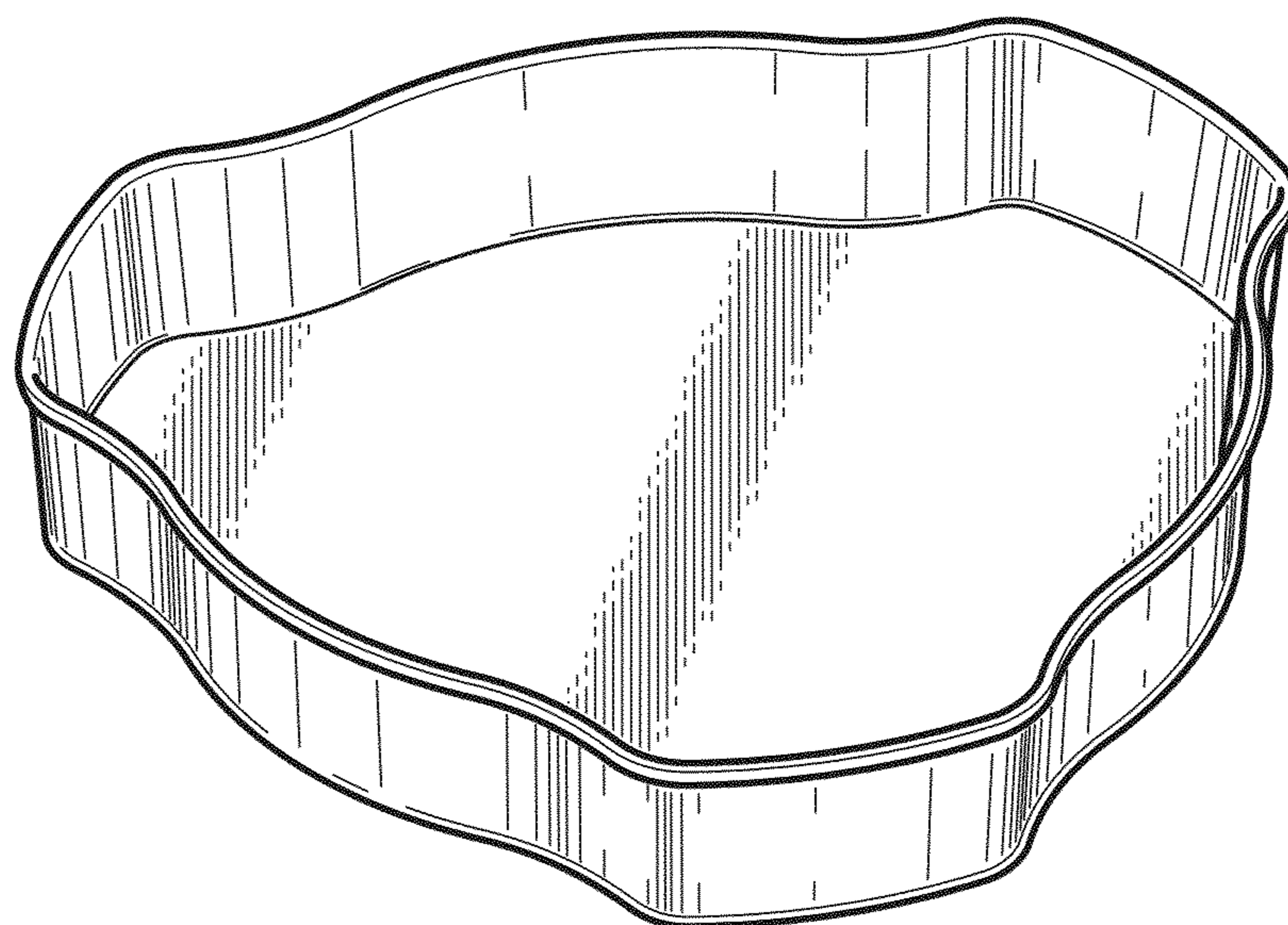
FIG. 4 is a back view thereof.

FIG. 5 is a top view thereof; and,

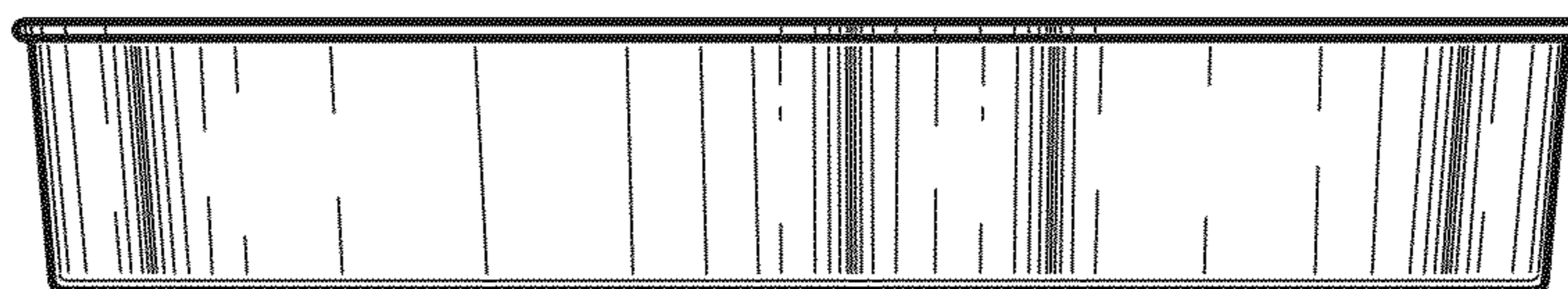
FIG. 6 is a bottom view thereof.

**1 Claim, 2 Drawing Sheets**

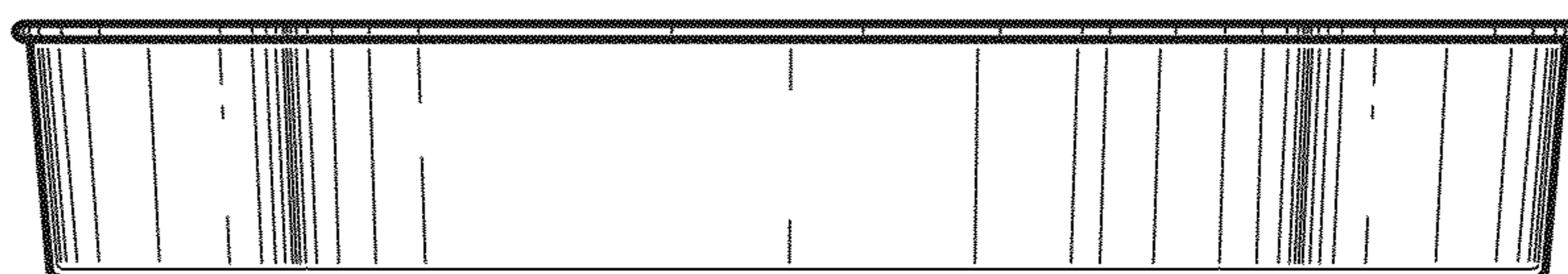




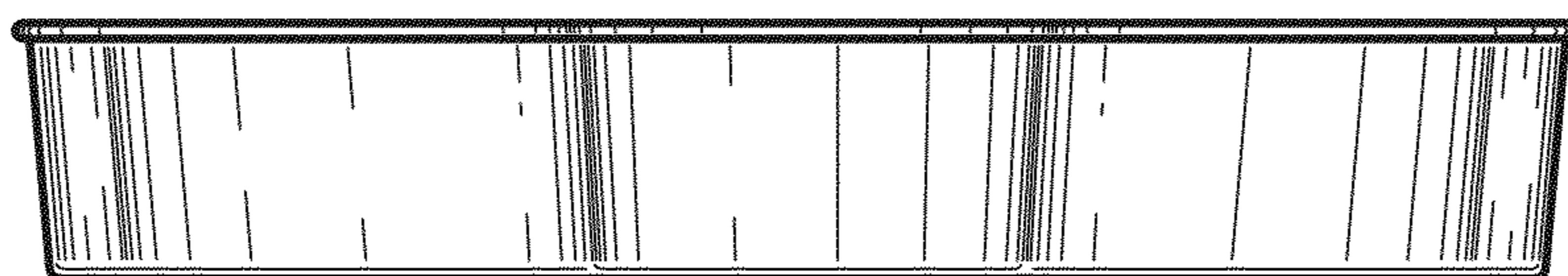
**FIG. 1**



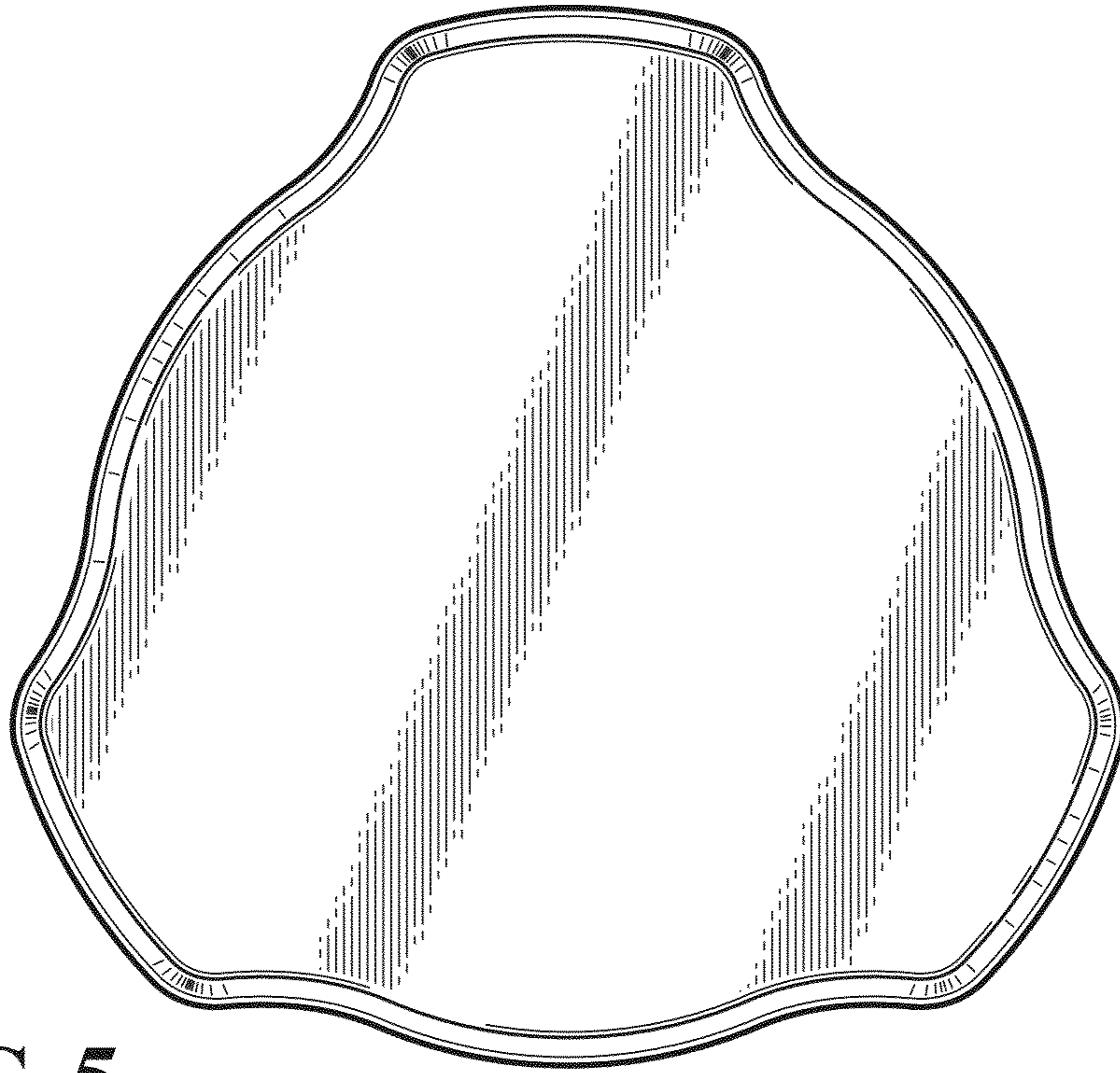
**FIG. 2**



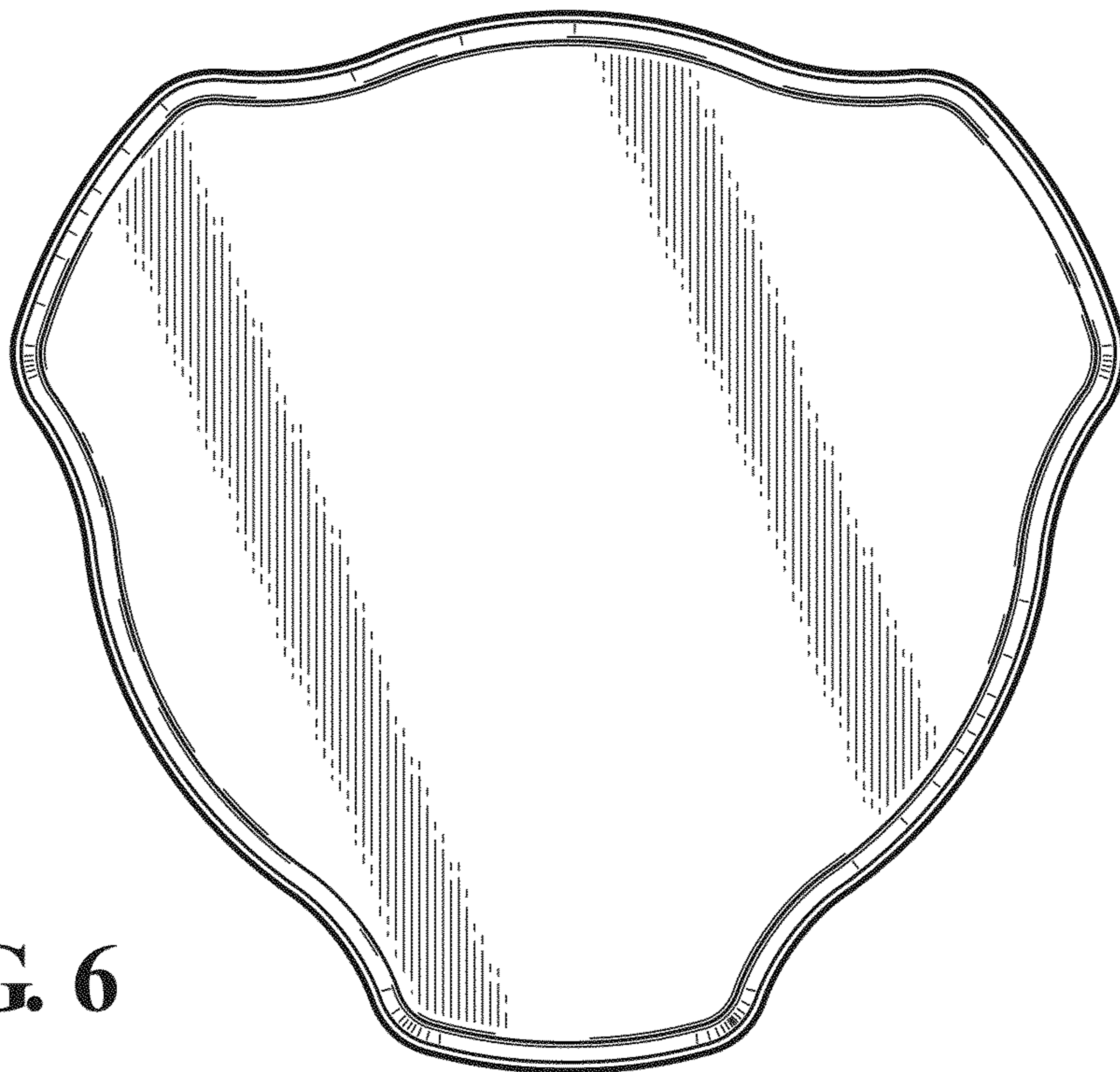
**FIG. 3**



**FIG. 4**



**FIG. 5**



**FIG. 6**