



US00D680554S

(12) **United States Design Patent**  
**Harriton**

(10) **Patent No.:** **US D680,554 S**  
(45) **Date of Patent:** **\*\* Apr. 23, 2013**

- (54) **SNORKEL**
- (75) Inventor: **David Harriton**, Missoula, MT (US)
- (73) Assignee: **Streetcar ORV LLC**, Wixom, MI (US)
- (\*\*) Term: **14 Years**
- (21) Appl. No.: **29/418,862**
- (22) Filed: **Apr. 23, 2012**
- (51) **LOC (9) Cl.** ..... **15-01**
- (52) **U.S. Cl.**  
USPC ..... **D15/5; D12/400**
- (58) **Field of Classification Search** ..... D15/1-6;  
123/184.21, 184.24, 184.34, 184.35, 23.2,  
123/184.48, 184.42; D12/400, 194, 206,  
D12/418; D24/110.5, 110.6  
See application file for complete search history.

D637,623 S	5/2011	Luxon et al.	
D638,446 S	5/2011	Luxon et al.	
D641,377 S	7/2011	Luxon et al.	
D646,611 S	10/2011	Schell et al.	
D648,745 S	11/2011	Luxon et al.	
D649,162 S	11/2011	Luxon et al.	
2010/0229817 A1*	9/2010	Hirai	123/184.21
2010/0229818 A1	9/2010	Silvano	

\* cited by examiner

*Primary Examiner* — T. Chase Nelson  
*Assistant Examiner* — Ania Aman  
(74) *Attorney, Agent, or Firm* — Quinn Law Group PLLC

(57) **CLAIM**  
I claim the ornamental design for a snorkel, as shown and described.

**DESCRIPTION**

FIG. 1 is a right side, rear perspective view of a snorkel illustrated as being attached to a right side of a vehicle, FIG. 2 is a front right side perspective view of the snorkel of FIG. 1, FIG. 3 is a front left side perspective view of the snorkel of FIG. 1, FIG. 4 is a left side view of the snorkel of FIG. 1, FIG. 5 is a right side view of the snorkel of FIG. 1, FIG. 6 is a top view of the snorkel of FIG. 1, FIG. 7 is a bottom view of the snorkel of FIG. 1, FIG. 8 is a rear view of the snorkel of FIG. 1; and, FIG. 9 is a front view of the snorkel of FIG. 1. All broken lines illustrate portions of the snorkel to which the design is applied that form no part of the claim.

**1 Claim, 8 Drawing Sheets**

- (56) **References Cited**  
U.S. PATENT DOCUMENTS
- |              |         |               |
|--------------|---------|---------------|
| D266,167 S   | 9/1982  | Lindbrandt    |
| D357,665 S   | 4/1995  | Creyts        |
| 6,564,766 B2 | 5/2003  | Ayton         |
| 6,637,537 B2 | 10/2003 | Porter et al. |
| 6,966,292 B2 | 11/2005 | Huang         |
| D532,019 S   | 11/2006 | Huang         |
| D545,725 S   | 7/2007  | Zimbardo      |
| 7,281,511 B2 | 10/2007 | Quezada       |
| D562,749 S   | 2/2008  | LaRussa       |
| D627,369 S   | 11/2010 | Troxell       |
| D636,408 S   | 4/2011  | Luxon et al.  |
| D636,787 S   | 4/2011  | Luxon et al.  |
| D636,788 S   | 4/2011  | Luxon et al.  |

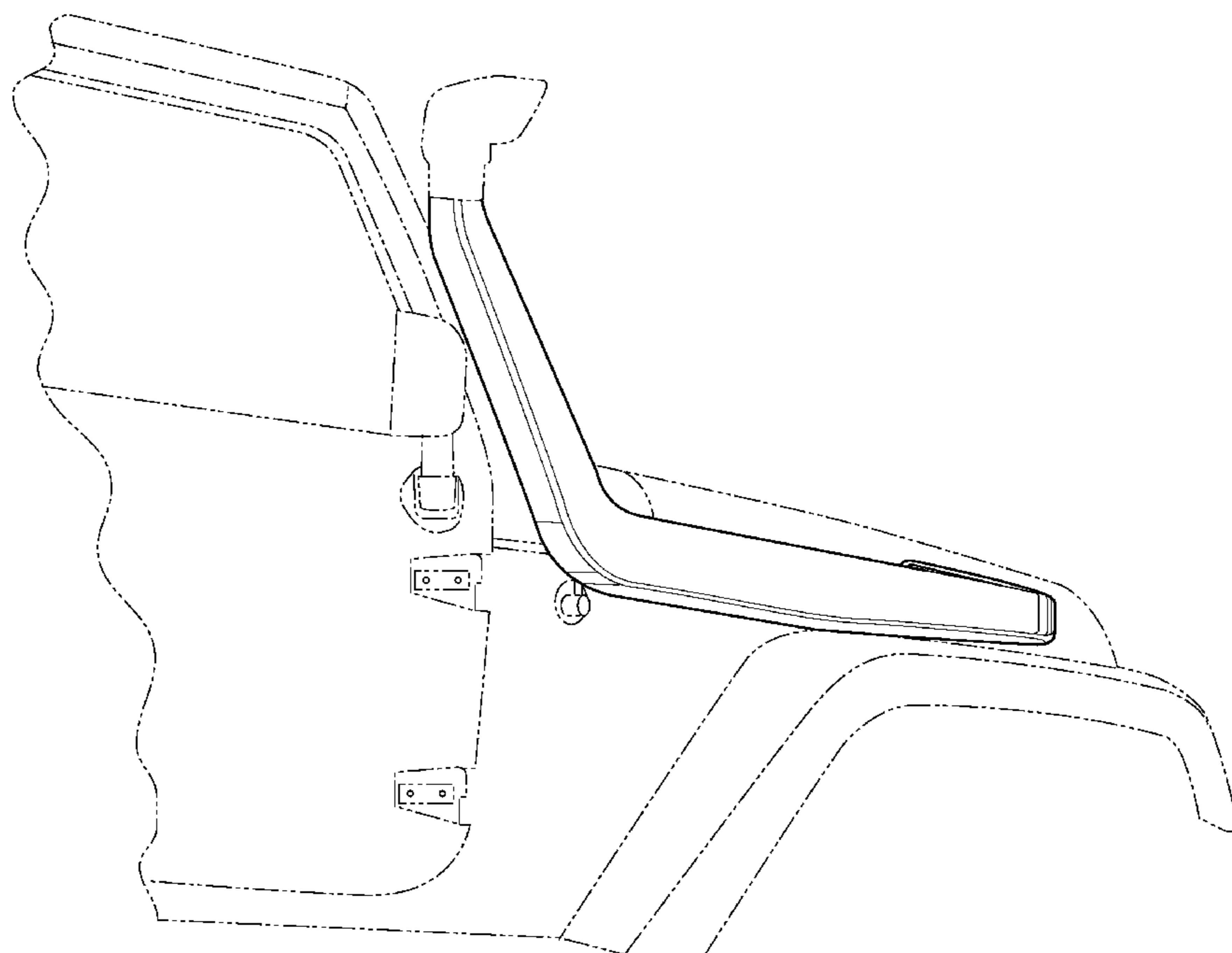
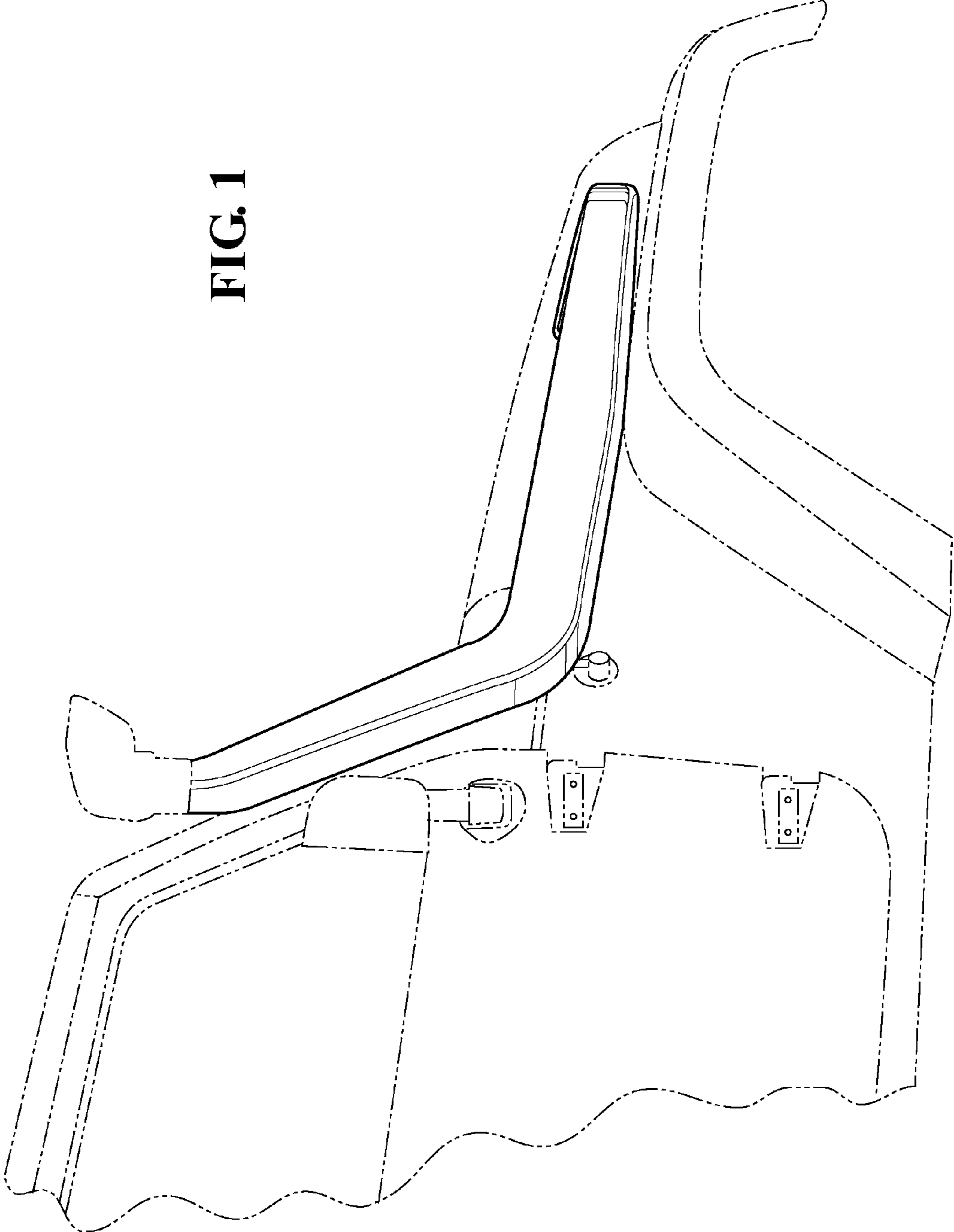

FIG. 1



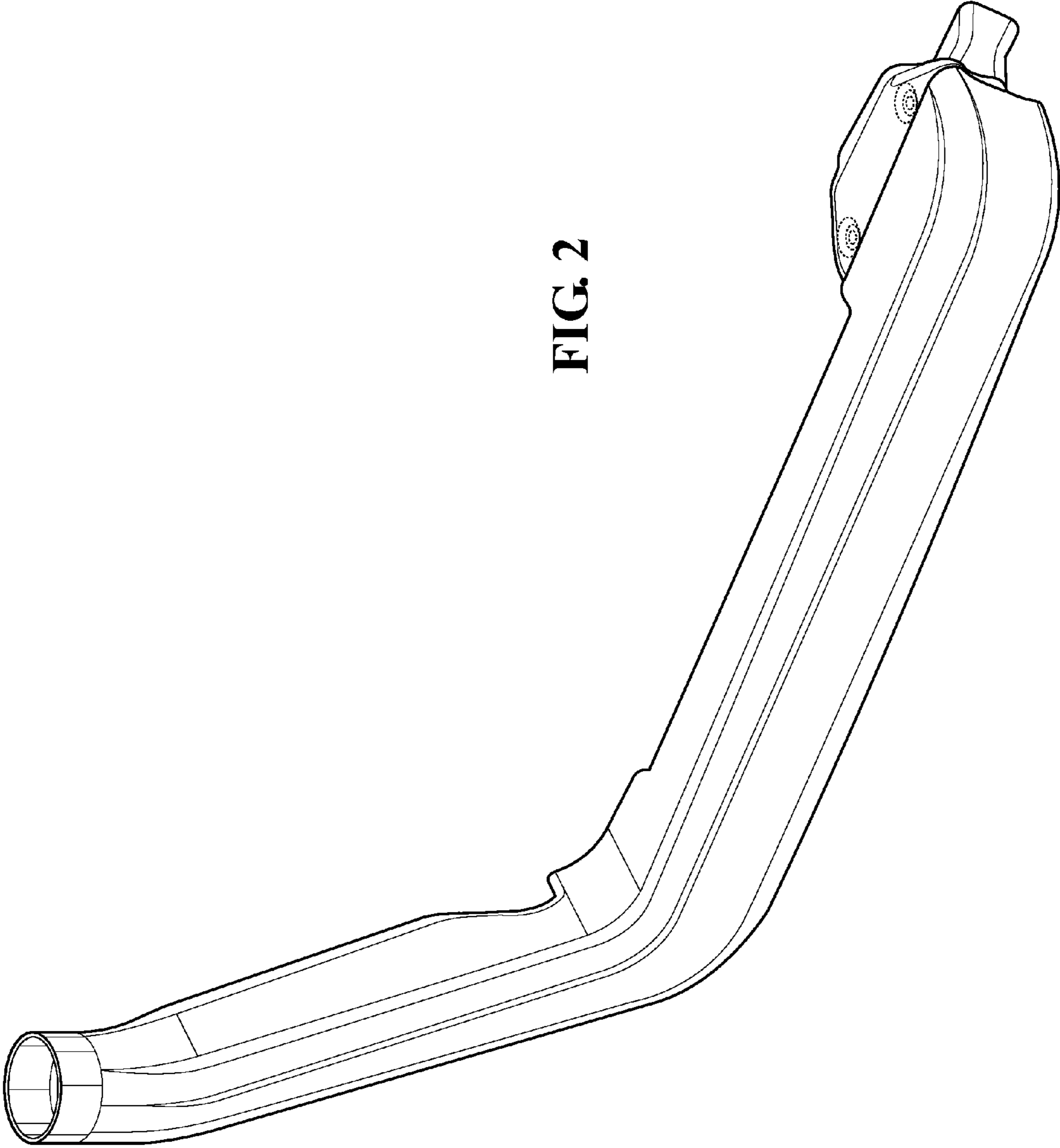

FIG. 2

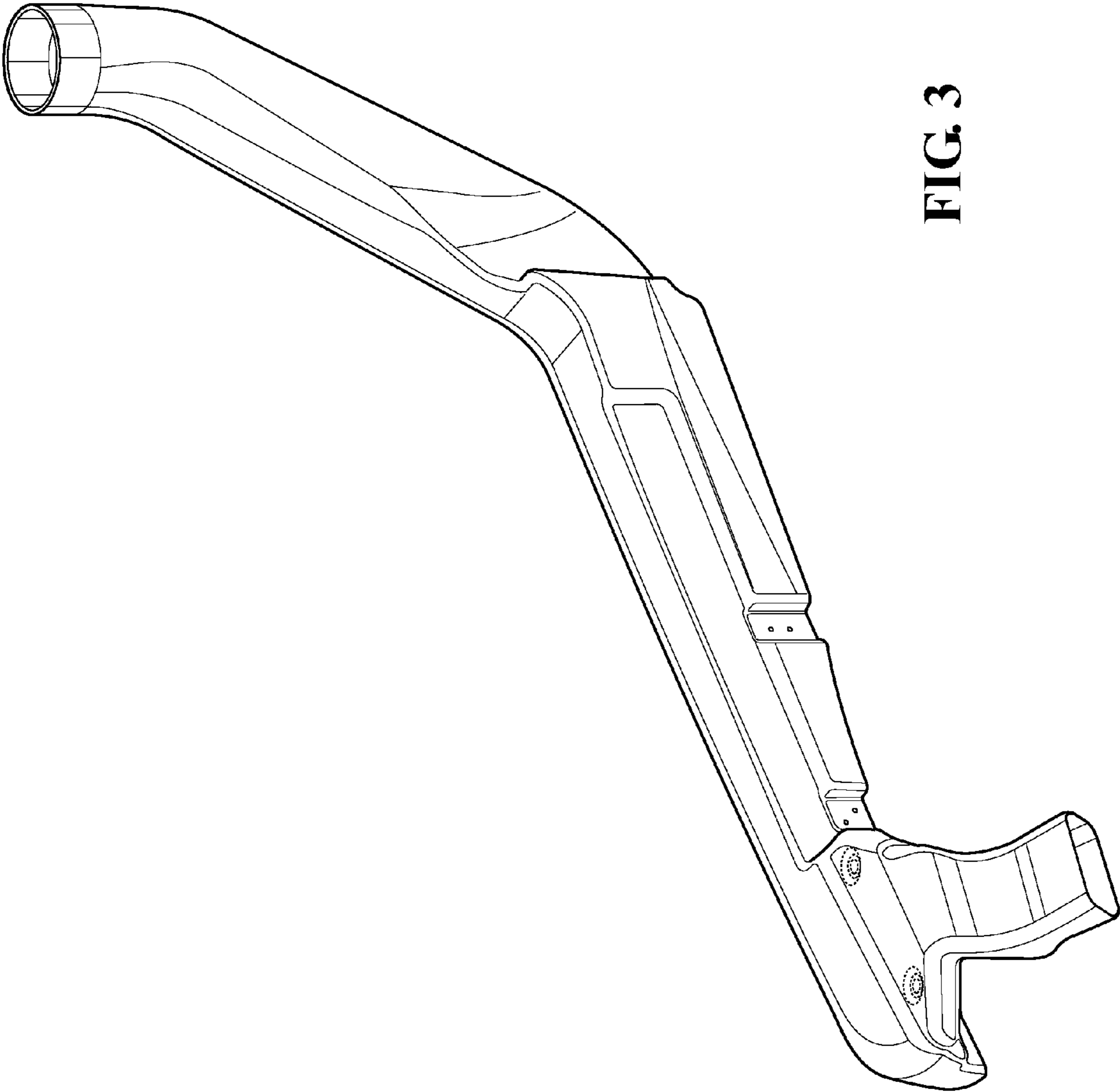

FIG. 3

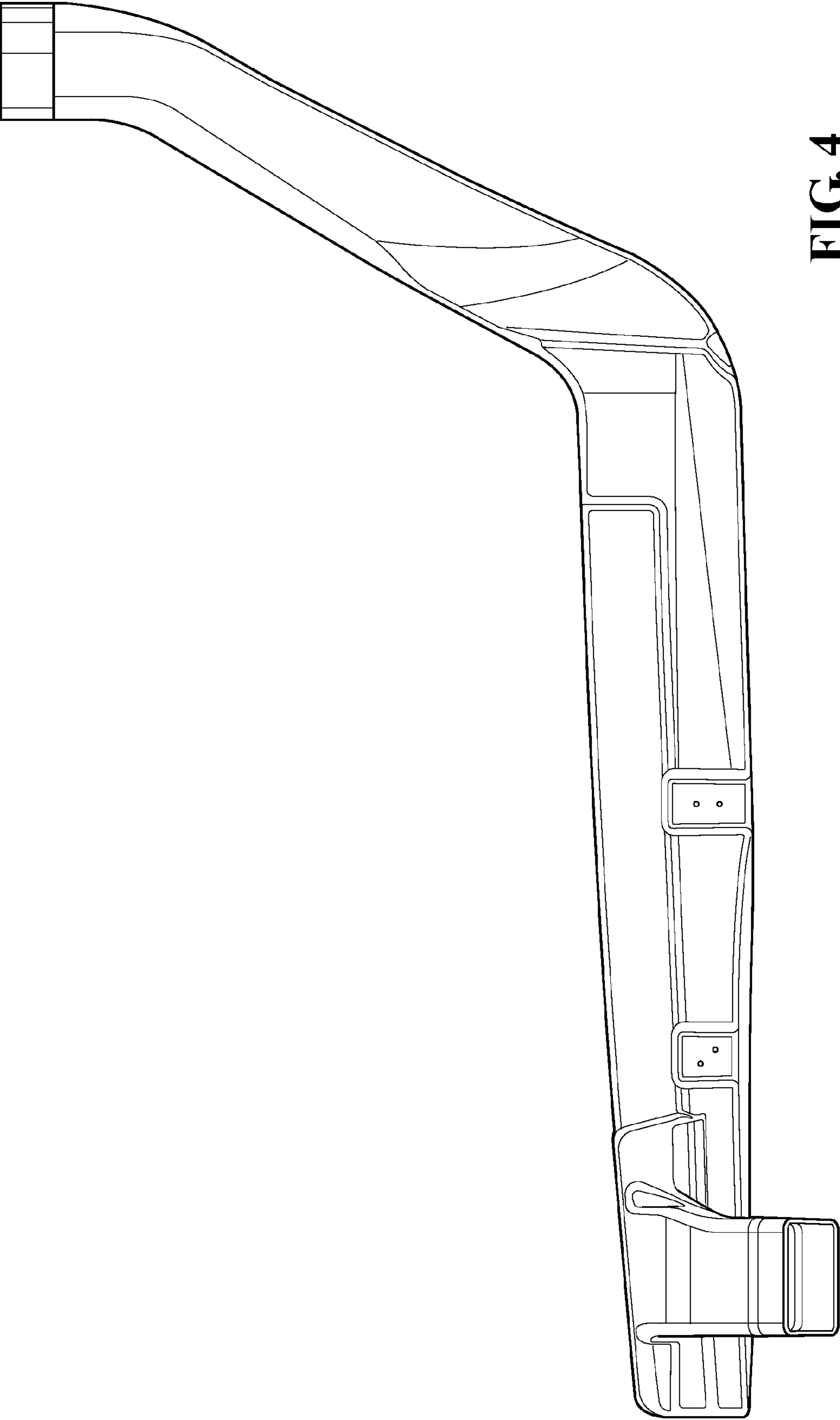

FIG. 4

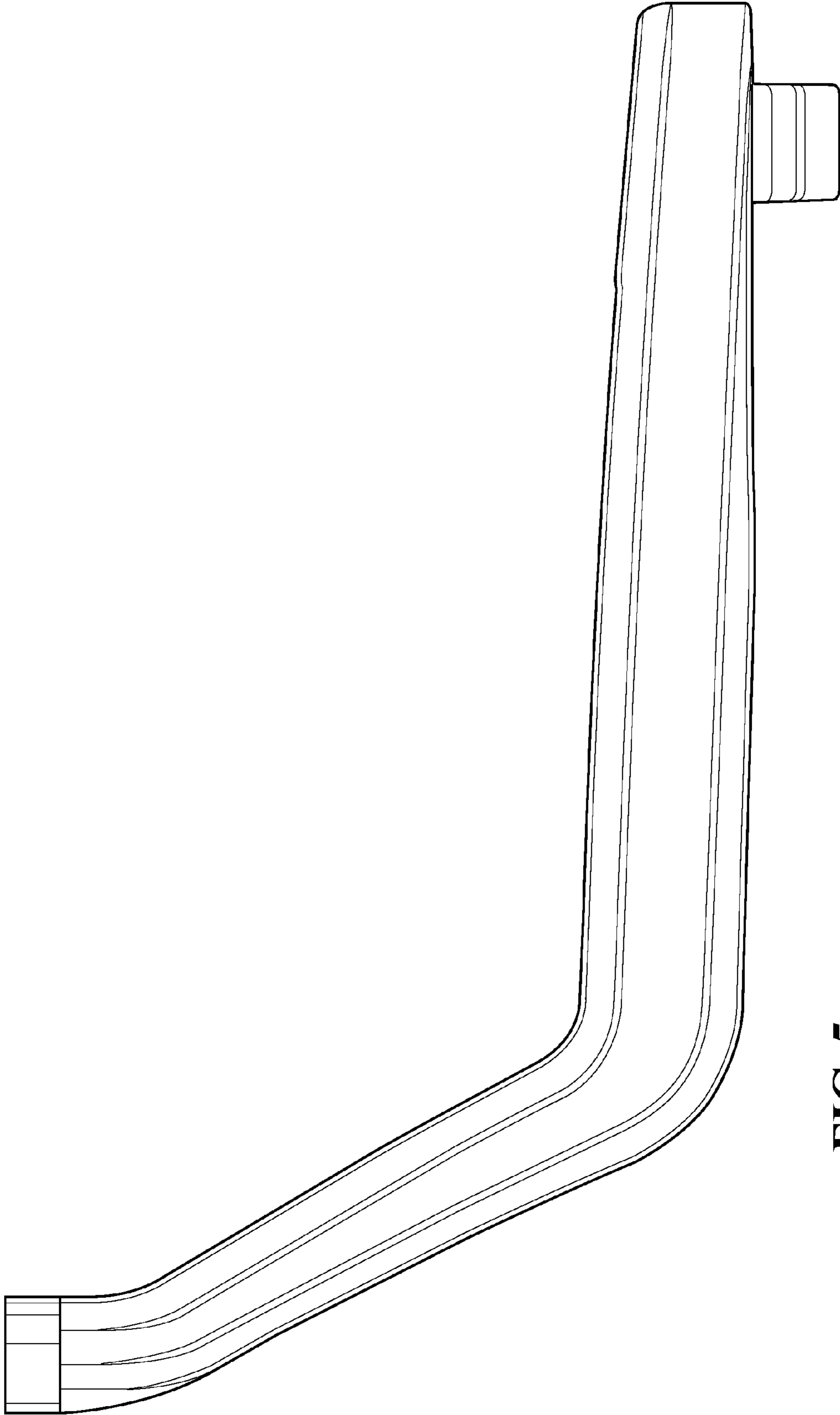

FIG. 5

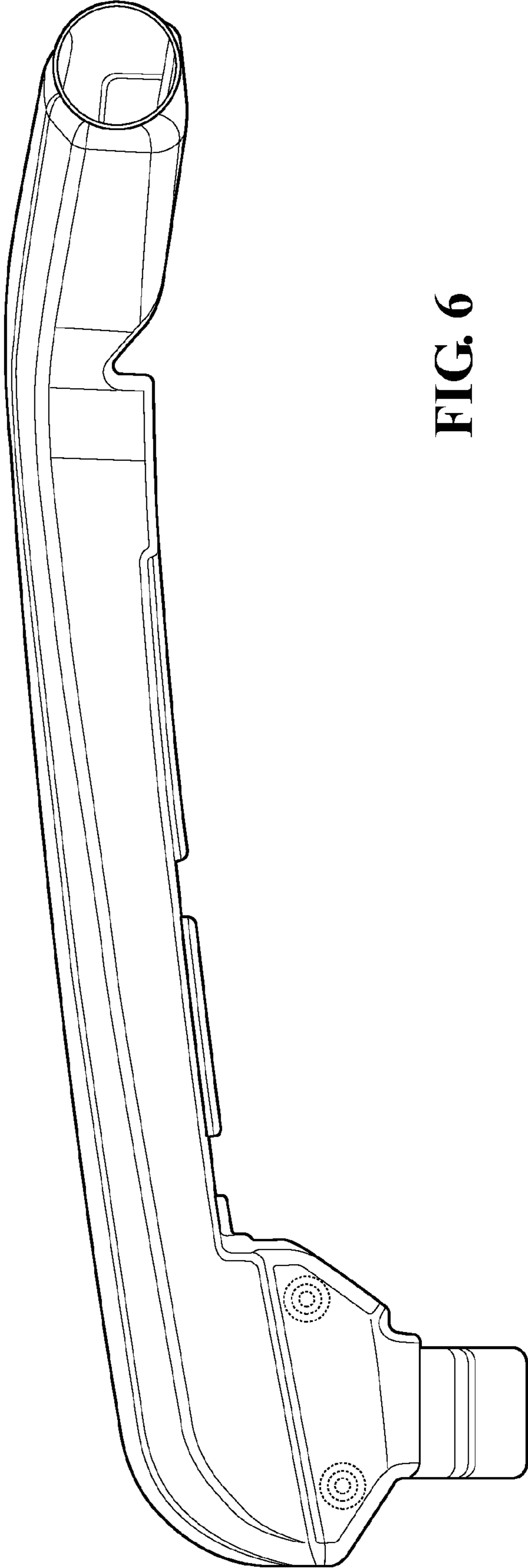

FIG. 6

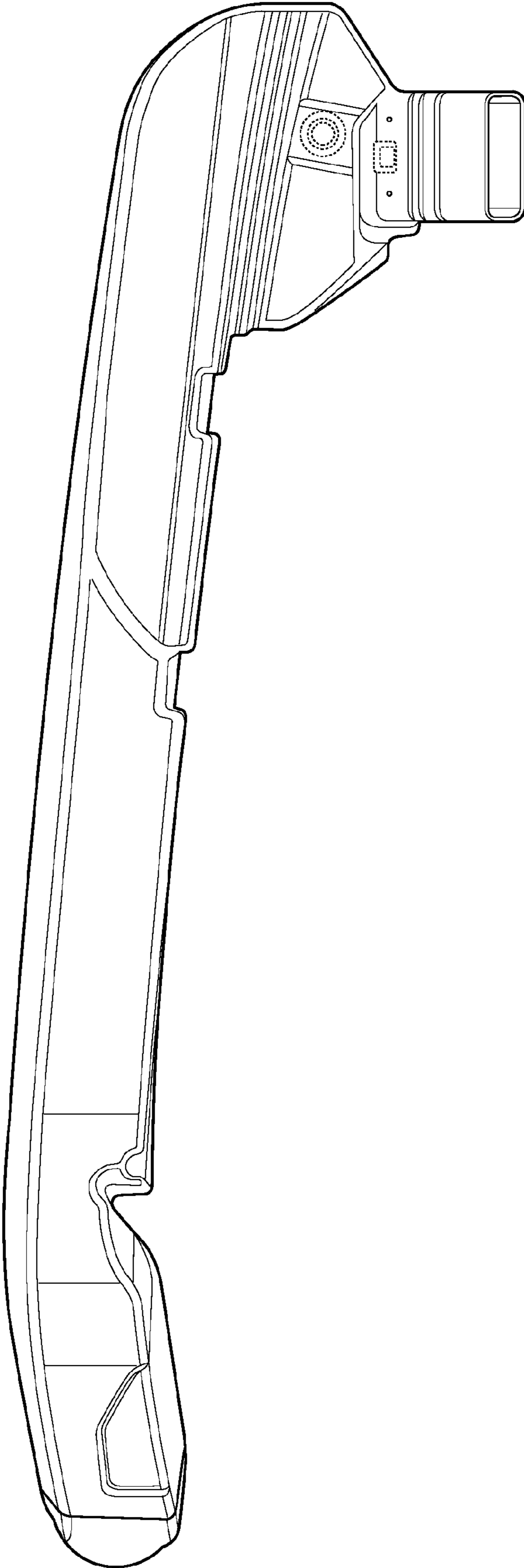

FIG. 7



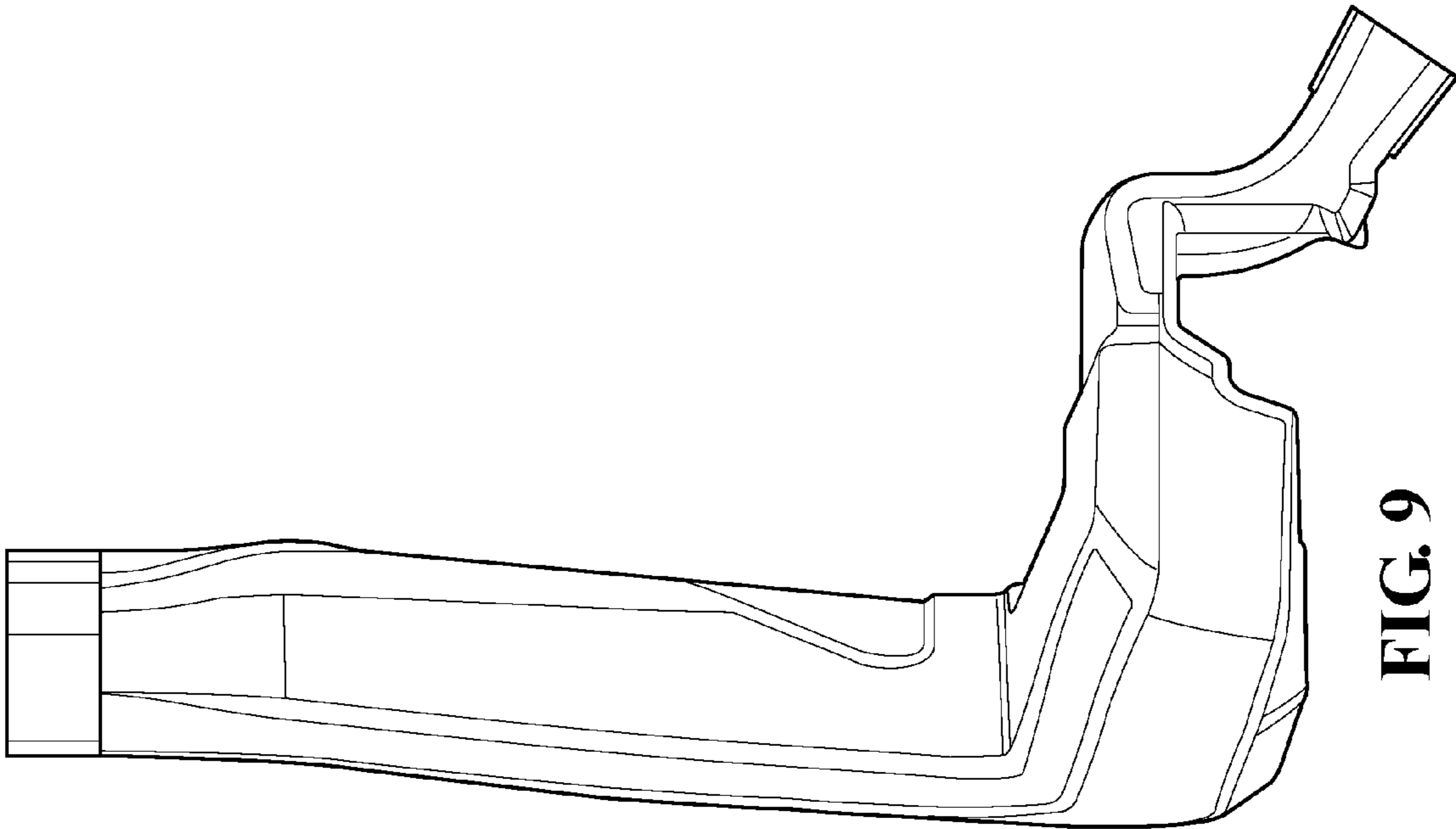

FIG. 9

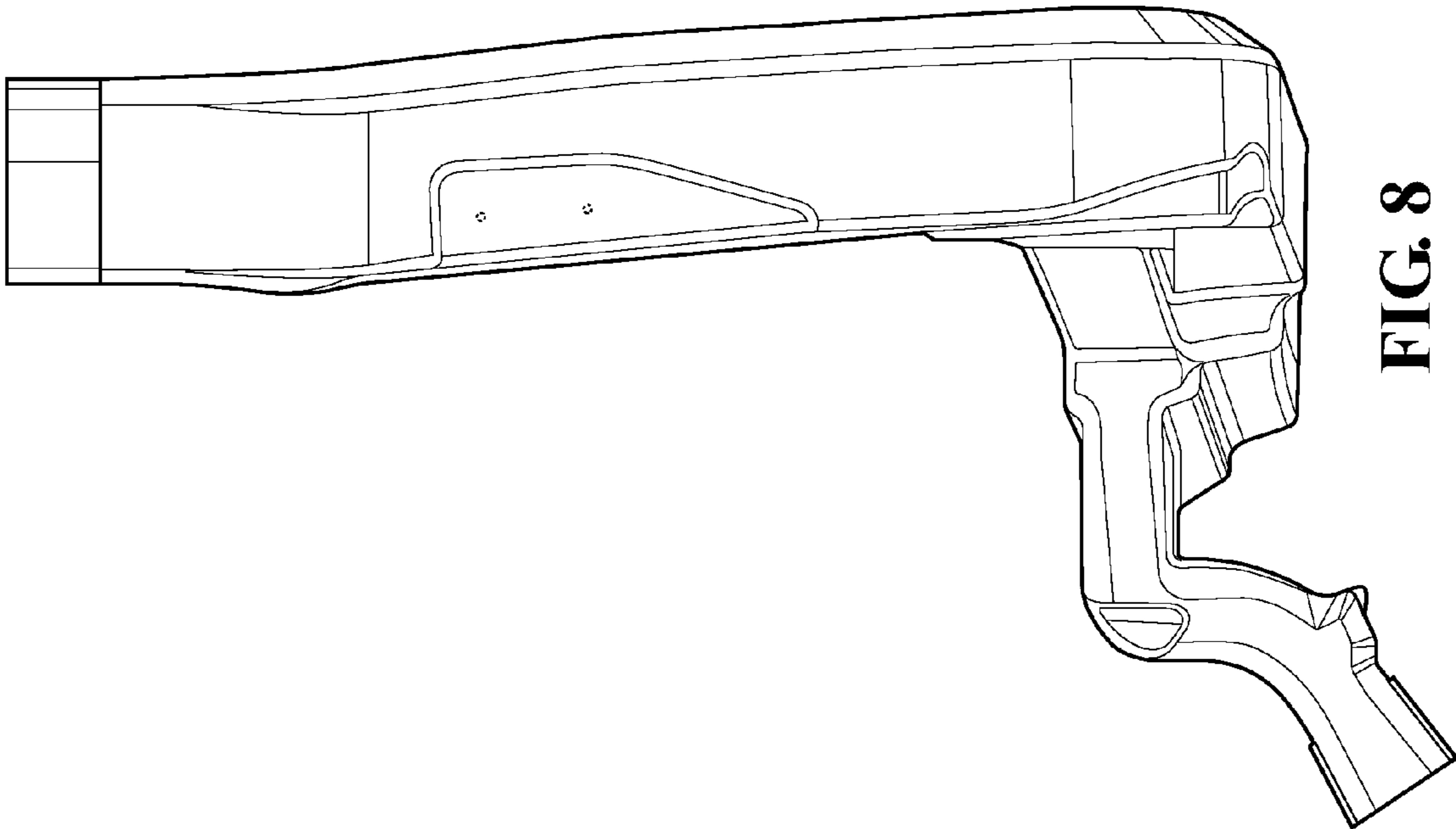

FIG. 8