



US00D680450S

(12) **United States Design Patent**
Shimizu

(10) **Patent No.:** **US D680,450 S**
(45) **Date of Patent:** **** Apr. 23, 2013**

(54) **IN-VEHICLE POSITION MEASUREMENT
DRIVING GUIDANCE SYSTEM**

(75) Inventor: **Akari Shimizu**, Saitama (JP)

(73) Assignee: **Clarion Co., Ltd.**, Saitama (JP)

(**) Term: **14 Years**

(21) Appl. No.: **29/410,924**

(22) Filed: **Jan. 13, 2012**

Related U.S. Application Data

(62) Division of application No. 29/394,667, filed on Jun. 20, 2011, now Pat. No. Des. 657,699.

(30) **Foreign Application Priority Data**

Dec. 20, 2010 (JP) 2010-30431

(51) **LOC (9) Cl.** **10-04**

(52) **U.S. Cl.**
USPC **D10/65; D10/70**

(58) **Field of Classification Search** D10/65,
D10/70, 75, 76; D14/347, 136, 167, 168,
D14/496, 498, 499, 500, 125-134, 239, 371,
D14/374-377, 440, 450, 448, 336, 342; 343/702;
345/87, 104, 133, 156, 168, 173, 901-905;
348/180, 184, 315, 739, 836, 838, 325; 364/444,
364/499; 701/408-418, 431, 432, 537; 312/7.2;
341/12; 720/605, 669, 600, 655; 369/99,
369/197; 455/344, 347

See application file for complete search history.

(56) **References Cited**

U.S. PATENT DOCUMENTS

D532,399 S * 11/2006 Sogabe et al. D14/132
D550,637 S * 9/2007 Iwamoto et al. D14/132
D564,473 S * 3/2008 Nemoto D14/129

D572,218 S * 7/2008 Iwamoto D14/132
D575,251 S * 8/2008 Miyawaki D14/132
D577,696 S * 9/2008 Miyawaki D14/132
D577,697 S * 9/2008 Miyawaki D14/132
D578,974 S * 10/2008 Miyawaki D14/132
D580,898 S * 11/2008 Aihara D14/132
D608,229 S * 1/2010 Katsuno D10/65
D623,626 S * 9/2010 Tomono et al. D14/168
D628,544 S * 12/2010 Hirose D14/132
D630,612 S * 1/2011 Tomono et al. D14/157
D665,380 S * 8/2012 Iwamoto D14/198

* cited by examiner

Primary Examiner — Antoine D Davis

(74) *Attorney, Agent, or Firm* — Scully Scott Murphy & Presser, PC

(57) **CLAIM**

The ornamental design for an in-vehicle position measurement driving guidance system, as shown and described.

DESCRIPTION

FIG. 1 is a front perspective view showing the in-vehicle position measurement driving guidance system in use, where a display unit is deployed.

FIG. 2 is a front view of the in use configuration shown in FIG. 1;

FIG. 3 is a rear view of the in use configuration shown in FIG. 1;

FIG. 4 is a right side view of the in use configuration shown in FIG. 1;

FIG. 5 is a left side view of the in use configuration shown in FIG. 1;

FIG. 6 is a top view of the in use configuration shown in FIG. 1; and,

FIG. 7 is a bottom view of the in use configuration shown in FIG. 1.

The portions indicated in broken lines are for illustrative purposes only and form no part of the claimed design.

1 Claim, 6 Drawing Sheets

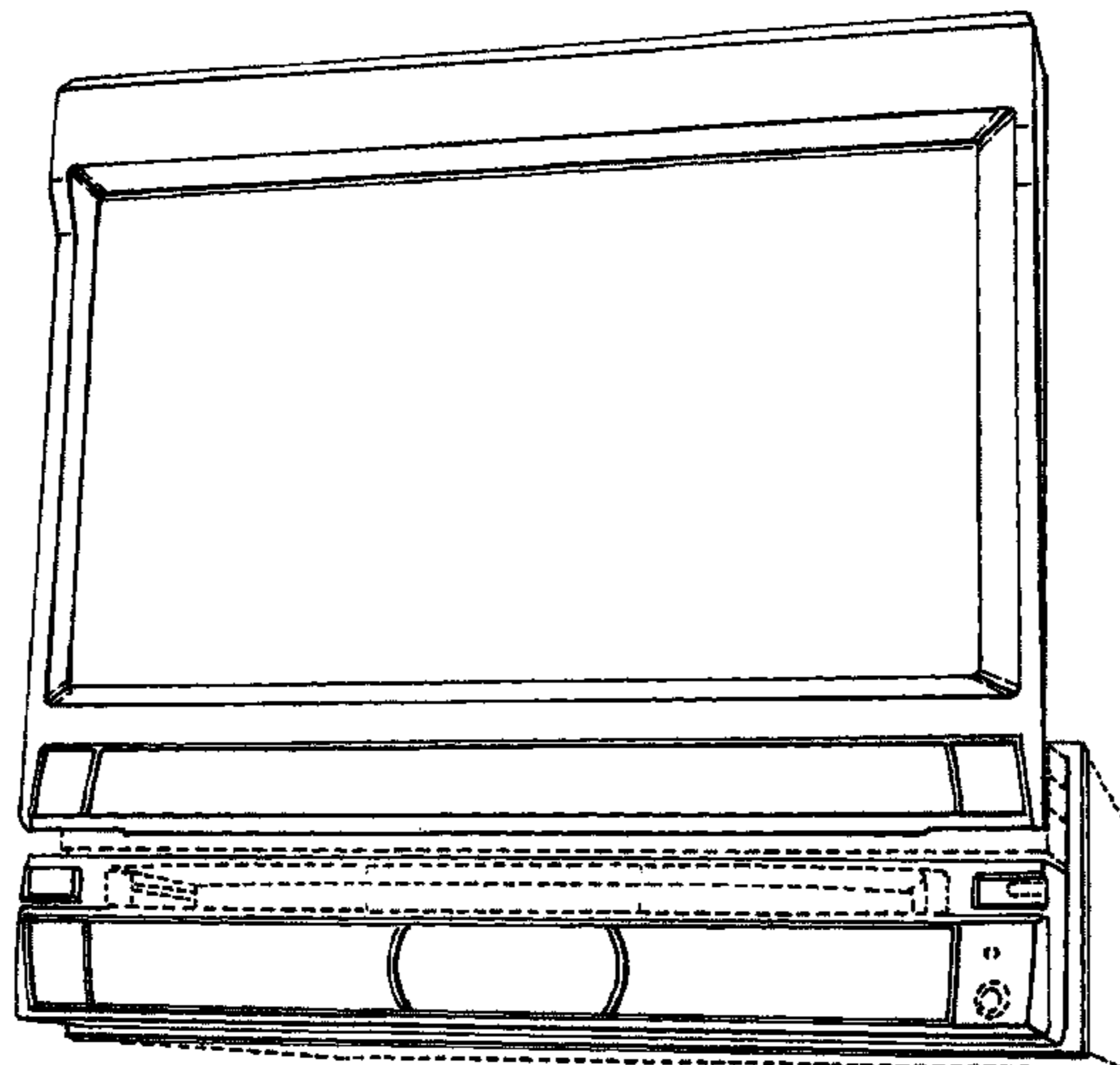

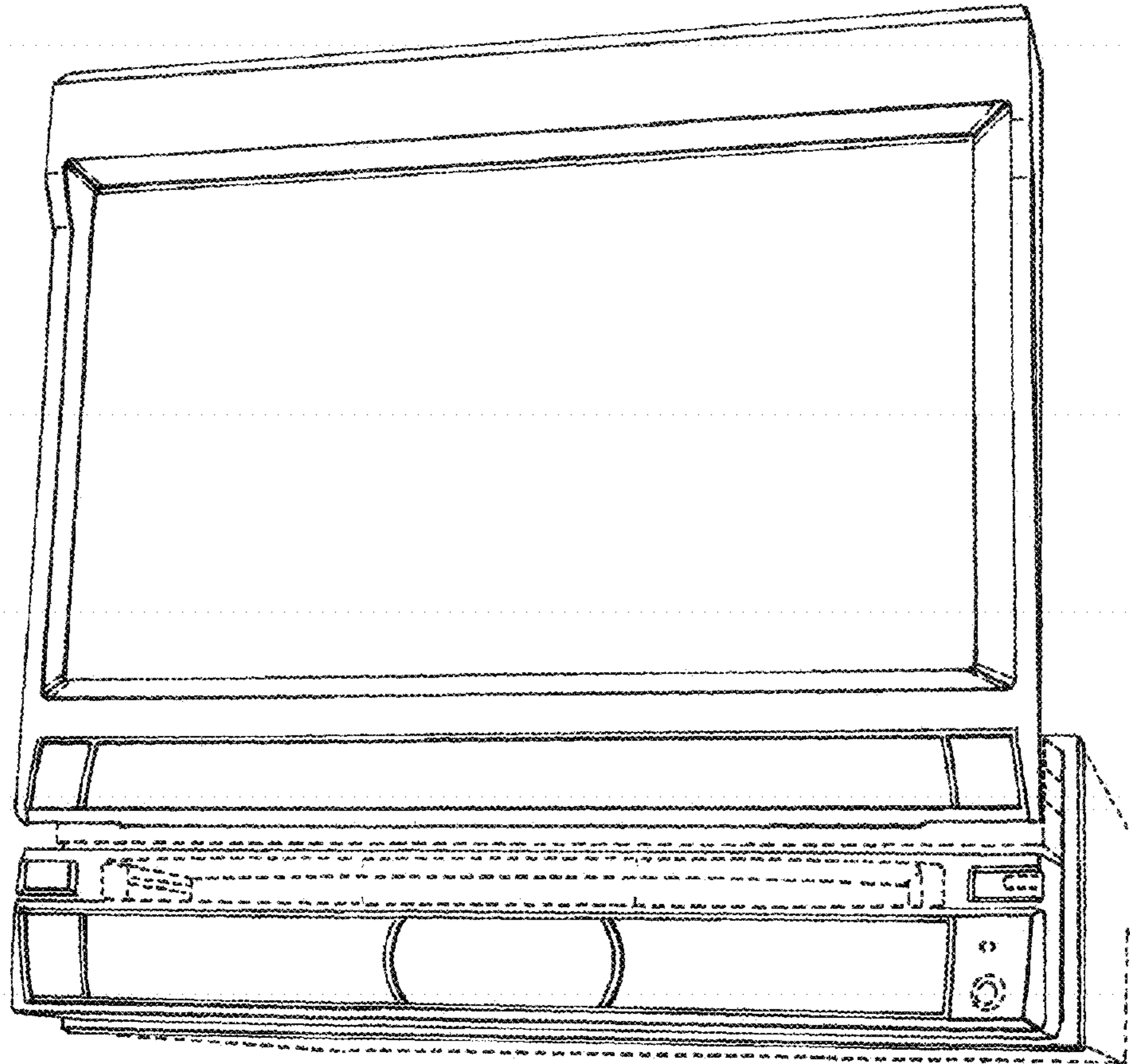

Fig. 1

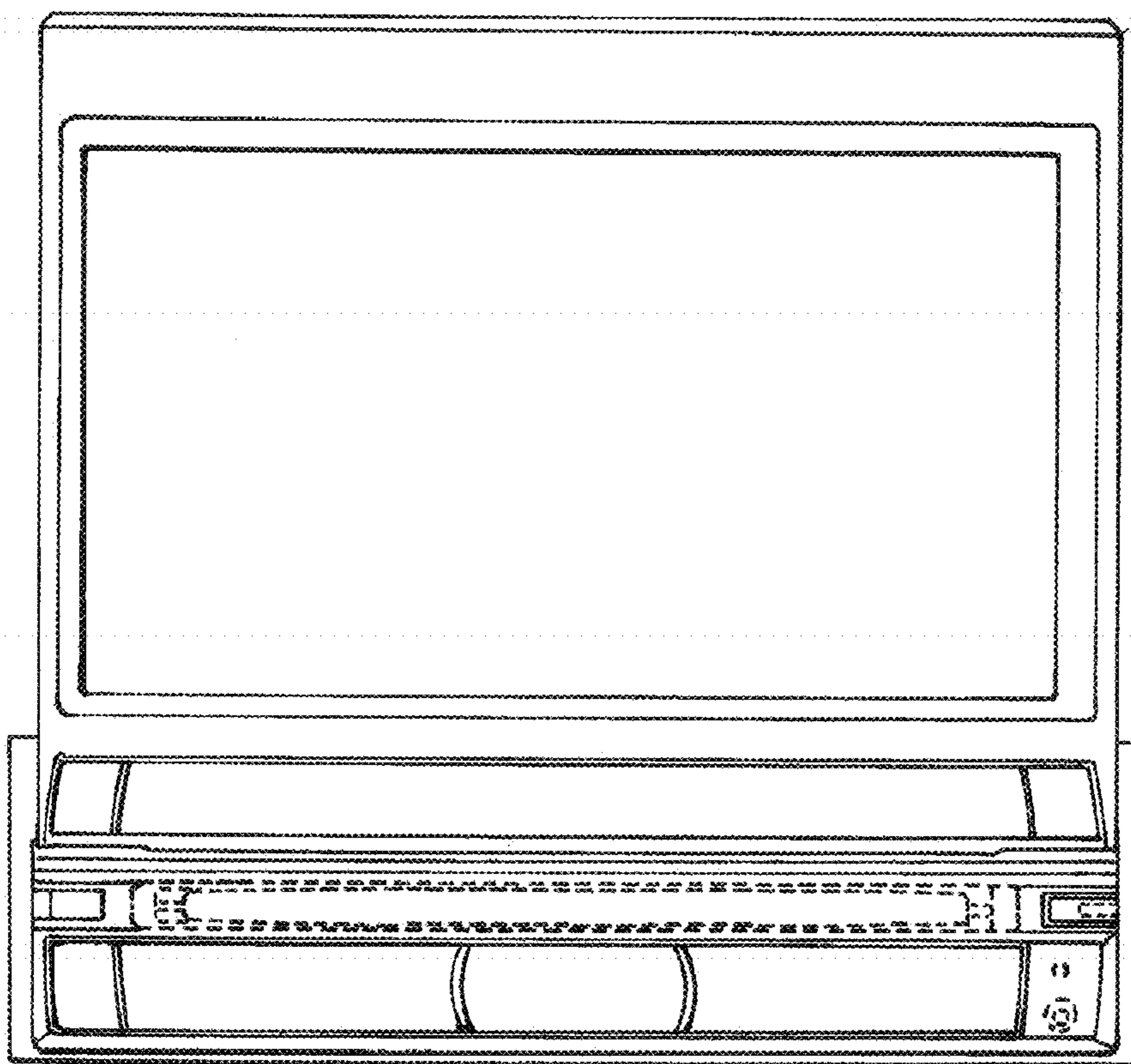

Fig. 2

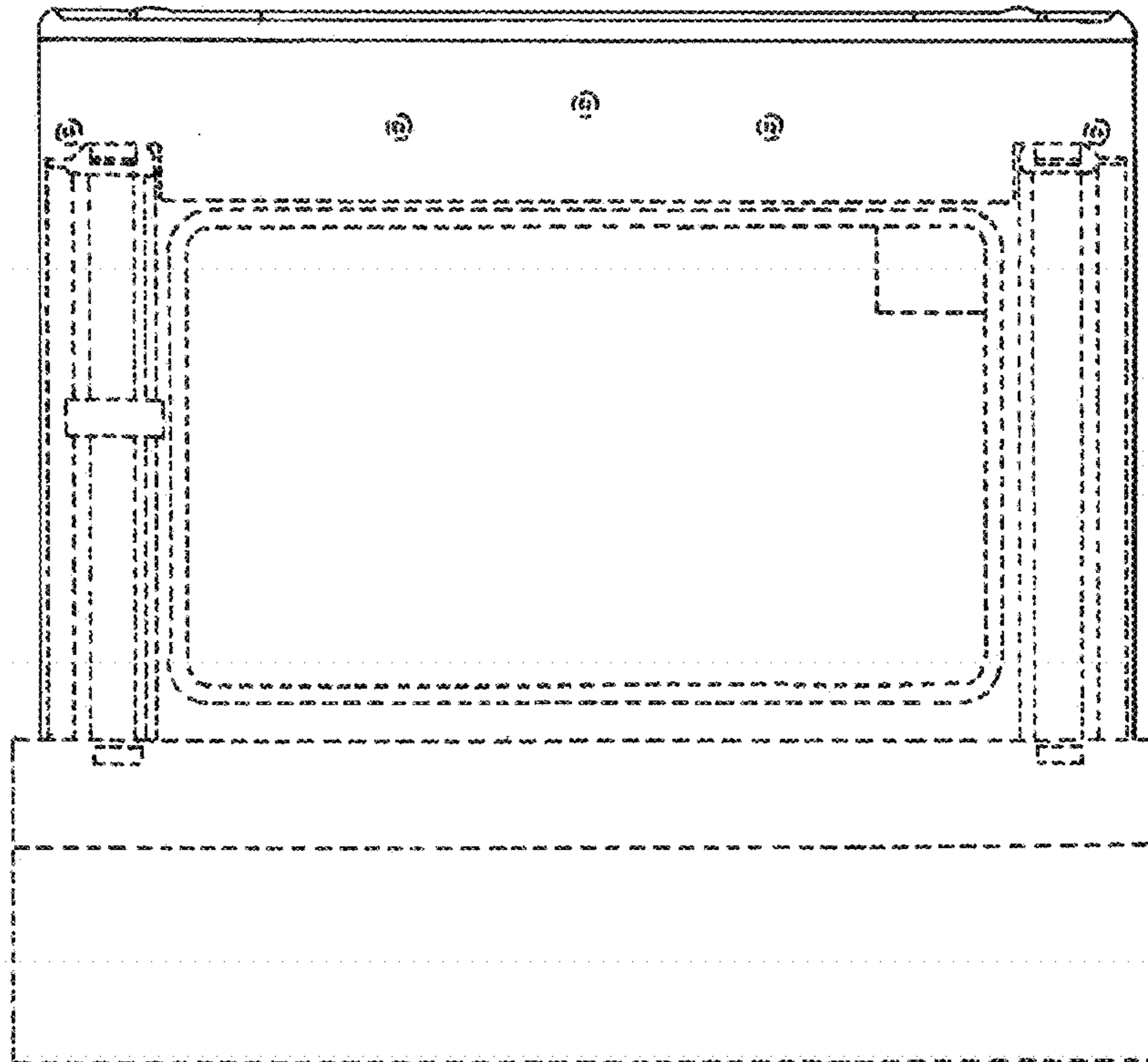

Fig. 3

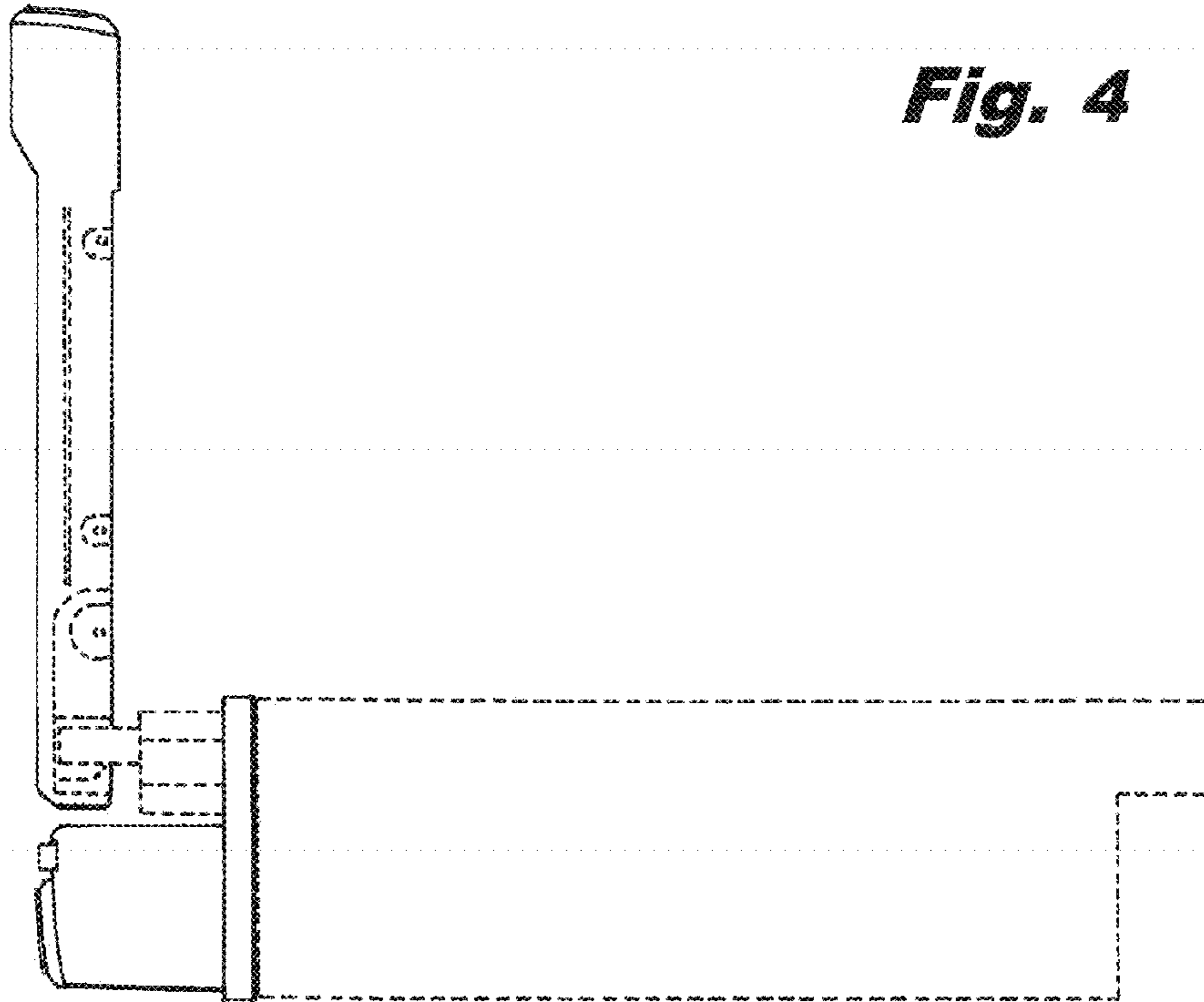
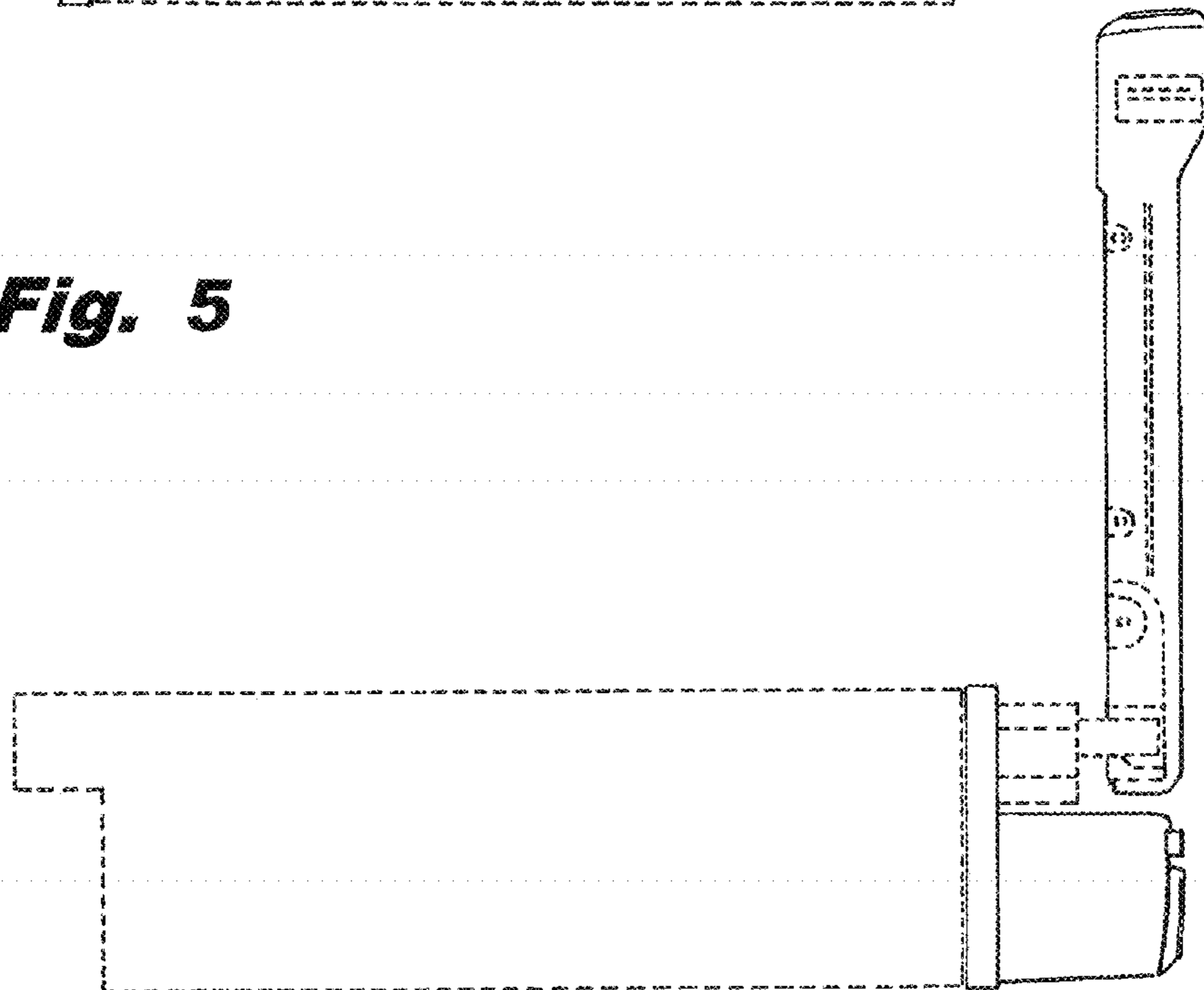

Fig. 4

Fig. 5



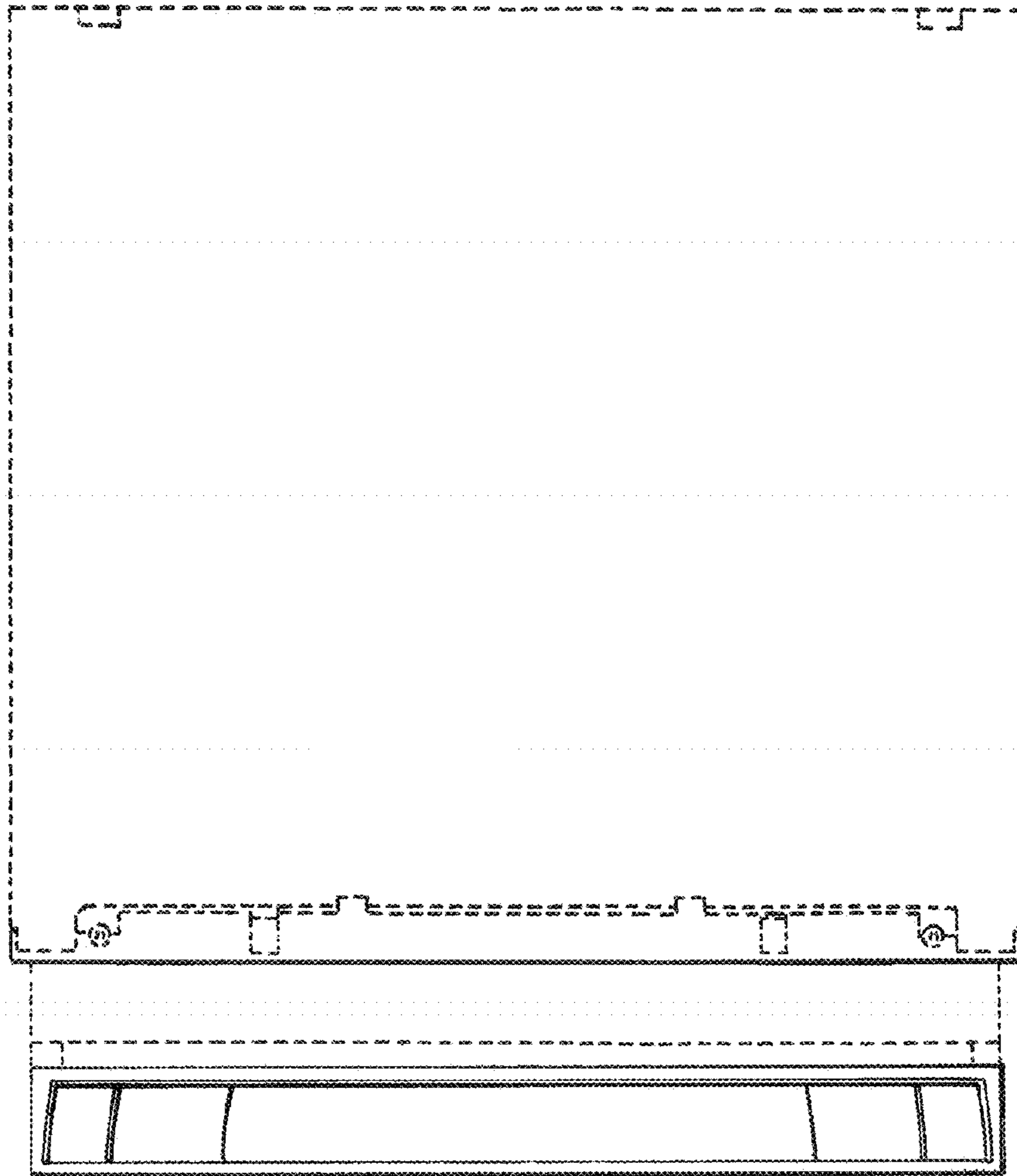

Fig. 6

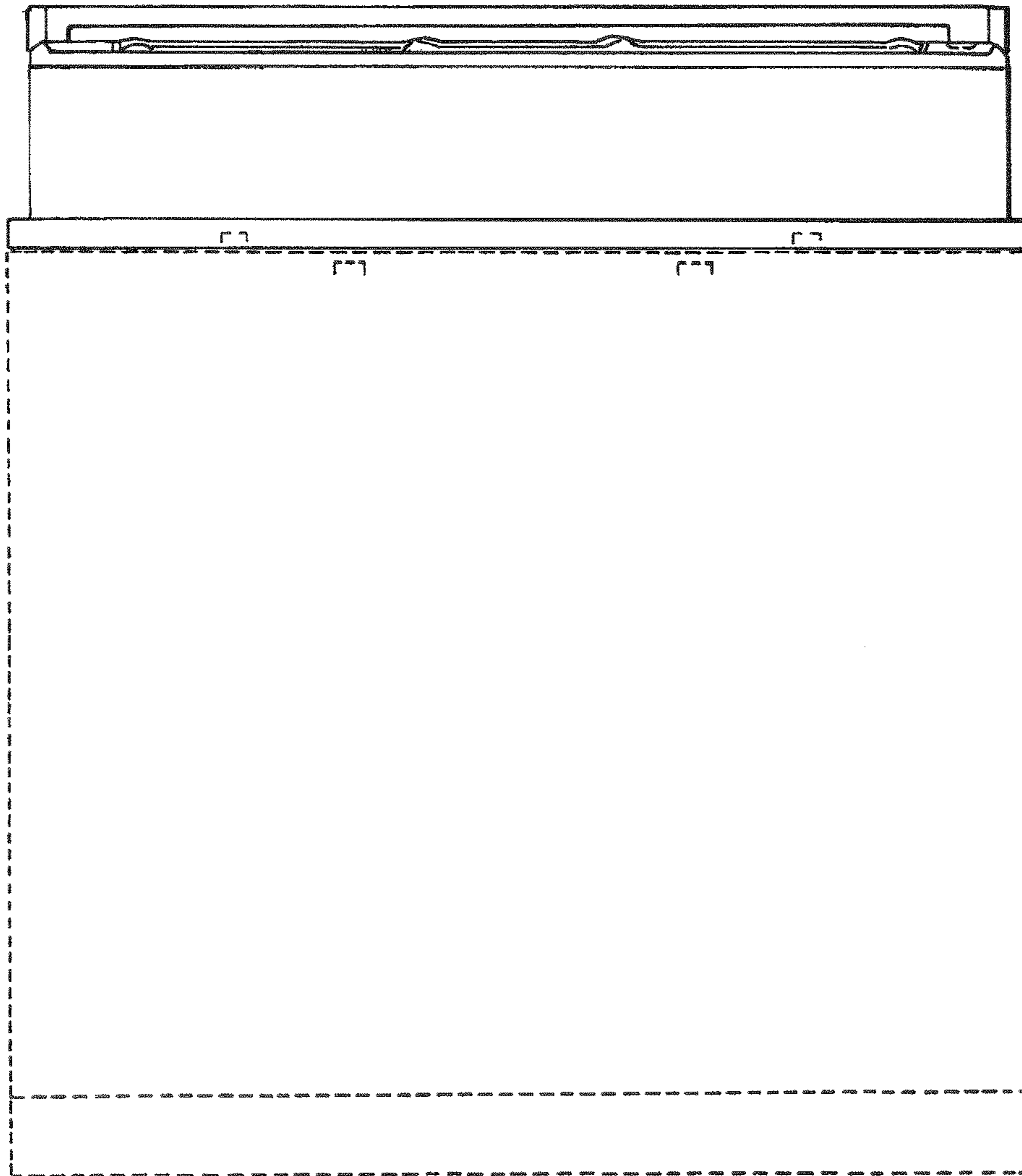

Fig. 7