



US00D680100S

(12) **United States Design Patent**
Matsumura

(10) **Patent No.:** **US D680,100 S**
(45) **Date of Patent:** **** Apr. 16, 2013**

(54) **SPEAKER FOR AUTOMOBILE**
(75) Inventor: **Takashi Matsumura**, Kawasaki (JP)
(73) Assignee: **Pioneer Corporation**, Kawasaki-shi,
Kanagawa (JP)

D593,542 S * 6/2009 Kurihara D14/216
D596,620 S * 7/2009 Ichikawa et al. D14/216
D608,345 S * 1/2010 Oishi et al. D14/216
D608,764 S * 1/2010 Oishi et al. D14/216
D635,551 S * 4/2011 Wada D14/216
D635,553 S * 4/2011 Yagihashi et al. D14/216

(**) Term: **14 Years**
(21) Appl. No.: **29/393,096**
(22) Filed: **May 31, 2011**

FOREIGN PATENT DOCUMENTS

JP 1302641 6/2007
JP 1318733 1/2008
JP 1329079 5/2008
JP 1329109 5/2008
JP 1380923 2/2010

* cited by examiner

(30) **Foreign Application Priority Data**
Dec. 2, 2010 (JP) D2010-028802
(51) **LOC (9) Cl.** **14-01**
(52) **U.S. Cl.**
USPC **D14/216; D14/204**
(58) **Field of Classification Search** D14/204,
D14/209-216, 219, 220; 181/143, 144, 147,
181/148, 150, 151, 198, 199, 153; 381/330-302,
381/306, 333, 345, 361-364, 386-388, 332,
381/336

Primary Examiner — Prabhakar Deshmukh
(74) *Attorney, Agent, or Firm* — Drinker Biddle & Reath
LLP

See application file for complete search history.

(57) **CLAIM**
The ornamental design for a speaker for automobile, as shown
and described.

(56) **References Cited**
U.S. PATENT DOCUMENTS
1,666,303 A * 4/1928 Platt 109/21.5
4,837,839 A * 6/1989 Andrews 381/182
4,965,837 A * 10/1990 Murayama et al. 381/186
4,972,675 A * 11/1990 Kawahara et al. 60/488
D422,206 S * 4/2000 Clark D8/400
D542,779 S * 5/2007 Pantaleone D14/216
D579,916 S * 11/2008 Ichikawa D14/216

DESCRIPTION

FIG. 1 is a perspective view of the front, bottom and right side
of a speaker for automobile showing my new design;
FIG. 2 is a right side view thereof;
FIG. 3 is a left side view thereof;
FIG. 4 is a front view thereof;
FIG. 5 is a front view showing a state without the grill thereof;
FIG. 6 is a bottom view thereof;
FIG. 7 is a top plan view thereof; and,
FIG. 8 is a rear view thereof.

1 Claim, 5 Drawing Sheets

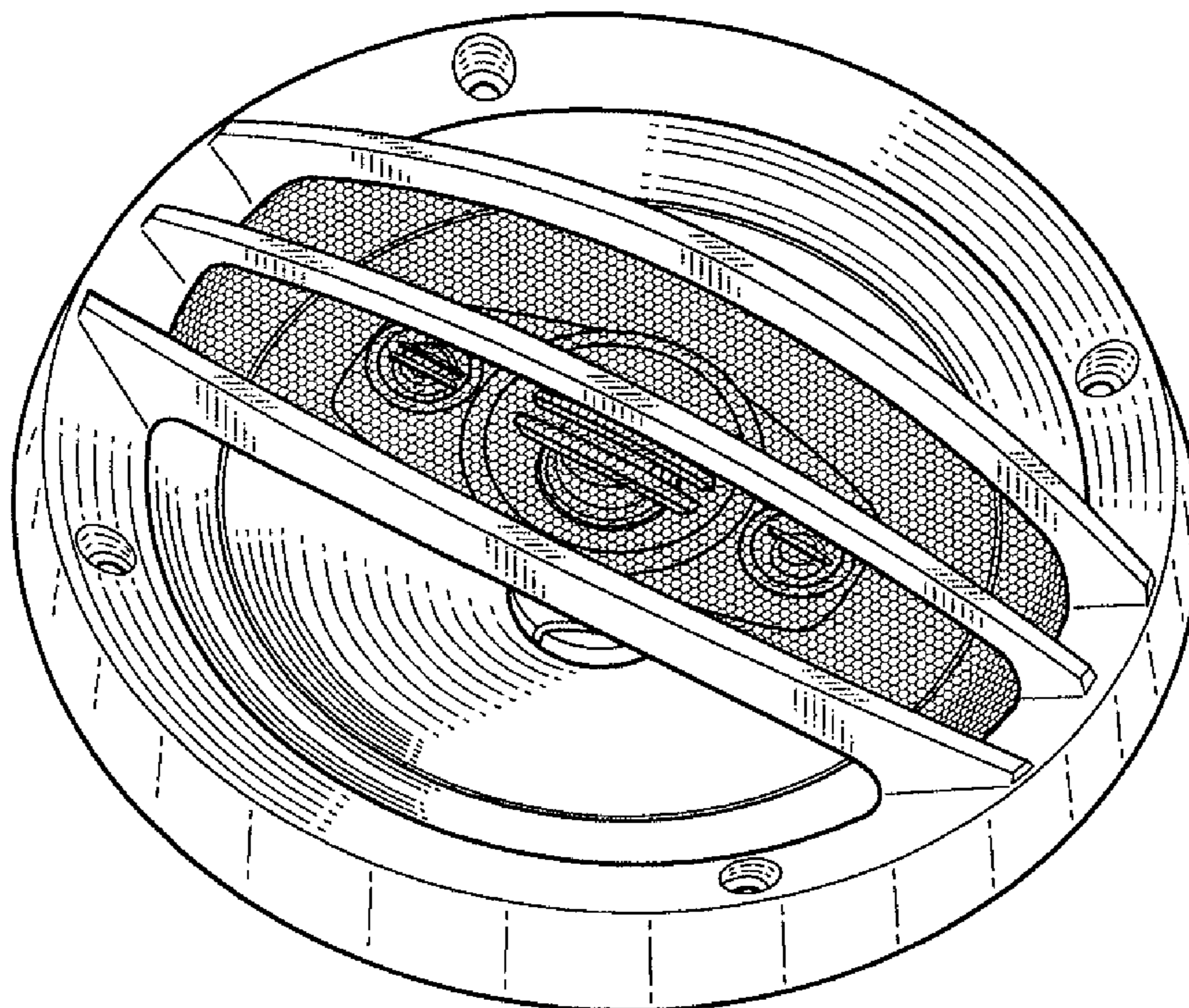

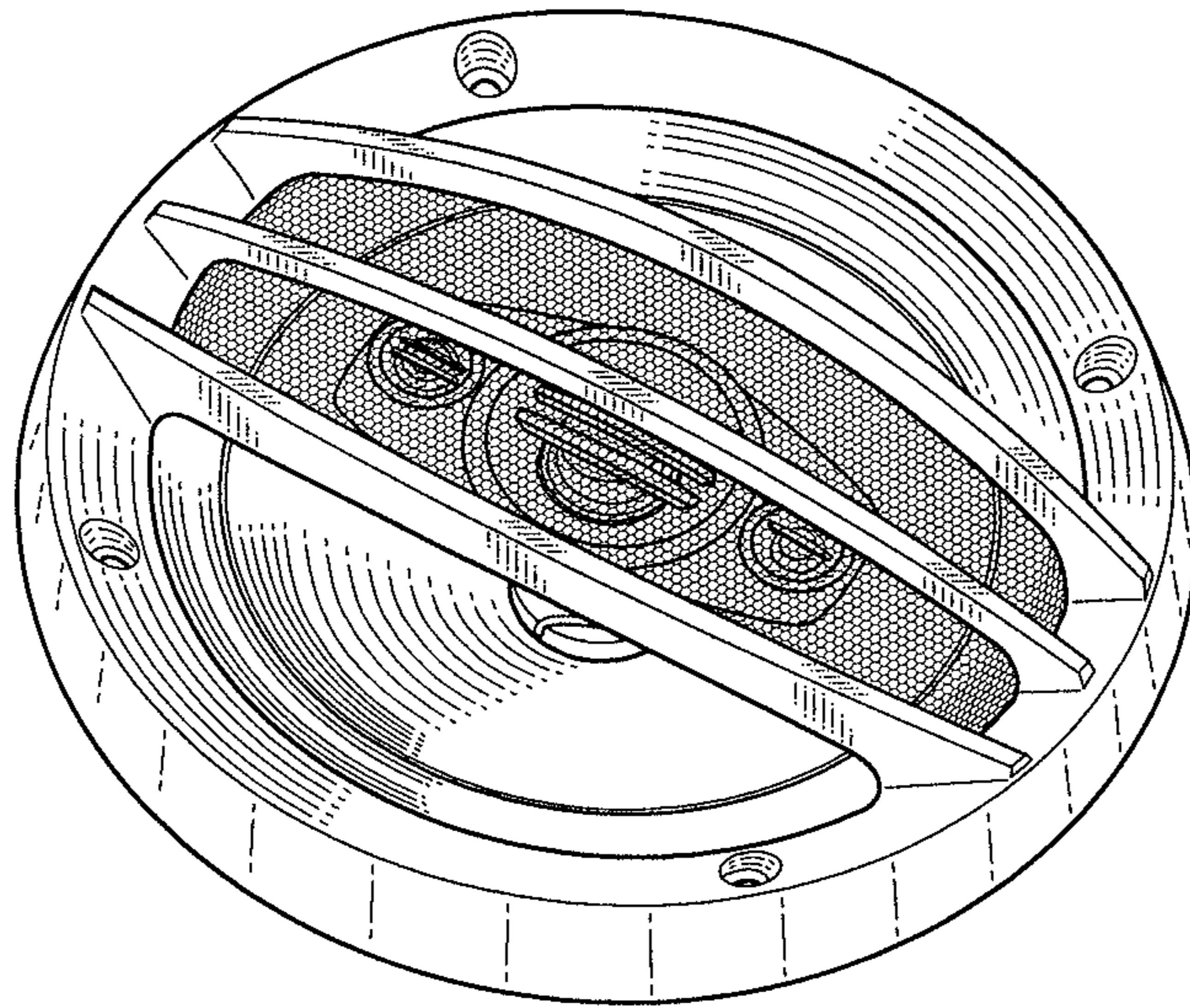

FIG. 1

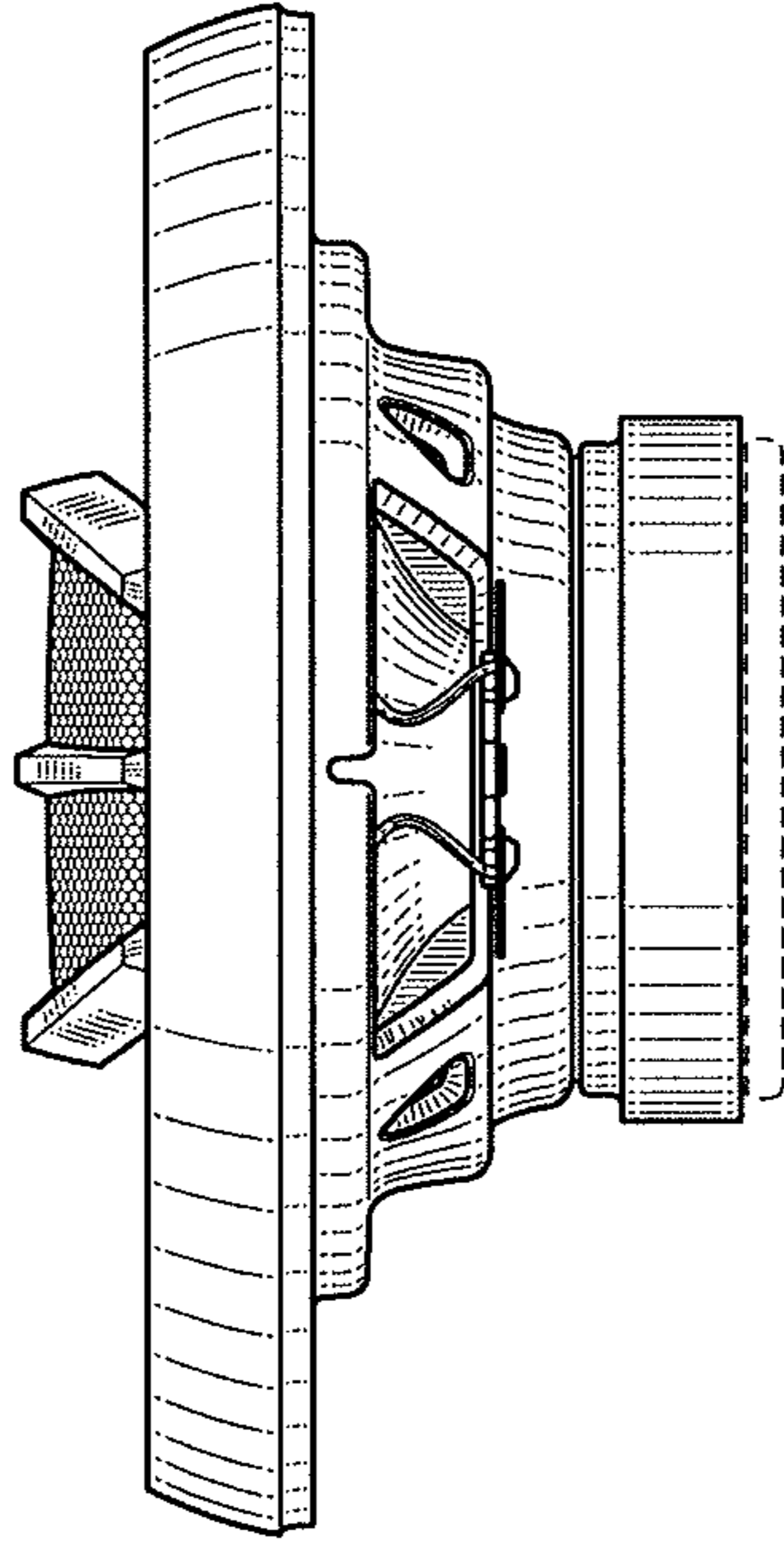

FIG. 2

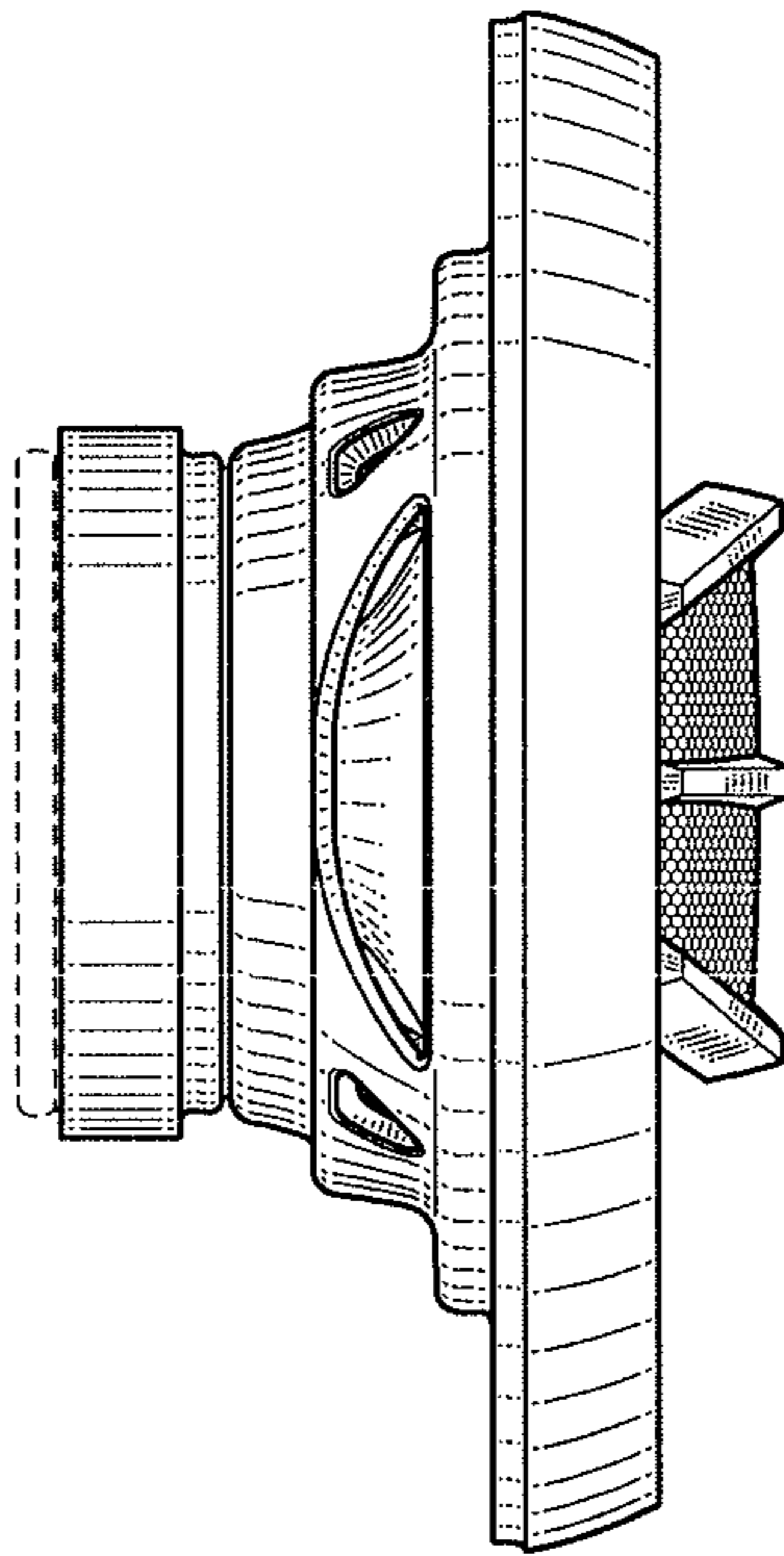

FIG. 3

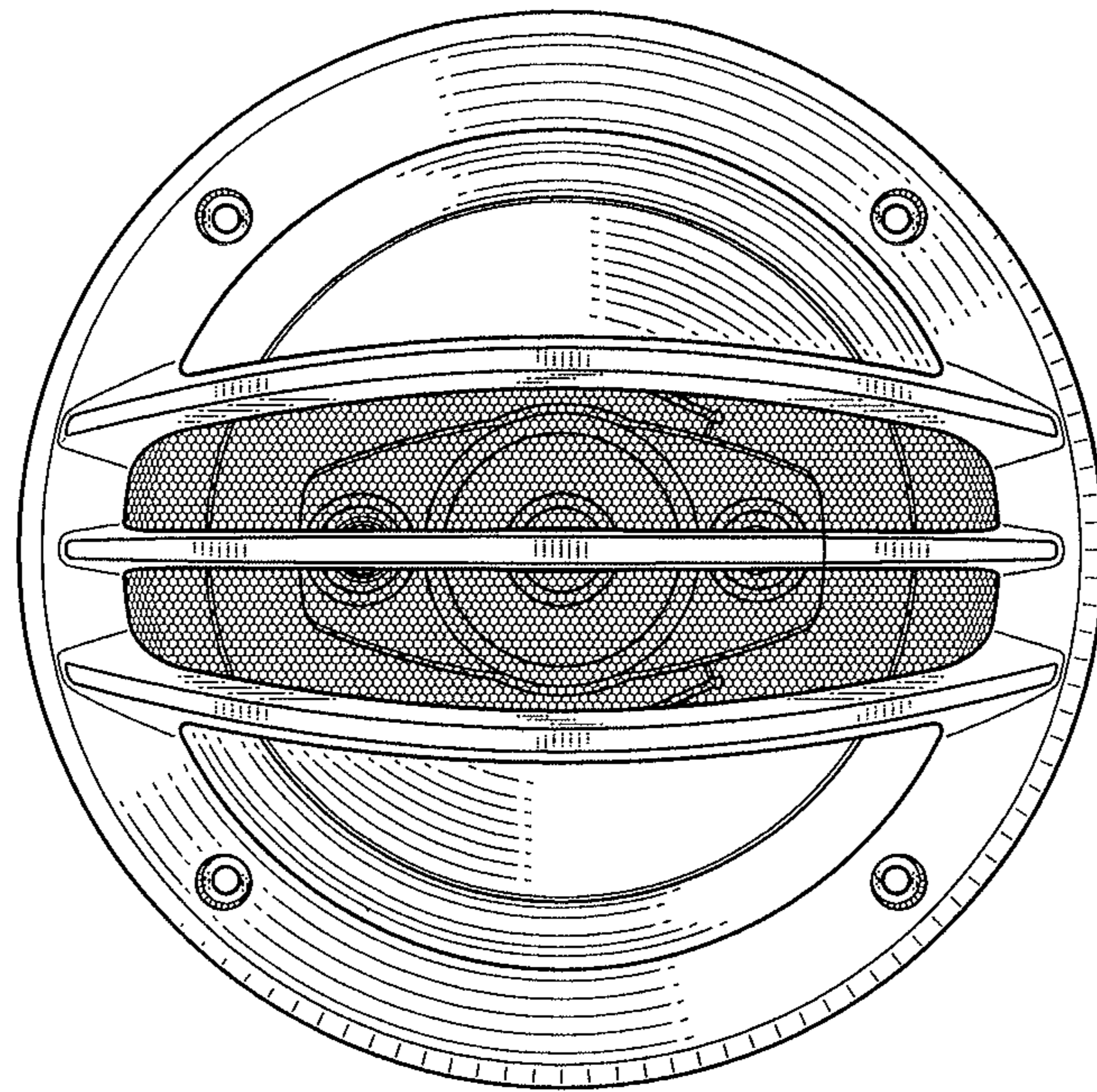

FIG. 4

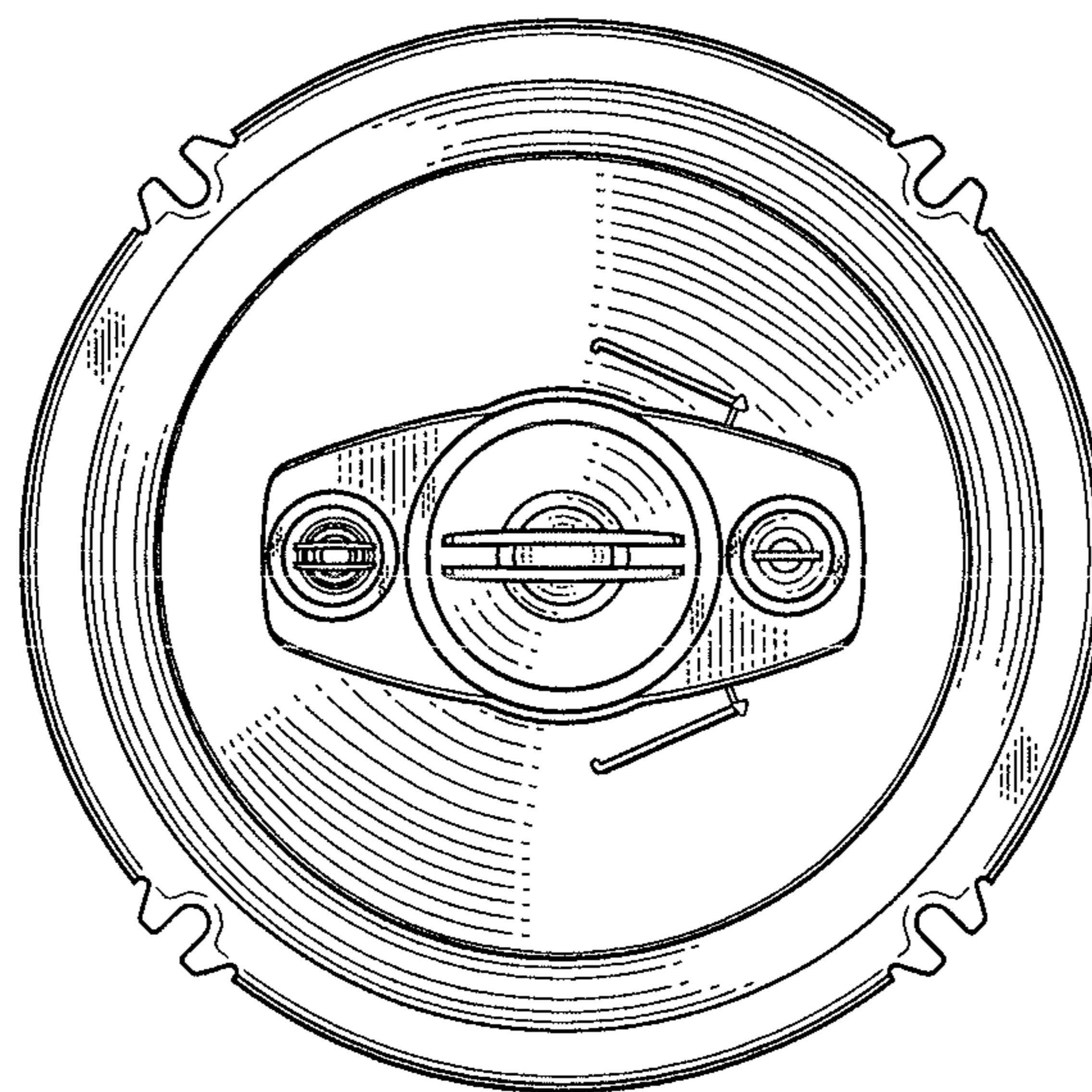

FIG. 5

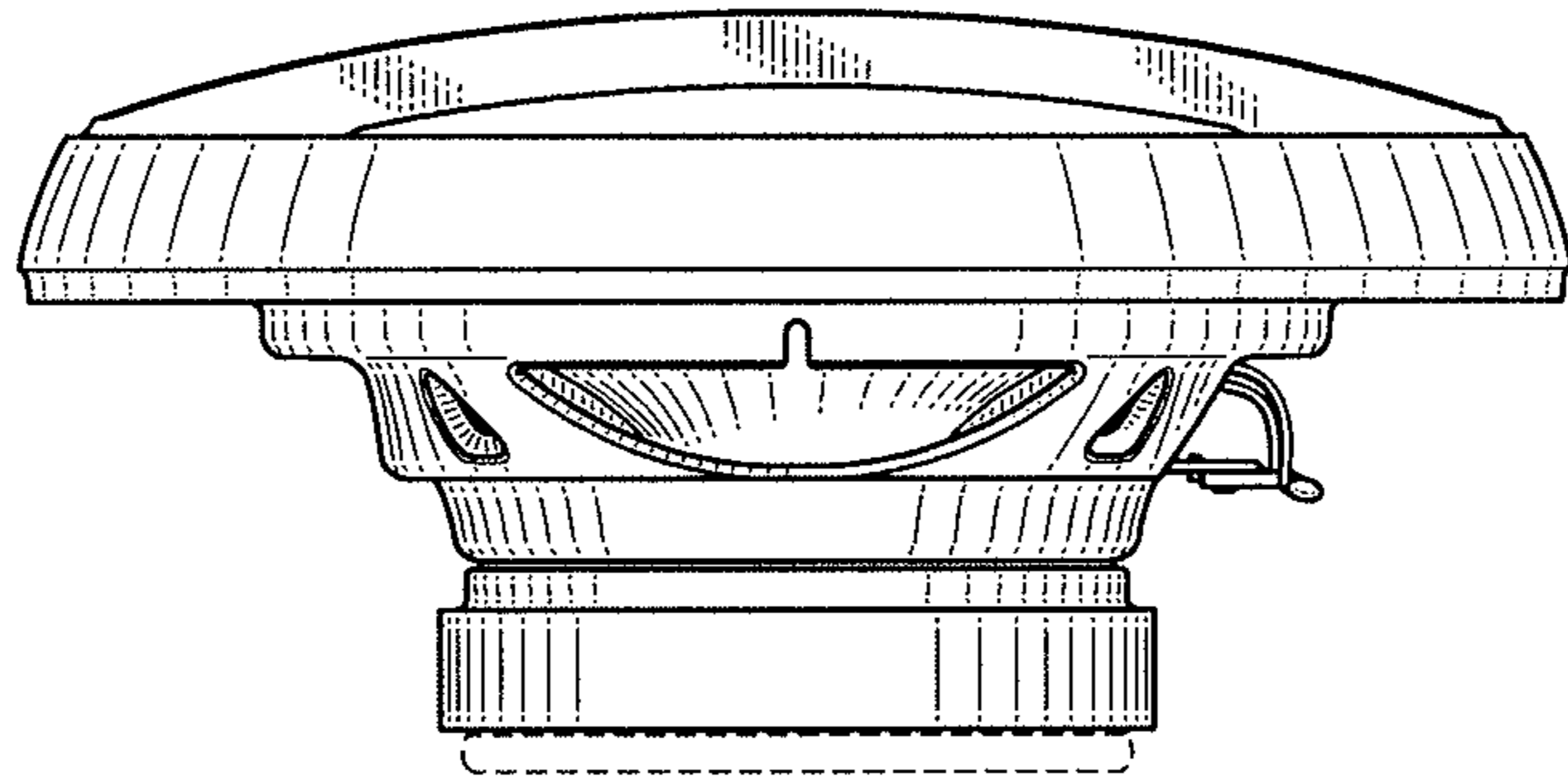

FIG. 6

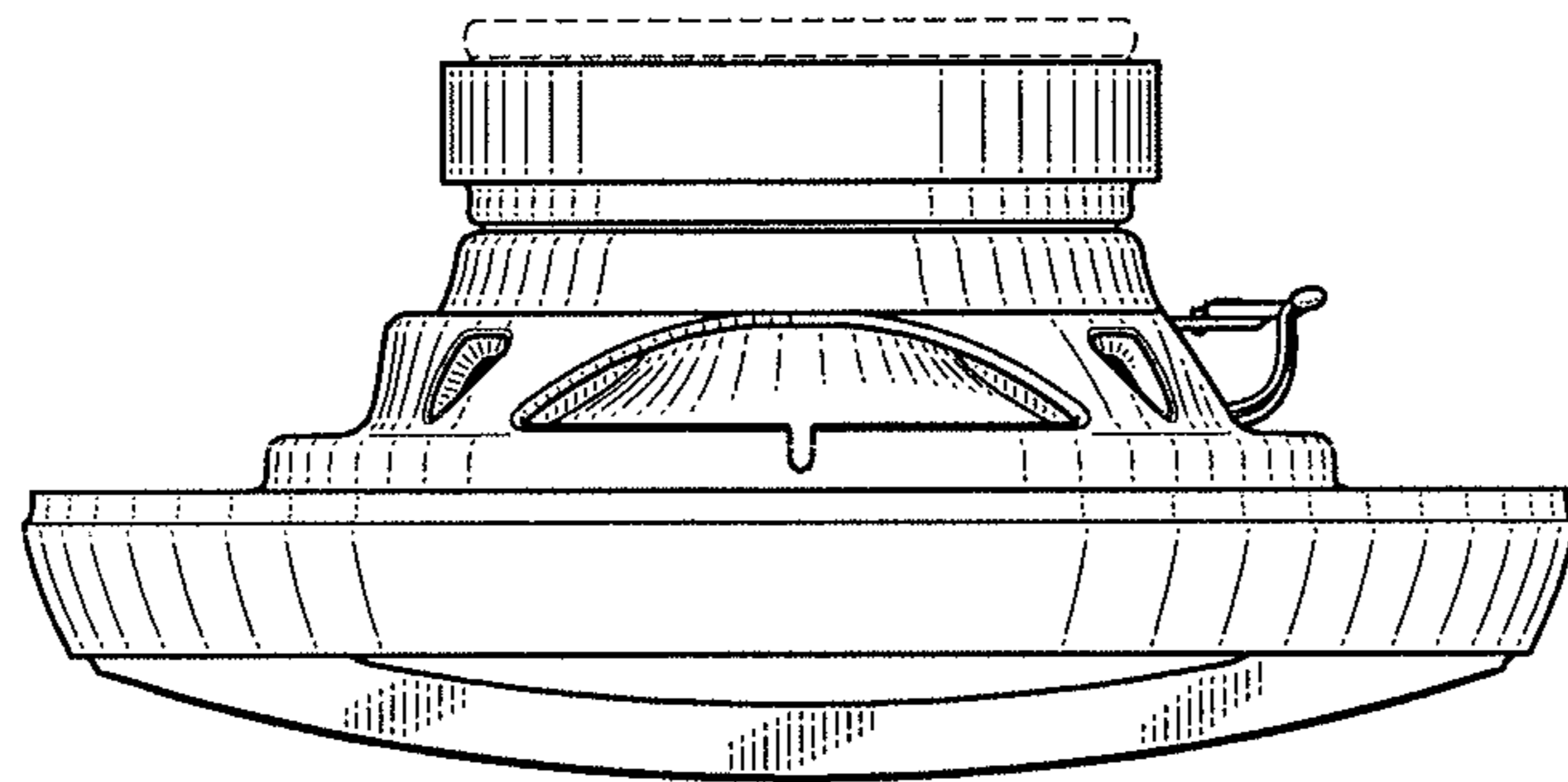

FIG. 7

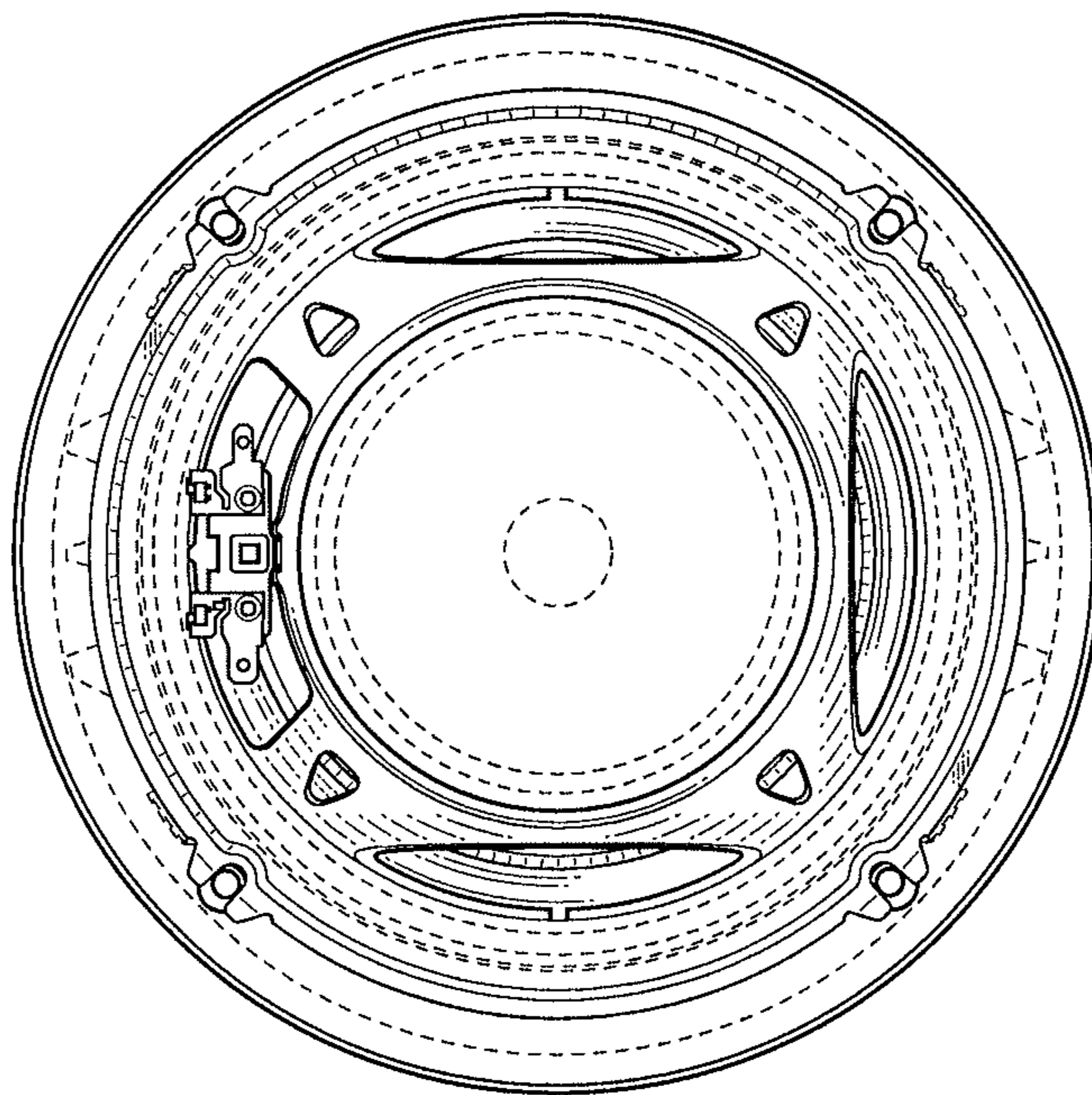

FIG. 8