

US00D680035S

(12) **United States Design Patent**
Fetherston et al.

(10) **Patent No.:** **US D680,035 S**

(45) **Date of Patent:** **** Apr. 16, 2013**

(54) **FRONT PORTION OF A VEHICLE, TOY,
AND/OR REPLICAS THEREOF**

(74) *Attorney, Agent, or Firm* — Crowell & Moring LLP

(75) Inventors: **Mark Fetherston**, Stuttgart (DE); **Klaus Frenzel**, Stuttgart (DE); **Hans-Dieter Futschik**, Stuttgart (DE); **Gorden Wagener**, Stuttgart (DE)

(57) **CLAIM**
The ornamental design for a front portion of a vehicle, toy, and/or replicas thereof, as shown and described.

(73) Assignee: **Daimler AG**, Stuttgart (DE)

DESCRIPTION

(**) Term: **14 Years**

(21) Appl. No.: **29/423,330**

(22) Filed: **May 31, 2012**

(30) **Foreign Application Priority Data**

Dec. 1, 2011 (EM) 001304620-0002

(51) **LOC (9) Cl.** **12-16**

(52) **U.S. Cl.**
USPC **D12/164**

(58) **Field of Classification Search** D12/86,
D12/90-92, 162; D21/424, 433, 434; 296/181.1,
296/181.5

See application file for complete search history.

(56) **References Cited**

U.S. PATENT DOCUMENTS

D596,078 S * 7/2009 Pfeiffer et al. D12/92
D634,678 S * 3/2011 Futschik et al. D12/164
D635,898 S * 4/2011 Baur et al. D12/164

* cited by examiner

This application contains subject matter related to the following co-pending U.S. design patent applications: Application Ser. No. 29/423,325, filed herewith and entitled "Vehicle, Toy, and/or Replicas Thereof"; Application Ser. No. 29/423,326, filed herewith and entitled "Front Portion of a Vehicle, Toy, and/or Replicas Thereof"; Application Ser. No. 29/423,329, filed herewith and entitled "Vehicle, Toy, and/or Replicas Thereof"; Application Ser. No. 29/423,332, filed herewith and entitled "Front Bumper for a Vehicle"; Application Ser. No. 29/423,334, filed herewith and entitled "Radiator Grill for a Vehicle"; Application Ser. No. 29/423,335, filed herewith and entitled "Radiator Grill for a Vehicle"; Application Ser. No. 29/423,337, filed herewith and entitled "Headlight for a Vehicle"; and Application Ser. No. 29/423,338, filed herewith and entitled "Headlight for a Vehicle".

FIG. 1 is a left, front perspective view of a front portion of a vehicle, toy, and/or replicas thereof according to our design; FIG. 2 is a front view thereof; FIG. 3 is a left side view thereof; FIG. 4 is a right side view thereof; and, FIG. 5 is a top view thereof.
The broken lines are for illustrative purposes only and form no part of the claimed design.

Primary Examiner — Melody Brown

1 Claim, 4 Drawing Sheets

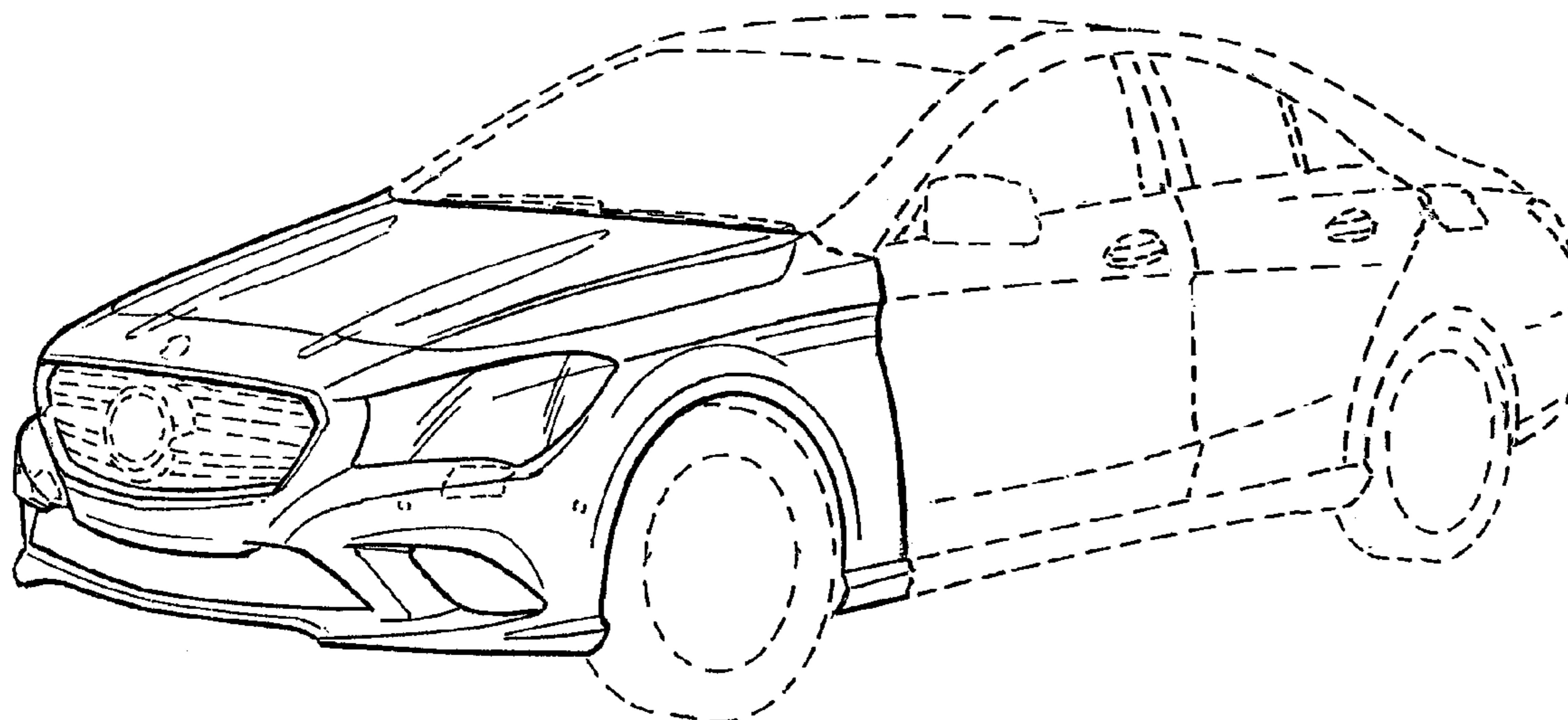

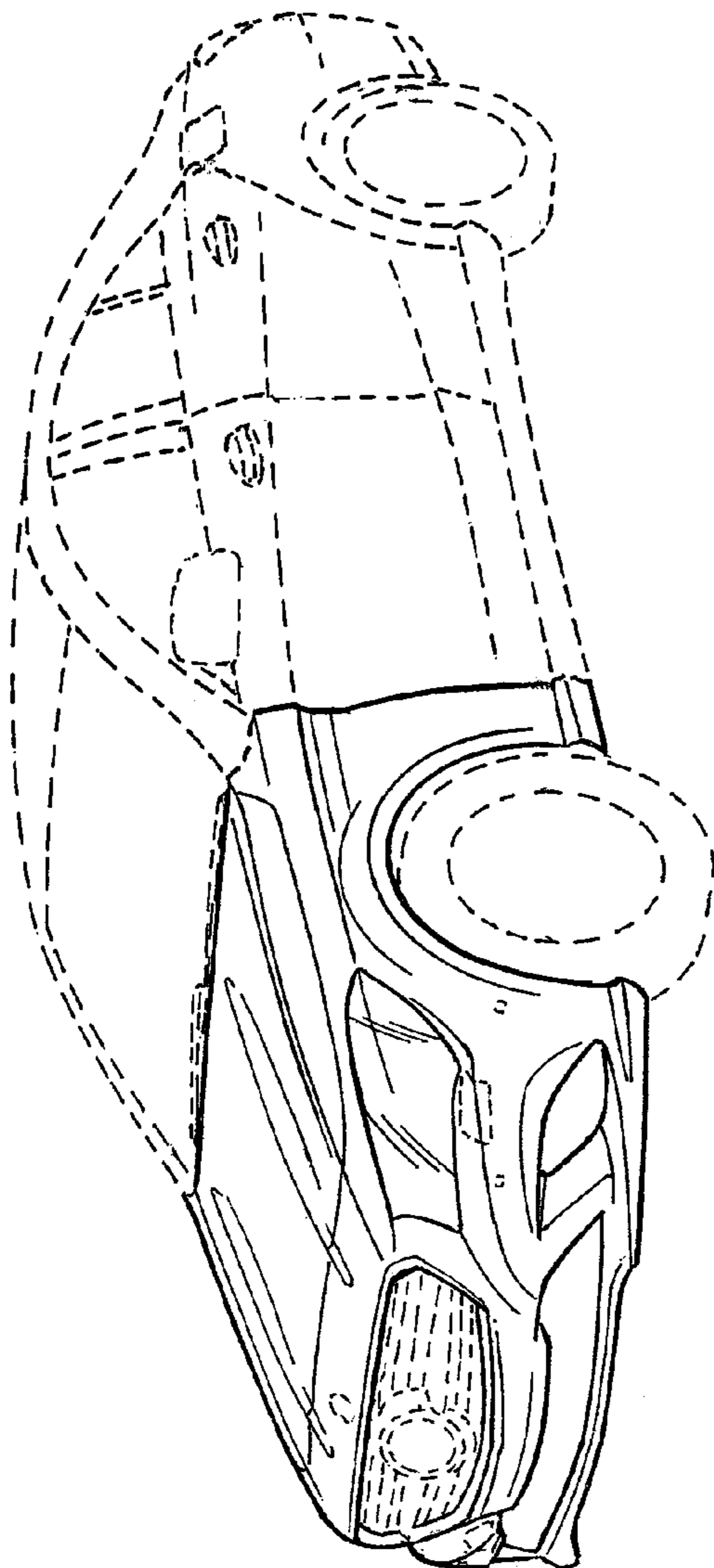

FIG. 1

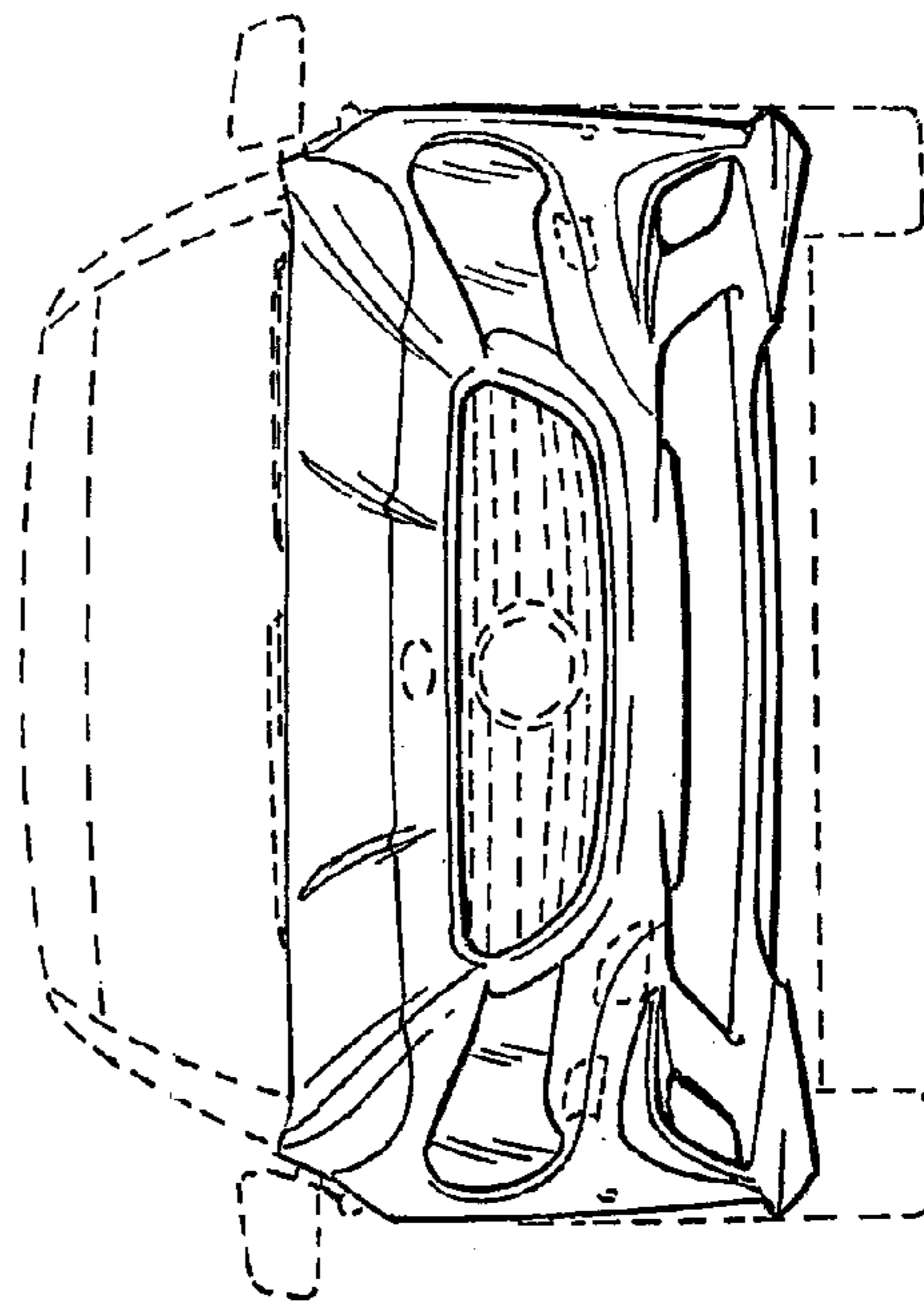

FIG. 2

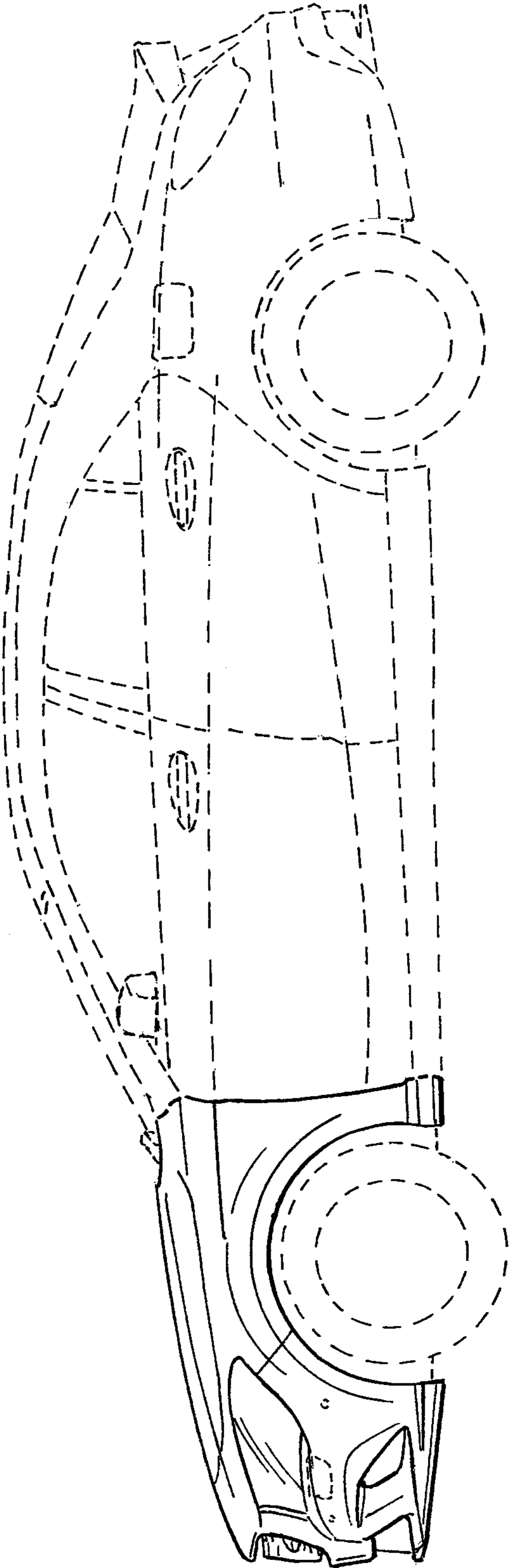

FIG. 3

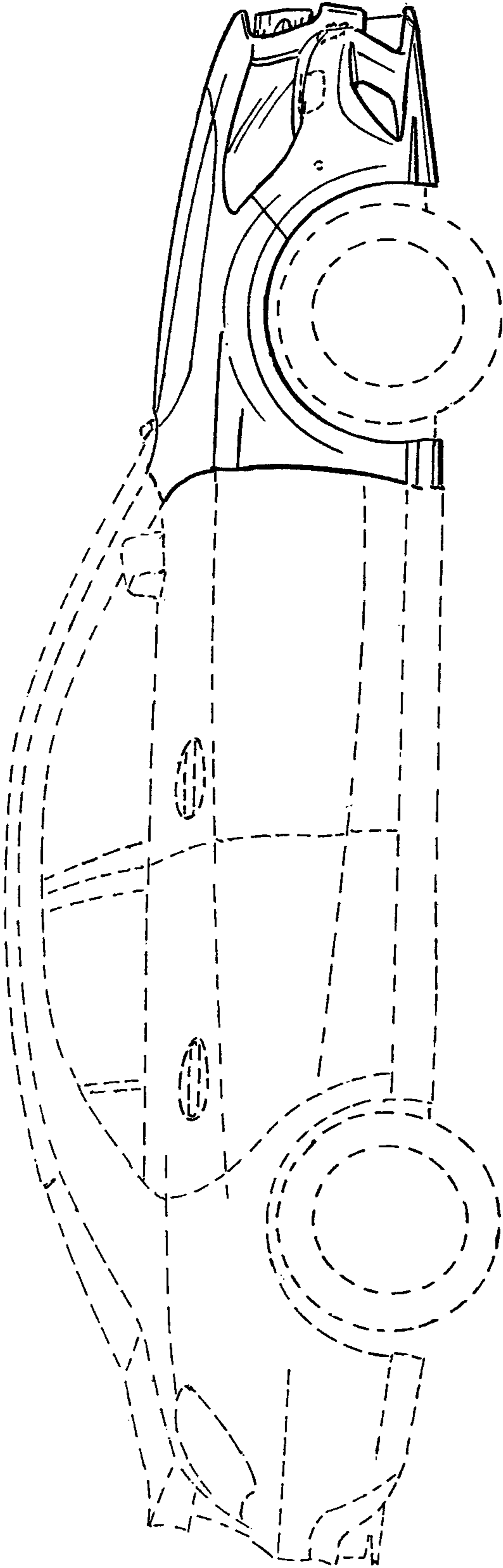

FIG. 4

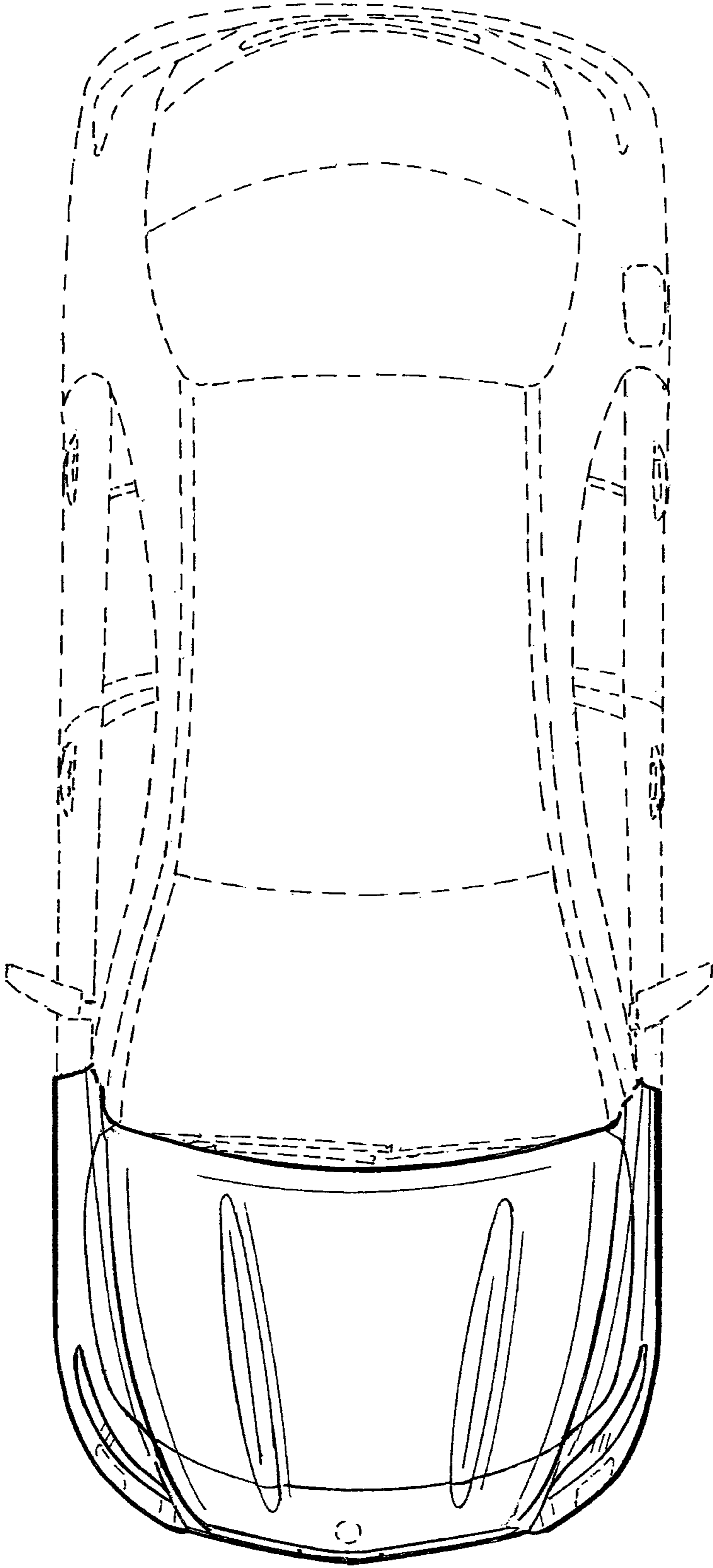

FIG. 5