



US00D679868S

(12) **United States Design Patent**
Blomberg et al.

(10) **Patent No.:** **US D679,868 S**

(45) **Date of Patent:** **** Apr. 9, 2013**

(54) **JET BRIDGE SHUTTLE**

OTHER PUBLICATIONS

(75) Inventors: **John P. Blomberg**, Red Wing, MN (US);
Scott C. Casebolt, St. Paul Park, MN
(US); **Matthew J. Blackford**, Hastings,
MN (US)

Kingspan Safetraxx Specification. Kingspan Saferidge Website.
[online] [retrieved on Jun. 25, 2010] Retrieved from the internet:
<URL: http://saferidge.com/safetraxx_spec.htm>.

Uniline Safety Systems, MultiSafe UniRail. [online] [retrieved Jun.
30, 2010] Retrieved online at <URL: <http://www.unilinesafety.com/Systems/MultiSafeUniRail/>>.

(73) Assignee: **D B Industries, Inc.**, Red Wing, MN
(US)

* cited by examiner

(**) Term: **14 Years**

Primary Examiner — Raphael Barkai
Assistant Examiner — Randall Gholson

(21) Appl. No.: **29/386,061**

(74) *Attorney, Agent, or Firm* — IPLM Group, P.A.

(22) Filed: **Feb. 24, 2011**

(51) **LOC (9) Cl.** **29-02**

(52) **U.S. Cl.** **D29/122**

(58) **Field of Classification Search** D29/122,
D29/124; D8/349, 333, 330, 358, 360, 383,
D8/499; 192/223.1; 242/353.5, 383, 383.4;
29/434; 182/239, 237, 236, 231, 232; 188/82.77
See application file for complete search history.

(57) **CLAIM**

The ornamental design for a jet bridge shuttle, as shown and described.

DESCRIPTION

(56) **References Cited**

U.S. PATENT DOCUMENTS

4,195,873	A *	4/1980	Johnston	294/106
4,606,430	A *	8/1986	Roby et al.	182/3
5,156,233	A *	10/1992	Olsen et al.	182/3
5,271,481	A *	12/1993	Rich	182/3
5,297,651	A *	3/1994	Vandelinde	182/3
5,526,896	A *	6/1996	O'Rourke	182/3
5,711,397	A *	1/1998	Flora et al.	182/3
6,298,629	B1 *	10/2001	Ador	52/698
6,325,347	B1 *	12/2001	Crichton	248/228.1
6,488,118	B1 *	12/2002	Corriveau	182/36
6,520,290	B1 *	2/2003	Carter	182/36
7,926,774	B1 *	4/2011	Wilson	248/229.14
8,100,369	B2 *	1/2012	Osborn et al.	248/72

FIG. 1 is a front perspective view of a jet bridge shuttle constructed according to the principles of the present invention;

FIG. 2 is a left side view of the shuttle shown in FIG. 1;

FIG. 3 is a front view of the shuttle shown in FIG. 1;

FIG. 4 is a rear view of the shuttle shown in FIG. 1;

FIG. 5 is top view of the shuttle shown in FIG. 1; and,

FIG. 6 is bottom view of the shuttle shown in FIG. 1.

The right side is a mirror image of the left side.

The broken lines in the drawings showing portions of the jet bridge shuttle are for purposes of illustrating the portions that form no part of the claimed design.

1 Claim, 6 Drawing Sheets

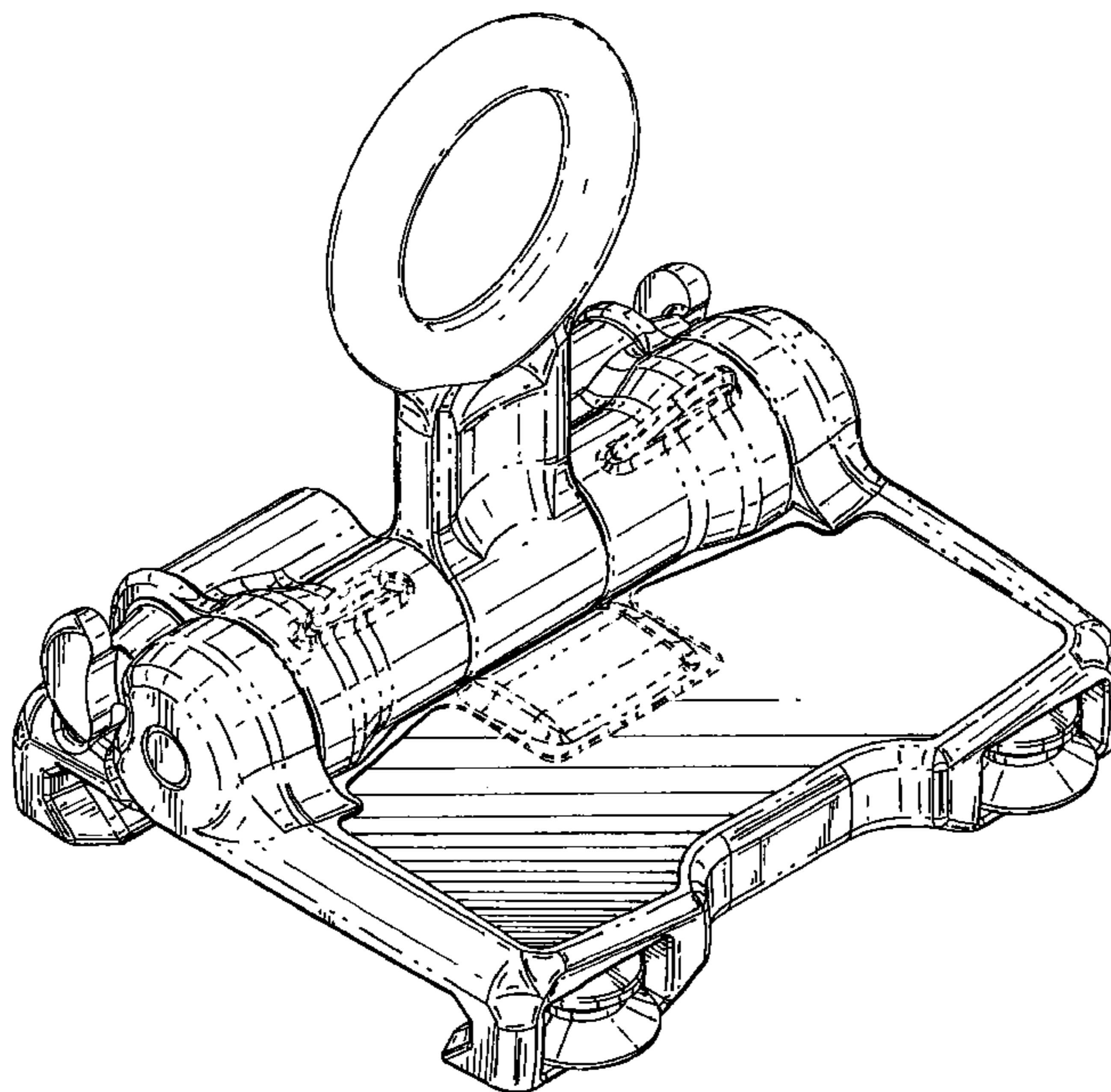
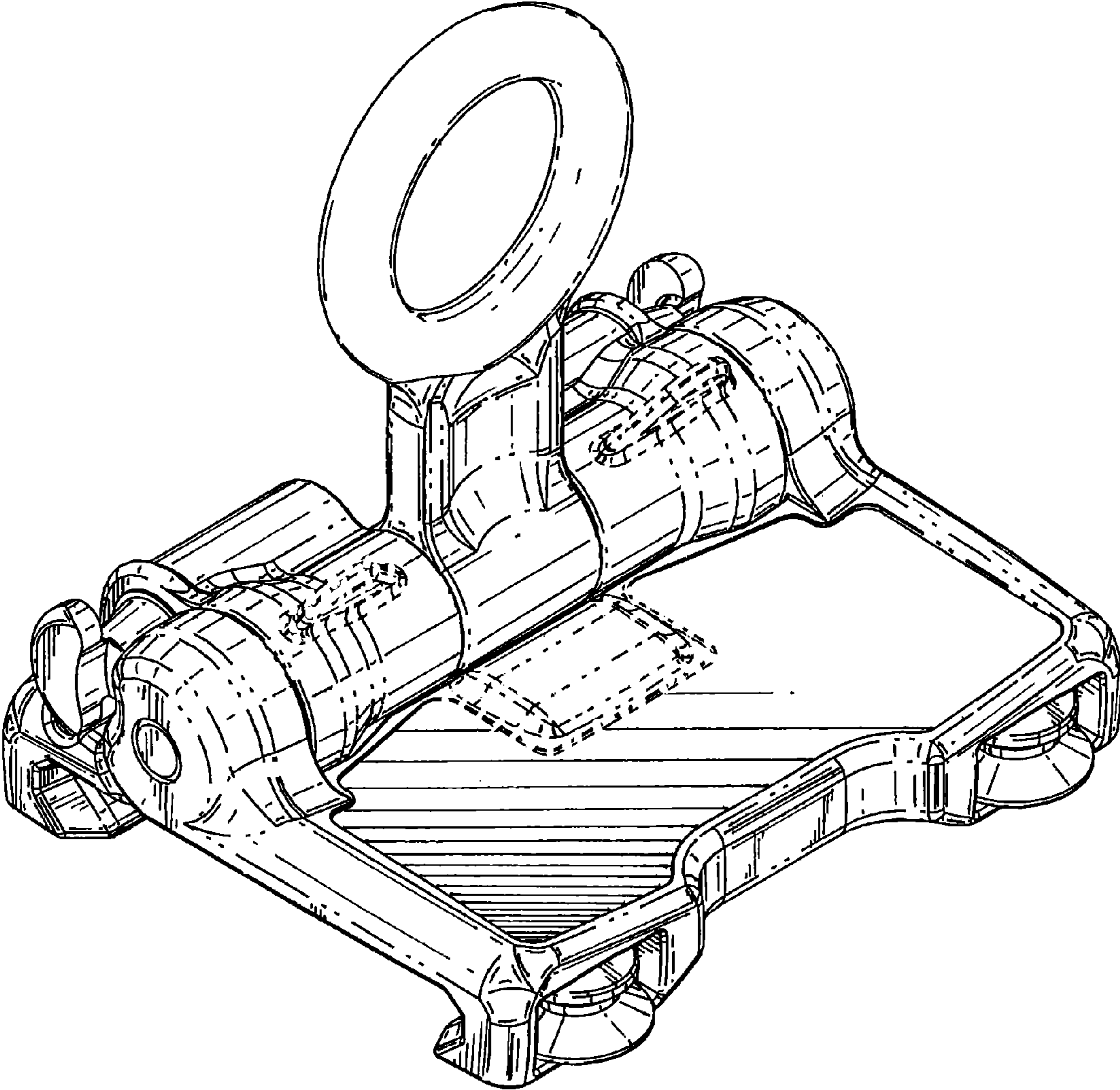

FIG. 1



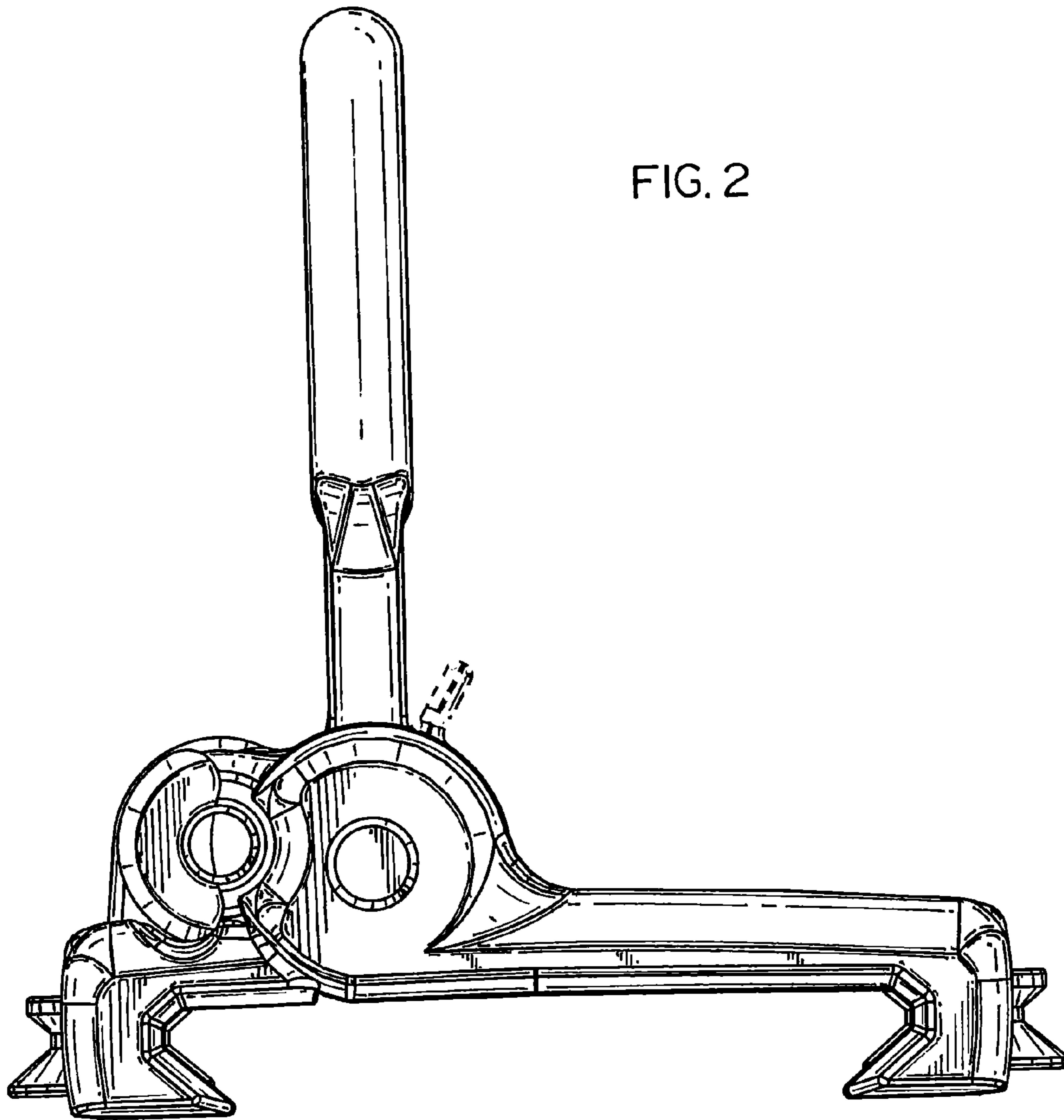

FIG. 2

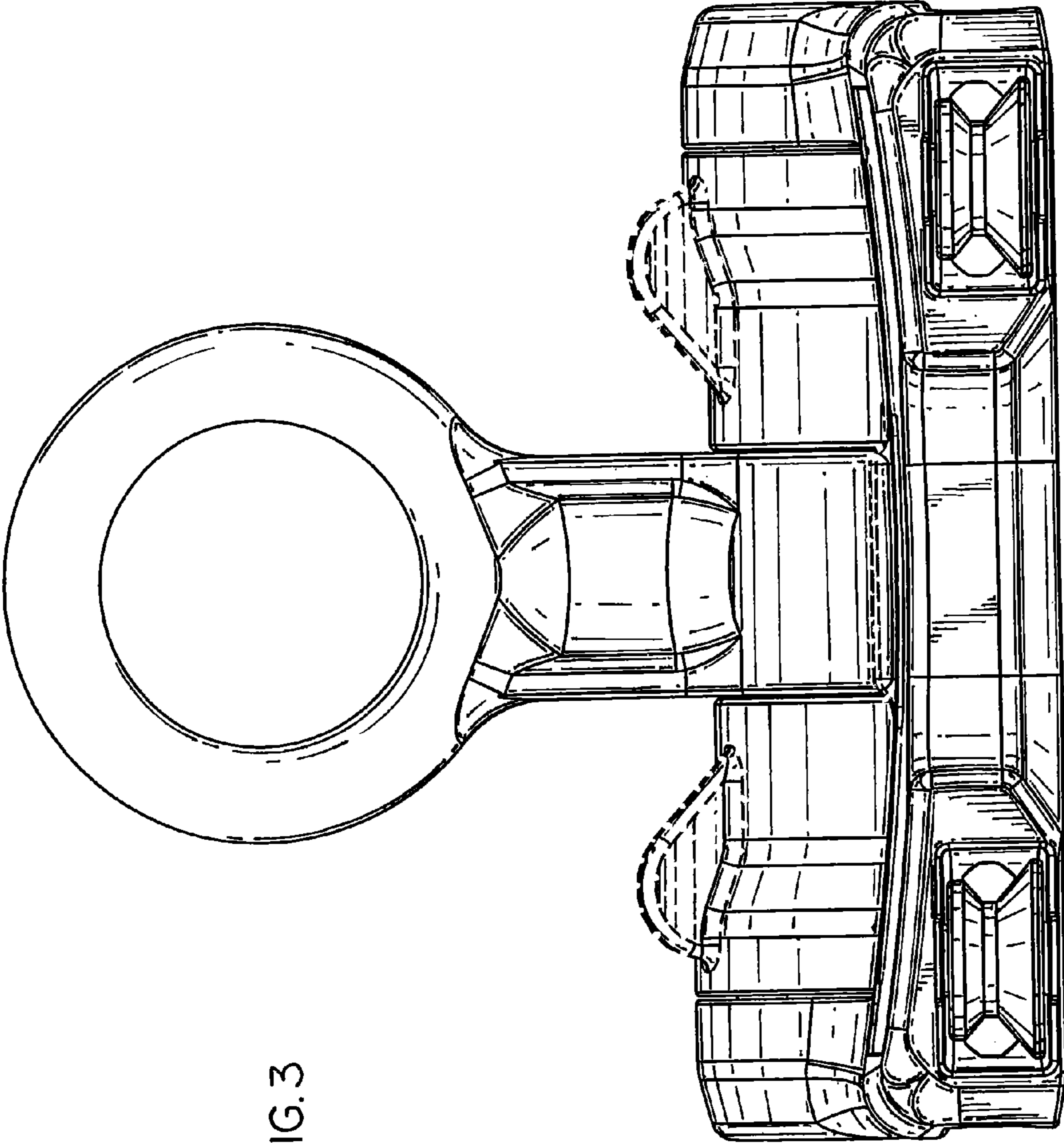

FIG.3

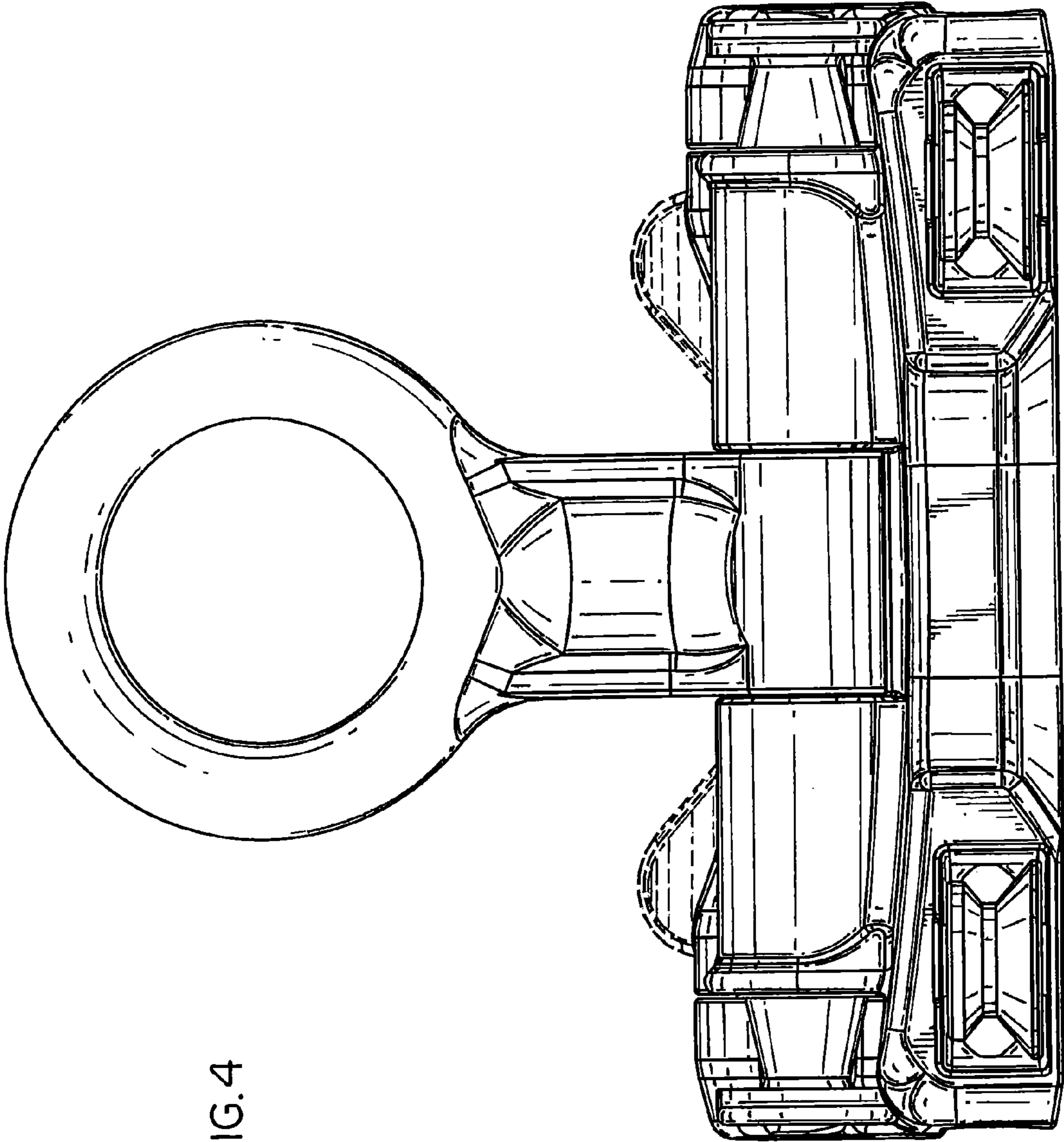

FIG.4

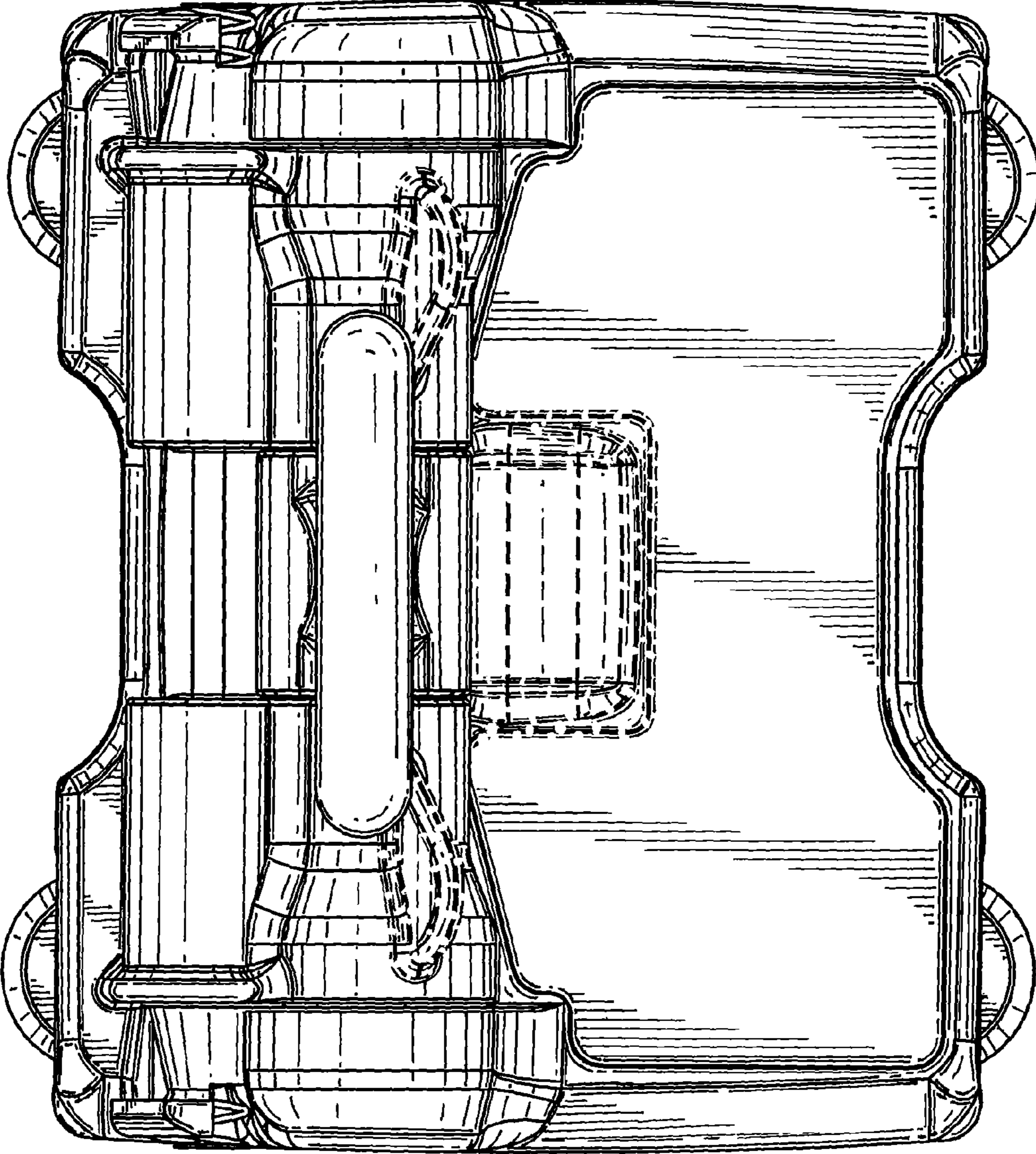

FIG. 5

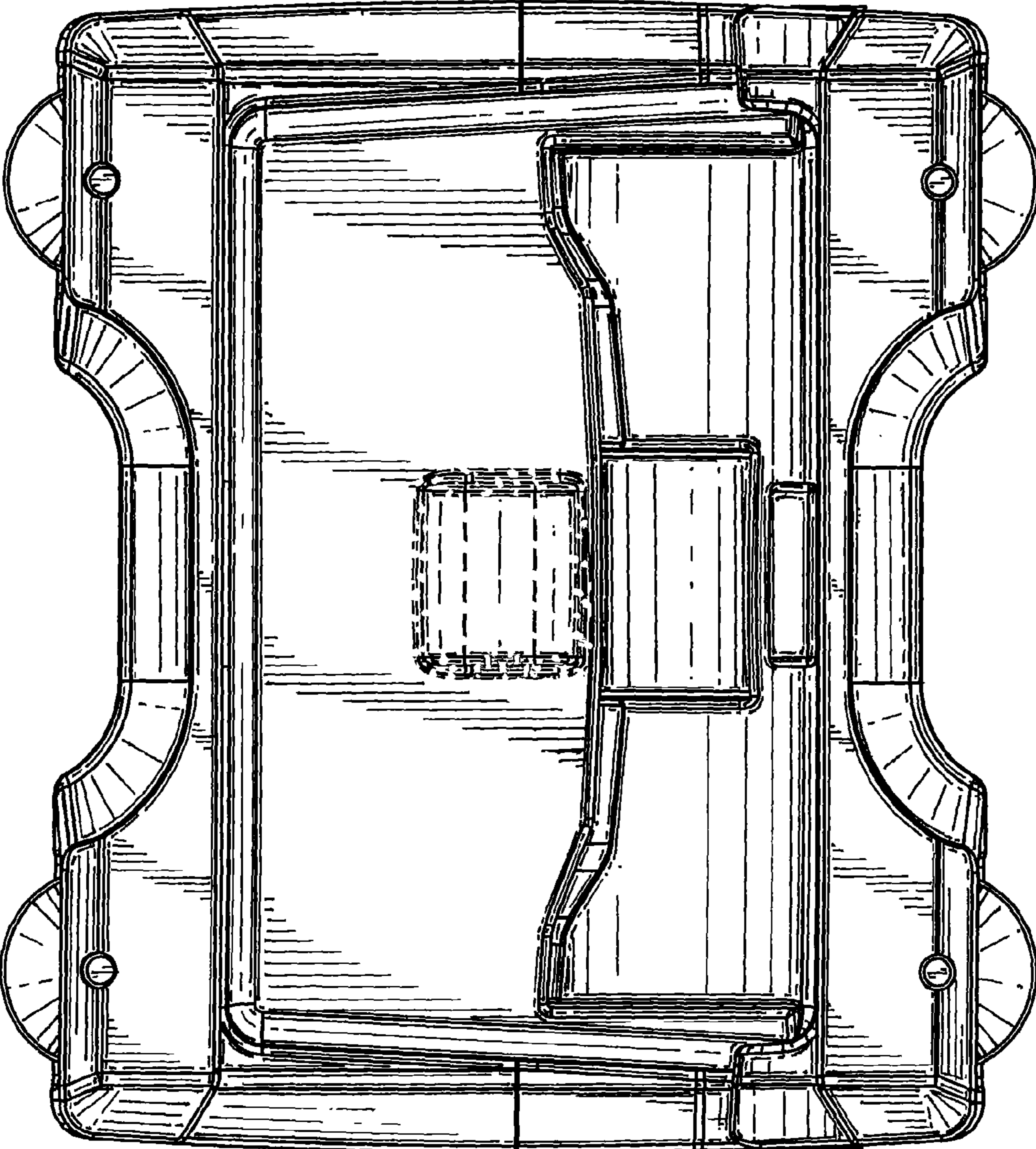

FIG. 6