



US00D679645S

(12) **United States Design Patent**  
**Chung**

(10) **Patent No.:** **US D679,645 S**

(45) **Date of Patent:** **\*\* Apr. 9, 2013**

(54) **WHEEL**

(71) Applicant: **Suny Chung**, Yorba Linda, CA (US)

(72) Inventor: **Suny Chung**, Yorba Linda, CA (US)

(73) Assignee: **Wheel Pros, LLC**, Lakewood, CO (US)

(\*\*) Term: **14 Years**

(21) Appl. No.: **29/433,615**

(22) Filed: **Oct. 2, 2012**

(51) **LOC (9) Cl.** ..... **12-16**

(52) **U.S. Cl.** ..... **D12/209**

(58) **Field of Classification Search** ..... D12/204-213;  
301/37.101, 64.101, 65, 64.201

See application file for complete search history.

(56) **References Cited**

**U.S. PATENT DOCUMENTS**

D493,405 S *	7/2004	Boyer	.....	D12/211
D508,671 S *	8/2005	Baum	.....	D12/209
D525,577 S *	7/2006	Laengerer	.....	D12/211
D536,294 S *	2/2007	Laengerer	.....	D12/211
D597,917 S *	8/2009	Chung	.....	D12/209
D615,916 S *	5/2010	Leone	.....	D12/211
D620,872 S *	8/2010	Juergens et al.	.....	D12/211
D643,793 S *	8/2011	Juergens et al.	.....	D12/209
D662,868 S *	7/2012	Furst et al.	.....	D12/209
D669,011 S *	10/2012	Chung	.....	D12/211

\* cited by examiner

*Primary Examiner* — Stacia Cadmus

(74) *Attorney, Agent, or Firm* — Garcia-Zamor IP Law; Ruy M. Garcia-Zamor

(57) **CLAIM**

The ornamental design for a wheel, as shown and described.

**DESCRIPTION**

FIG. 1 is a perspective view of a wheel showing my new design;

FIG. 2 is a front elevational view of the wheel of FIG. 1;

FIG. 3 is a left side elevational view of the wheel of FIG. 1, the right side elevational view of the wheel of FIG. 1 is a mirror image of FIG. 3;

FIG. 4 is a top plan view of the wheel of FIG. 1;

FIG. 5 is a bottom plan view of the wheel of FIG. 1;

FIG. 6 is a rear elevational view of the wheel of FIG. 1;

FIG. 7 is a perspective view of a wheel according to a second preferred embodiment of my new design;

FIG. 8 is a front elevational view of the wheel of FIG. 7;

FIG. 9 is a left side elevational view of the wheel of FIG. 7, the right side elevational view of the wheel of FIG. 7 is a mirror image of FIG. 9;

FIG. 10 is a top plan view of the wheel of FIG. 7;

FIG. 11 is a bottom plan view of the wheel of FIG. 7; and,

FIG. 12 is a rear elevational view of the wheel of FIG. 7.

The broken lines in FIGS. 1-12 represent environment and are for illustrative purposes only and do not constitute part of the claimed design.

**1 Claim, 10 Drawing Sheets**

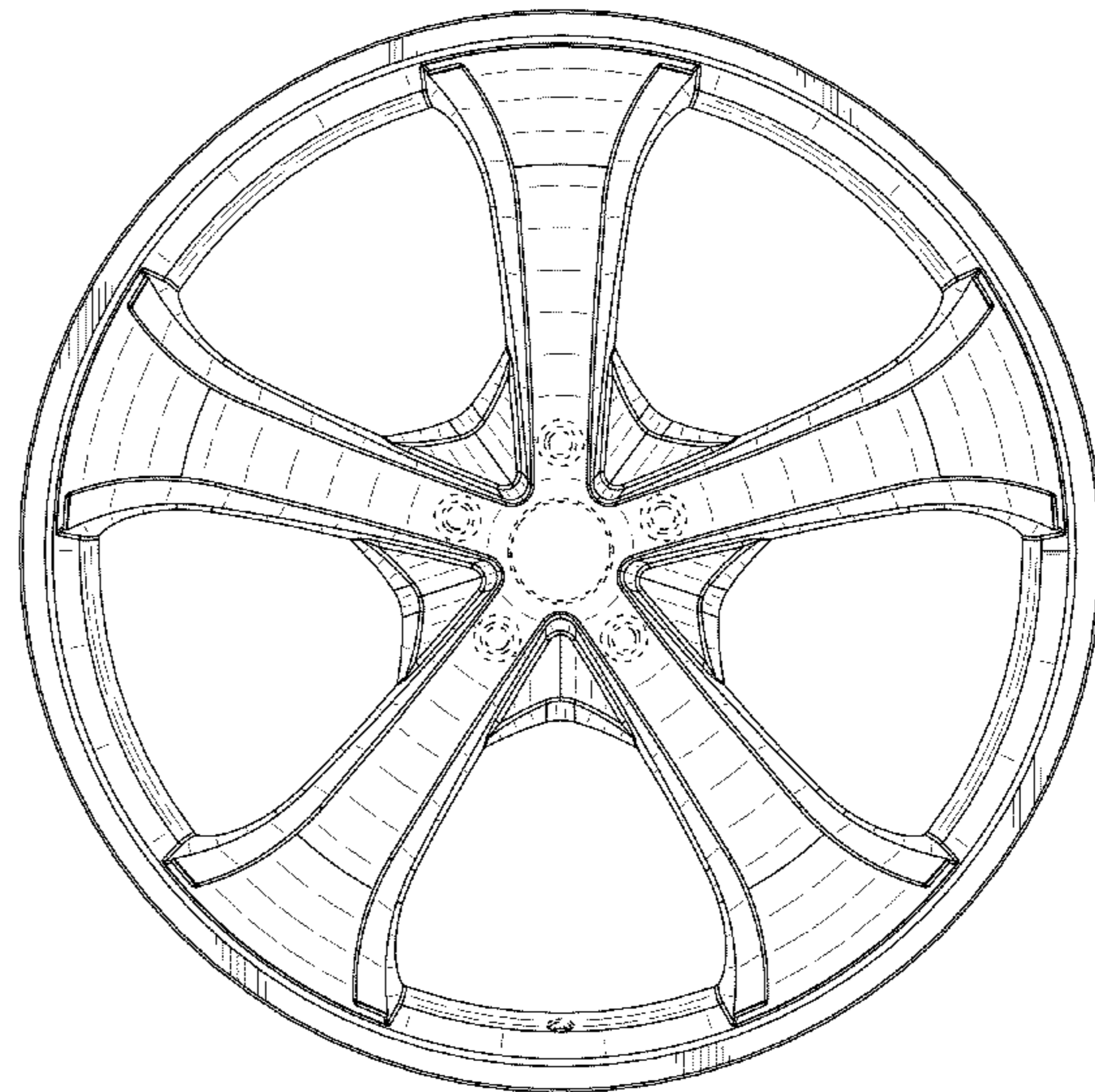
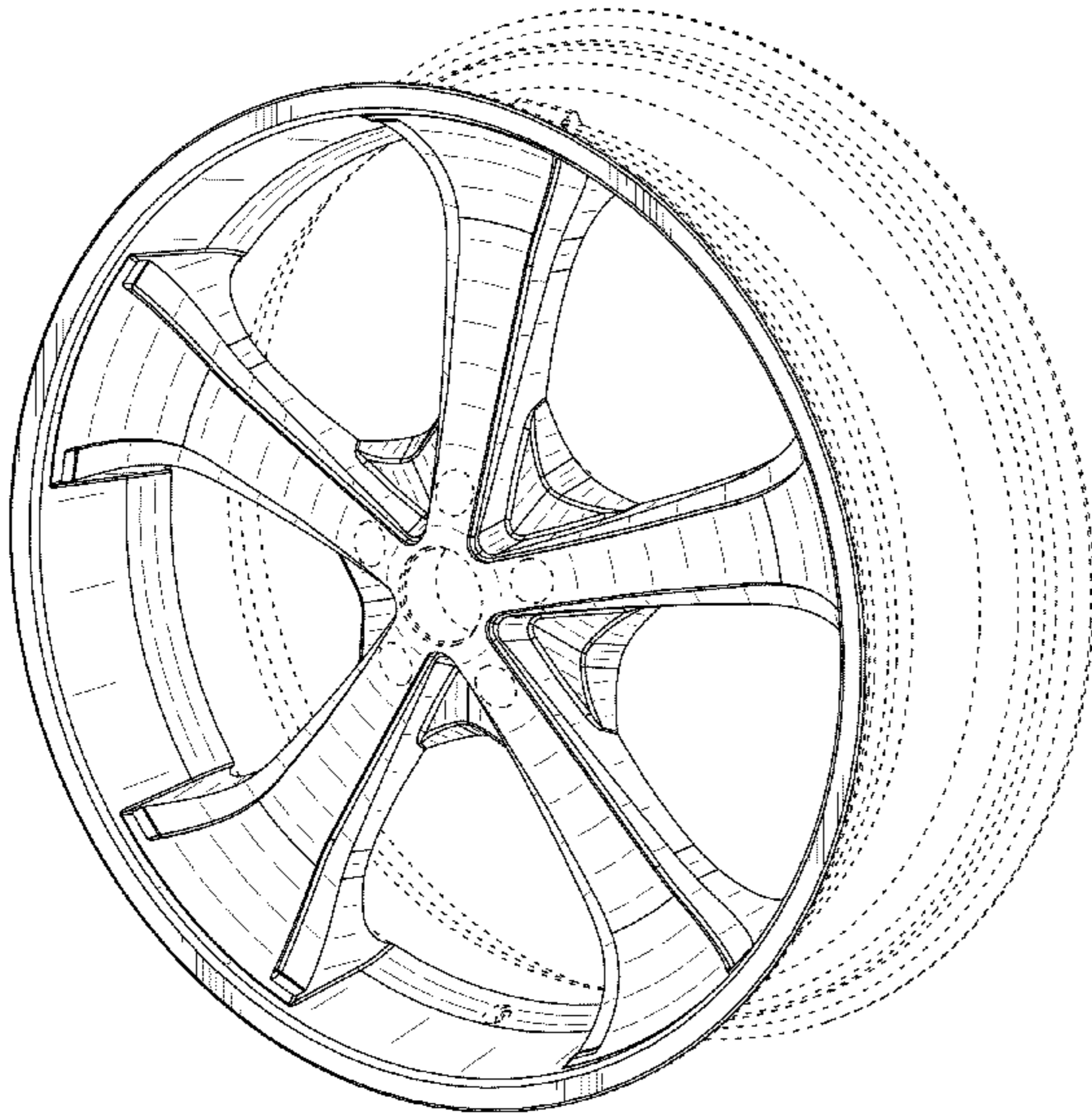

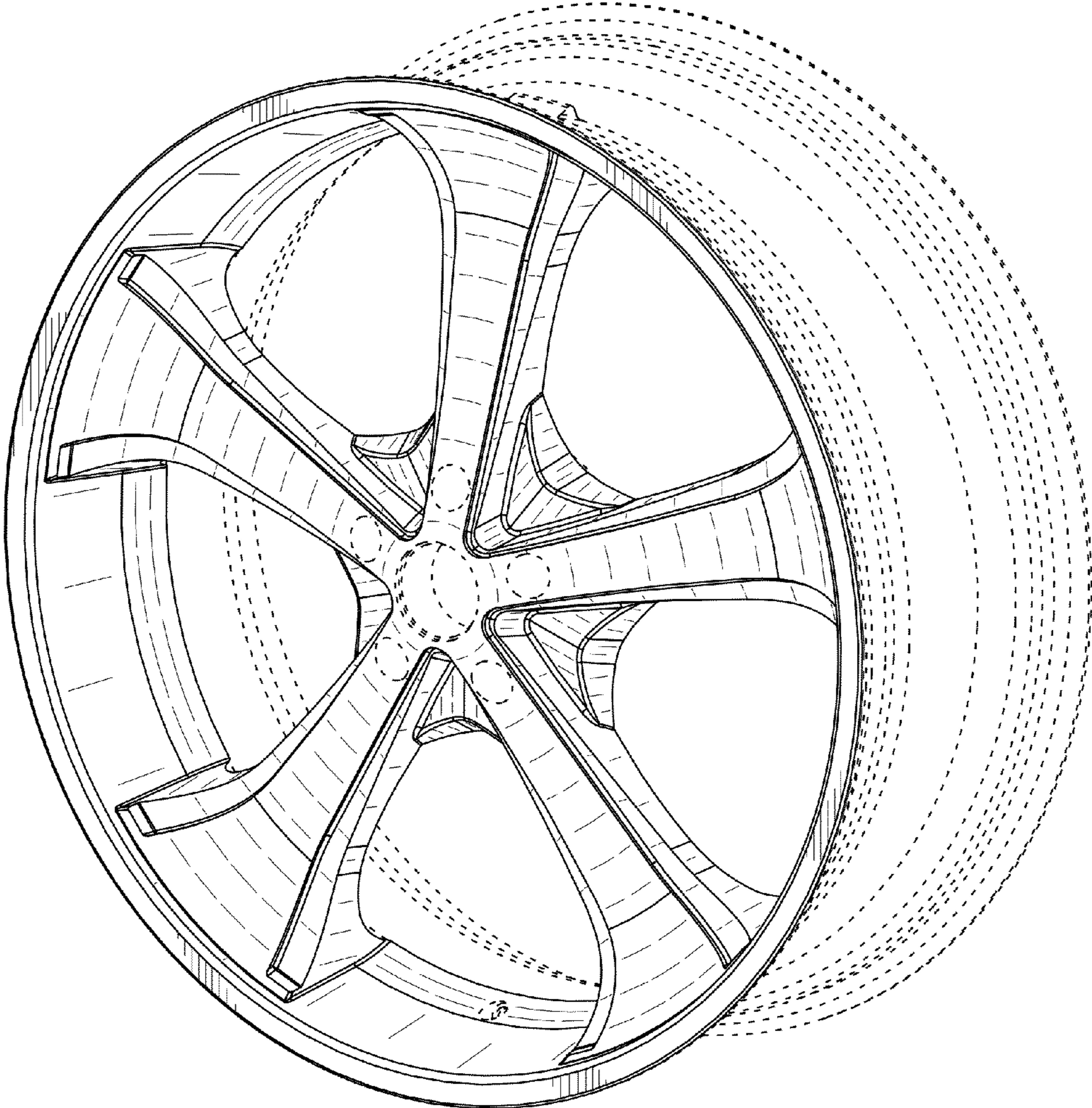

FIG. 1

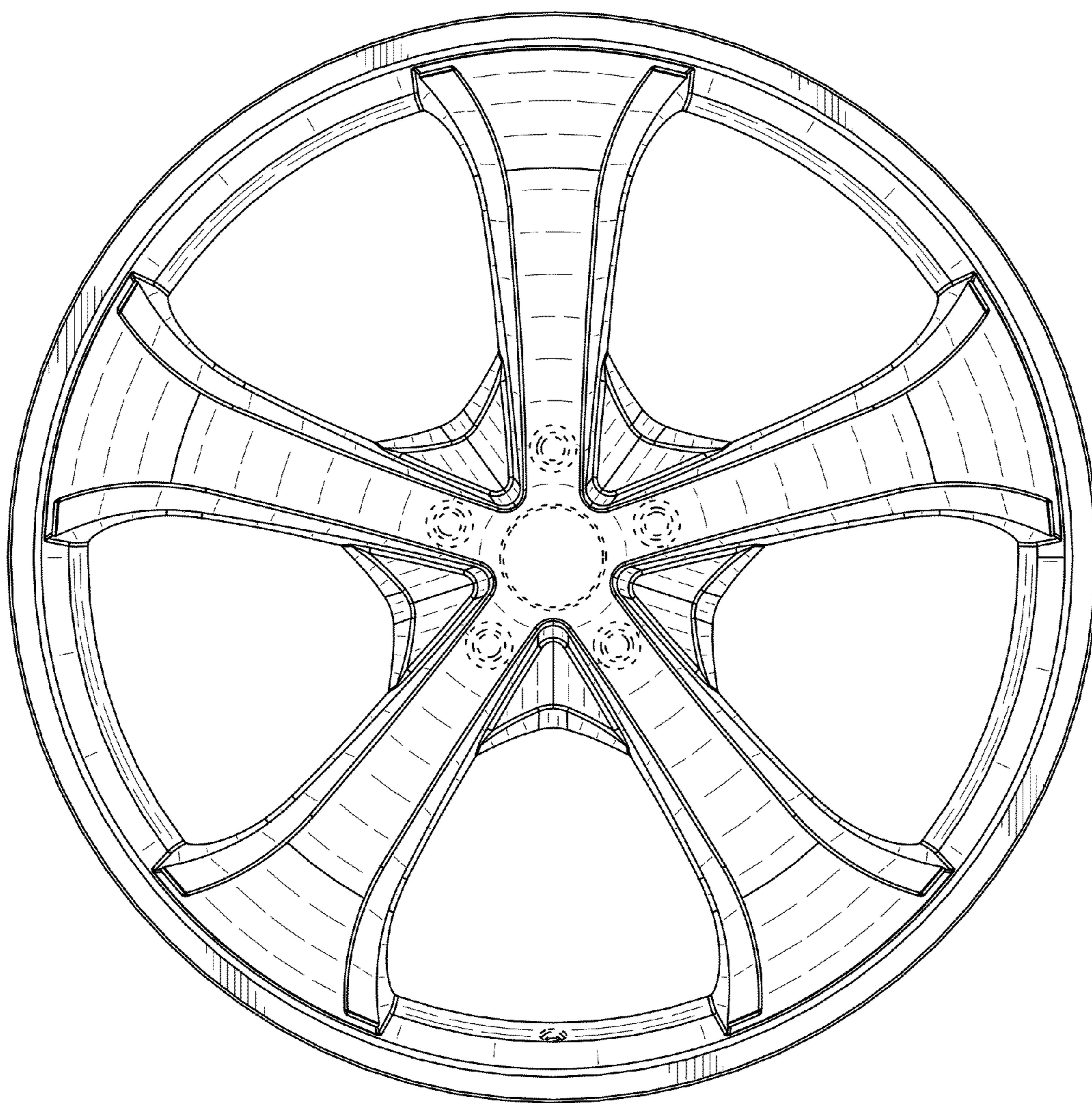
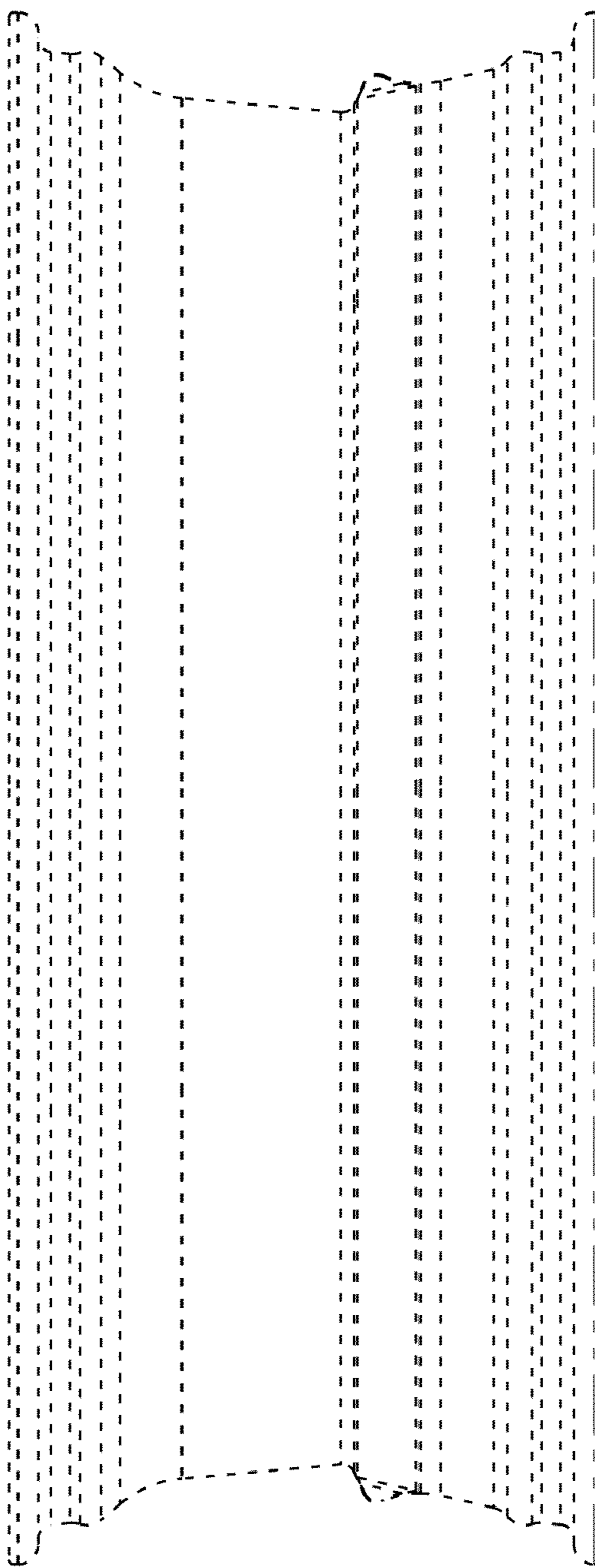

FIG. 2



**FIG. 3**

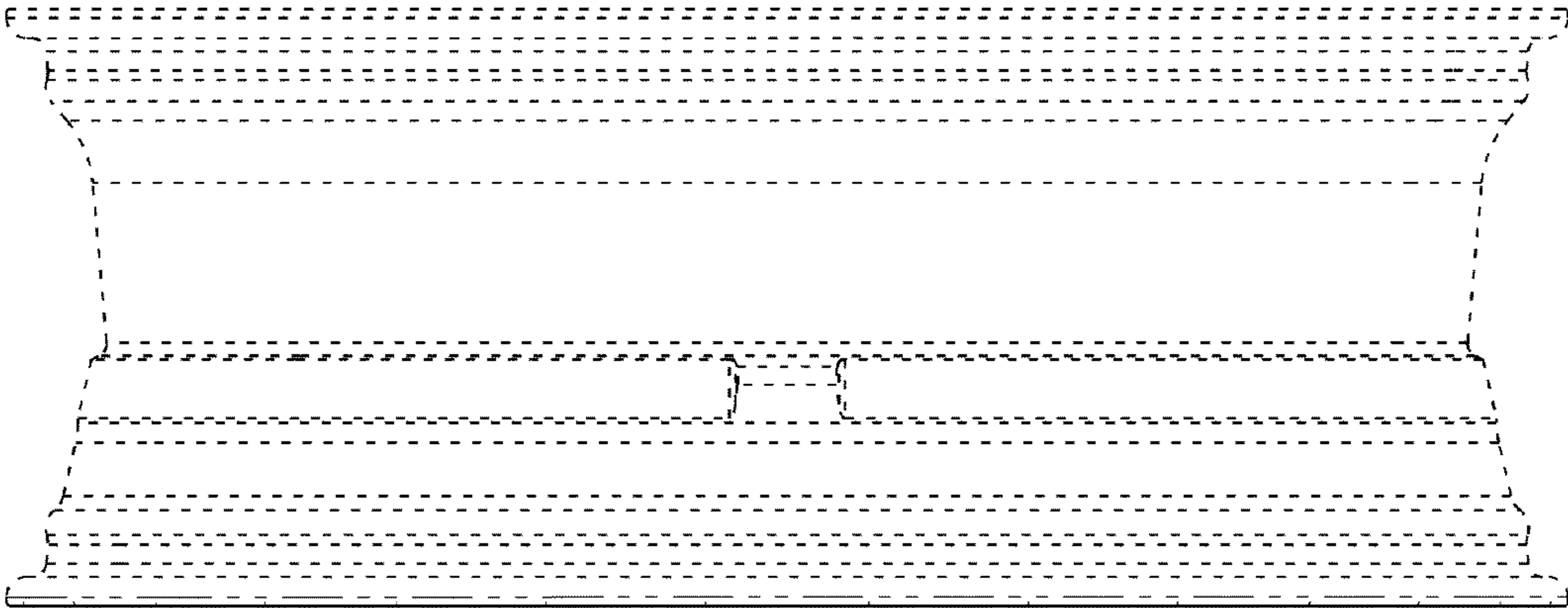

FIG. 4

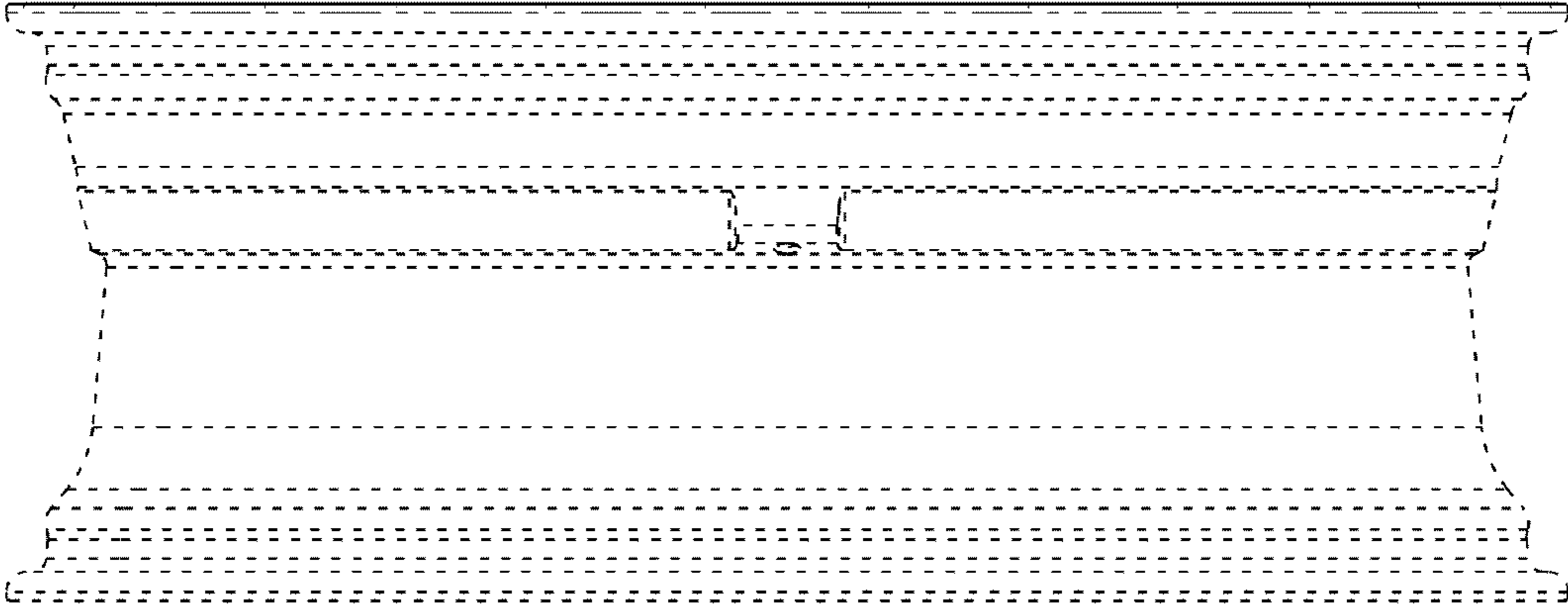

FIG. 5

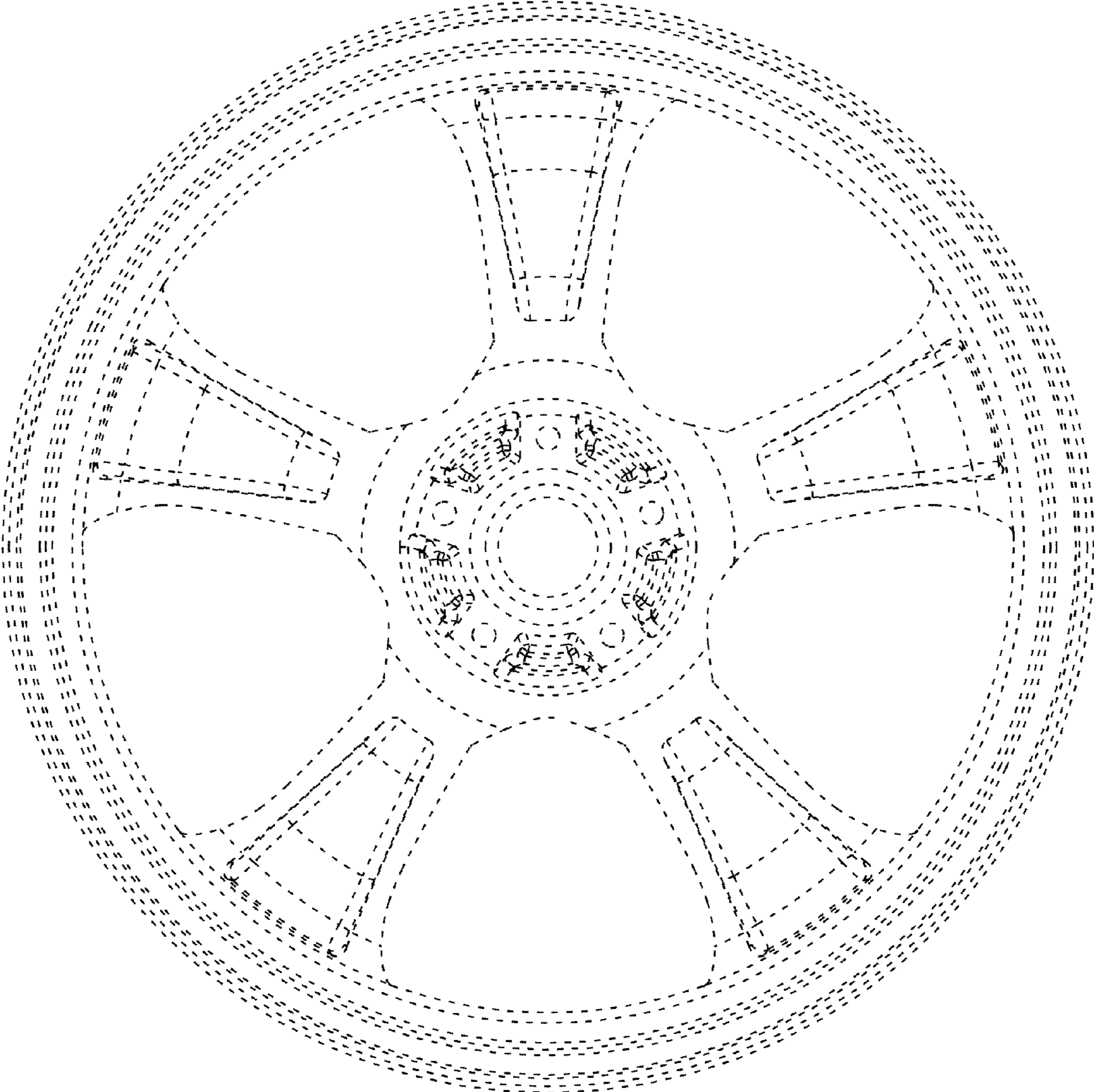

FIG. 6

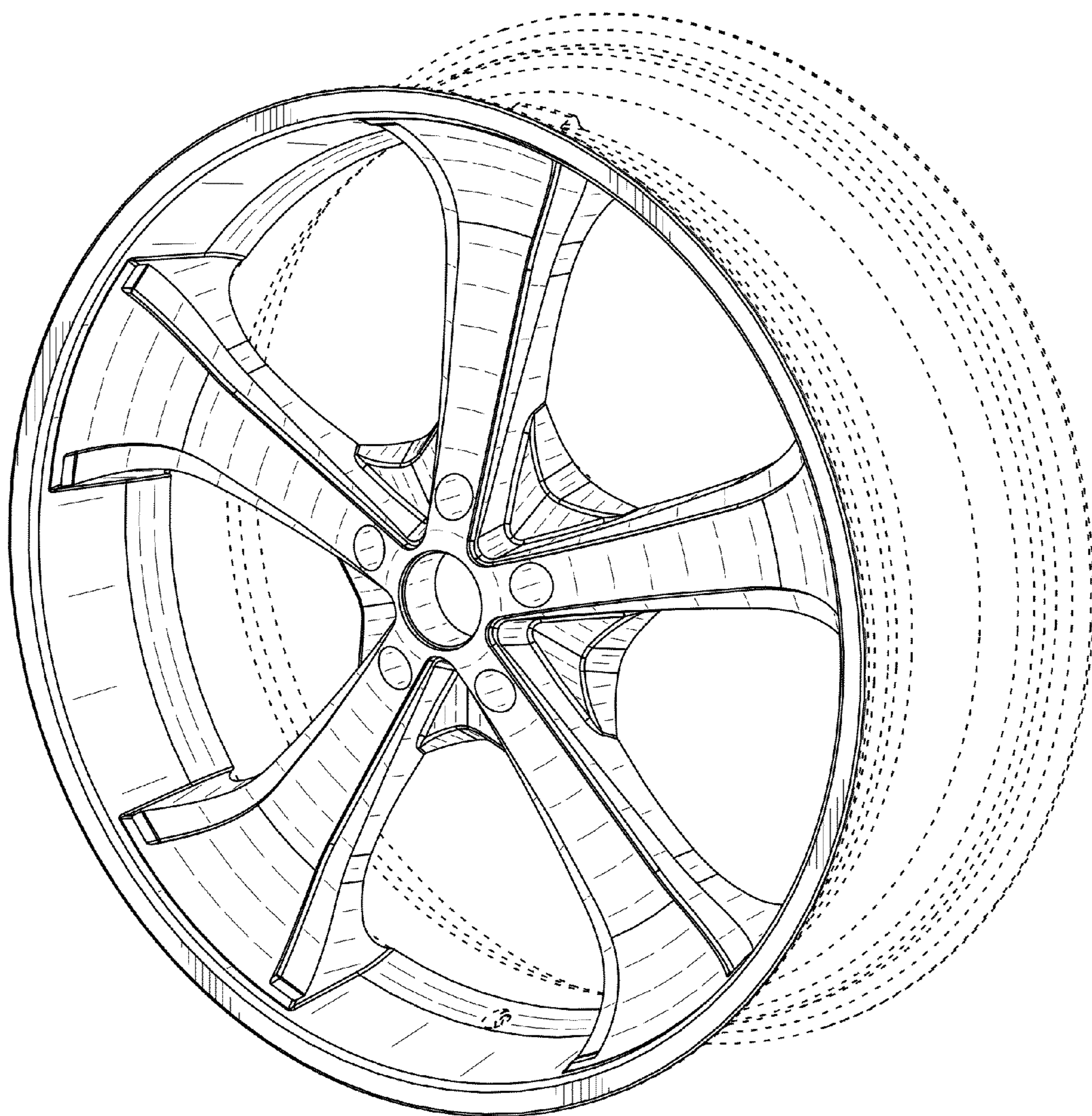

FIG. 7

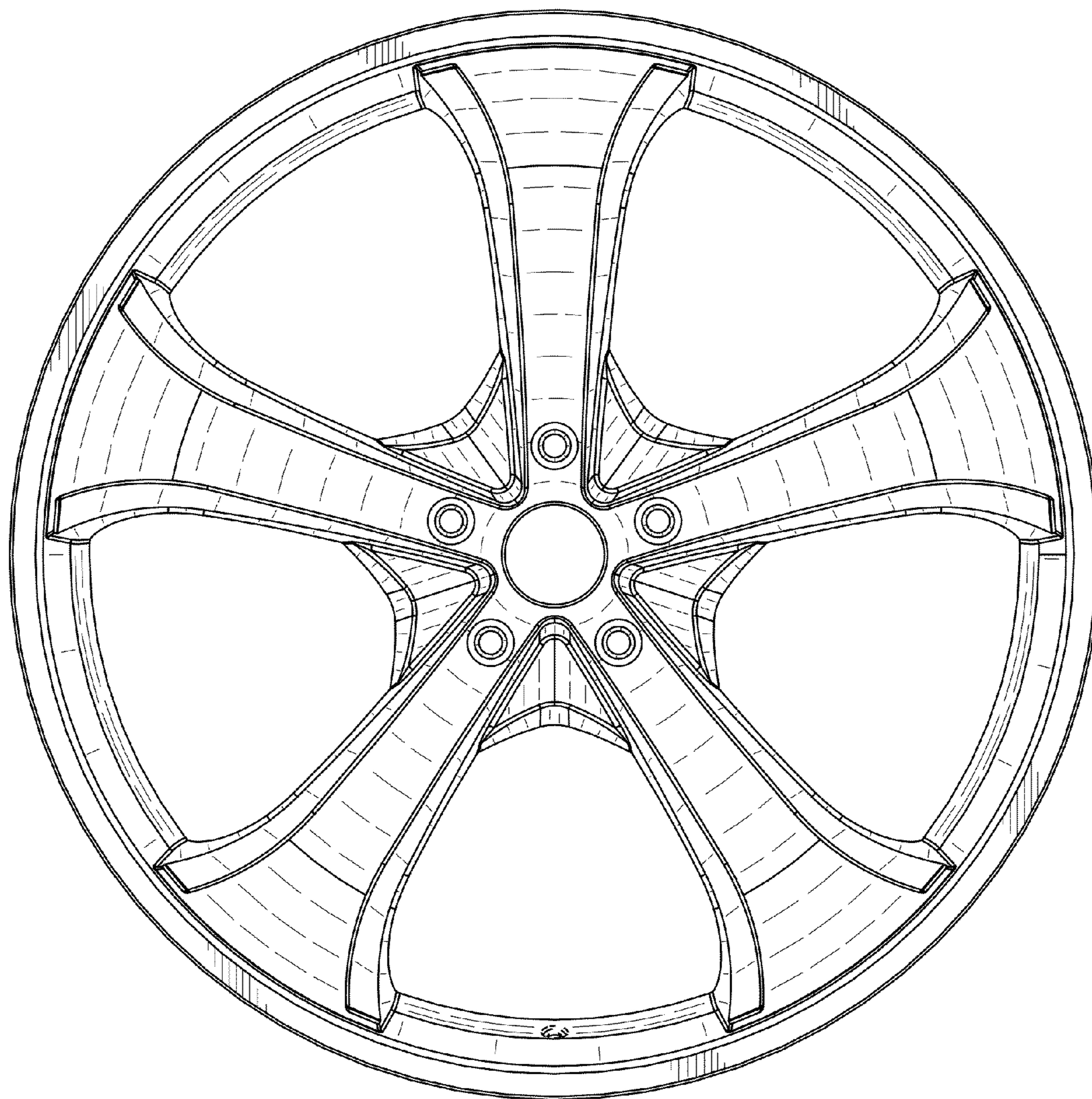

FIG. 8



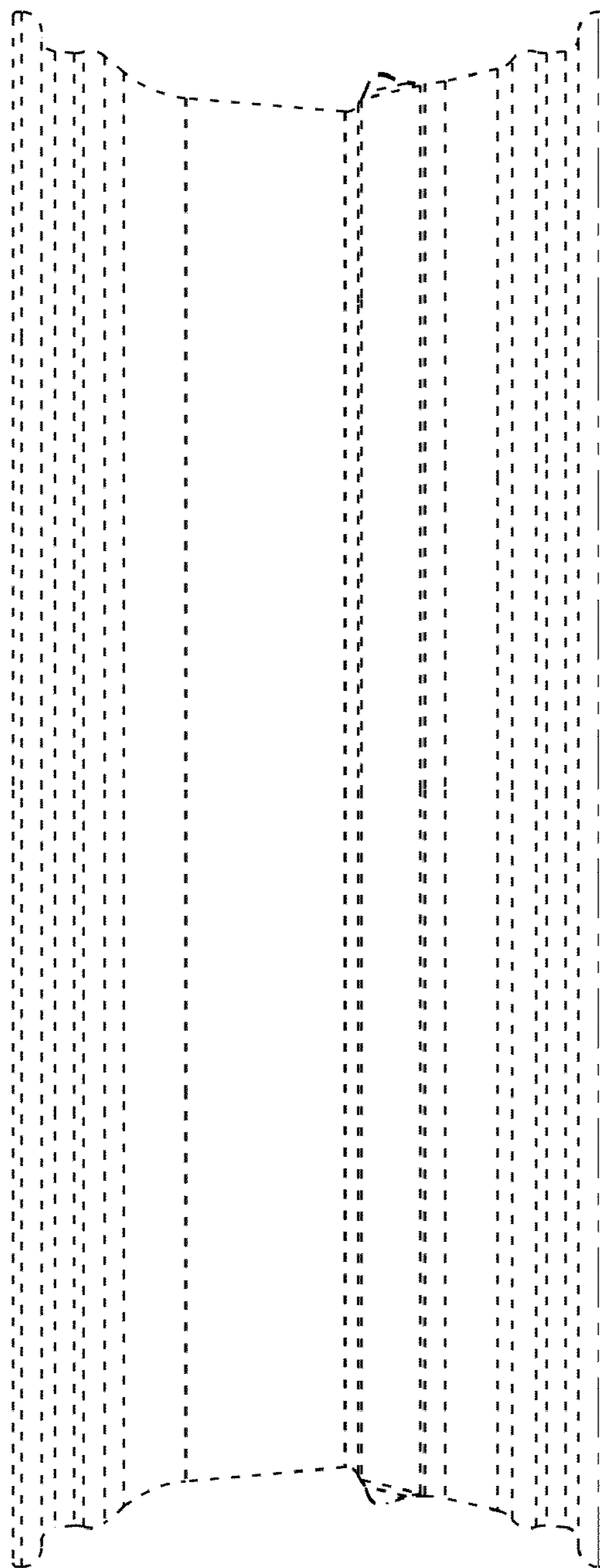

FIG. 9

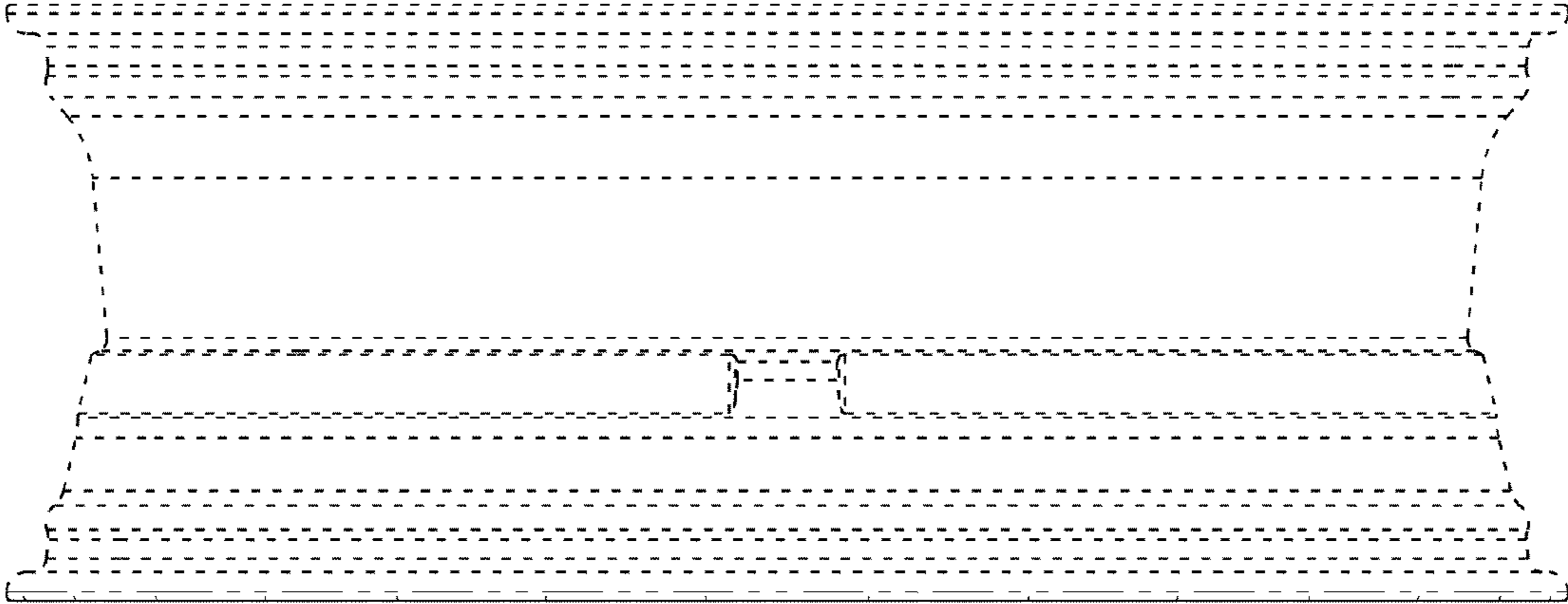

FIG. 10

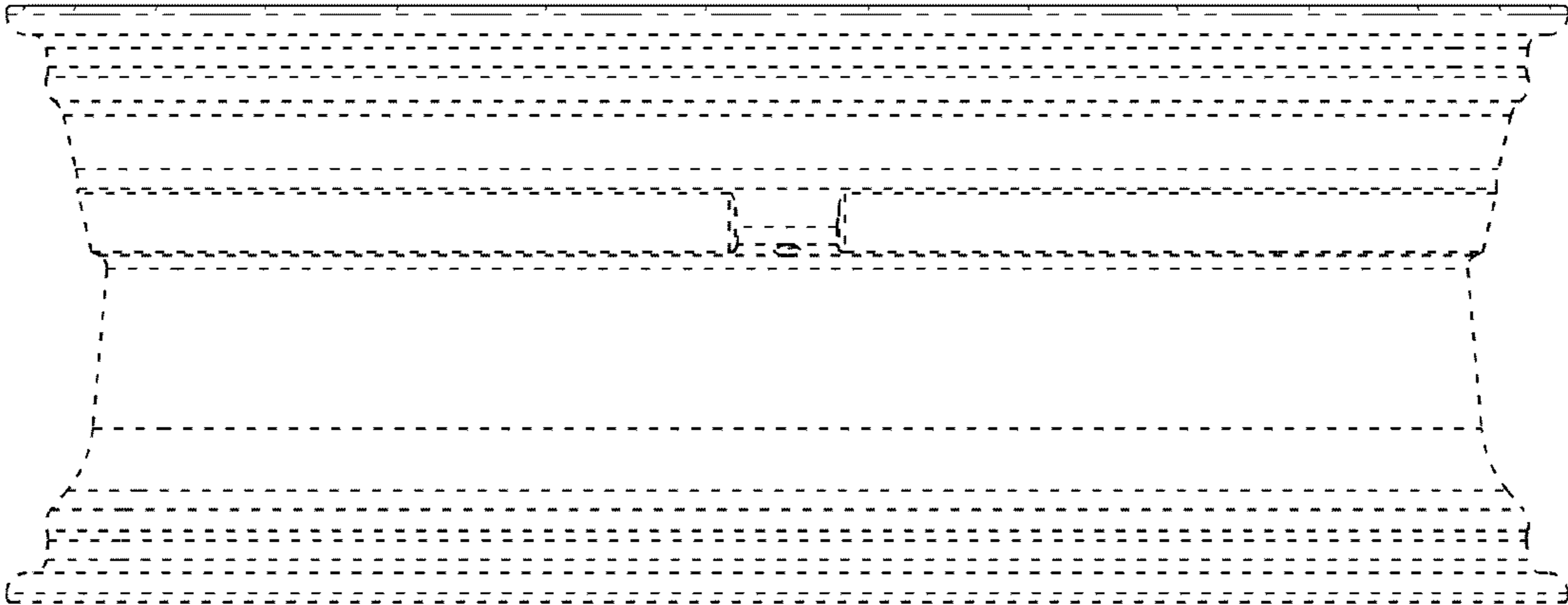

FIG. 11

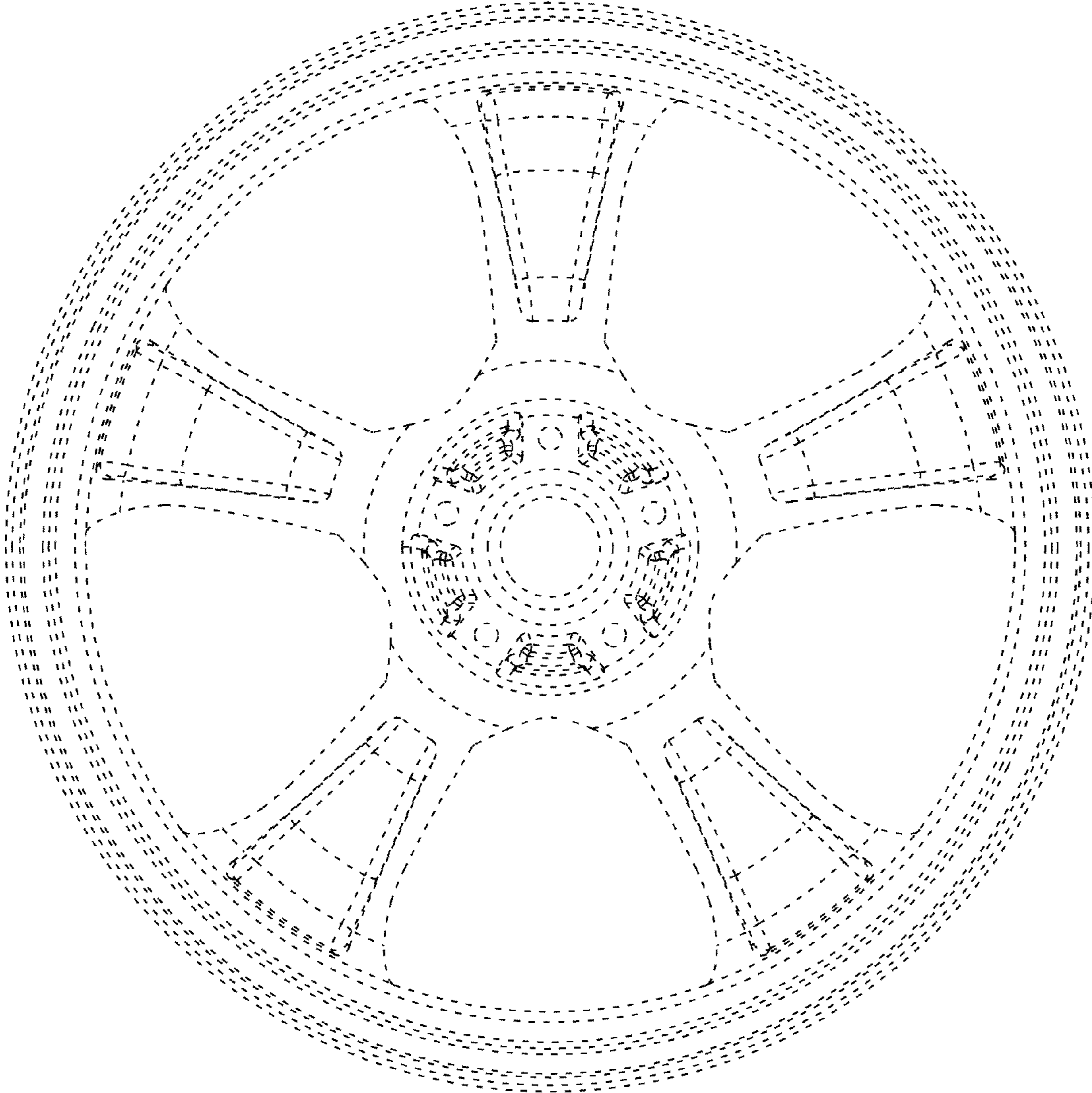

FIG. 12