



US00D679236S

(12) **United States Design Patent**
Gros et al.

(10) **Patent No.:** **US D679,236 S**

(45) **Date of Patent:** **** Apr. 2, 2013**

(54) **BOAT**

(76) Inventors: **Charles P. Gros**, White City, OR (US);
Eugene W. Gros, White City, OR (US)

(**) Term: **14 Years**

(21) Appl. No.: **29/382,764**

(22) Filed: **Jan. 6, 2011**

(51) **LOC (9) Cl.** **12-06**

(52) **U.S. Cl.** **D12/300**

(58) **Field of Classification Search** D12/300,
D12/302, 303, 304, 307, 310–314, 316, 317;
114/39.11–39.15, 39.21–39.32, 61.1, 61.2,
114/61.32, 61.33, 62, 355–358, 271, 273,
114/283, 288–292, 343, 363, 364; 440/27,
440/35

See application file for complete search history.

(56) **References Cited**

U.S. PATENT DOCUMENTS

D264,573 S * 5/1982 Rogers D12/310
D320,377 S * 10/1991 Livingston et al. D12/314

D329,038 S * 9/1992 Dekker et al. D12/314
D488,117 S * 4/2004 Bills et al. D12/300
8,196,542 B2 * 6/2012 Oswell et al. 114/364

* cited by examiner

Primary Examiner — Cynthia M Chin

(74) *Attorney, Agent, or Firm* — QuickPatents; Kevin Prince

(57) **CLAIM**

We claim the ornamental design for a boat, as shown and described.

DESCRIPTION

FIG. 1 is a front perspective view of a boat, showing the new design;

FIG. 2 is a front elevational view thereof;

FIG. 3 is a rear elevational view thereof;

FIG. 4 is a right-side elevational view thereof;

FIG. 5 is a left-side elevational view thereof;

FIG. 6 is a top plan view thereof;

FIG. 7 is a bottom plan view thereof; and,

FIG. 8 is a rear perspective view thereof.

The broken lines in FIGS. 6 and 7 depict environmental matter that forms no part of the claimed design.

1 Claim, 8 Drawing Sheets

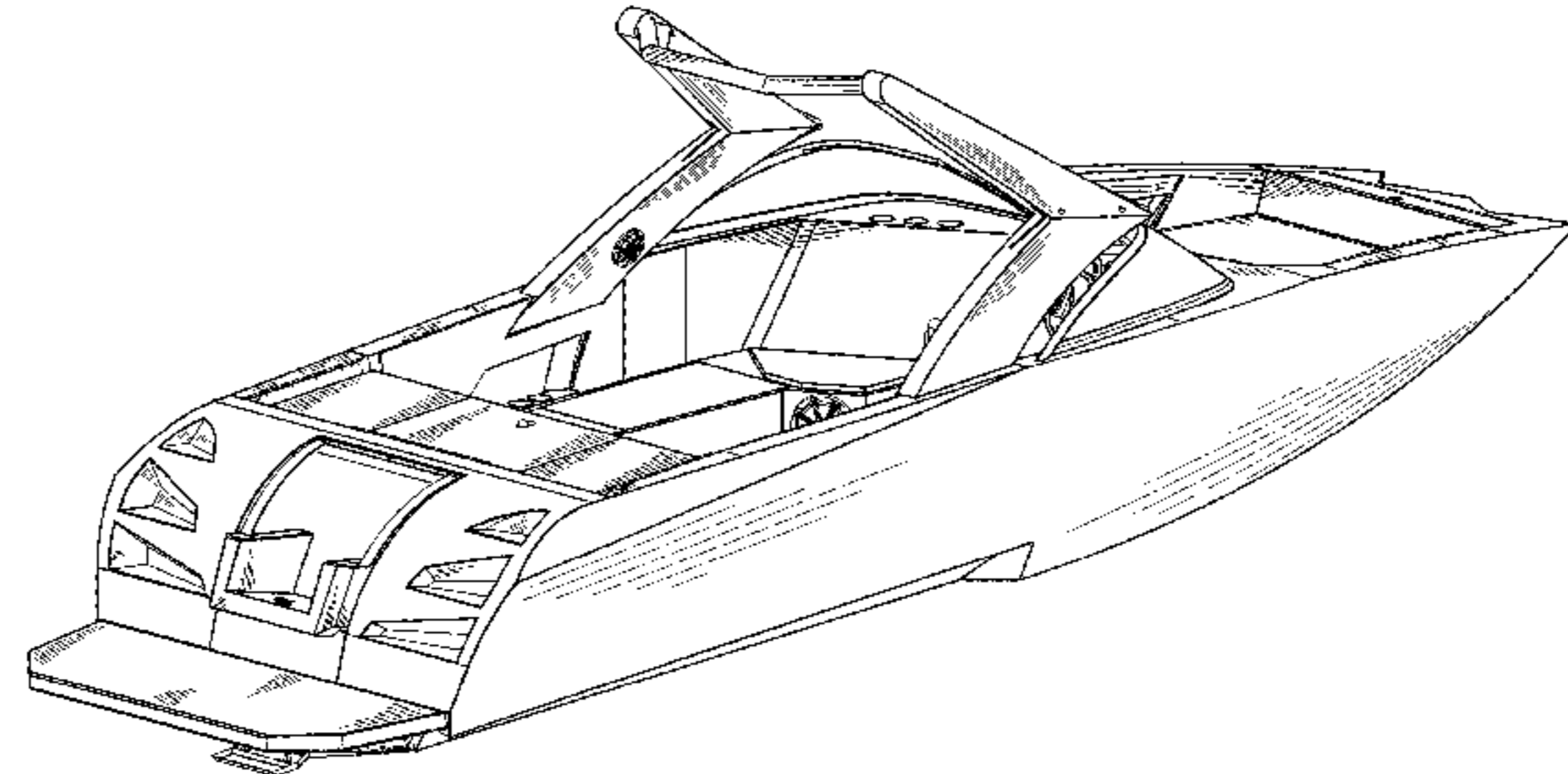
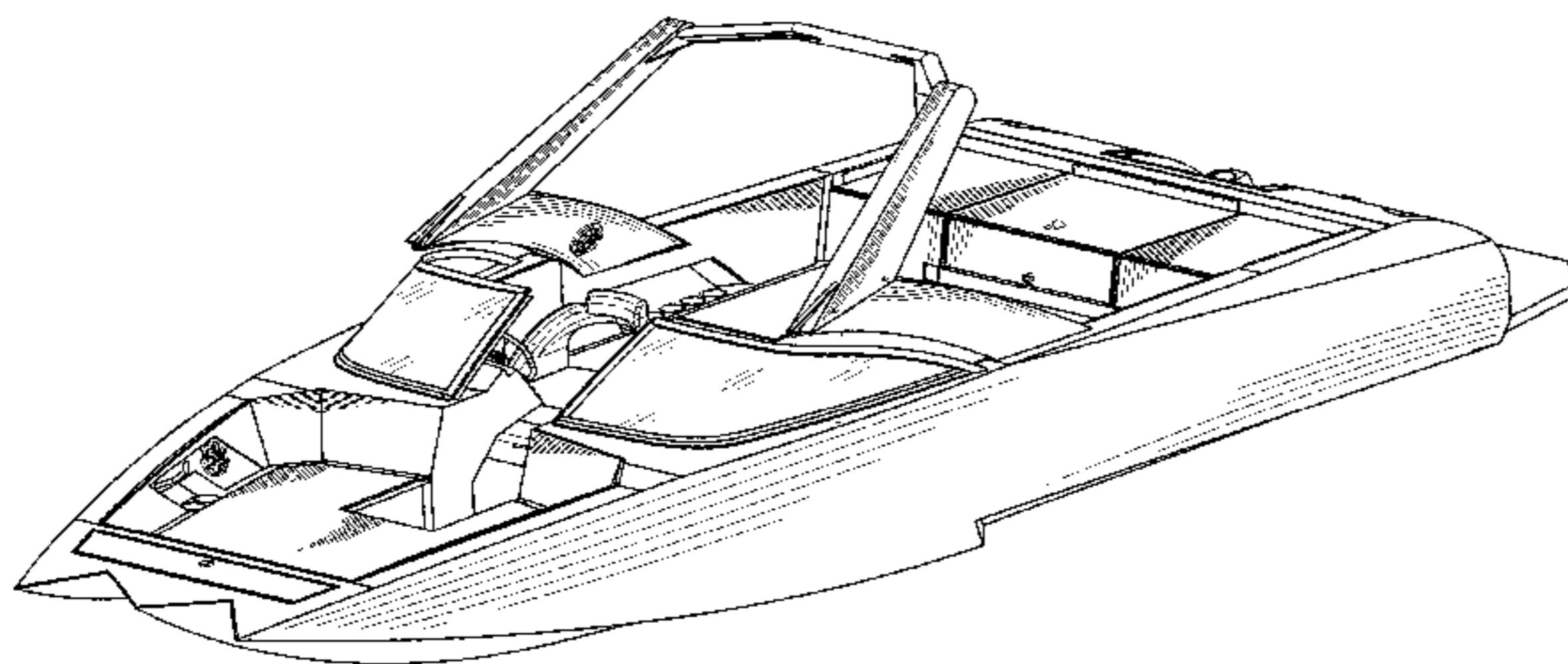

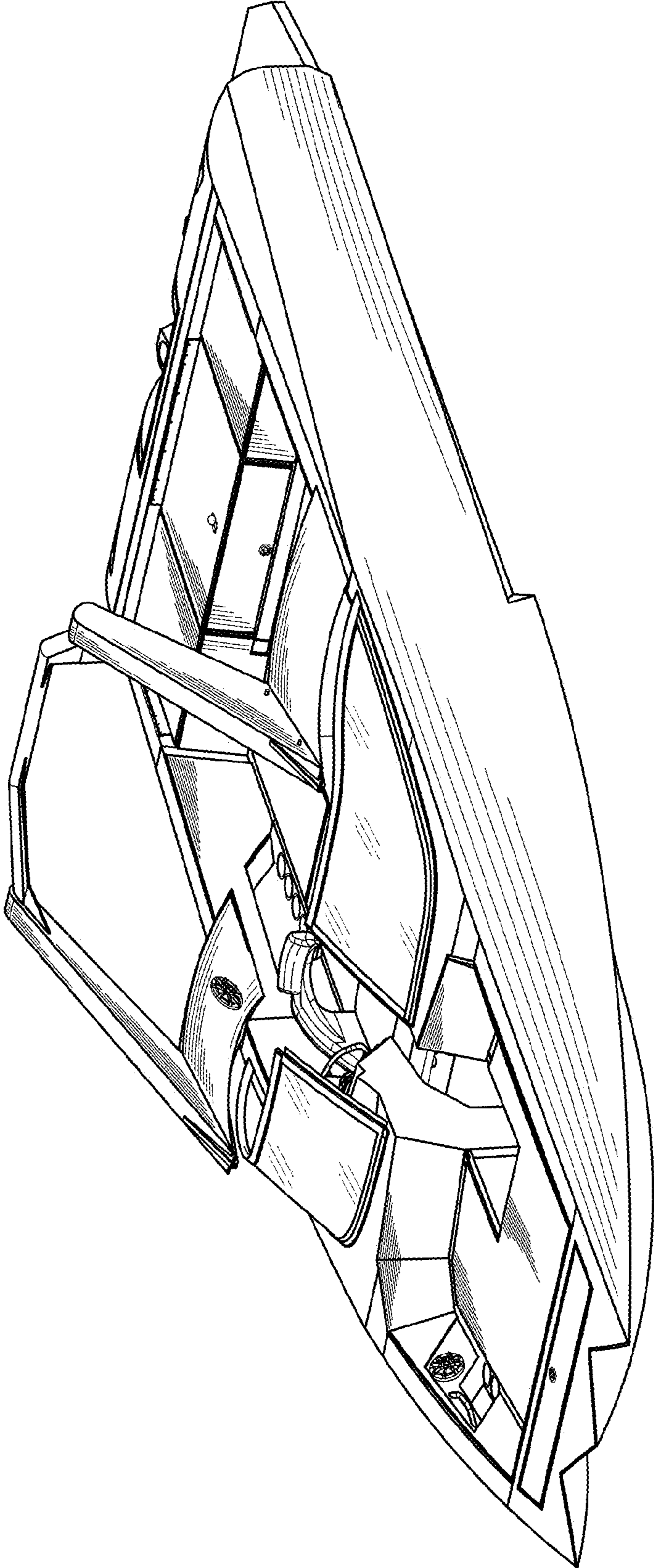

FIG. 1

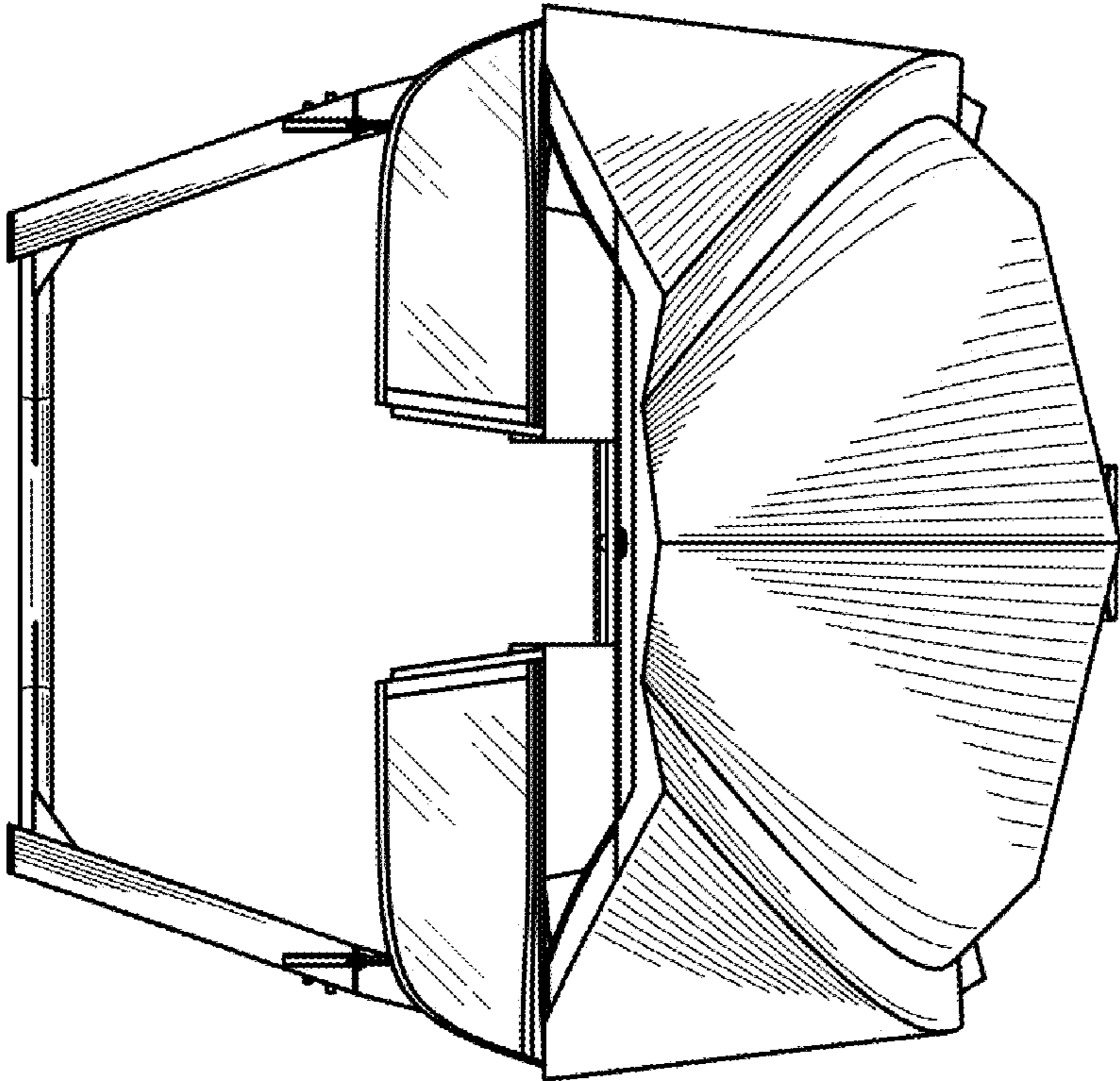

FIG. 2

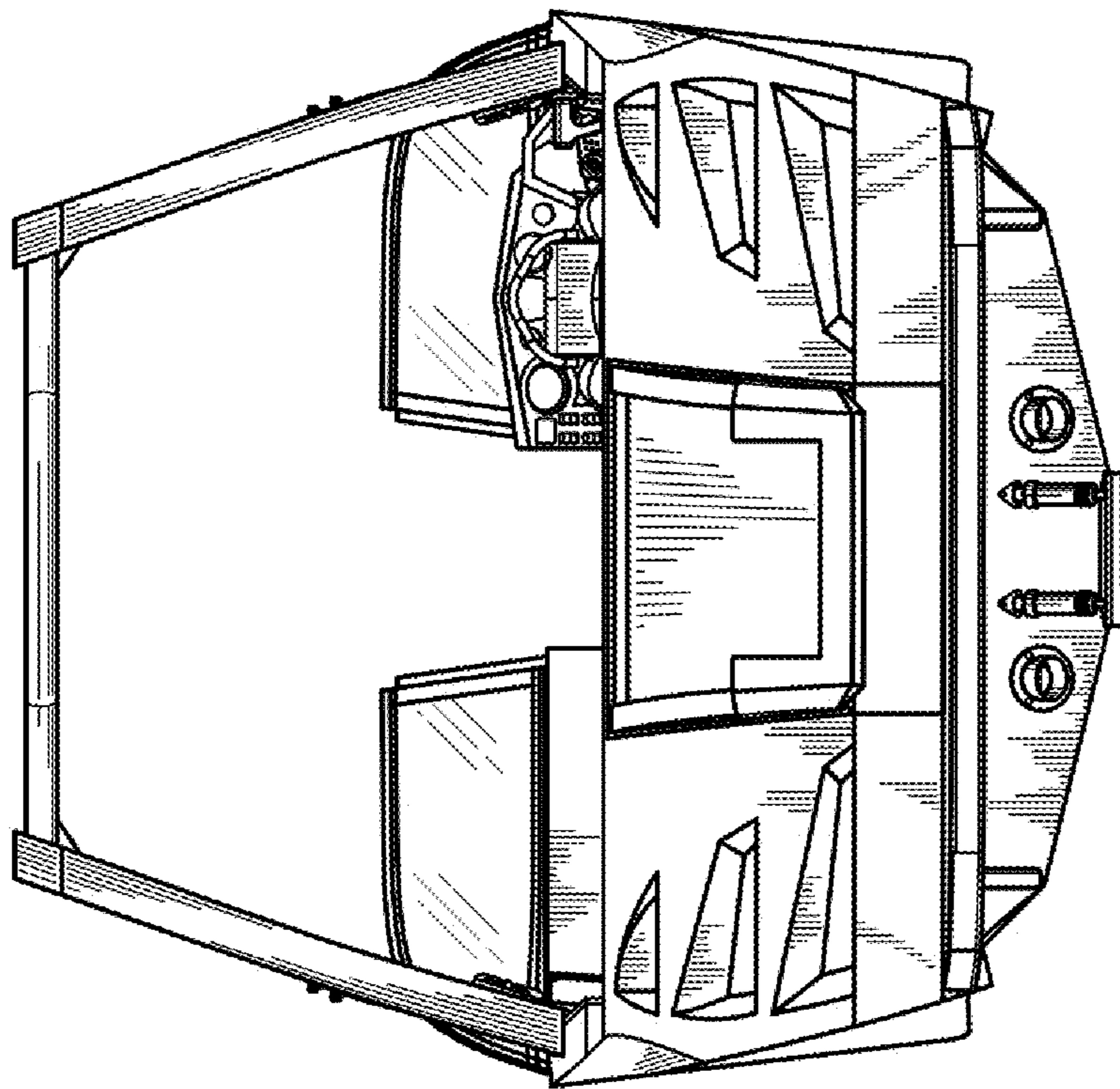

FIG. 3

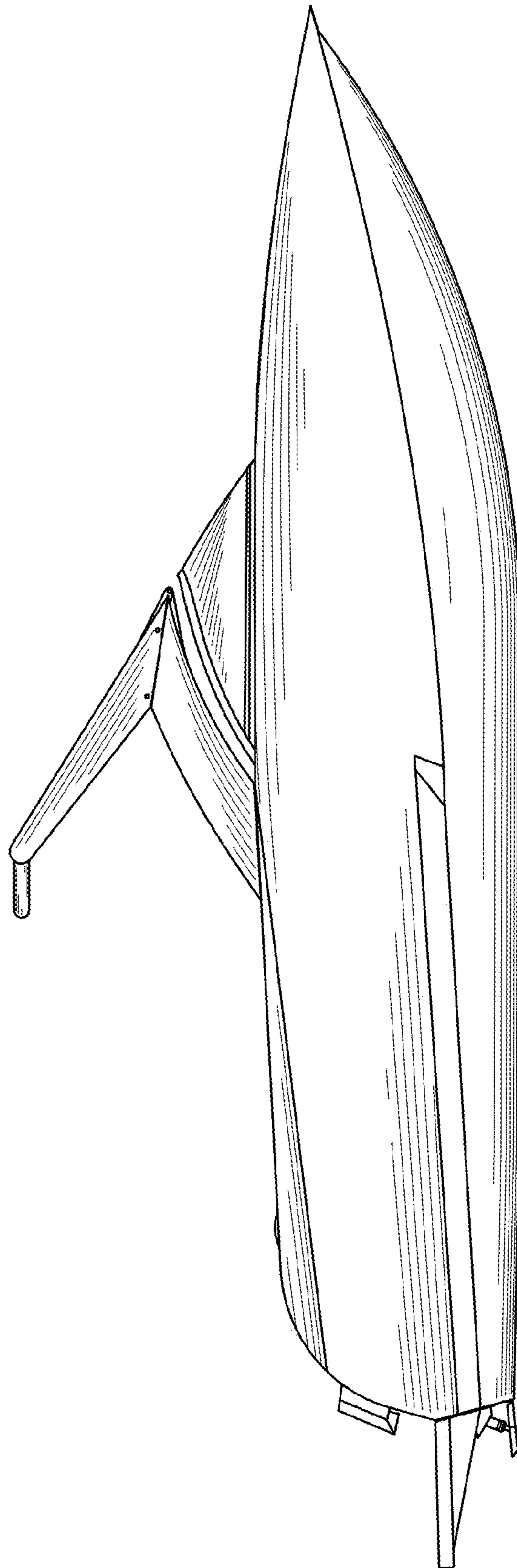

FIG. 4

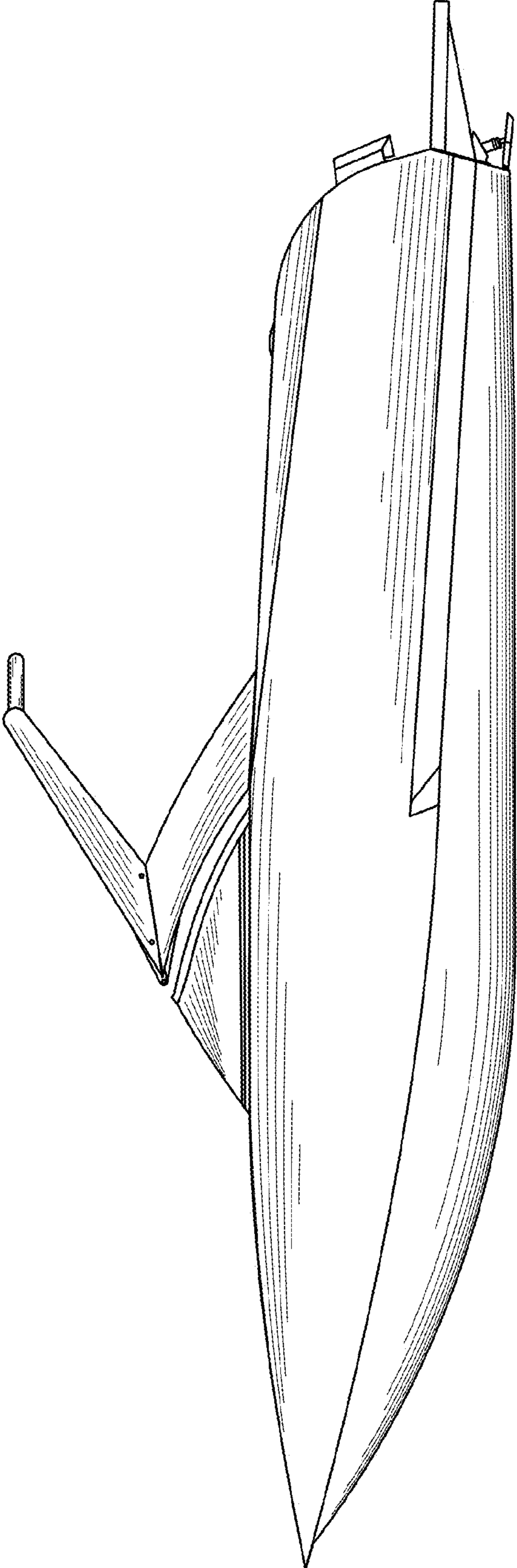

FIG. 5

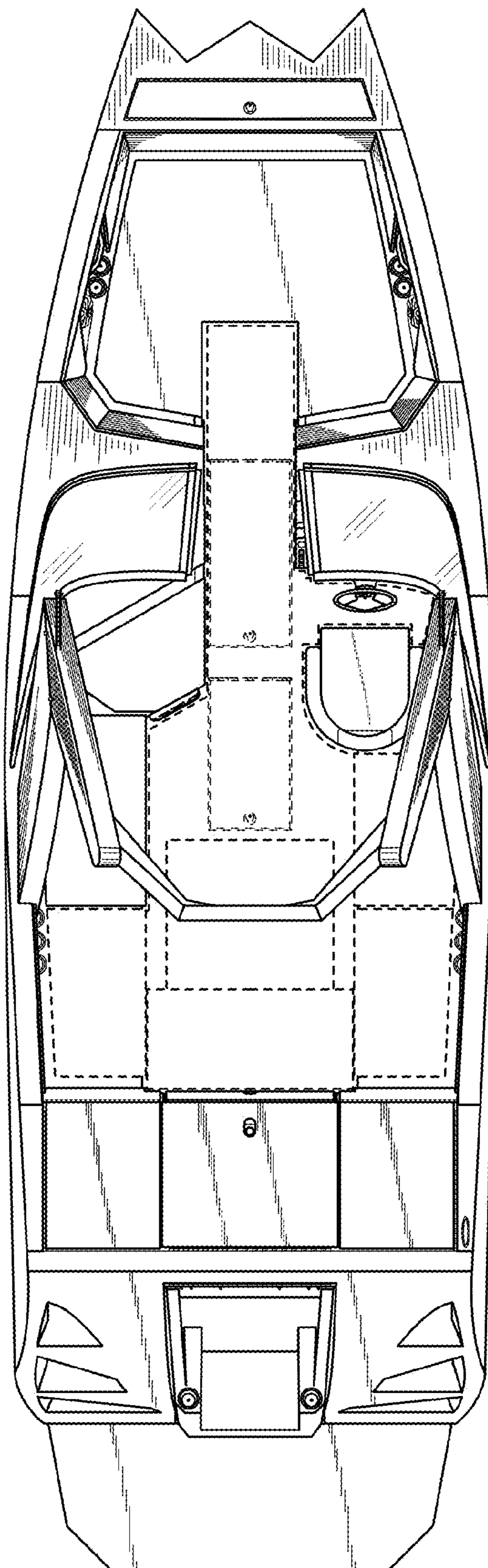

FIG. 6

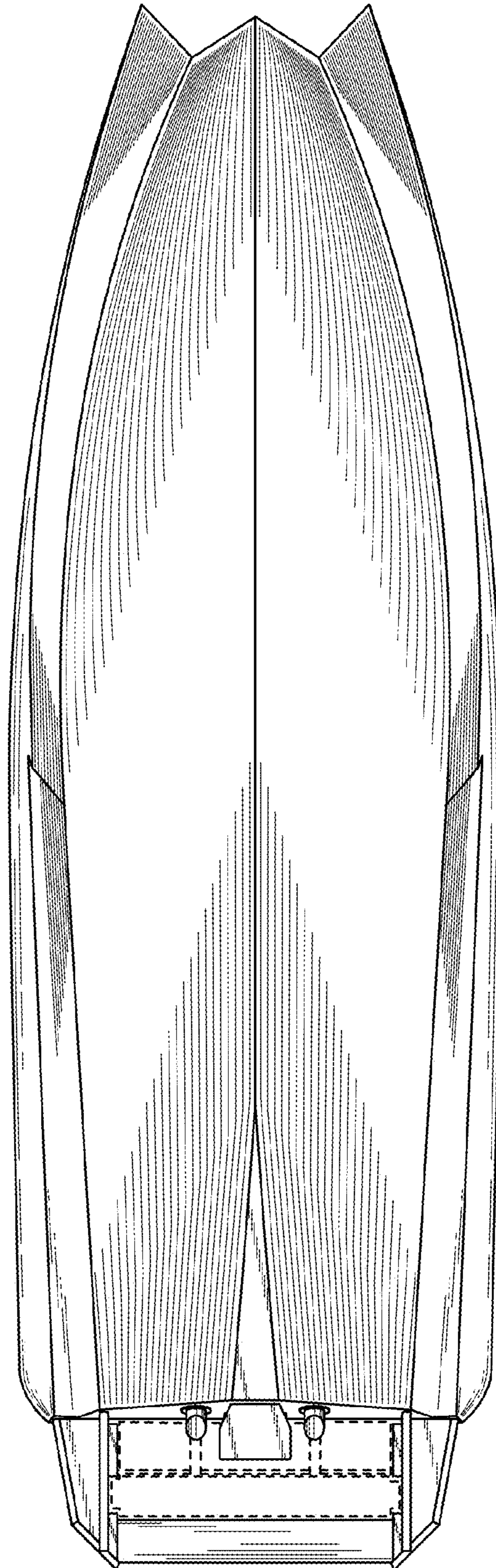

FIG. 7

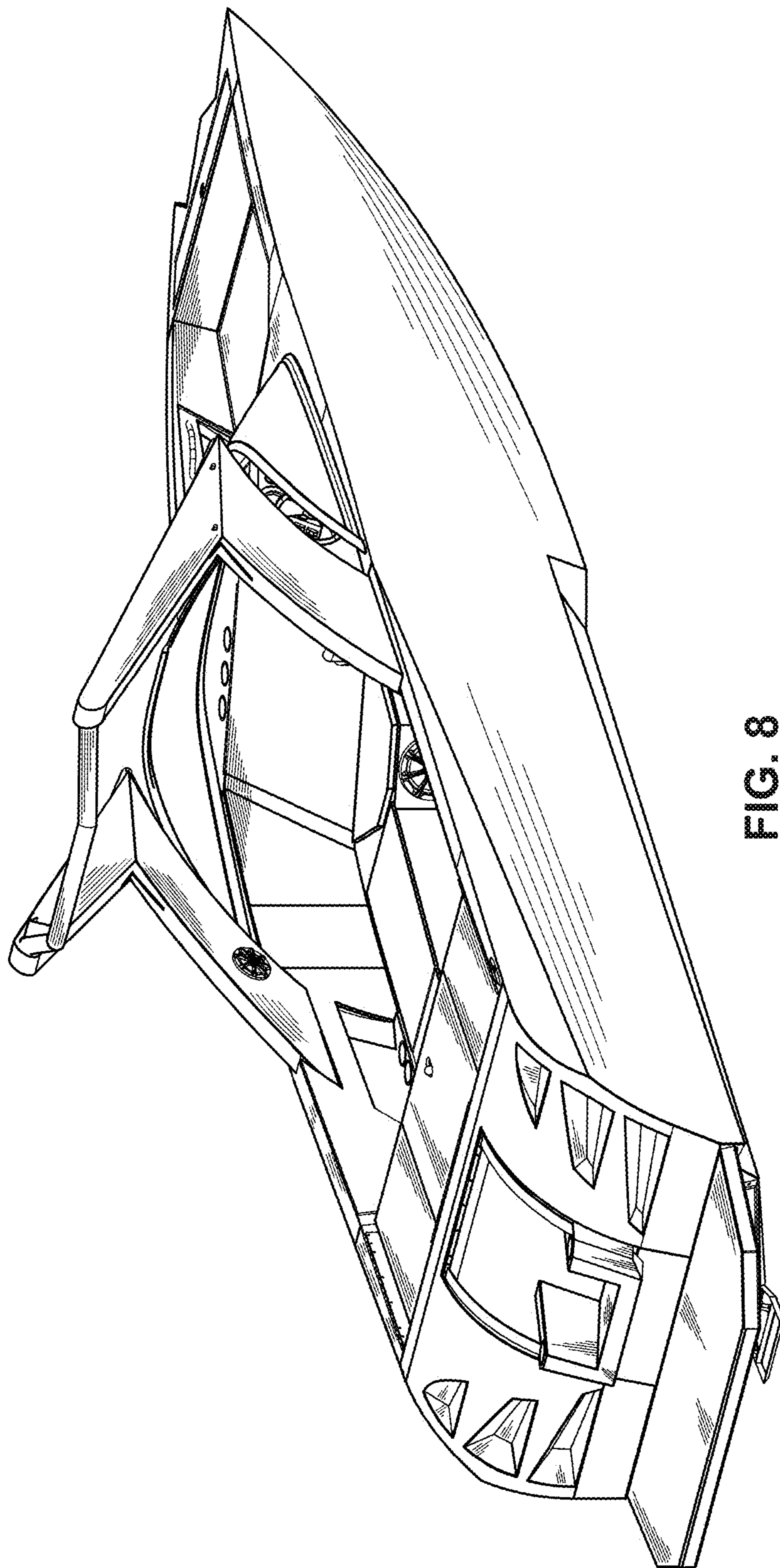

FIG. 8