



US00D679032S

(12) **United States Design Patent**
Voelkerding et al.

(10) **Patent No.:** **US D679,032 S**
(45) **Date of Patent:** **** Mar. 26, 2013**

(54) **FLANGE BEARING FROG CROSSING INTERSECTION CASTING**

(75) Inventors: **Daniel Voelkerding**, Lakewood, OH (US); **James A. Remington**, Sheffield Village, OH (US)

(73) Assignee: **Cleveland Track Material, Inc.**, Cleveland, OH (US)

(**) Term: **14 Years**

(21) Appl. No.: **29/401,700**

(22) Filed: **Sep. 14, 2011**

(51) **LOC (9) Cl.** **25-99**

(52) **U.S. Cl.** **D25/199**

(58) **Field of Classification Search** D25/199;
246/463, 468, 454, 458, 473.1, 452

See application file for complete search history.

(56) **References Cited**

U.S. PATENT DOCUMENTS

1,833,063	A *	11/1931	Balkwill	246/463
3,910,534	A *	10/1975	Perrot	246/468
4,342,593	A *	8/1982	Larson et al.	420/73
4,362,282	A *	12/1982	Frank	246/468
5,598,993	A *	2/1997	Kuhn et al.	246/468
D505,737	S *	5/2005	Beranek et al.	D25/199
D510,775	S *	10/2005	Stegmeier	D25/199

* cited by examiner

Primary Examiner — Doris Clark

(74) *Attorney, Agent, or Firm* — Roger A. Gilcrest

(57) **CLAIM**

The ornamental design for a flange bearing frog crossing intersection casting, as shown and described.

DESCRIPTION

FIG. 1 is a top plan view of the subject flange bearing frog crossing intersection casting;

FIG. 2 is a bottom plan view of the subject flange bearing frog crossing intersection casting which is shown in phantom for context only, and forms no part of the claimed design;

FIG. 3 is a top upper right perspective view of FIG. 1;

FIG. 4 is a top lower left perspective view of FIG. 1;

FIG. 5 is an end view looking from the upper end of FIG. 1;

FIG. 6 is an end view looking from the left end of FIG. 1;

FIG. 7 is an end view looking from the lower end of FIG. 1;

FIG. 8 is top lower right perspective view of FIG. 1;

FIG. 9 is a top upper left perspective view of FIG. 1;

FIG. 10 is an end view looking towards the upper right corner of FIG. 1;

FIG. 11 is an end view looking towards the lower left corner of FIG. 1;

FIG. 12 is an end view looking towards the lower right corner of FIG. 1; and,

FIG. 13 is an end view looking towards the upper left corner of FIG. 1.

The lettering on the upper surface of the flange bearing frog crossing intersection casting shown in FIGS. 3 and 4 forms no part of the claimed design.

1 Claim, 13 Drawing Sheets

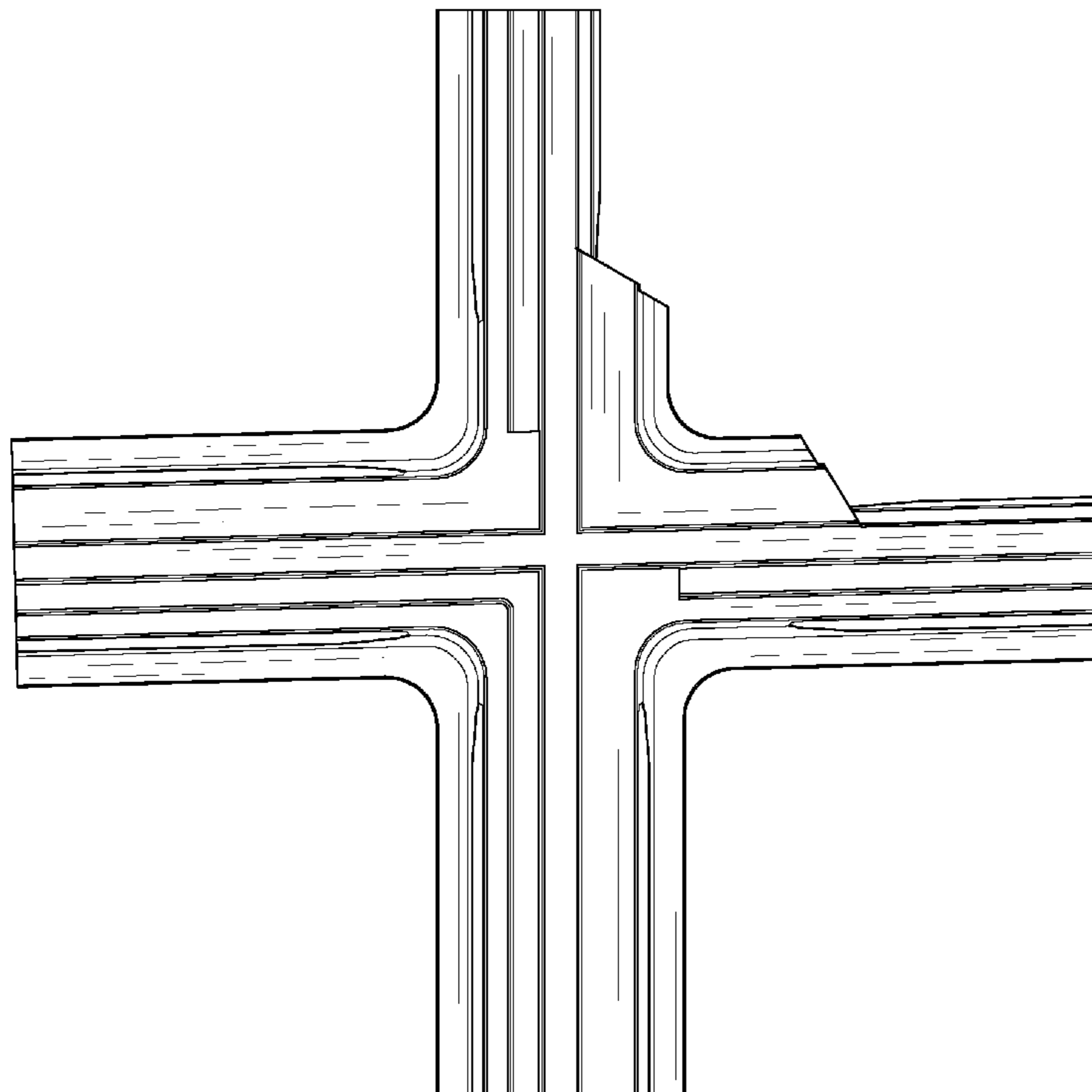

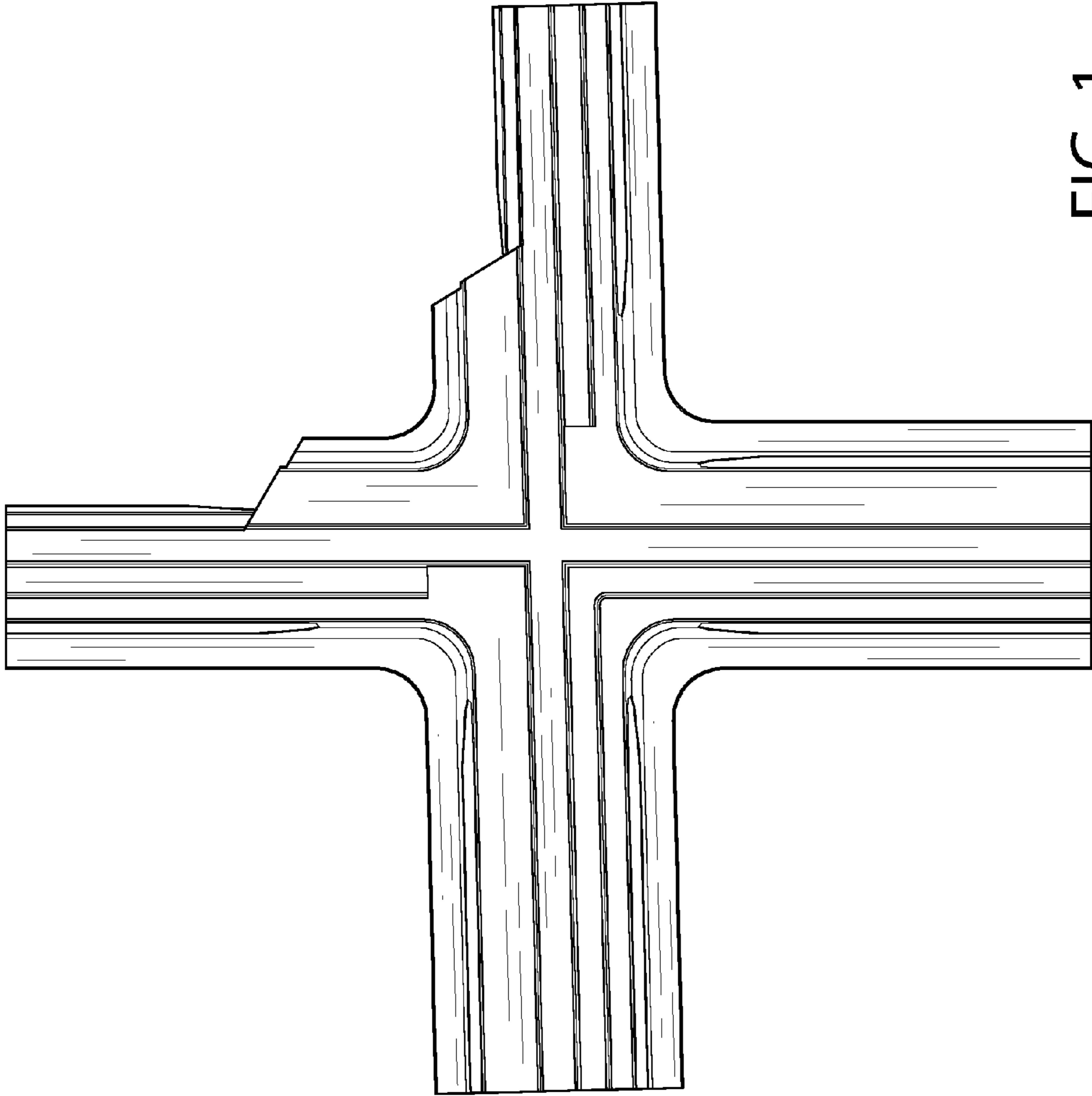

FIG. 1

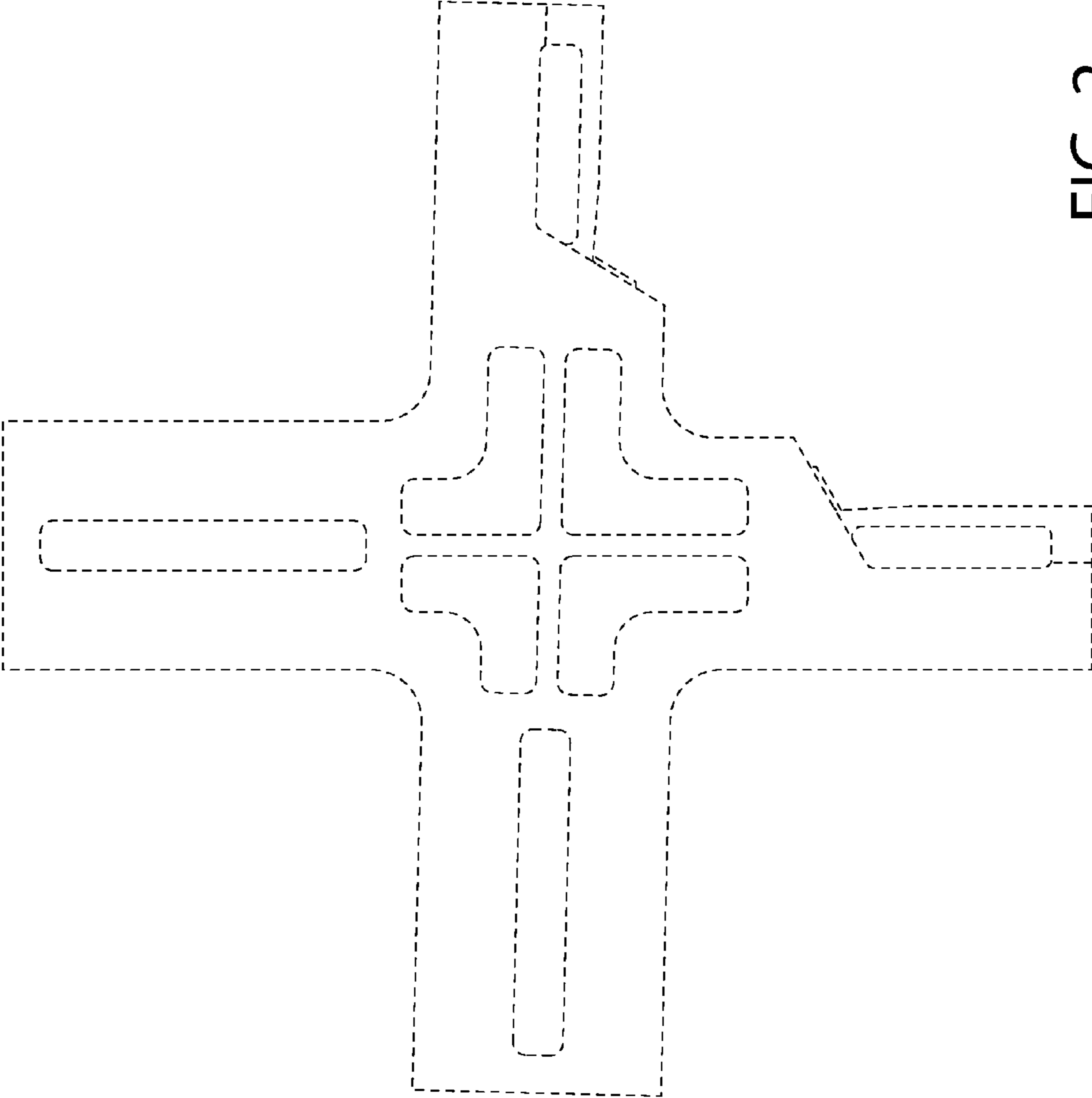

FIG. 2

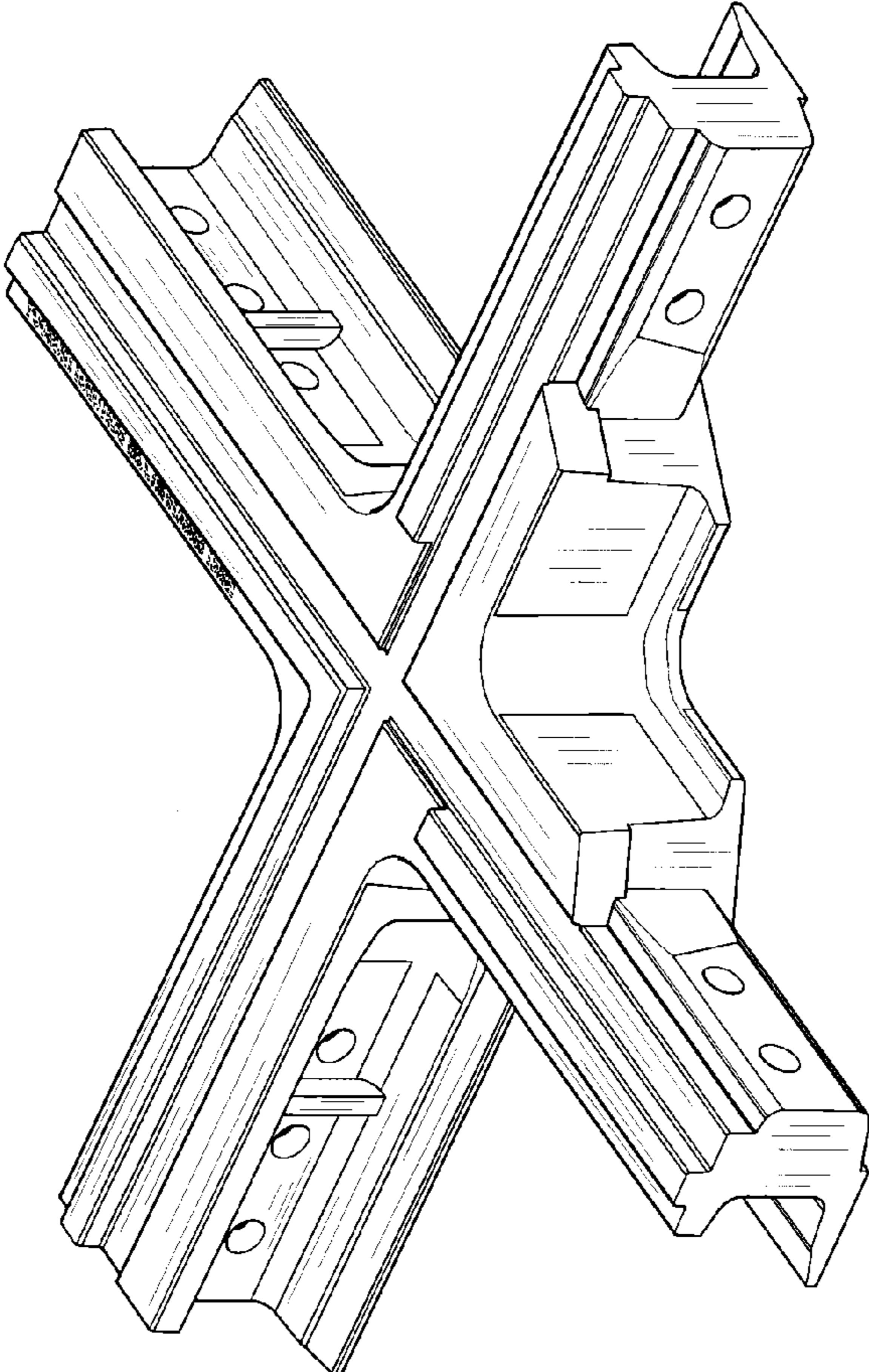

FIG. 3

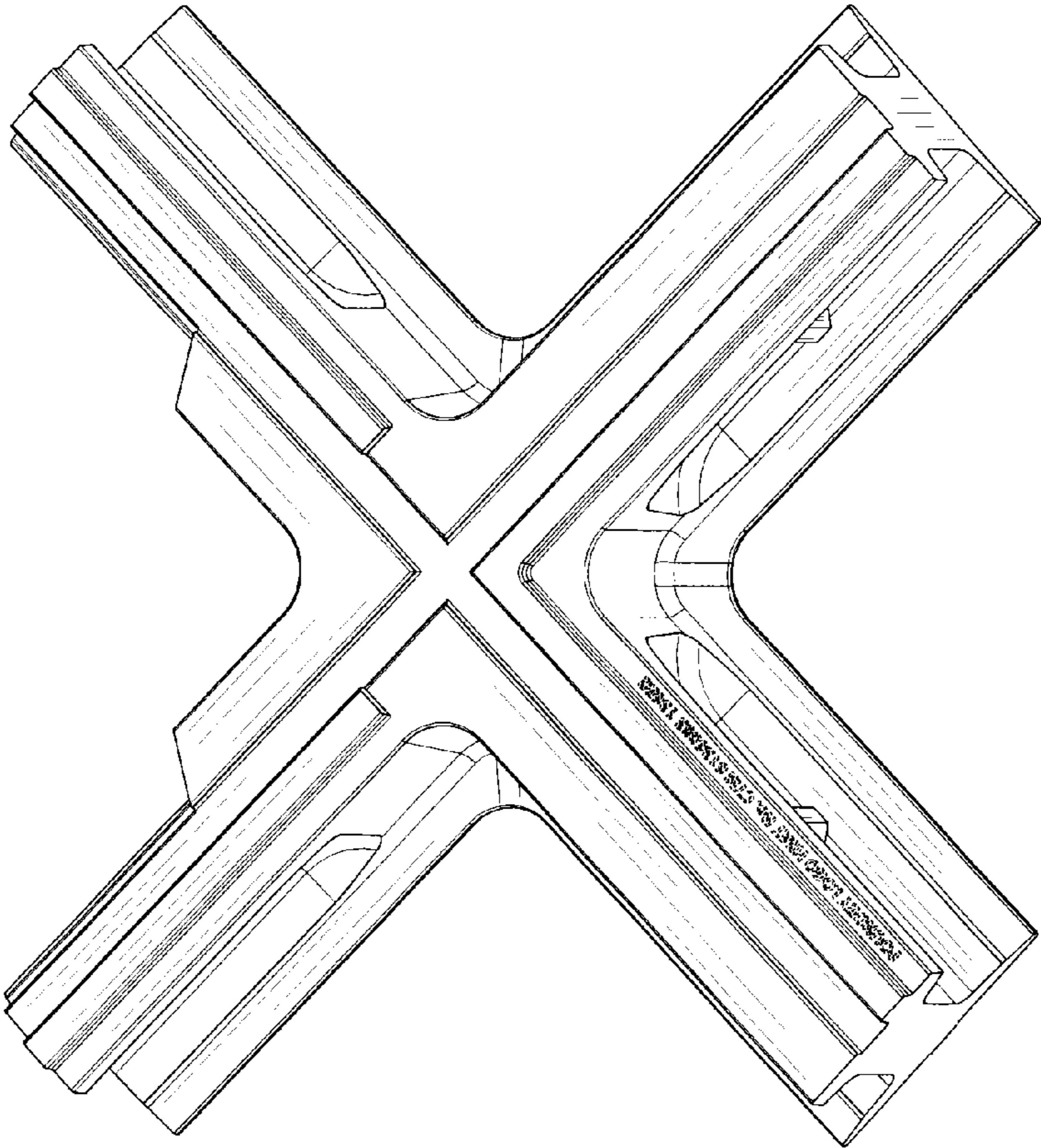

FIG. 4

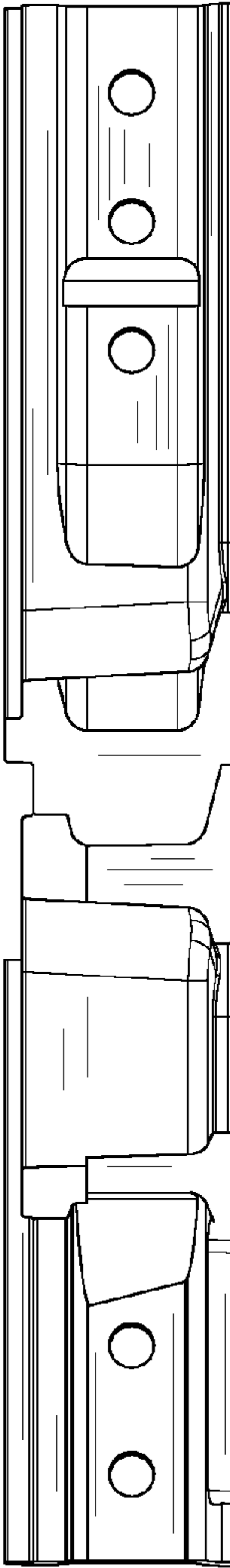

FIG. 5

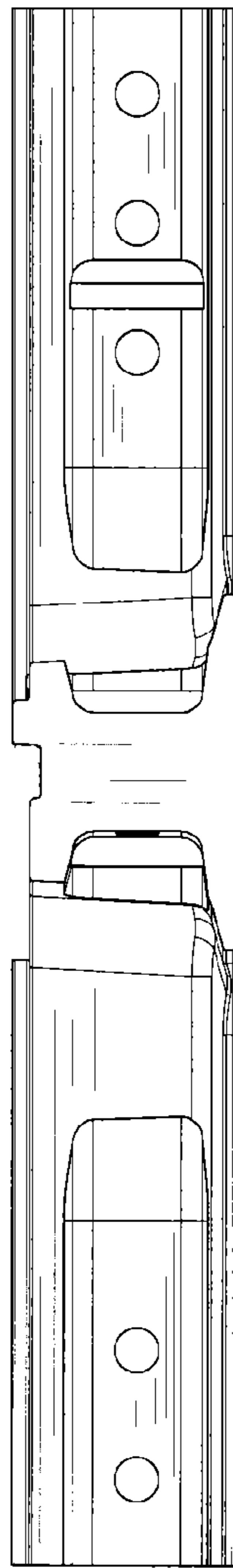

FIG. 6

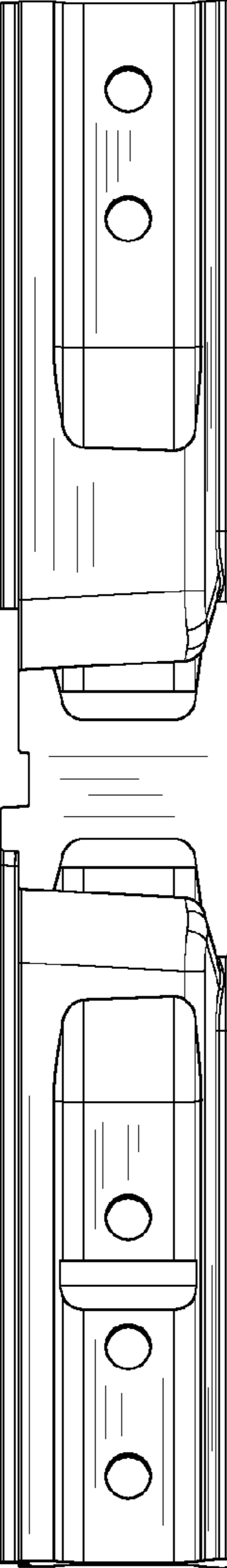

FIG. 7

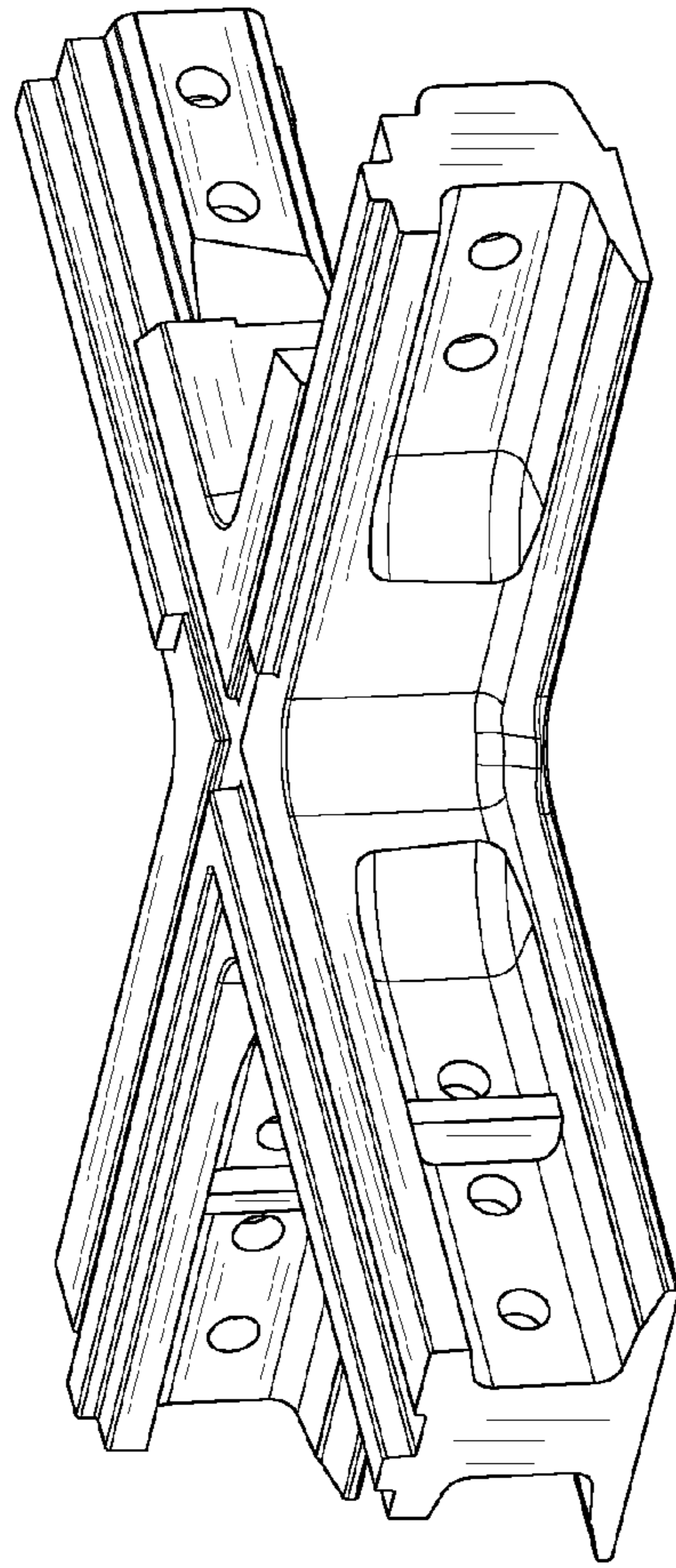

FIG. 8

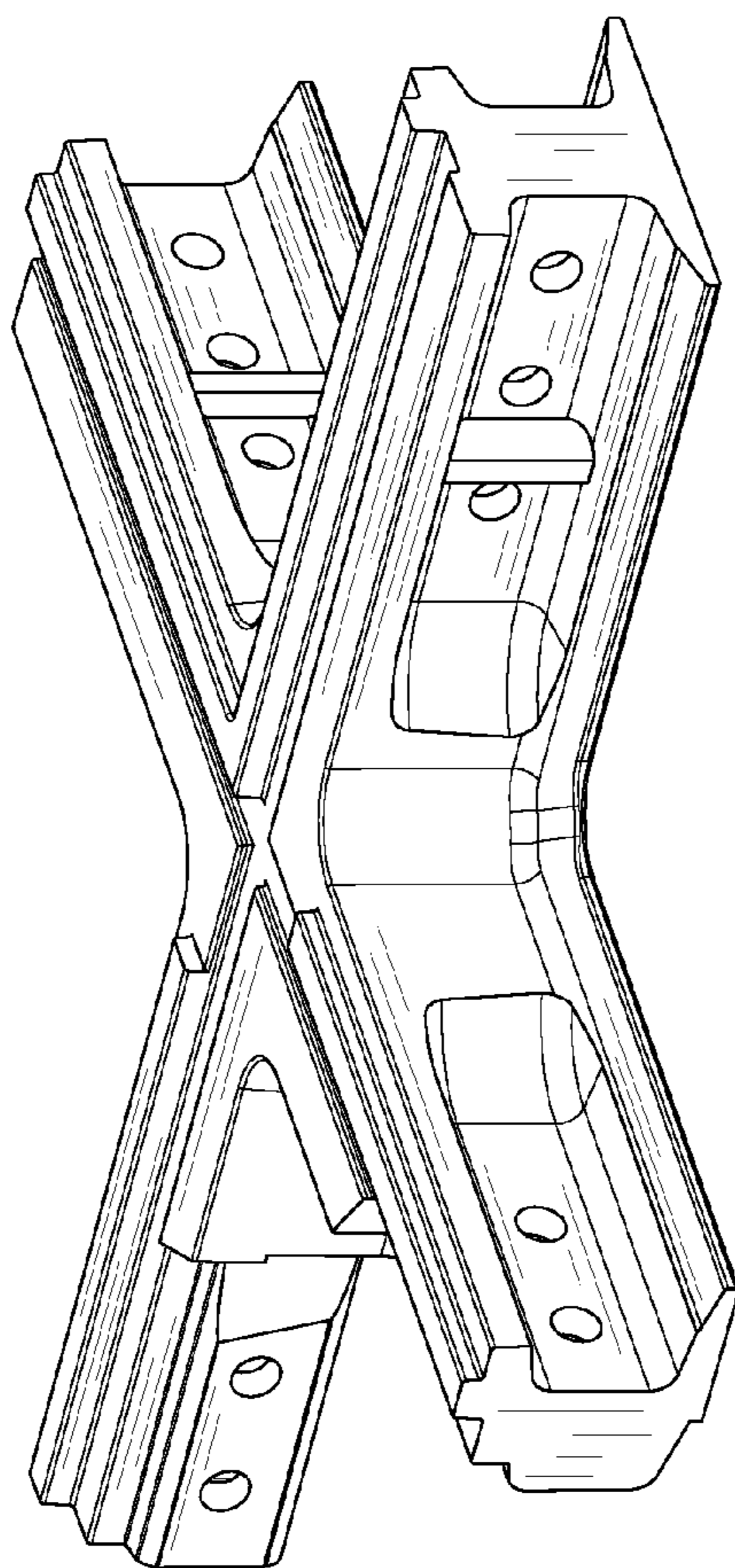

FIG. 9

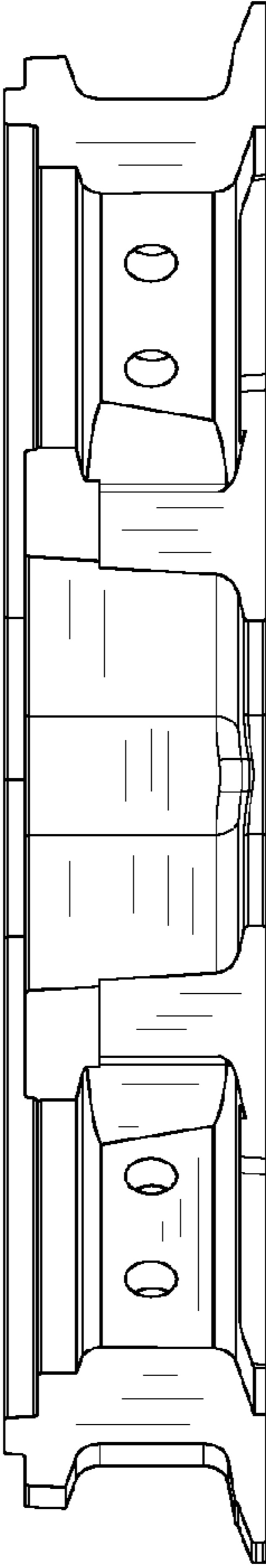

FIG. 10

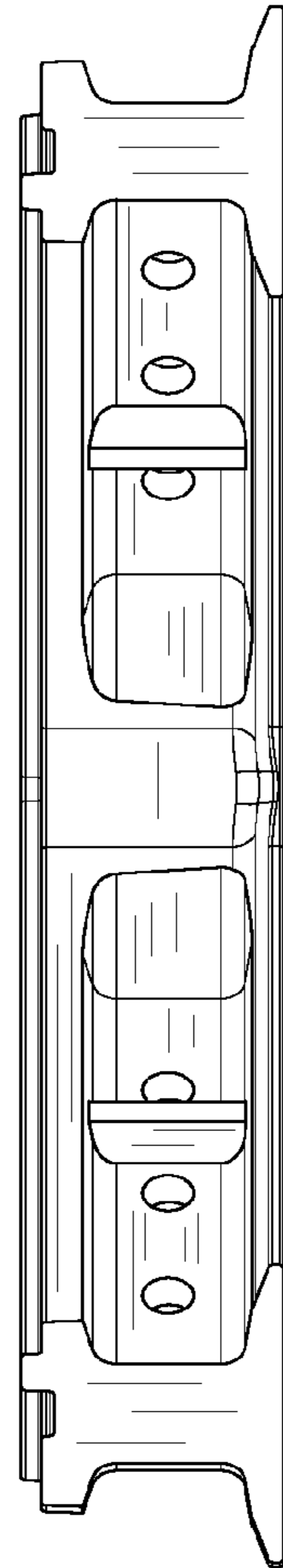

FIG. 11

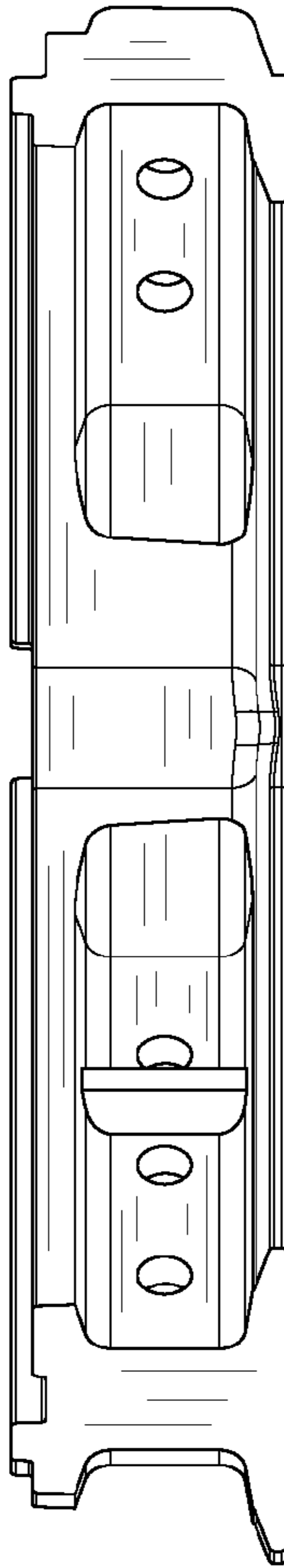

FIG. 12

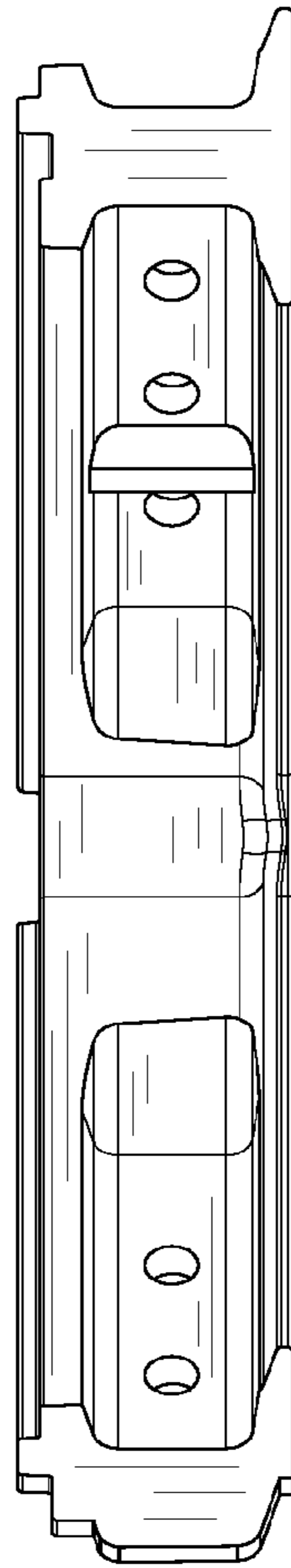

FIG. 13