



US00D679028S

(12) **United States Design Patent**
Tipton

(10) **Patent No.:** **US D679,028 S**

(45) **Date of Patent:** **** Mar. 26, 2013**

(54) **PIPE ANCHOR BLOCK**

(76) Inventor: **Daron R. Tipton**, Benson, AZ (US)

(**) Term: **14 Years**

(21) Appl. No.: **29/389,127**

(22) Filed: **Apr. 6, 2011**

(51) **LOC (9) Cl.** **25-01**

(52) **U.S. Cl.** **D25/113**

(58) **Field of Classification Search** D25/102-118,
D25/136, 138, 140, 151, 152, 153, 156-162,
D25/164; D21/484-491, 499-504; 405/16,
405/284, 286; 52/503-505, 574, 575, 596-612;
404/27-42; D23/266; D8/380; 248/56,
248/62

See application file for complete search history.

(56) **References Cited**

U.S. PATENT DOCUMENTS

4,222,538 A * 9/1980 Jensen et al. 248/56
D257,397 S * 10/1980 Gustafsson D25/141
D302,045 S * 7/1989 Gazley D25/113
D367,329 S * 2/1996 Nelson et al. D25/118
D403,412 S * 12/1998 McMahon et al. D23/266

5,852,906 A * 12/1998 Kuban 52/607
D481,135 S * 10/2003 Dean et al. D25/113
D590,926 S * 4/2009 Crain D23/266
D621,071 S * 8/2010 Elliott D25/113
D627,212 S * 11/2010 Hikoyama D8/380
D634,447 S * 3/2011 Elliott D25/113
2005/0252146 A1 * 11/2005 MacDonald et al. 52/606

* cited by examiner

Primary Examiner — Anhdao Doan

(74) *Attorney, Agent, or Firm* — Dale F. Regelman; Quarles & Brady LLP

(57) **CLAIM**

The ornamental design for a pipe anchor block, as shown and described.

DESCRIPTION

FIG. 1 is a perspective view of the design of this invention;
FIG. 2 is a first side view thereof;
FIG. 3 is a second side view thereof;
FIG. 4 is a front view thereof;
FIG. 5 is a back view thereof;
FIG. 6 is a top view thereof; and,
FIG. 7 is a bottom view thereof.

1 Claim, 4 Drawing Sheets

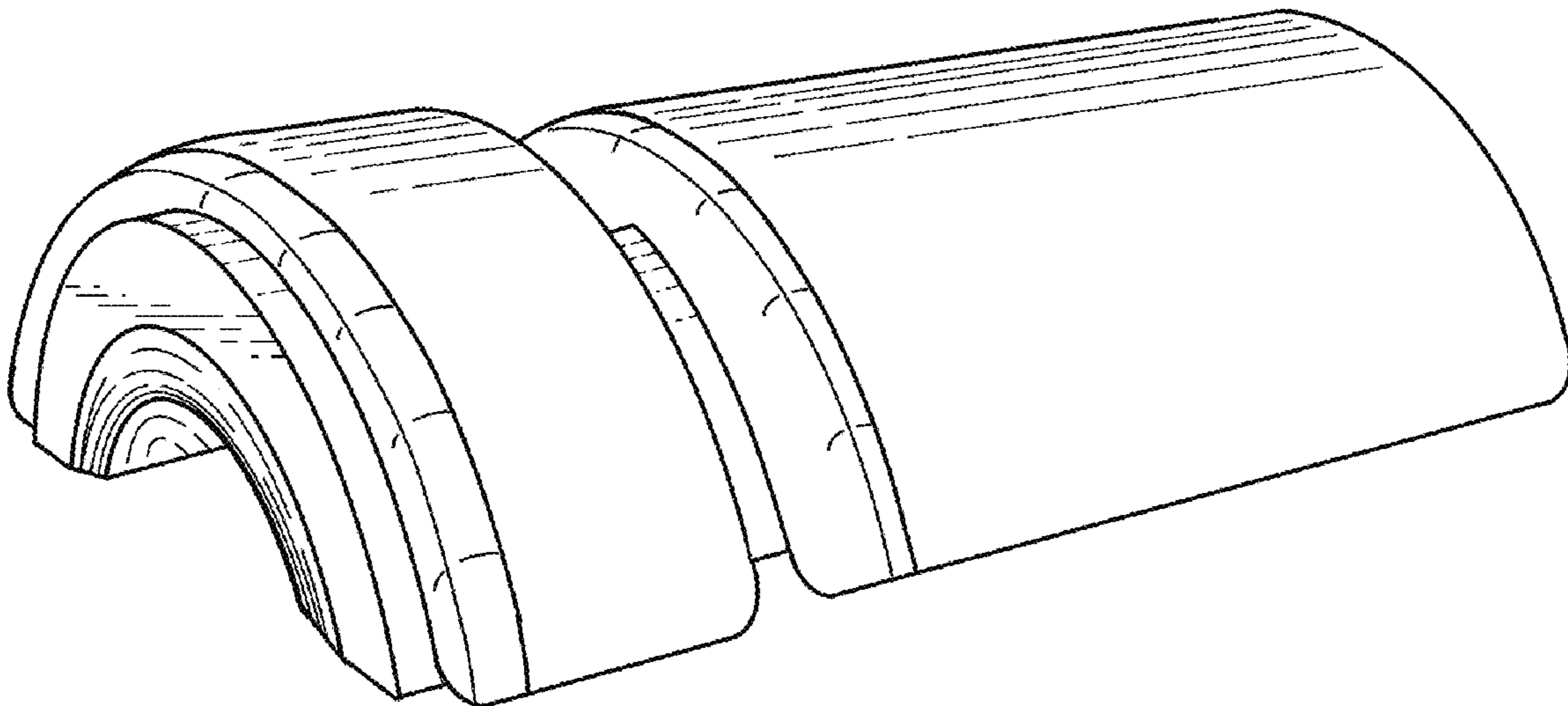

FIG. 1

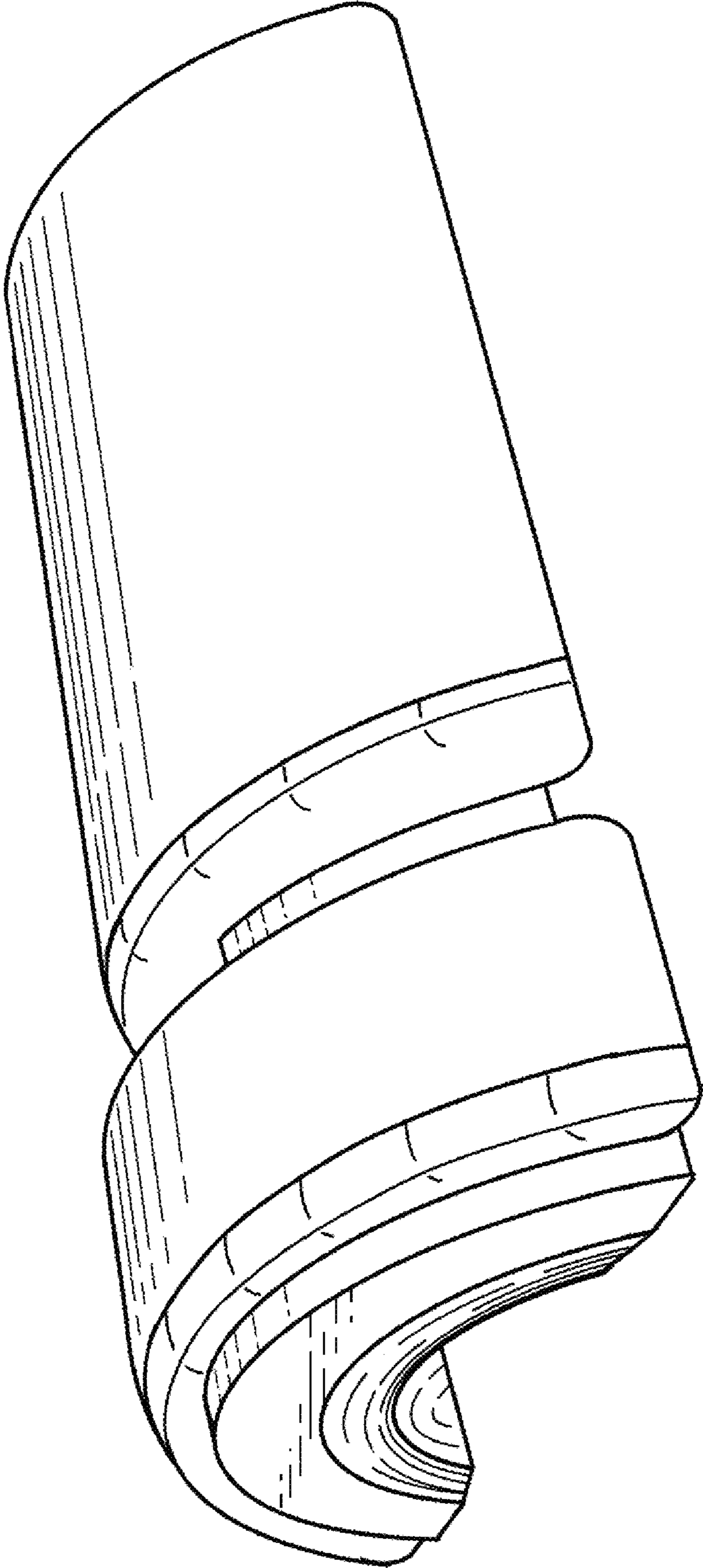

FIG. 2

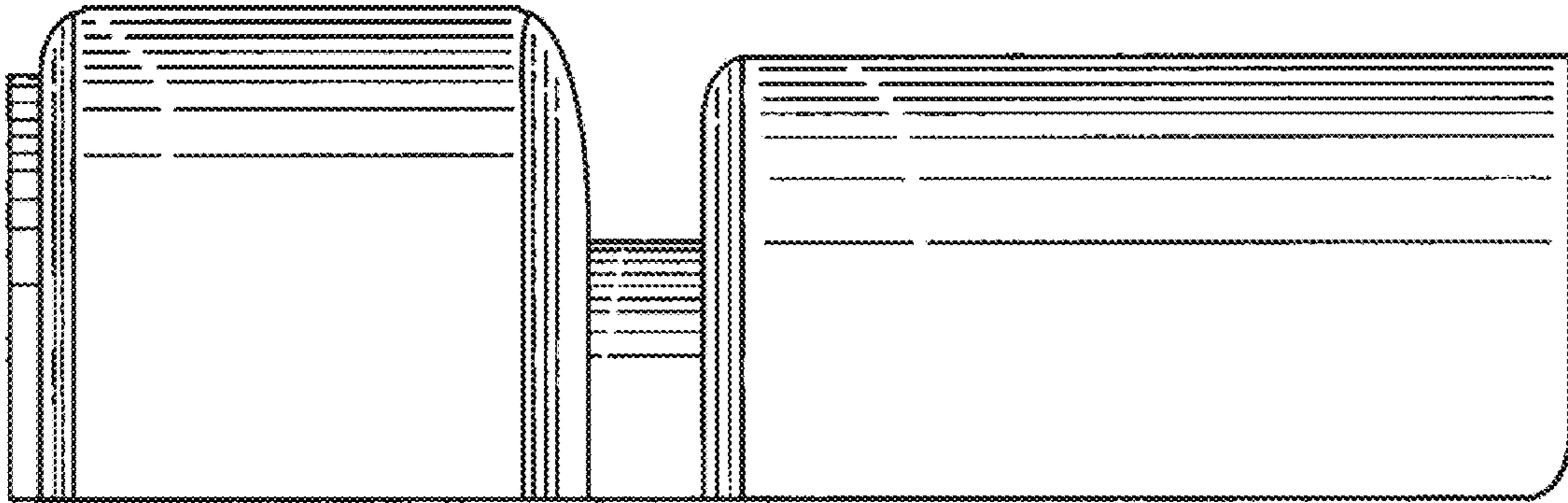

FIG. 3

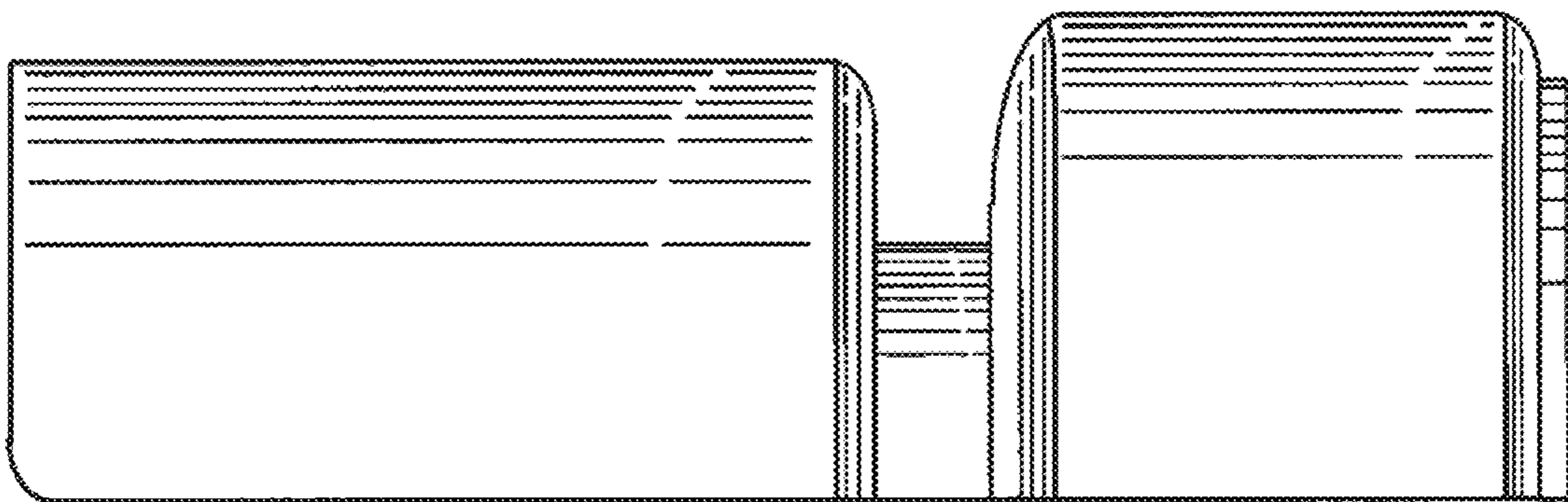

FIG. 4

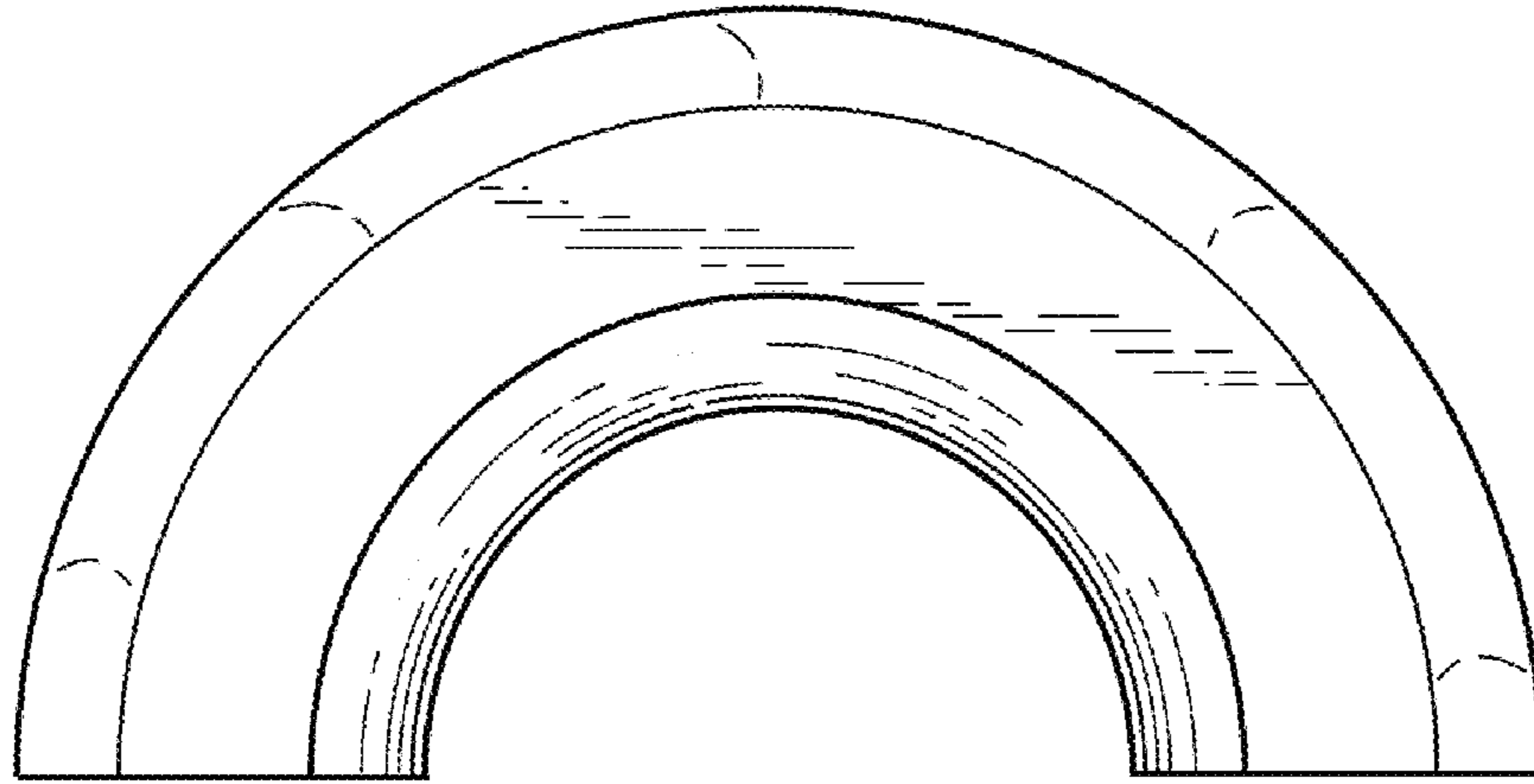

FIG. 5

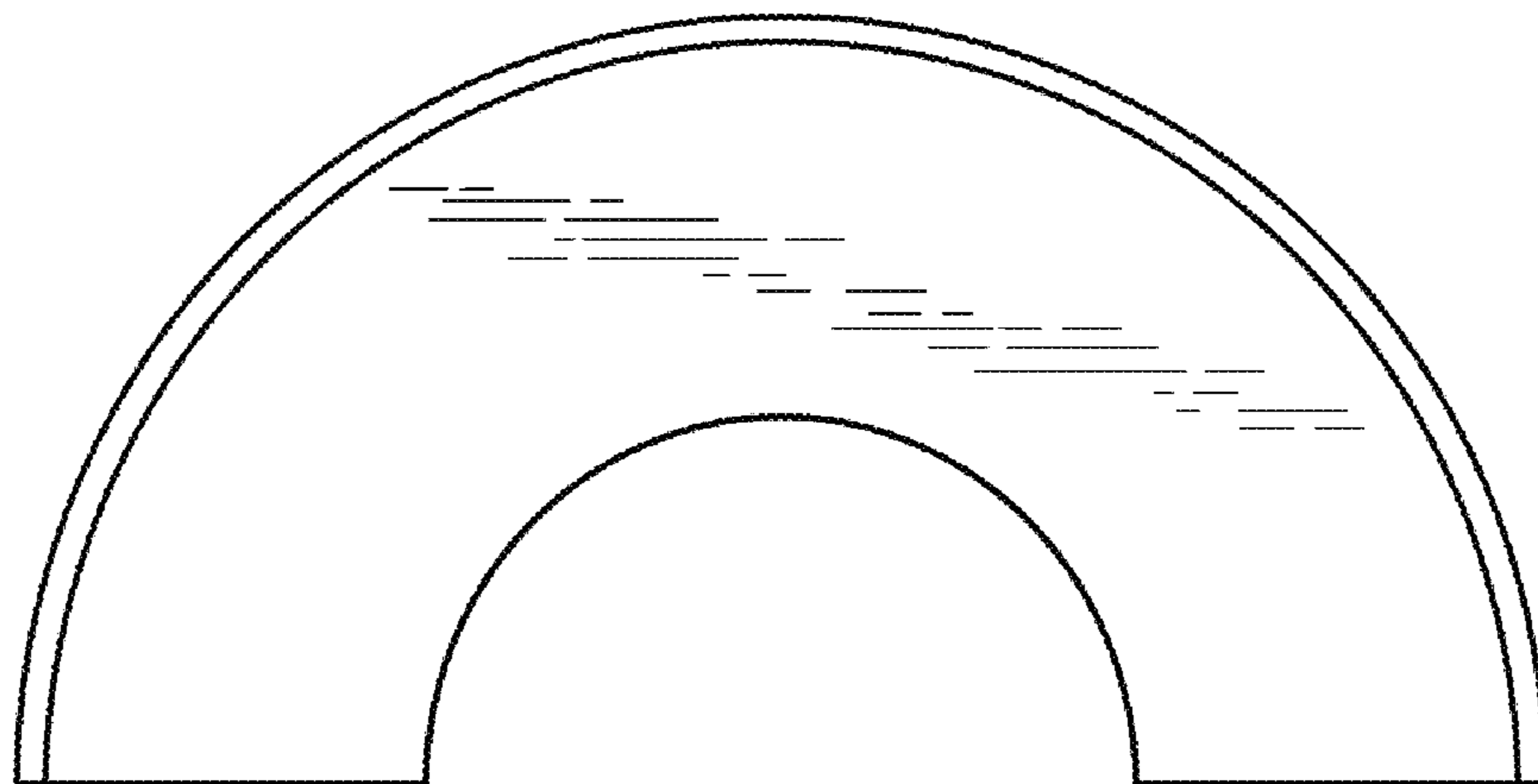

FIG. 6

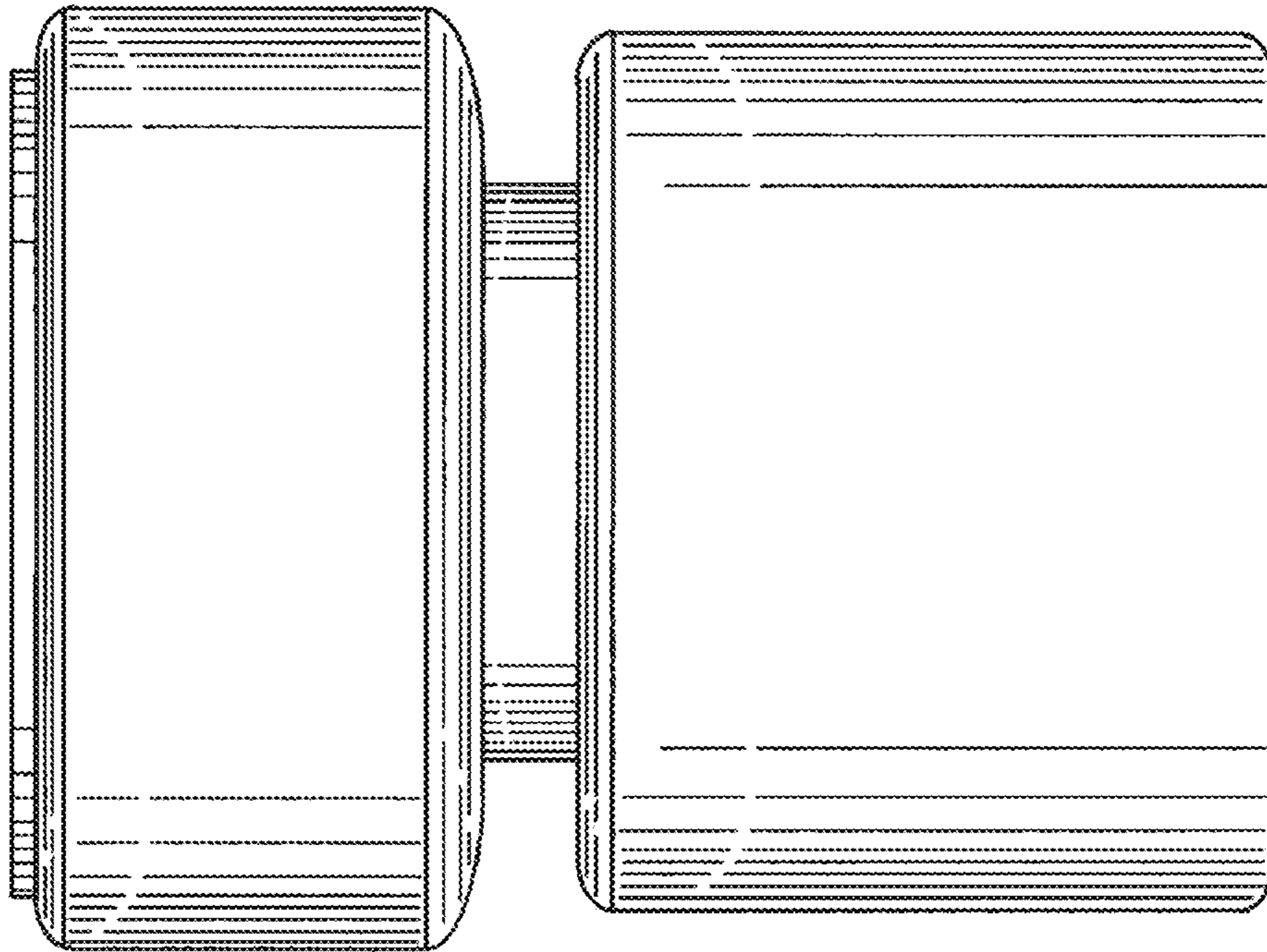

FIG. 7

