



US00D678954S

(12) **United States Design Patent**
Young et al.

(10) **Patent No.:** **US D678,954 S**
(45) **Date of Patent:** **** Mar. 26, 2013**

(54) **LENS ACCESSORY FOR VIDEO GAME
SENSOR DEVICE**

D665,461 S * 8/2012 Ikeda et al. D21/333
8,270,827 B2 * 9/2012 Tse, Jr. 396/544
8,314,923 B2 * 11/2012 York et al. 356/4.01

(75) Inventors: **Allen Richard Young**, Los Angeles, CA
(US); **Herschel Naghi**, Beverly Hills,
CA (US)

* cited by examiner

(73) Assignee: **Nyko Technologies, Inc.**, Los Angeles,
CA (US)

Primary Examiner — Prabhakar Deshmukh

(74) *Attorney, Agent, or Firm* — Christie, Parker & Hale,
LLP

(**) Term: **14 Years**

(57) **CLAIM**

The ornamental design for lens accessory for video game
sensor device, as shown and described.

(21) Appl. No.: **29/394,811**

DESCRIPTION

(22) Filed: **Jun. 21, 2011**

Related U.S. Application Data

(63) Continuation of application No. 13/153,341, filed on
Jun. 3, 2011, now Pat. No. 8,123,622.

(51) **LOC (9) Cl.** **21-01**

(52) **U.S. Cl.** **D21/333; D21/328**

(58) **Field of Classification Search** D21/330,
D21/324, 328, 332, 333; 463/1, 36, 46, 47;
356/4.01; 348/222.1, 335, 46
See application file for complete search history.

FIG. 1 is a front perspective view thereof;

FIG. 2 is a front view thereof;

FIG. 3 is a side view thereof;

FIG. 4 is a rear view thereof;

FIG. 5 is a top view thereof;

FIG. 6 is a bottom view thereof;

FIG. 7 is a front perspective view of another embodiment
thereof, showing, for reference, a video game sensor device
coupled thereto;

FIG. 8 is a front view thereof, showing, for reference, a video
game sensor device coupled thereto;

FIG. 9 is a side view thereof, showing, for reference, a video
game sensor device coupled thereto;

FIG. 10 is a rear view thereof, showing, for reference, a video
game sensor device coupled thereto;

FIG. 11 is a top view thereof, showing, for reference, a video
game sensor device coupled thereto; and,

FIG. 12 is a bottom view thereof, showing, for reference, a
video game sensor device coupled thereto.

The broken lines are for illustrative purpose only and form no
part of the claimed design.

(56) **References Cited**

U.S. PATENT DOCUMENTS

D433,074 S * 10/2000 Clemmer D21/324
6,844,562 B2 * 1/2005 Takaoka et al. 250/559.38
6,972,787 B1 * 12/2005 Allen et al. 348/162
7,265,439 B1 * 9/2007 Wu et al. 257/678
D632,340 S * 2/2011 Guinchard et al. D21/333
7,889,324 B2 * 2/2011 Yamamoto 356/4.01
8,111,382 B2 * 2/2012 Wolf et al. 356/4.01
8,123,622 B1 * 2/2012 Young et al. 463/47

1 Claim, 12 Drawing Sheets

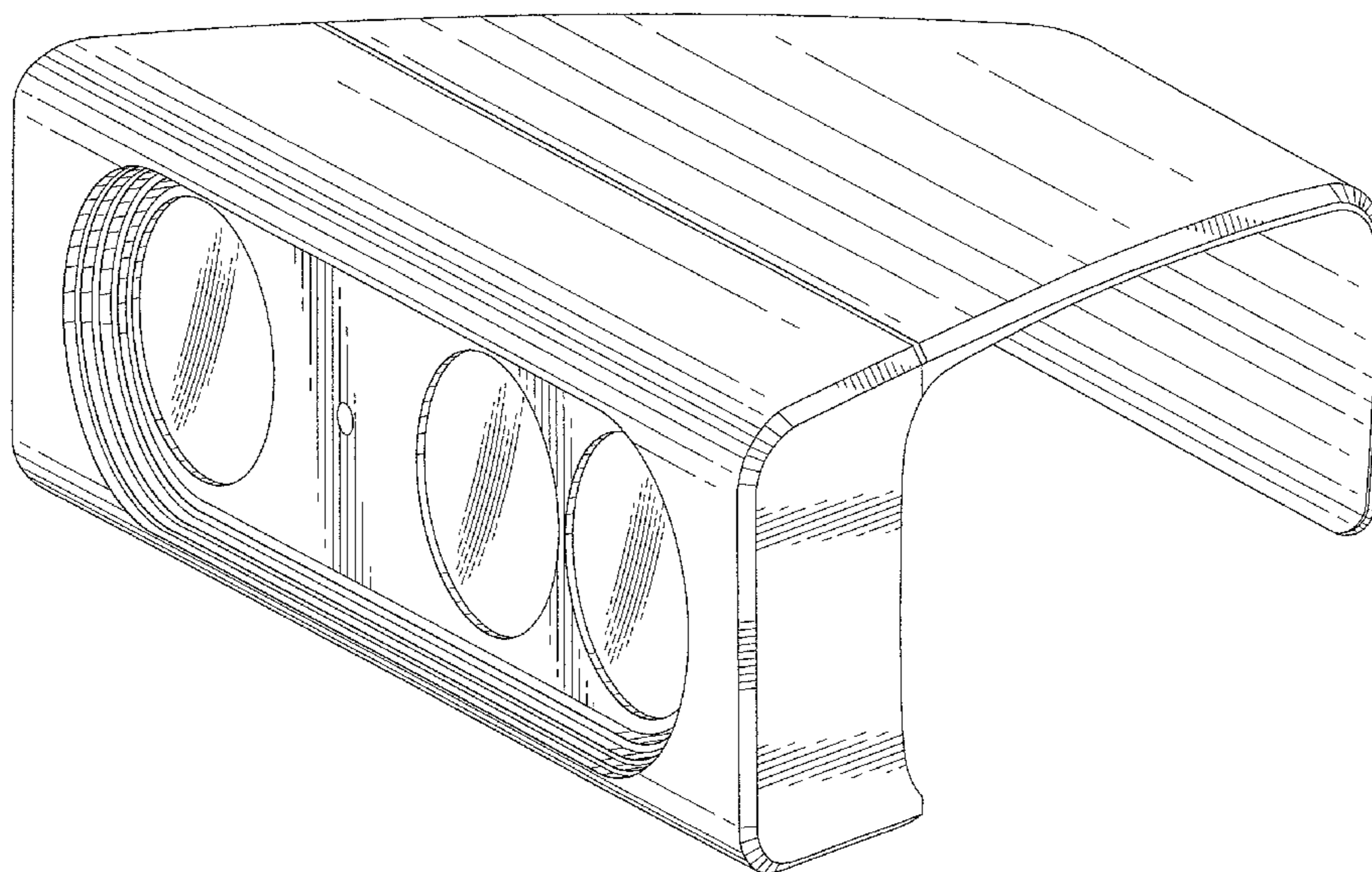

FIG. 1

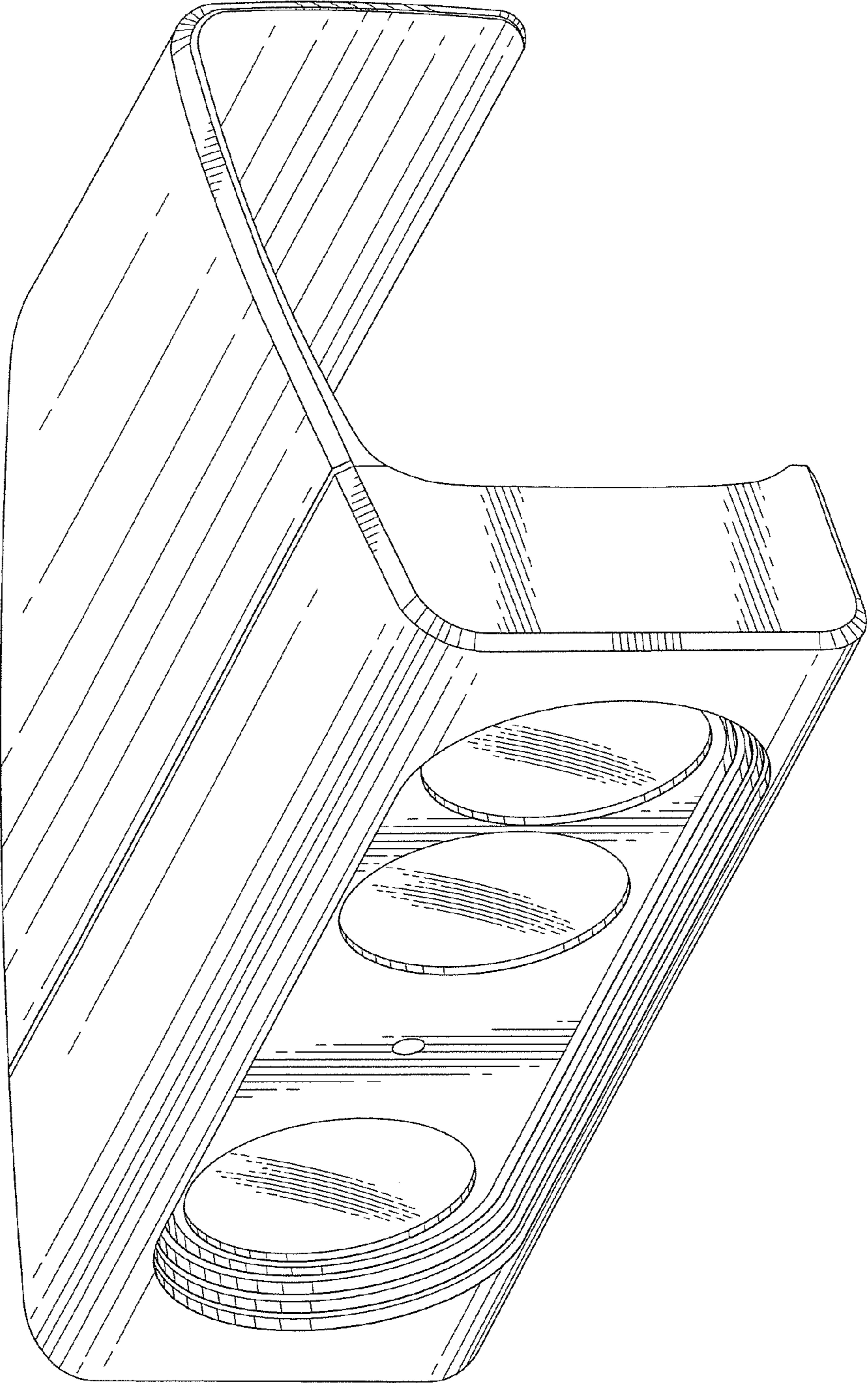

FIG. 2

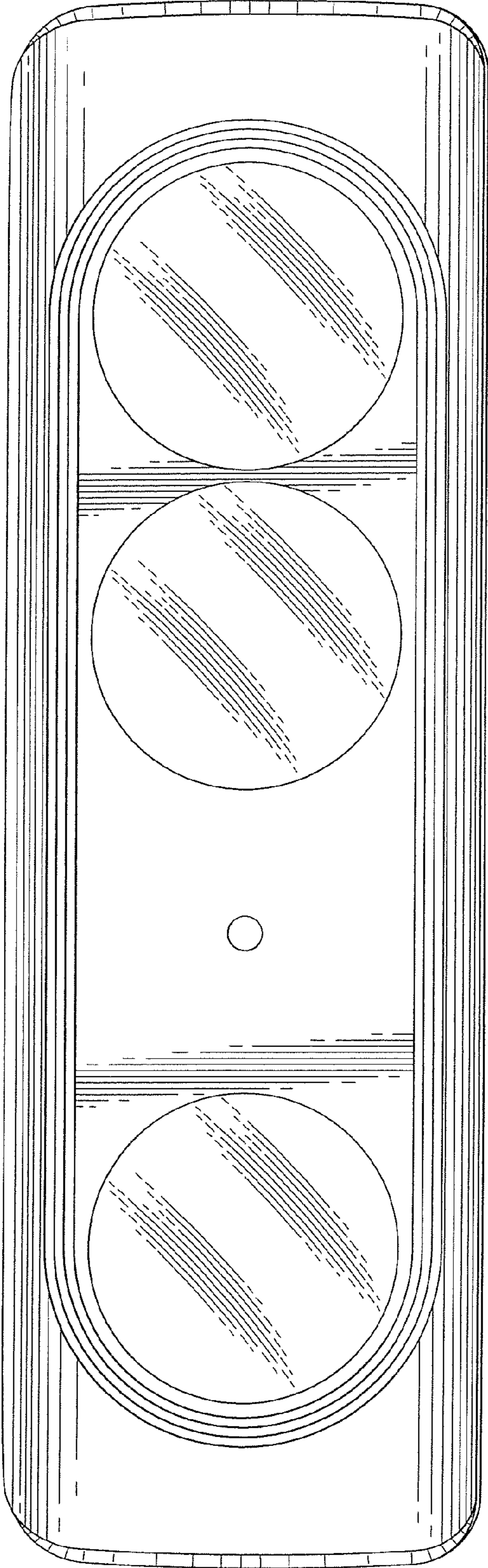

FIG. 3

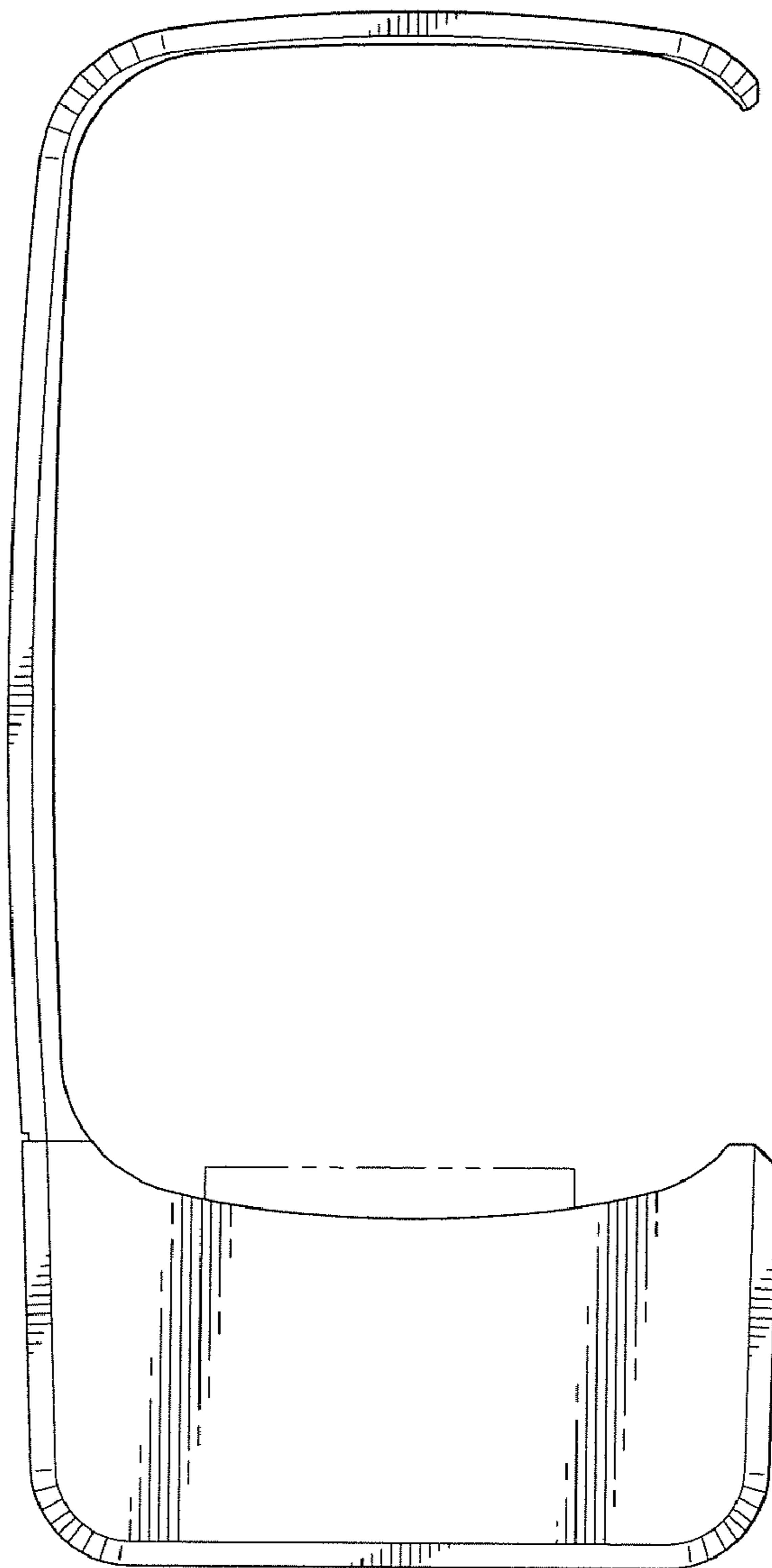

FIG. 4

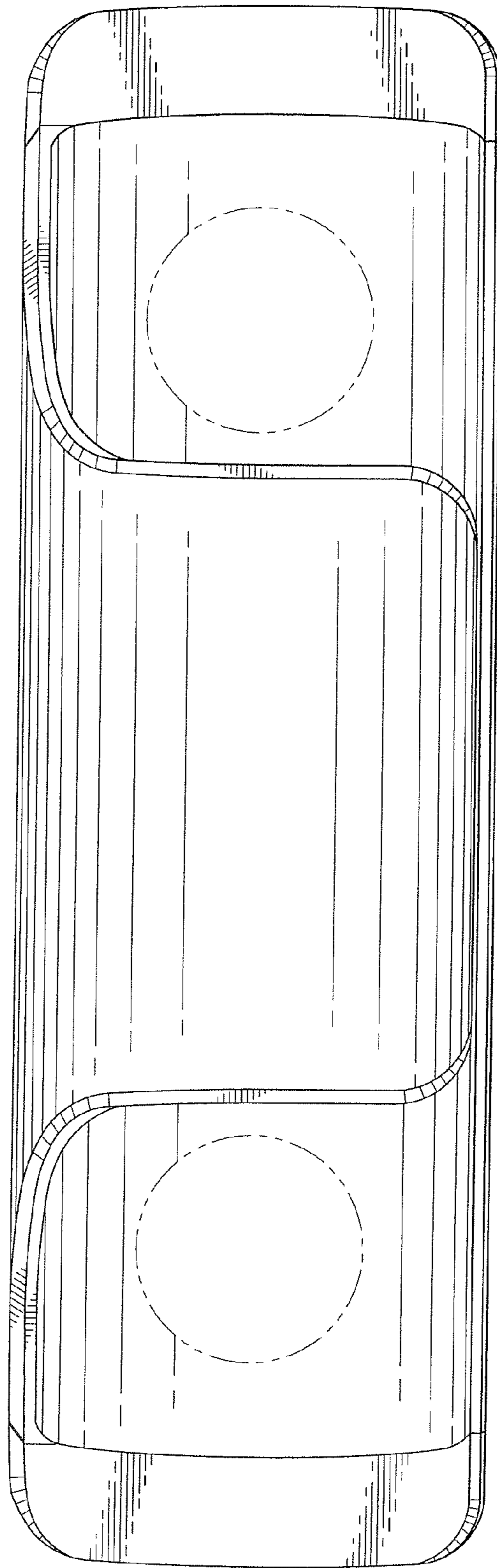

FIG. 5

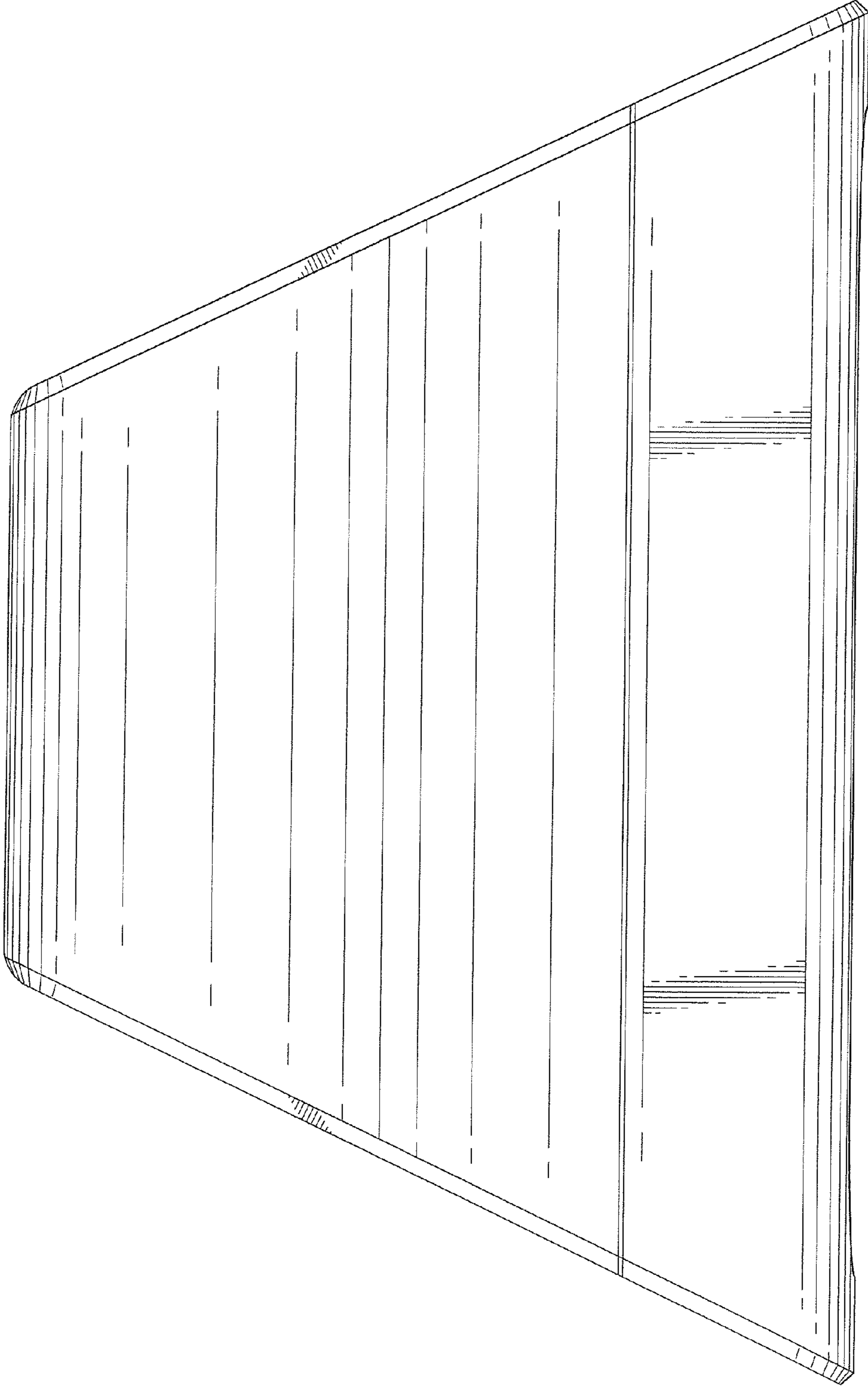

FIG. 6

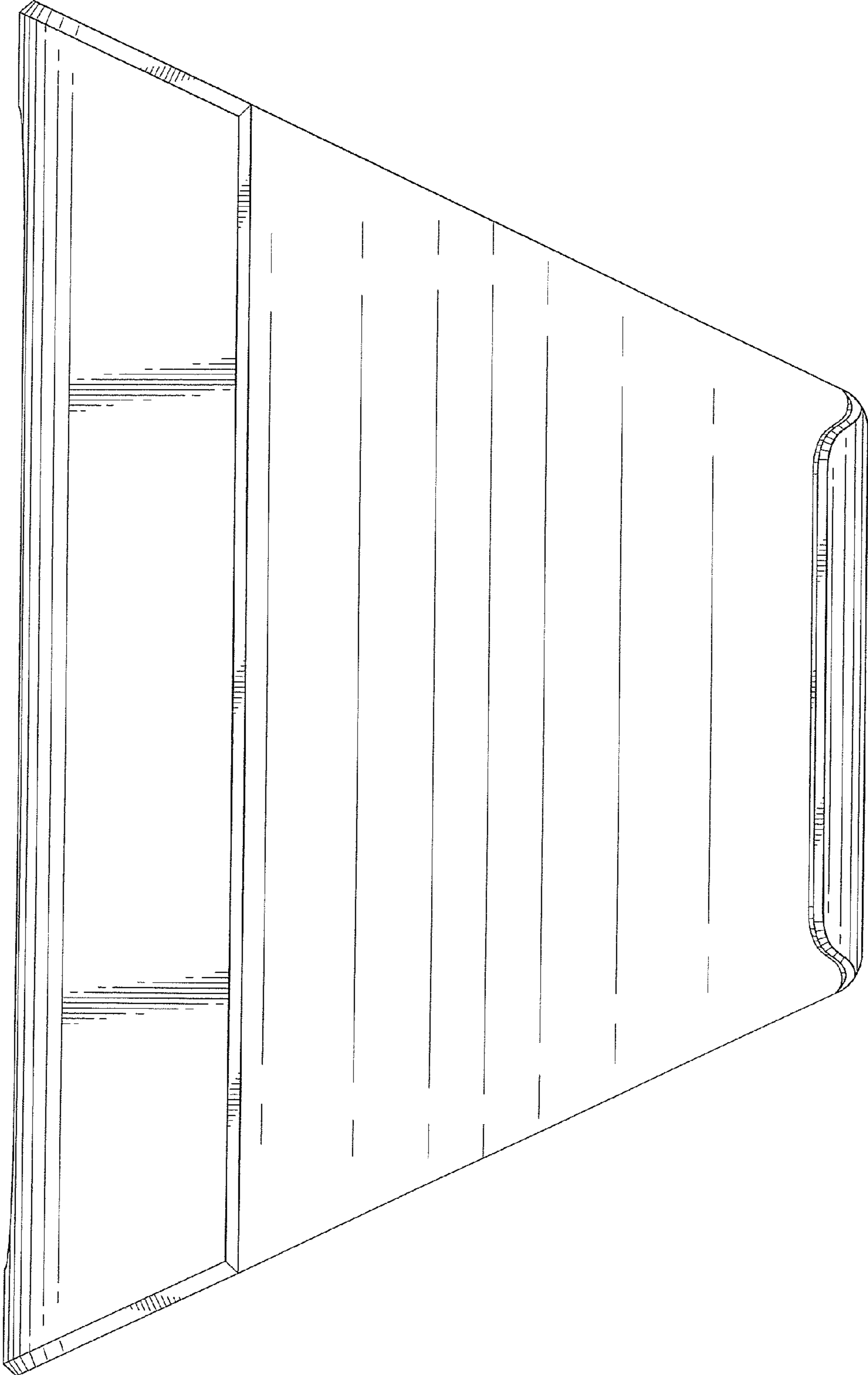

FIG. 7

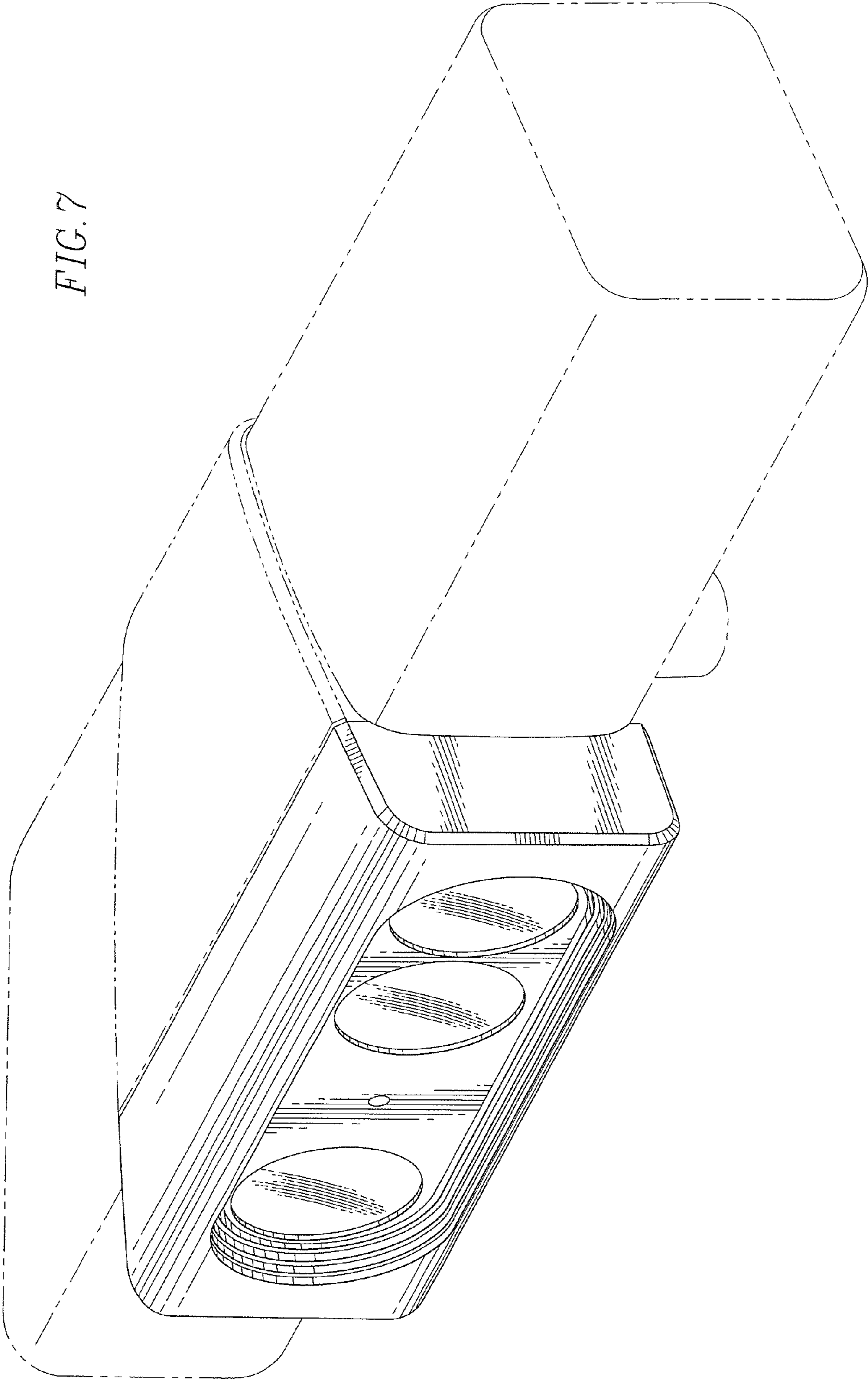

FIG. 8

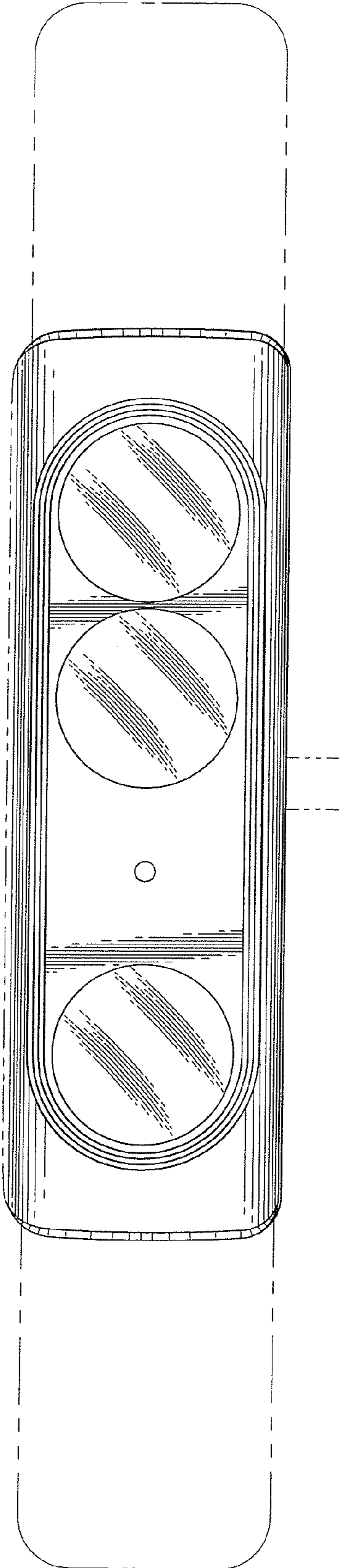

FIG. 9

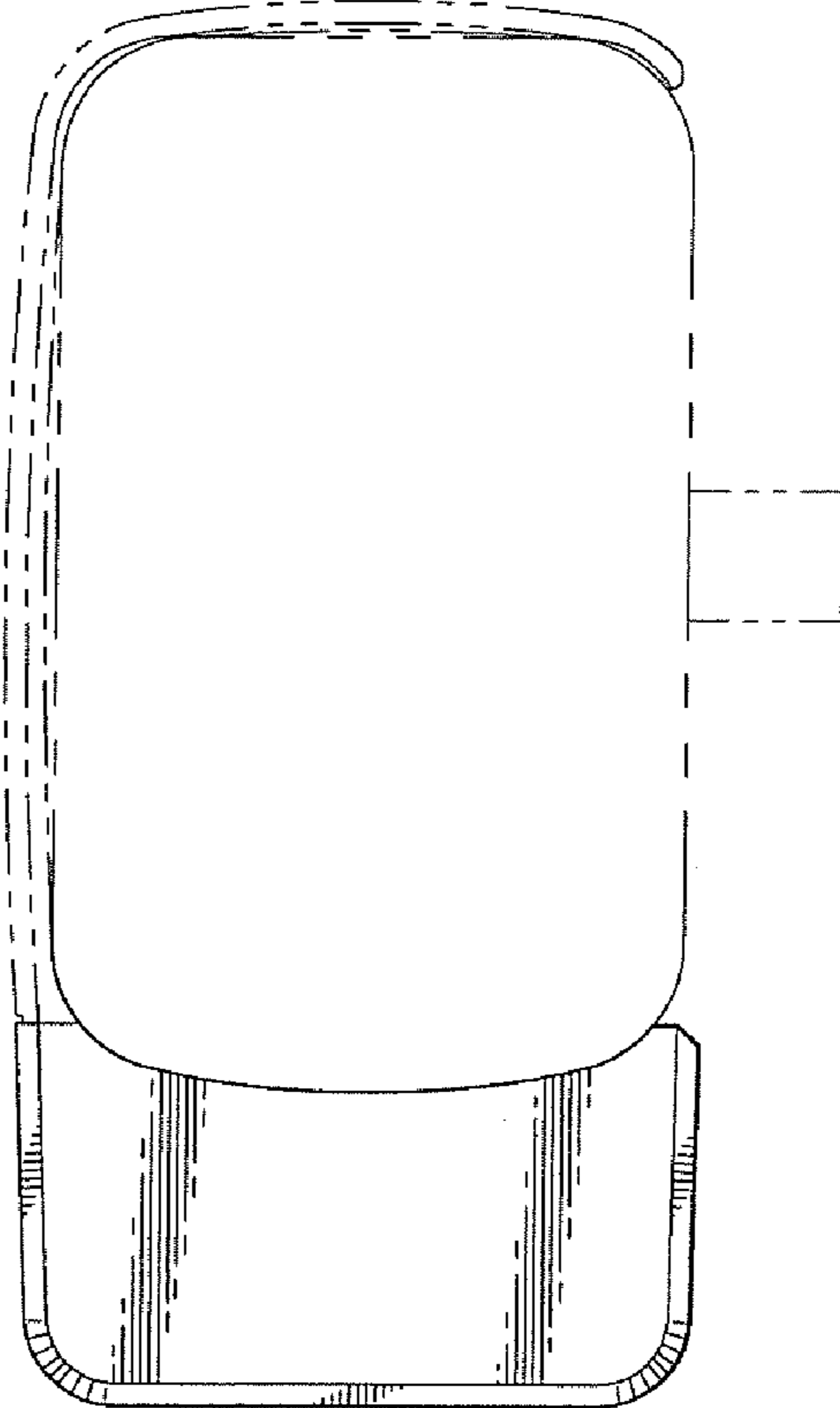

FIG. 10

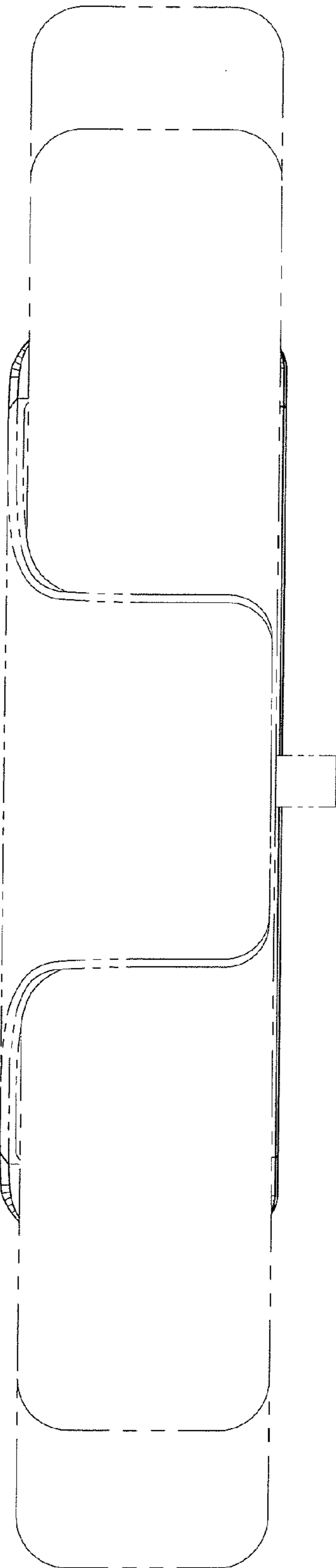

FIG. 11

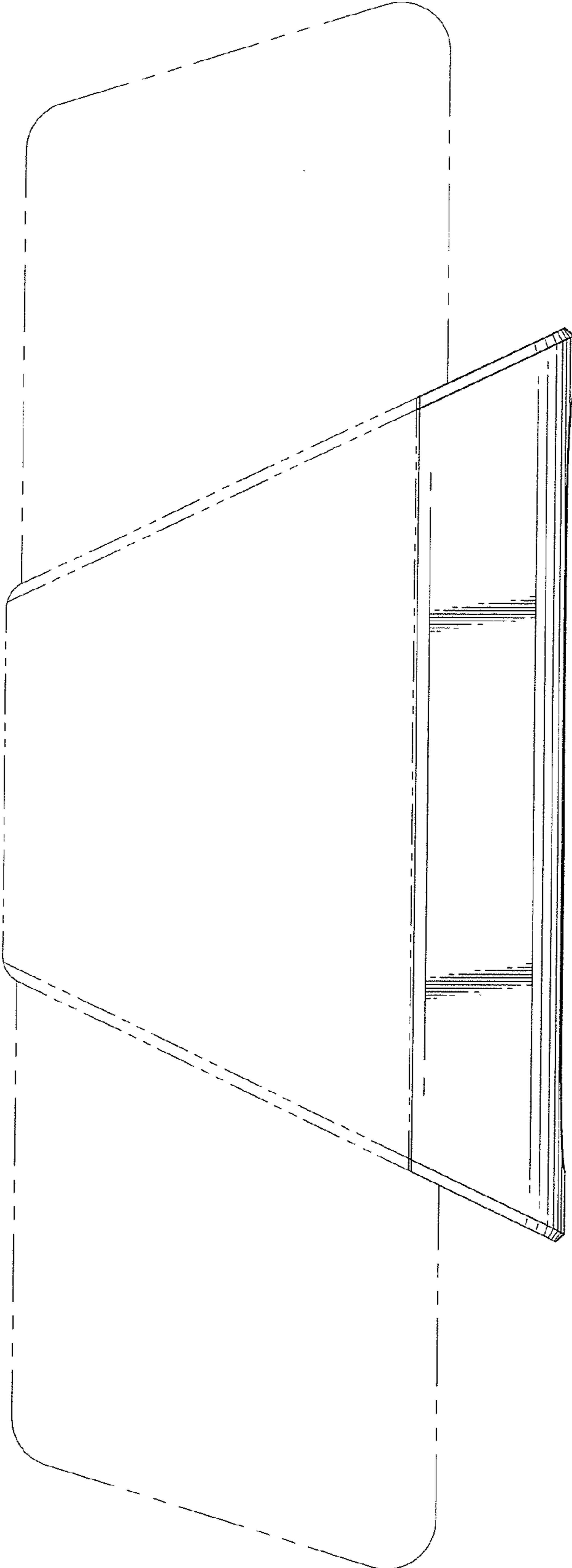

FIG. 12

