



US00D678953S

(12) **United States Design Patent**
Bengyak

(10) **Patent No.:** **US D678,953 S**
(45) **Date of Patent:** **** Mar. 26, 2013**

(54) **HAND SIGN**

(76) Inventor: **Christopher Edward Bengyak**, Vero Beach, FL (US)

(**) Term: **14 Years**

(21) Appl. No.: **29/421,494**

(22) Filed: **Jul. 31, 2012**

(51) **LOC (9) Cl.** **20-03**

(52) **U.S. Cl.** **D20/33; D20/35**

(58) **Field of Classification Search** D20/10,
D20/19, 29-33, 35, 36, 99; 40/446, 538,
40/541, 584, 586; D2/615; D10/109.1, 109.2;
D11/131, 157, 158; D21/400

See application file for complete search history.

(56) **References Cited**

U.S. PATENT DOCUMENTS

D86,456 S *	3/1932	Herzog	D20/35
D102,121 S *	12/1936	Baker	D20/35
D164,567 S *	9/1951	Gosselin	D20/32
D269,191 S *	5/1983	Segal	D20/35
D360,653 S *	7/1995	McKee	D20/33
D429,285 S *	8/2000	Schini	D20/32
D633,945 S *	3/2011	Scott	D20/33
D633,946 S *	3/2011	Scott	D20/33
D641,791 S *	7/2011	Scott	D20/33
D664,598 S *	7/2012	Bengyak	D20/30

OTHER PUBLICATIONS

Detroit Red Wings—Trademark Registration No. 0891121, May 12, 1970 Detroit Red Wings, Inc. Corporation Assignee of Michigan Trademark Electronic Service System (TESS).*

* cited by examiner

Primary Examiner — Mary Ann Calabrese

(57) **CLAIM**

The ornamental design for a hand sign, as shown and described.

DESCRIPTION

FIG. 1 is a right-side elevational view of a first embodiment of a left-hand hand sign according to the invention;

FIG. 2 is a left-side elevational view of the left-hand hand sign of FIG. 1;

FIG. 3 is a reduced scale rear elevational view of the left-hand hand sign of FIG. 1;

FIG. 4 is a reduced scale front elevational view of the left-hand hand sign of FIG. 1;

FIG. 5 is a reduced scale top plan view of the left-hand hand sign of FIG. 1;

FIG. 6 is a reduced scale bottom plan view of the left-hand hand sign of FIG. 1;

FIG. 7 is a perspective view from below the front of the right side of the left-hand hand sign of FIG. 1;

FIG. 8 is a left-side elevational view of a second embodiment of a right-hand hand sign according to the invention;

FIG. 9 is a right-side elevational view of the right-hand hand sign of FIG. 8;

FIG. 10 is a reduced scale front elevational view of the right-hand hand sign of FIG. 8;

FIG. 11 is a reduced scale rear elevational view of the right-hand hand sign of FIG. 8;

FIG. 12 is a reduced scale top plan view of the right-hand hand sign of FIG. 8;

FIG. 13 is a reduced scale bottom plan view of the right-hand hand sign of FIG. 8; and,

FIG. 14 is a perspective view from below the front of the left side of the right-hand hand sign of FIG. 8.

The Stylized Tire with Wing is a registered trademark owned by Detroit Red Wings, Inc. Corporation Assignee of Michigan 600 Civic Center Detroit Michigan 48226.

1 Claim, 10 Drawing Sheets

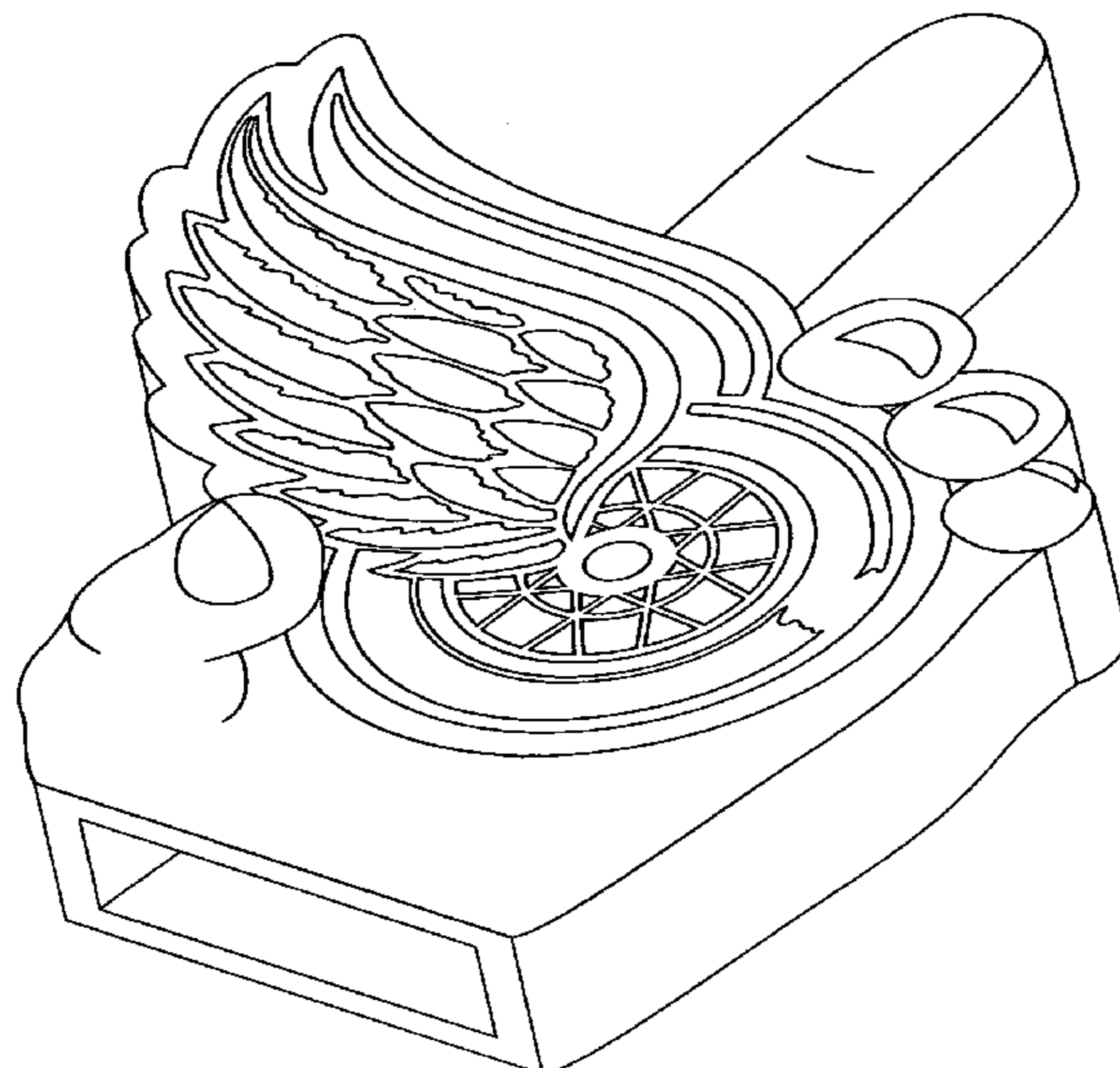

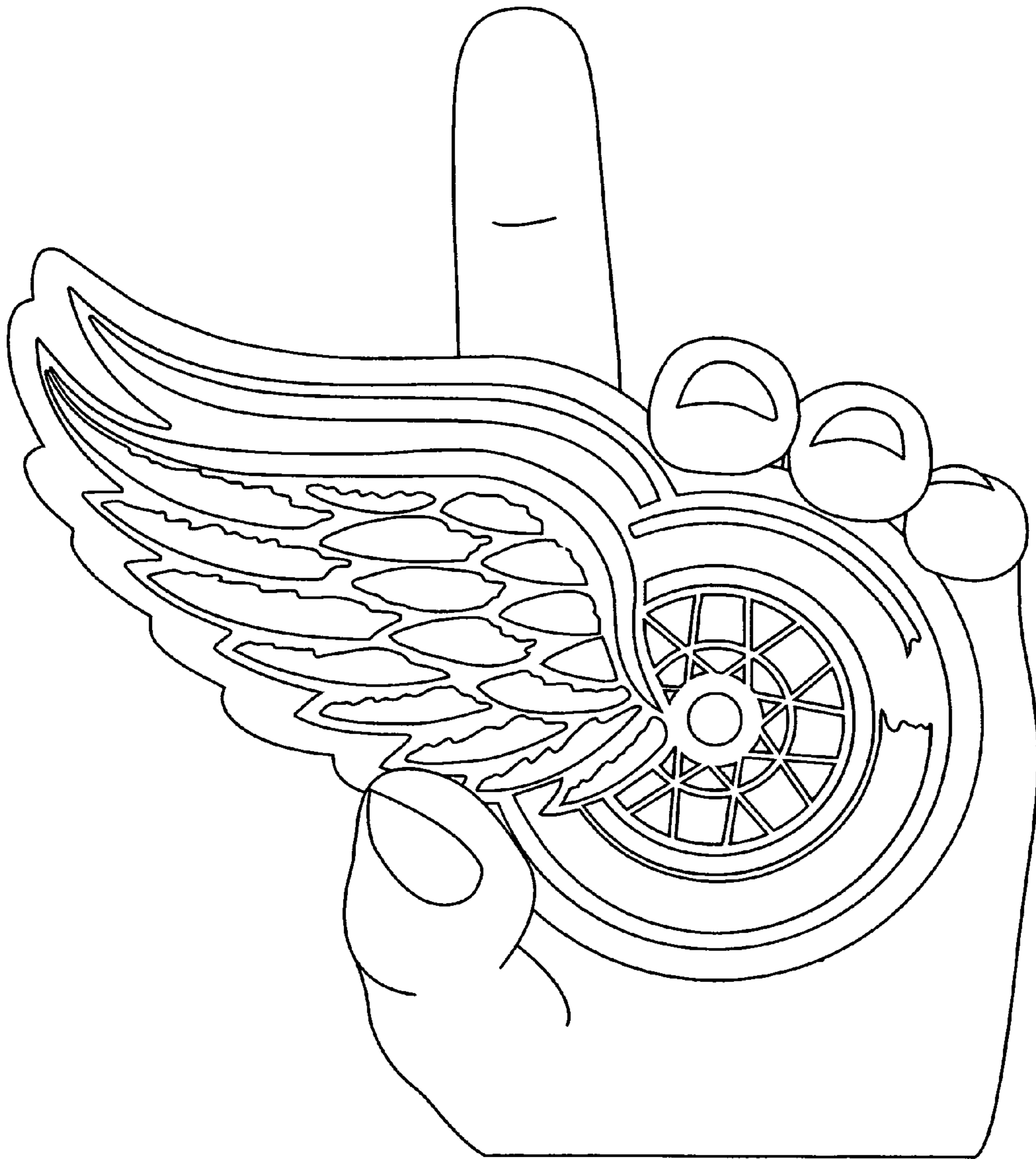

FIG. 1

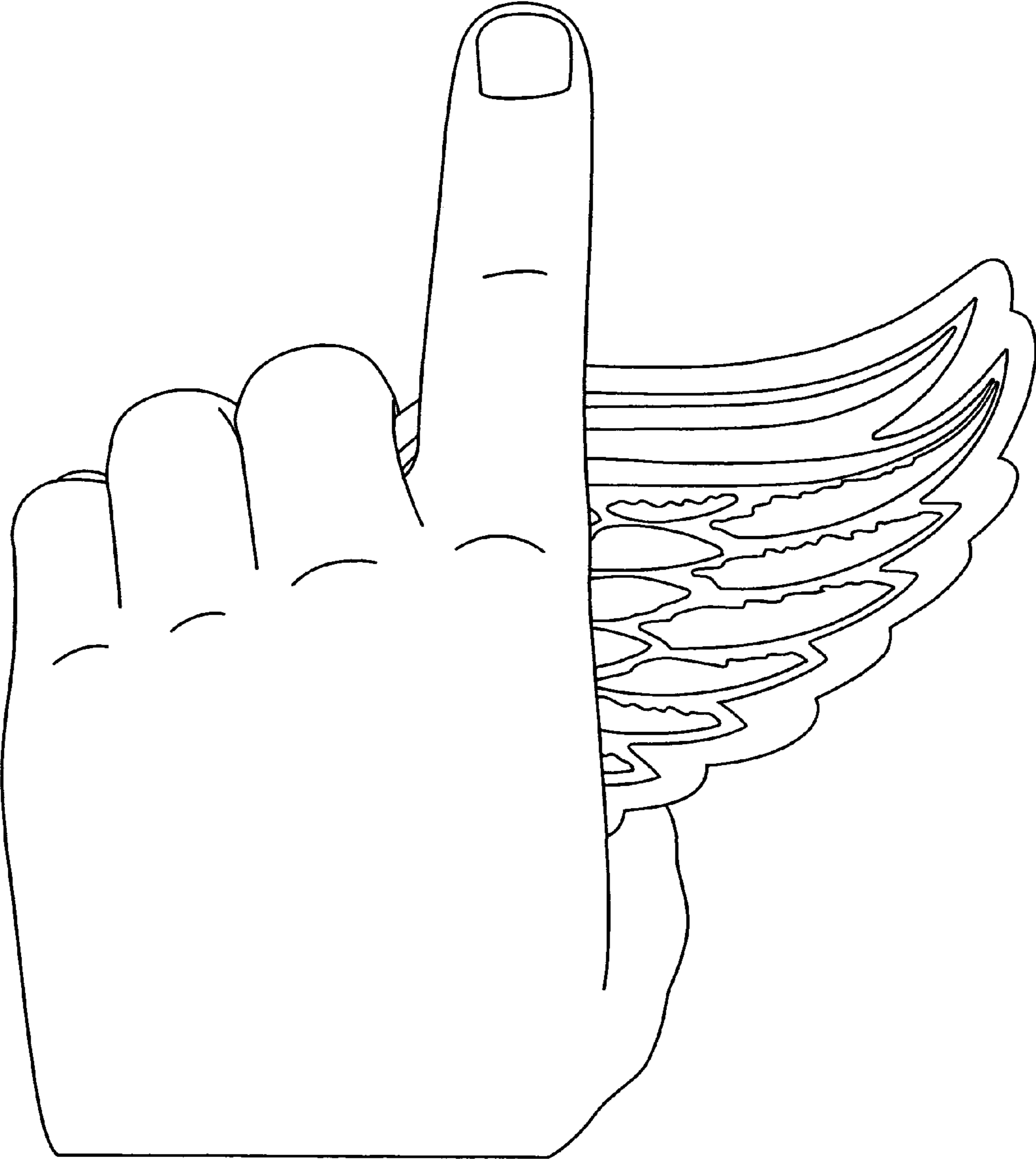

FIG. 2

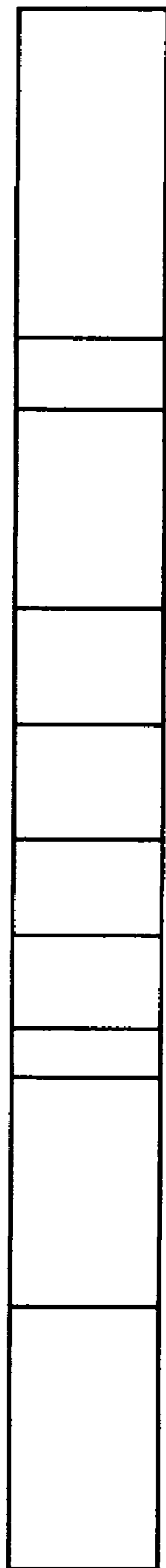

FIG. 3

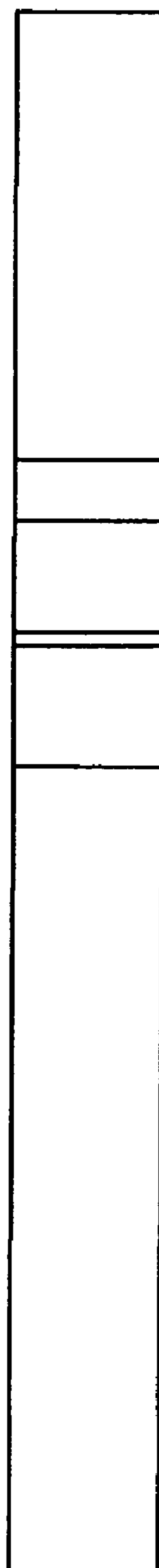

FIG. 4



FIG. 5

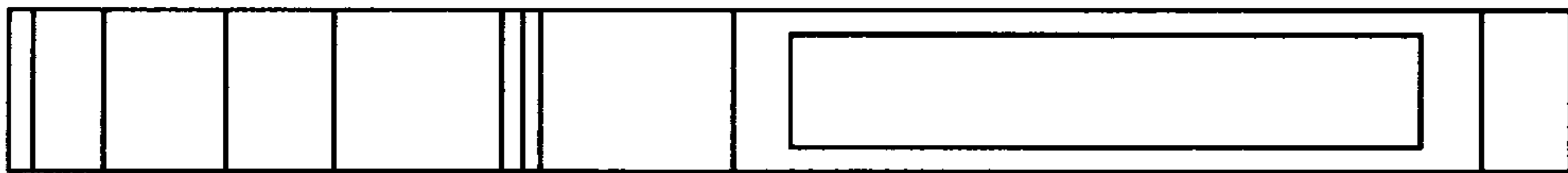

FIG. 6

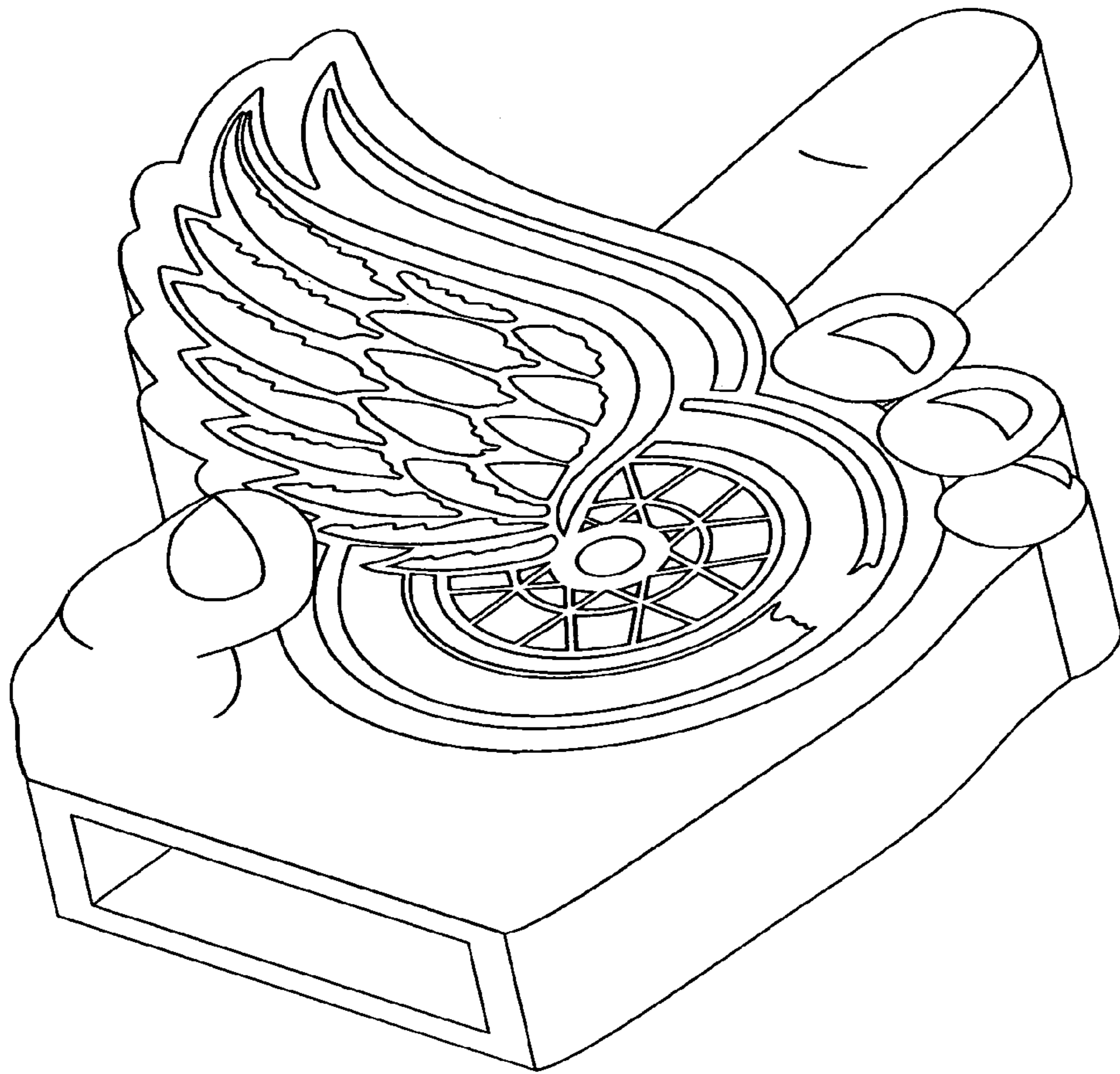

FIG. 7

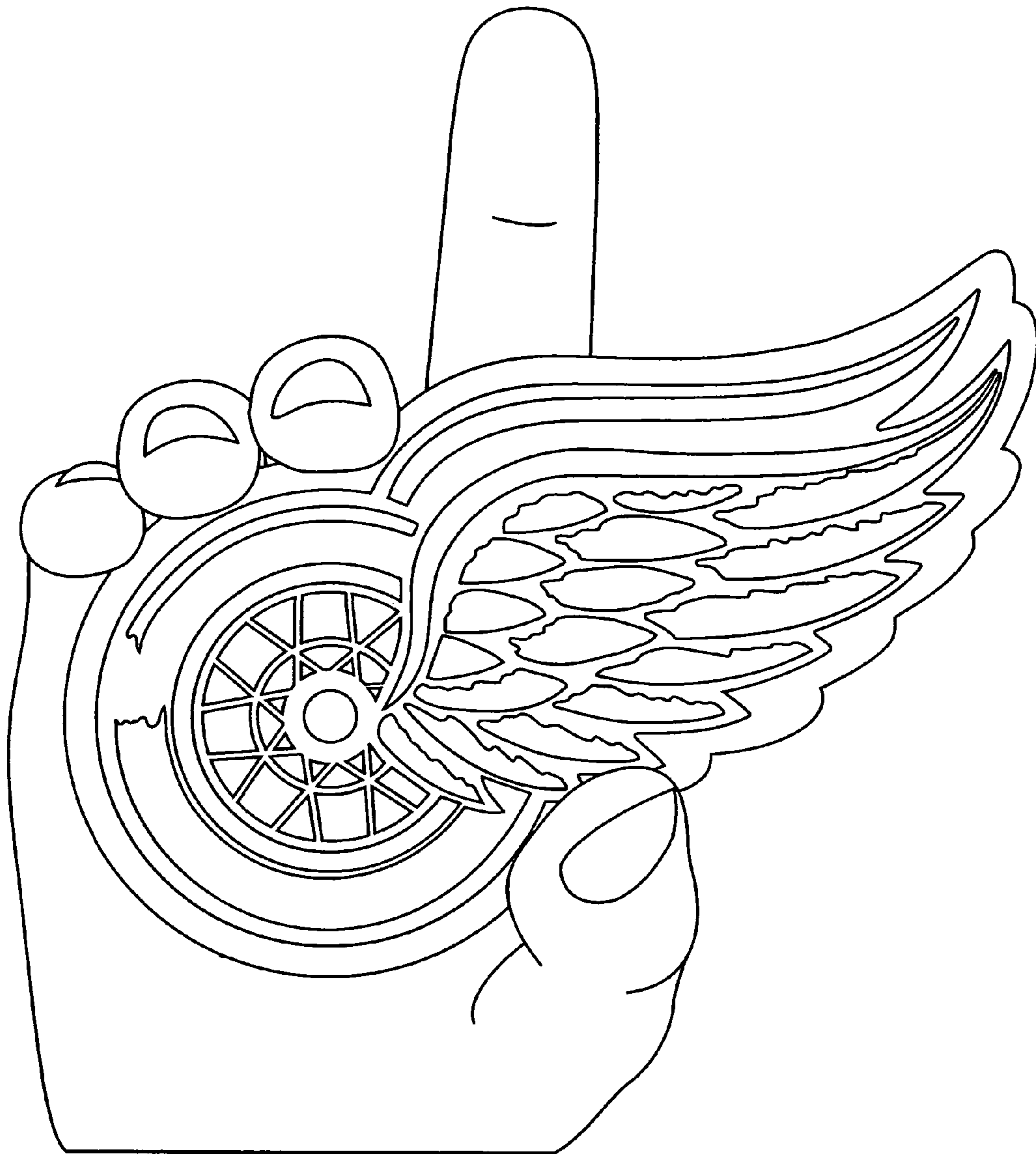

FIG. 8

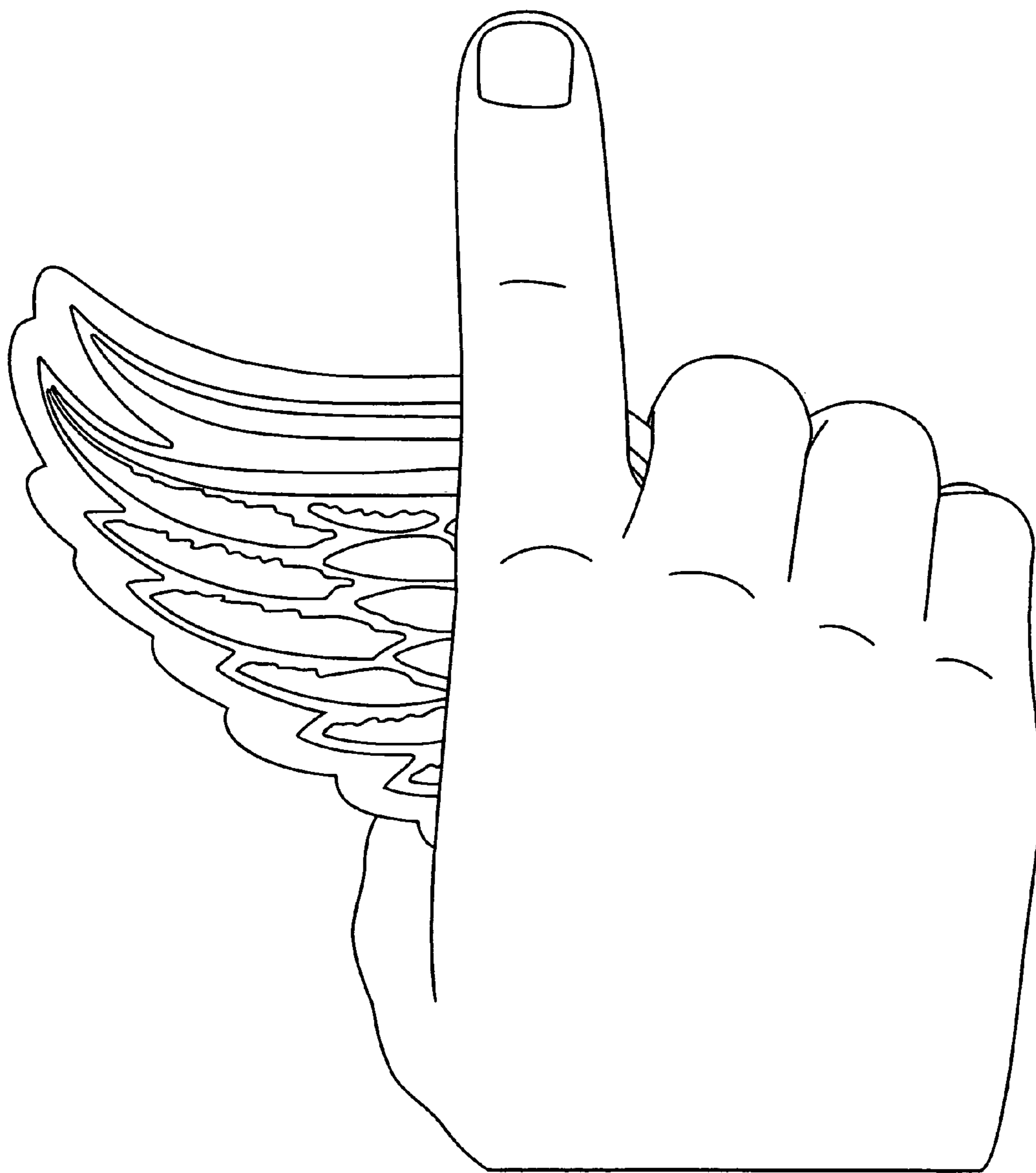

FIG. 9

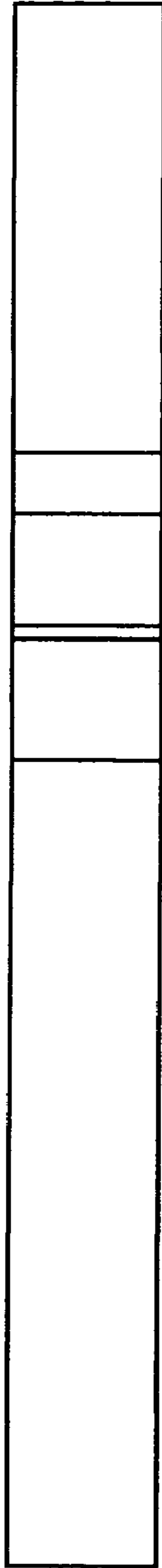

FIG. 10

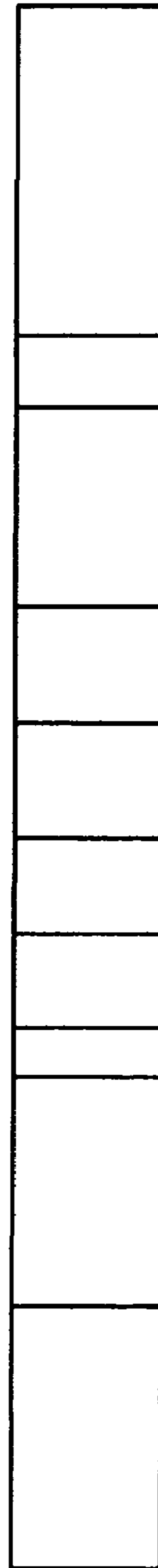

FIG. 11



FIG. 12

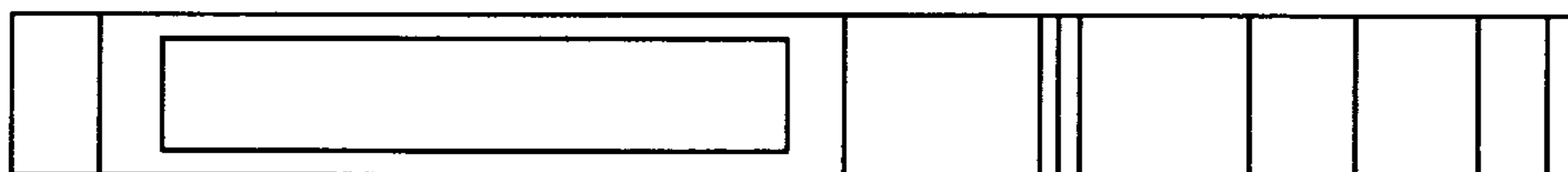

FIG. 13

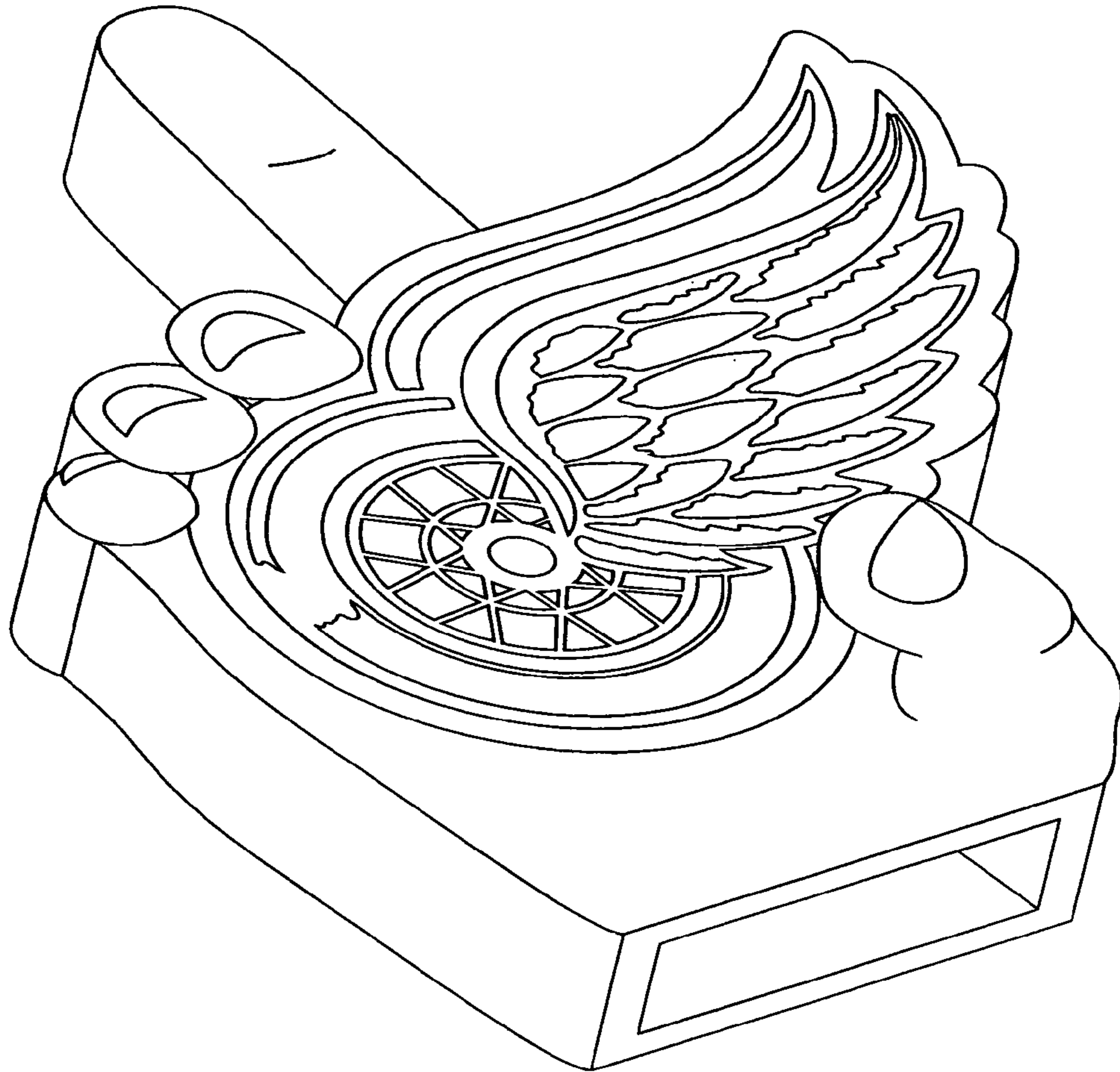

FIG. 14