



US00D678531S

(12) **United States Design Patent**
Patil

(10) **Patent No.:** **US D678,531 S**

(45) **Date of Patent:** **** Mar. 19, 2013**

(54) **TELEMETRY TRANSMITTER**

(75) Inventor: **Mahendra Madhukar Patil**, Bangalore
(IN)

(73) Assignee: **General Electric Company**,
Schenectady, NY (US)

(**) Term: **14 Years**

(21) Appl. No.: **29/400,935**

(22) Filed: **Sep. 2, 2011**

(51) **LOC (9) Cl.** **24-01**

(52) **U.S. Cl.** **D24/186**

(58) **Field of Classification Search** D24/107,
D24/155, 158, 164, 165, 167, 169, 170, 185–187,
D24/216, 231; 600/300, 301, 368, 372, 490,
600/493–495, 499–501, 529, 544, 554, 561;
D10/31, 81; D14/336; 434/236, 262; 128/900,
128/903–904

See application file for complete search history.

(56) **References Cited**

U.S. PATENT DOCUMENTS

D268,783 S *	4/1983	Henshaw	D24/167
D278,746 S *	5/1985	Saynajakangas	D24/168
D326,521 S *	5/1992	Sawada	D24/167
D341,423 S *	11/1993	Bible	D24/186
D414,870 S *	10/1999	Saltzstein et al.	D24/186
D446,306 S *	8/2001	Ochi et al.	D24/165
D452,012 S *	12/2001	Phillips	D24/186
D470,590 S *	2/2003	Maeda et al.	D24/167
D490,516 S *	5/2004	Takahashi et al.	D24/107
D492,783 S *	7/2004	Lax	D24/167
D492,999 S *	7/2004	Lax	D24/167
D519,636 S *	4/2006	Okuda et al.	D24/168
D536,793 S *	2/2007	Assad et al.	D24/185
D554,266 S *	10/2007	Striepe et al.	D24/186
D609,351 S *	2/2010	Wagener et al.	D24/186
D616,549 S *	5/2010	Sudhir	D24/167
D621,048 S *	8/2010	Severe et al.	D24/167

D627,476 S *	11/2010	Gaw et al.	D24/186
D634,431 S *	3/2011	Severe et al.	D24/167
D652,522 S *	1/2012	Koester	D24/186

* cited by examiner

Primary Examiner — T. Chase Nelson

Assistant Examiner — Mark Cavanna

(74) *Attorney, Agent, or Firm* — The Small Patent Law
Group; Dean D. Small

(57) **CLAIM**

The ornamental design of a telemetry transmitter, as shown
and described.

DESCRIPTION

FIG. 1 is a front perspective view of a telemetry transmitter
showing my new design.

FIG. 2 is a rear perspective view of the telemetry transmitter
shown in FIG. 1.

FIG. 3 is another front perspective view of the telemetry
transmitter shown in FIG. 1.

FIG. 4 is another rear perspective view of the telemetry trans-
mitter shown in FIG. 1.

FIG. 5 is a front elevation view of the telemetry transmitter
shown in FIG. 1.

FIG. 6 is a rear elevation view of the telemetry transmitter
shown in FIG. 1.

FIG. 7 is a side elevation view of the telemetry transmitter
shown in FIG. 1.

FIG. 8 is another side elevation view of the telemetry trans-
mitter shown in FIG. 1.

FIG. 9 is a top plan view of the telemetry transmitter shown in
FIG. 1; and,

FIG. 10 is a bottom plan view of the telemetry transmitter
shown in FIG. 1.

The broken lines are included for the purpose of illustrating
portions of the telemetry system that form no part of the
claimed design.

1 Claim, 5 Drawing Sheets

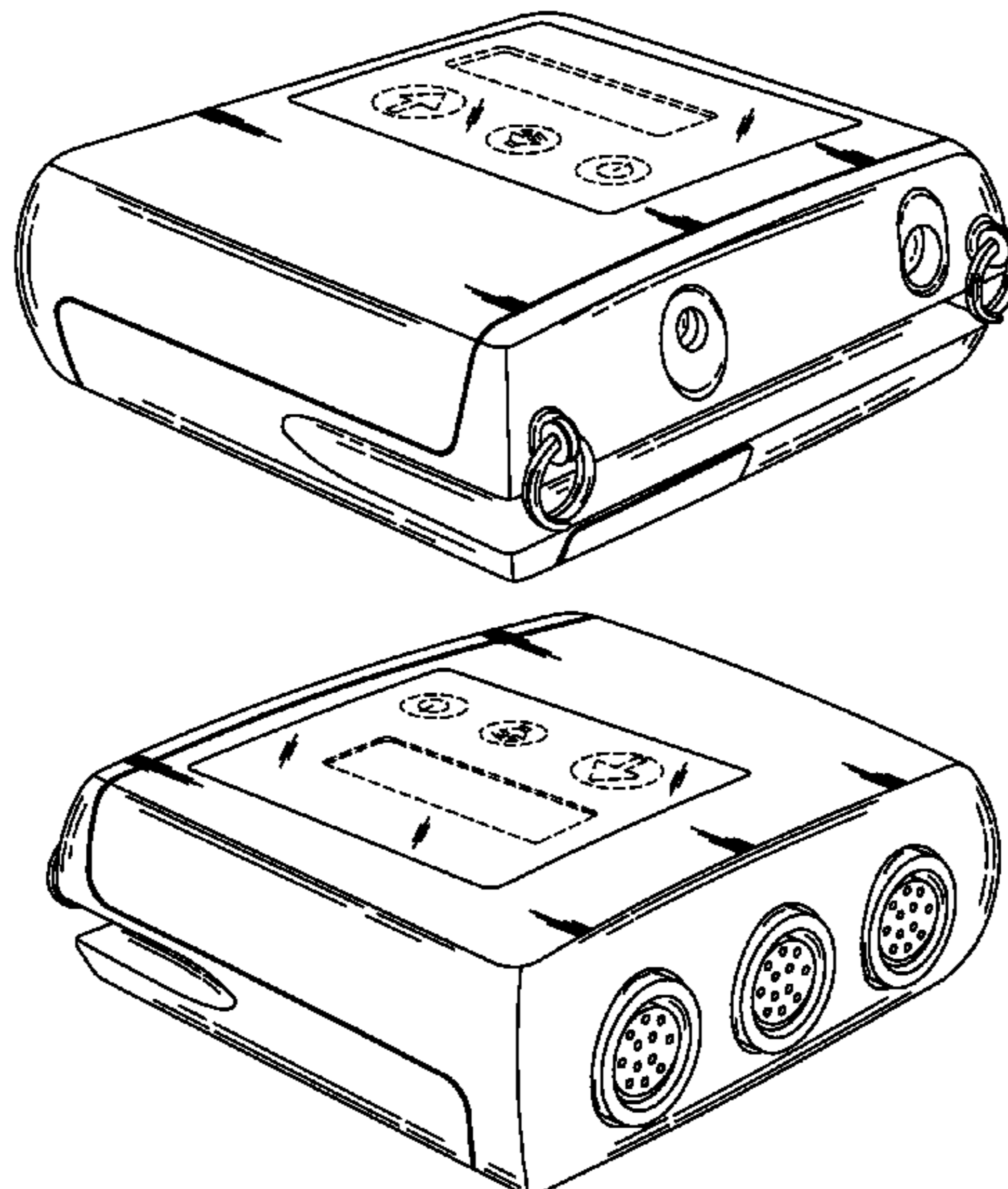

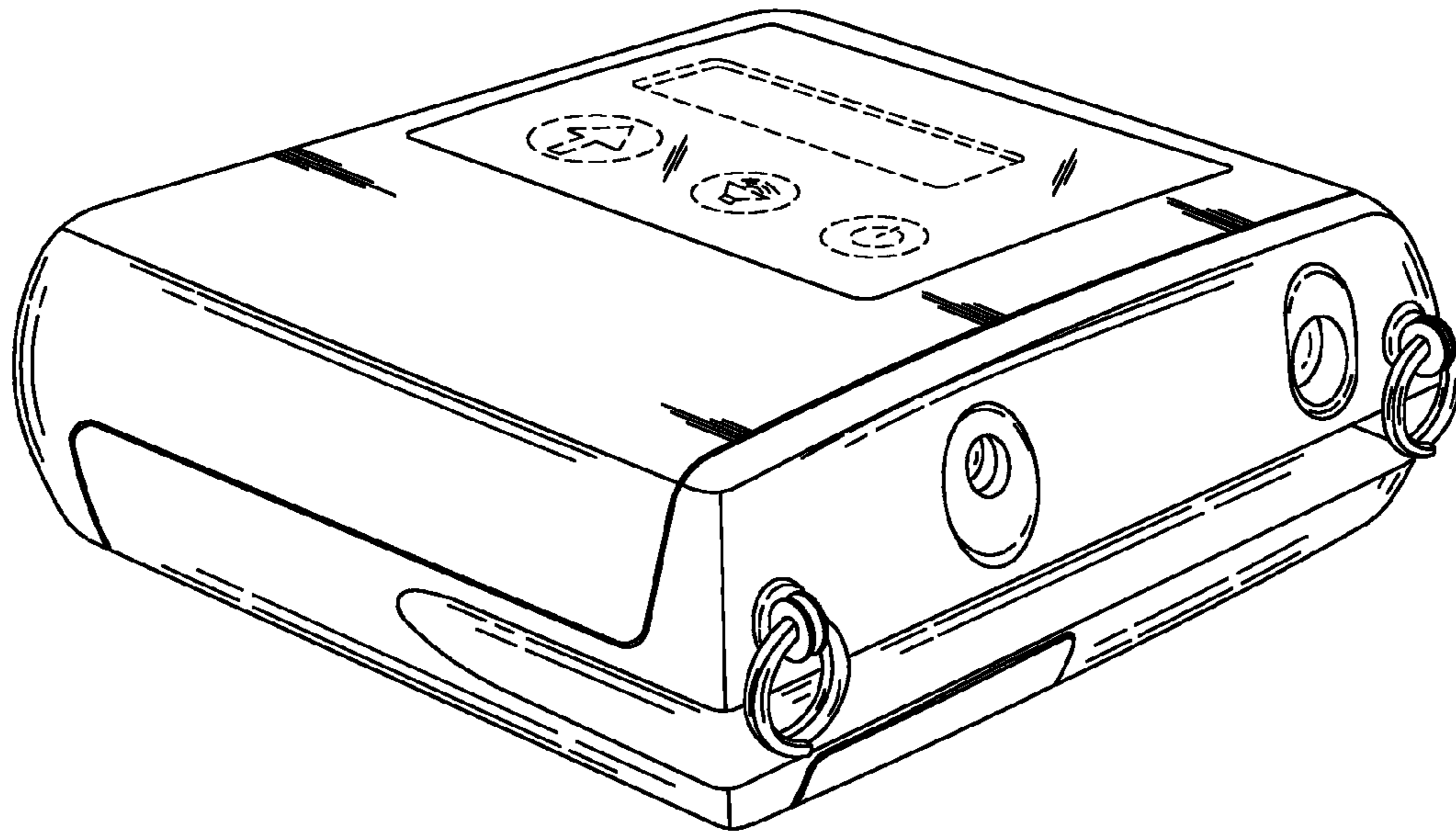

FIG. 1

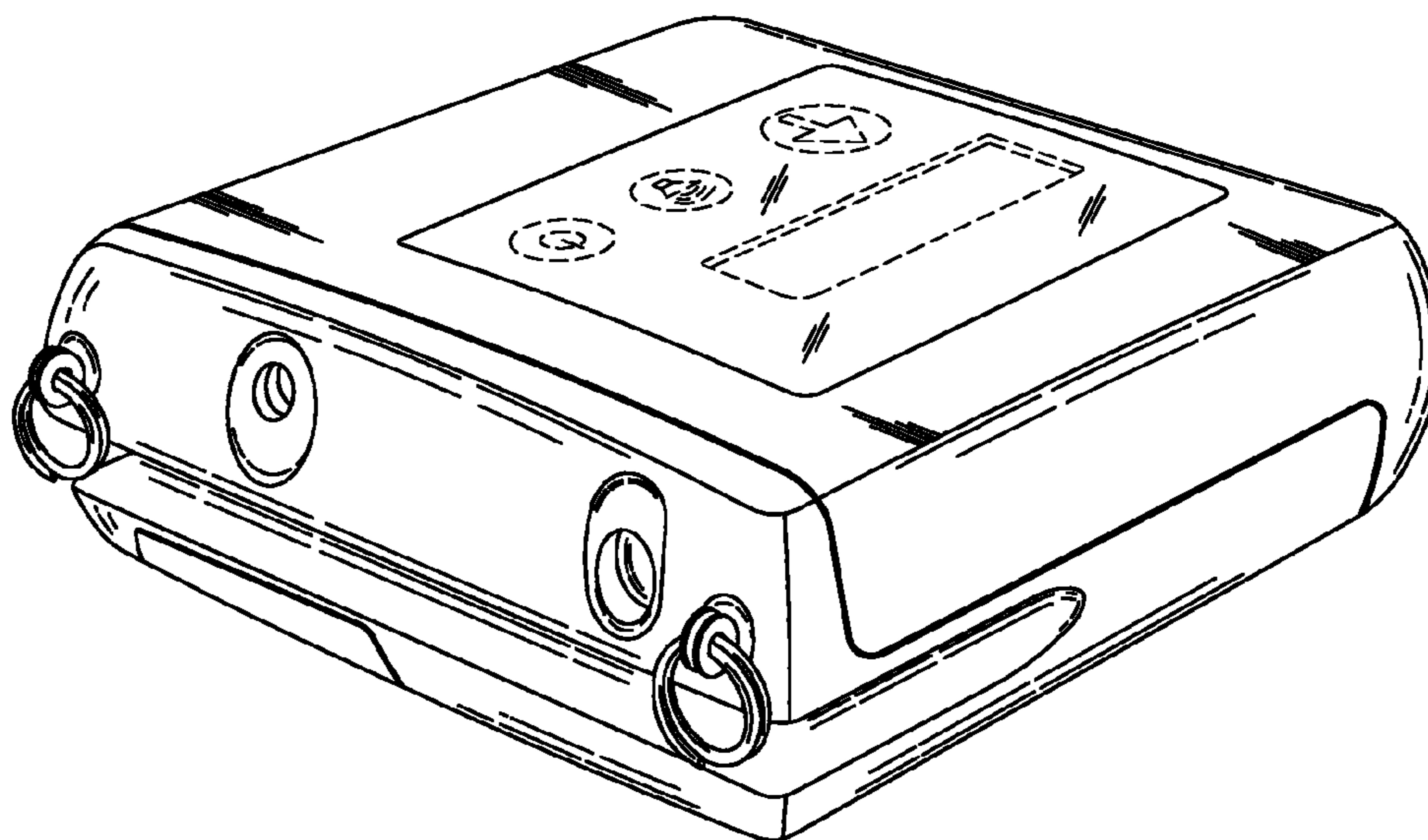

FIG. 2

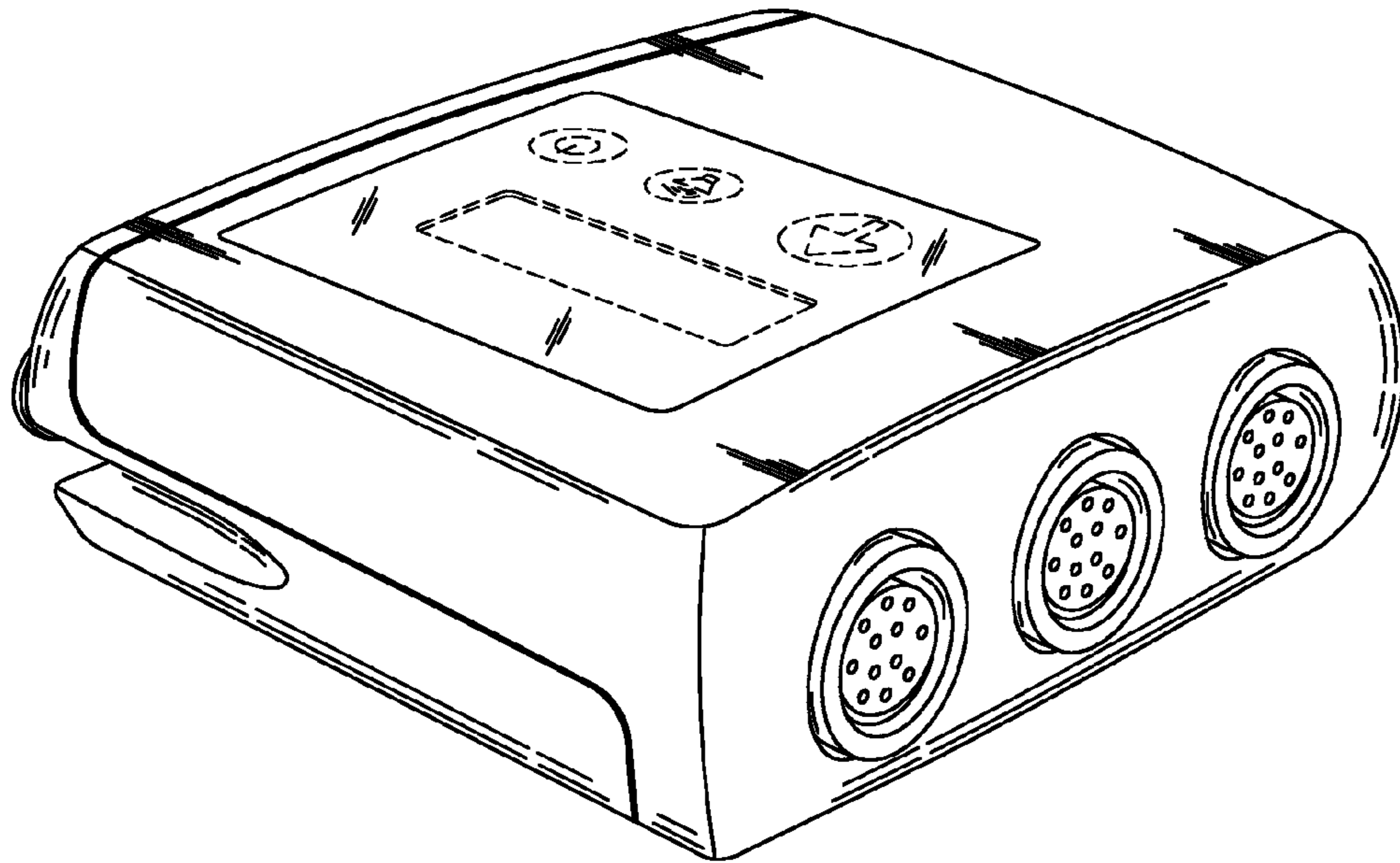

FIG. 3

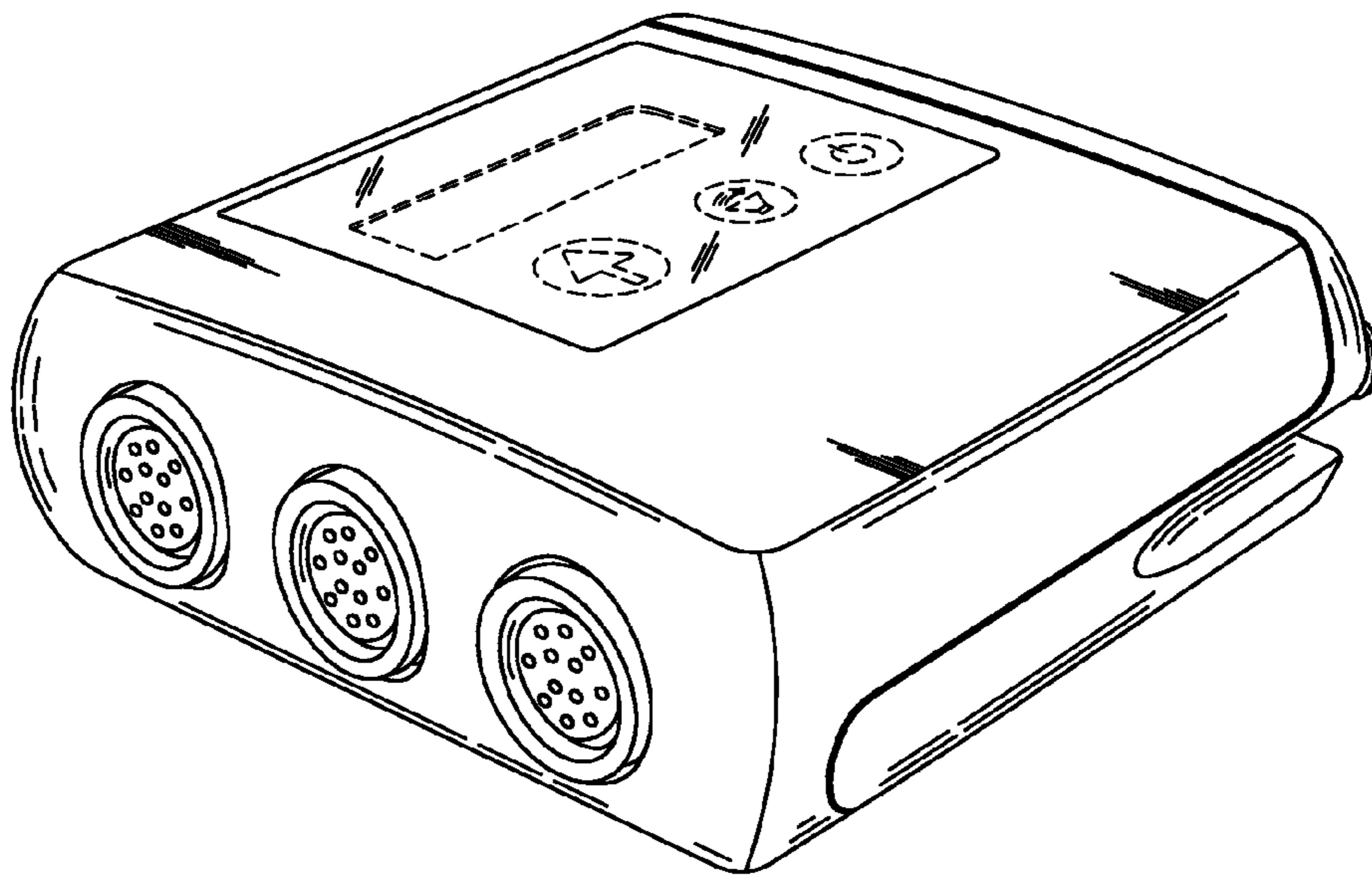

FIG. 4

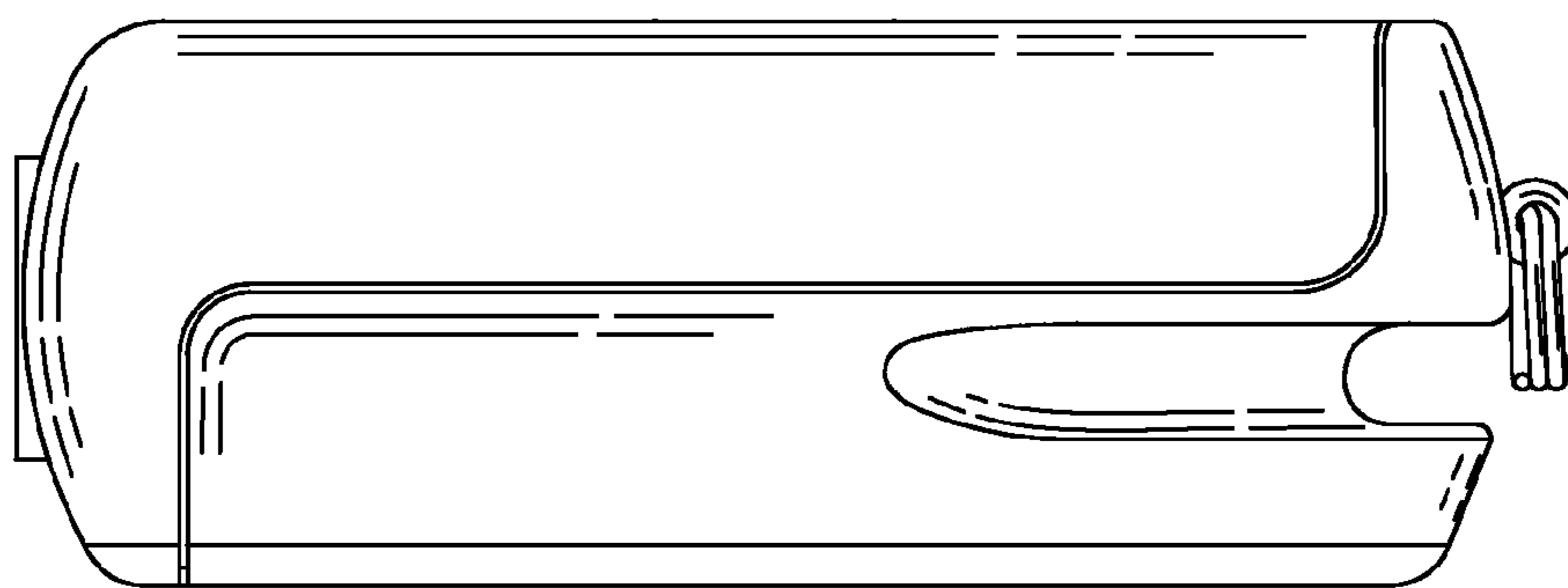

FIG. 5

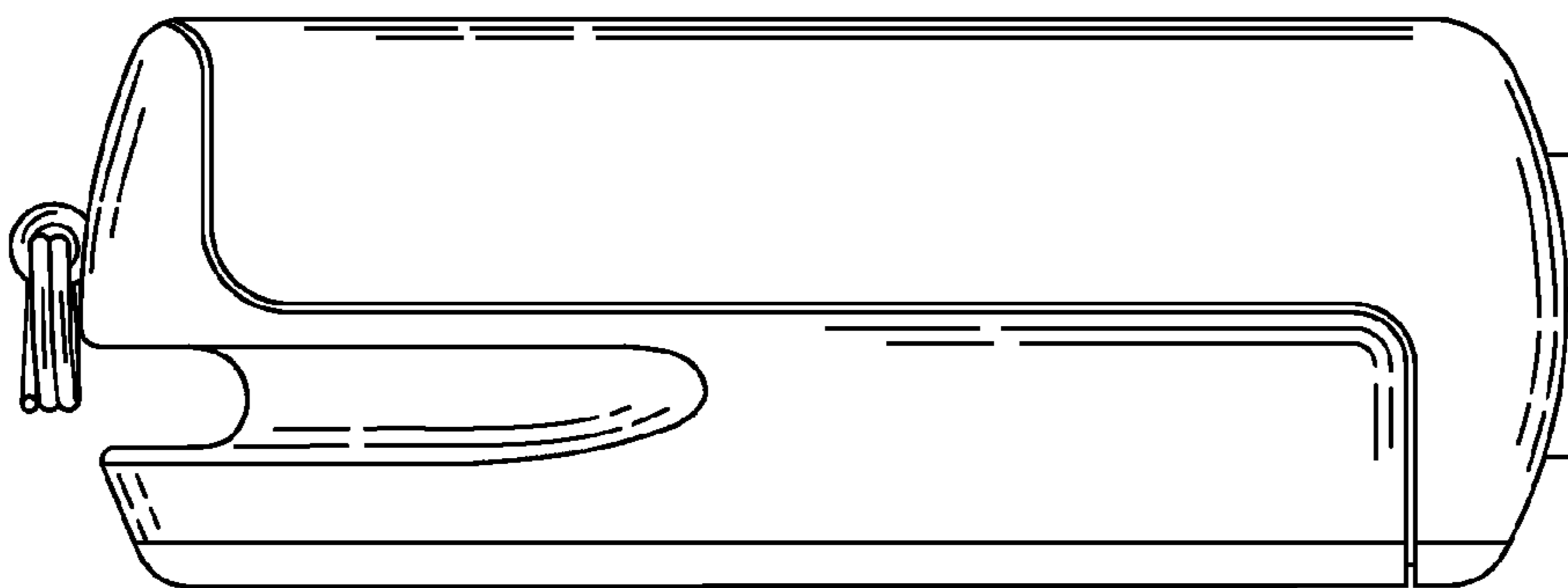

FIG. 6

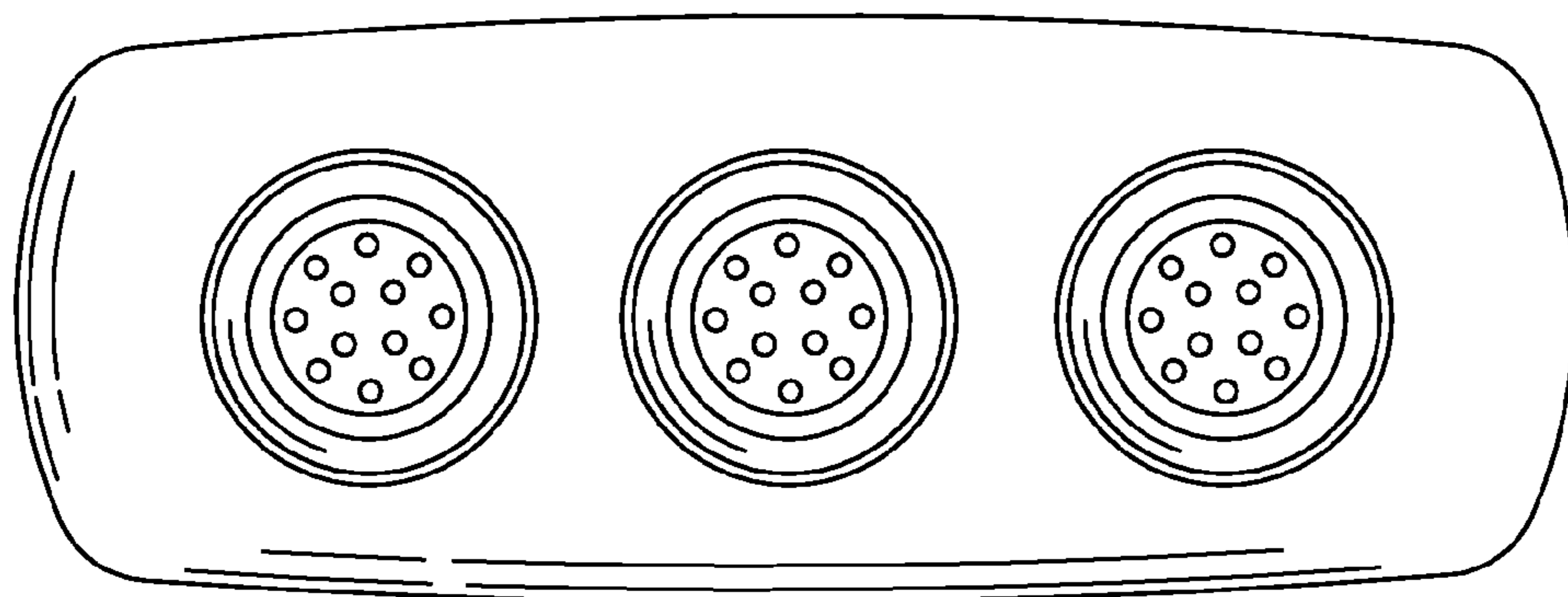

FIG. 7

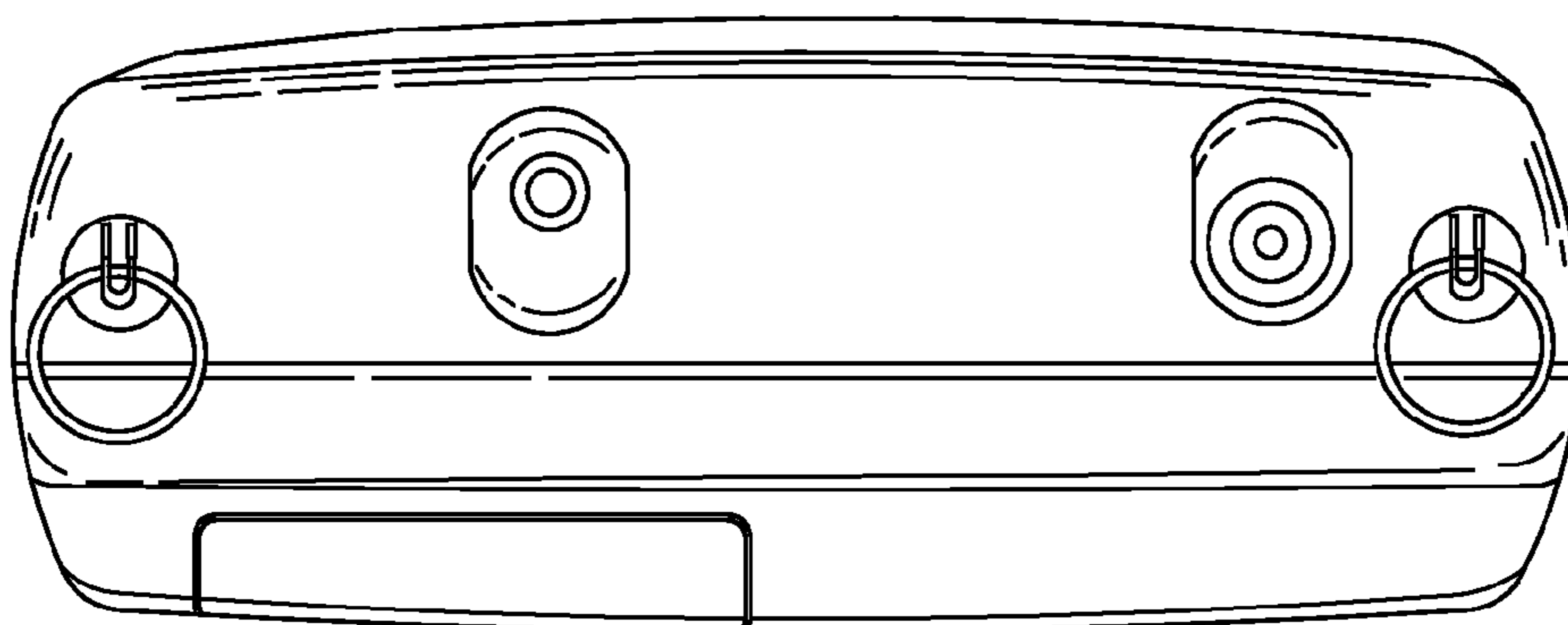

FIG. 8

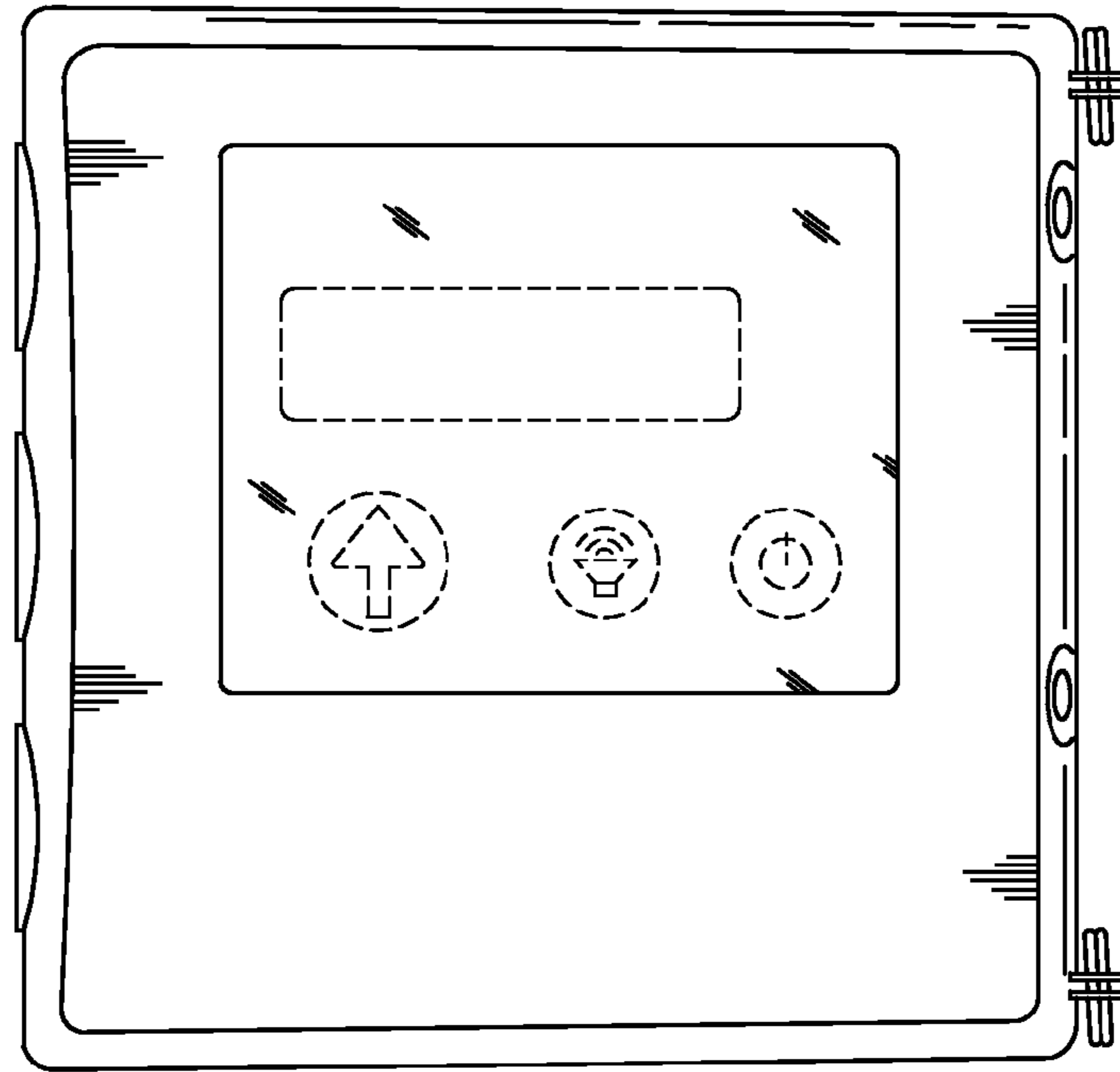

FIG. 9

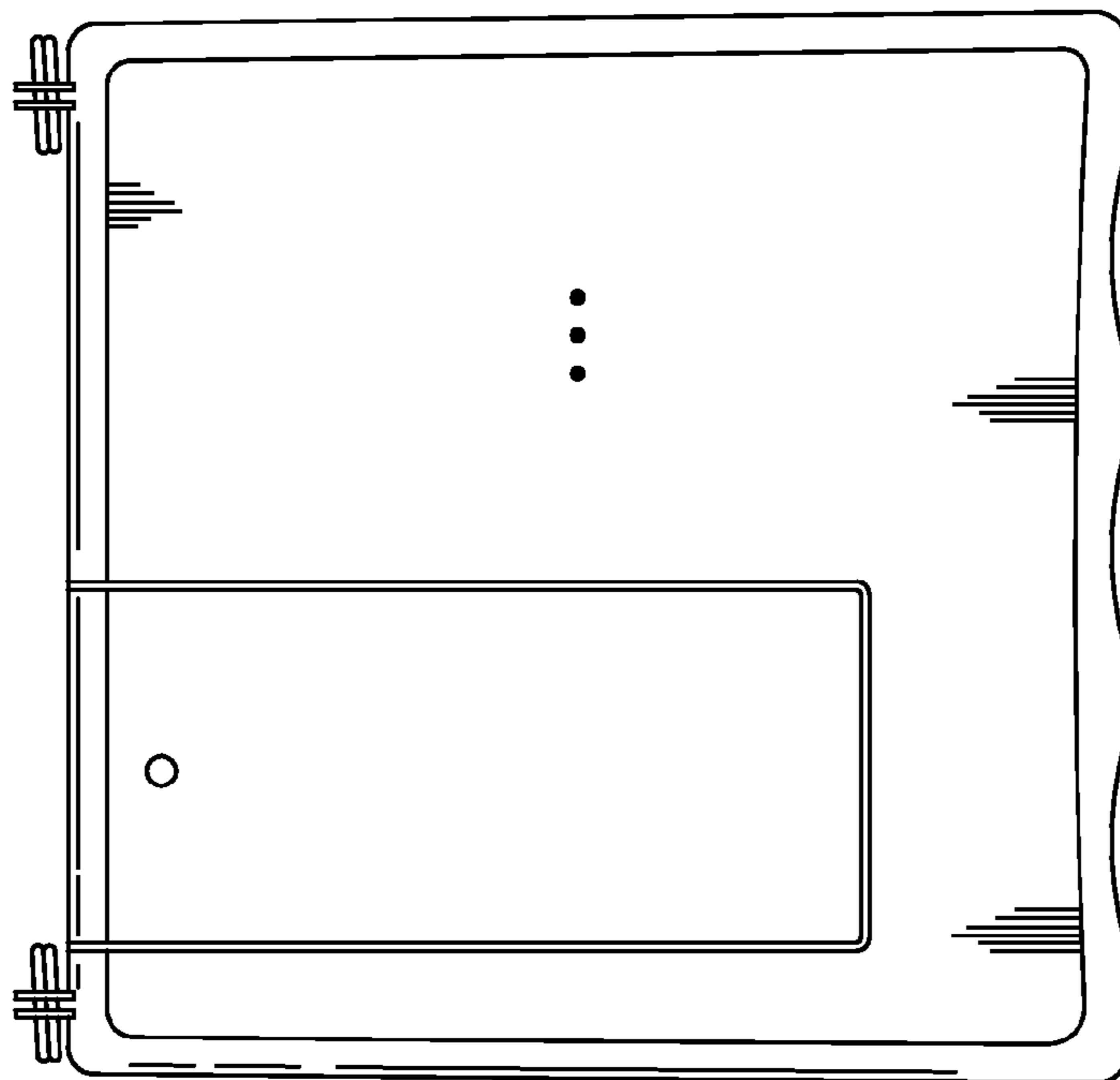

FIG. 10