



US00D678377S

(12) **United States Design Patent**
Umeno

(10) **Patent No.:** **US D678,377 S**
(45) **Date of Patent:** **** Mar. 19, 2013**

(54) **INDUSTRIAL ROBOT HAND**

(75) Inventor: **Makoto Umeno**, Fukuoka (JP)

(73) Assignee: **Kabushiki Kaisha Yaskawa Denki**,
Kitakyushu-Shi (JP)

(**) Term: **14 Years**

(21) Appl. No.: **29/409,706**

(22) Filed: **Dec. 28, 2011**

(30) **Foreign Application Priority Data**

Jun. 28, 2011 (JP) 2011-014631

(51) **LOC (9) Cl.** **15-99**

(52) **U.S. Cl.** **D15/199**

(58) **Field of Classification Search** D15/199;
D21/578, 593, 594, 621; 74/490.01, 490.02,
74/490.03, 490.05; 219/124.34, 639; 222/129,
222/129.3; 318/560, 568.12, 568.2; 446/268-274,
446/279, 280, 289-292, 298, 300, 353, 354,
446/376, 378-384; 700/99, 150, 264, 281
See application file for complete search history.

(56) **References Cited**

U.S. PATENT DOCUMENTS

4,540,212	A *	9/1985	Inaba et al.	294/202
4,815,781	A *	3/1989	No et al.	294/198
7,016,144	B2 *	3/2006	Yamakawa et al.	360/92.1
D651,625	S *	1/2012	Koike et al.	D15/199
D663,757	S *	7/2012	Thoman et al.	D15/199
2004/0012878	A1 *	1/2004	Yamakawa et al.	360/92
2006/0158146	A1 *	7/2006	Tadano	318/568.21
2006/0196707	A1 *	9/2006	Wang et al.	177/245
2006/0232086	A1 *	10/2006	Hariki et al.	294/106
2008/0073922	A1 *	3/2008	Holtz	294/88

2009/0067973	A1 *	3/2009	Eliuk et al.	414/729
2009/0114054	A1 *	5/2009	Horiuchi et al.	74/490.05
2010/0095799	A1 *	4/2010	Albin et al.	74/490.01
2010/0101356	A1 *	4/2010	Albin	74/490.03
2011/0115244	A1 *	5/2011	Kamon et al.	294/106
2011/0241369	A1 *	10/2011	Kamon et al.	294/213
2012/0049555	A1 *	3/2012	Fujii et al.	294/213
2012/0205931	A1 *	8/2012	Ohta	294/213

* cited by examiner

Primary Examiner — Patricia Palasik

(74) *Attorney, Agent, or Firm* — Ditthavong Mori & Steiner,
P.C.

(57) **CLAIM**

The ornamental design for an industrial robot hand, as shown and described.

DESCRIPTION

FIG. 1 is a rear and right side perspective view of an industrial robot hand, showing my new design;
FIG. 2 is a front and left side perspective view thereof;
FIG. 3 is a front view thereof;
FIG. 4 is a rear side view thereof;
FIG. 5 is a top plan view thereof;
FIG. 6 is a bottom view thereof;
FIG. 7 is a left side view thereof;
FIG. 8 is a right side view thereof;
FIG. 9 is a rear and right side perspective view showing the industrial robot hand in which claws thereof are closed;
FIG. 10 is an exemplary front view showing the industrial robot hand attached to one industrial robot arm; and,
FIG. 11 is an exemplary front view showing the industrial robot hand attached to the other industrial robot arm.
The broken lines in the drawings depict unclaimed environmental subject matter.

1 Claim, 11 Drawing Sheets

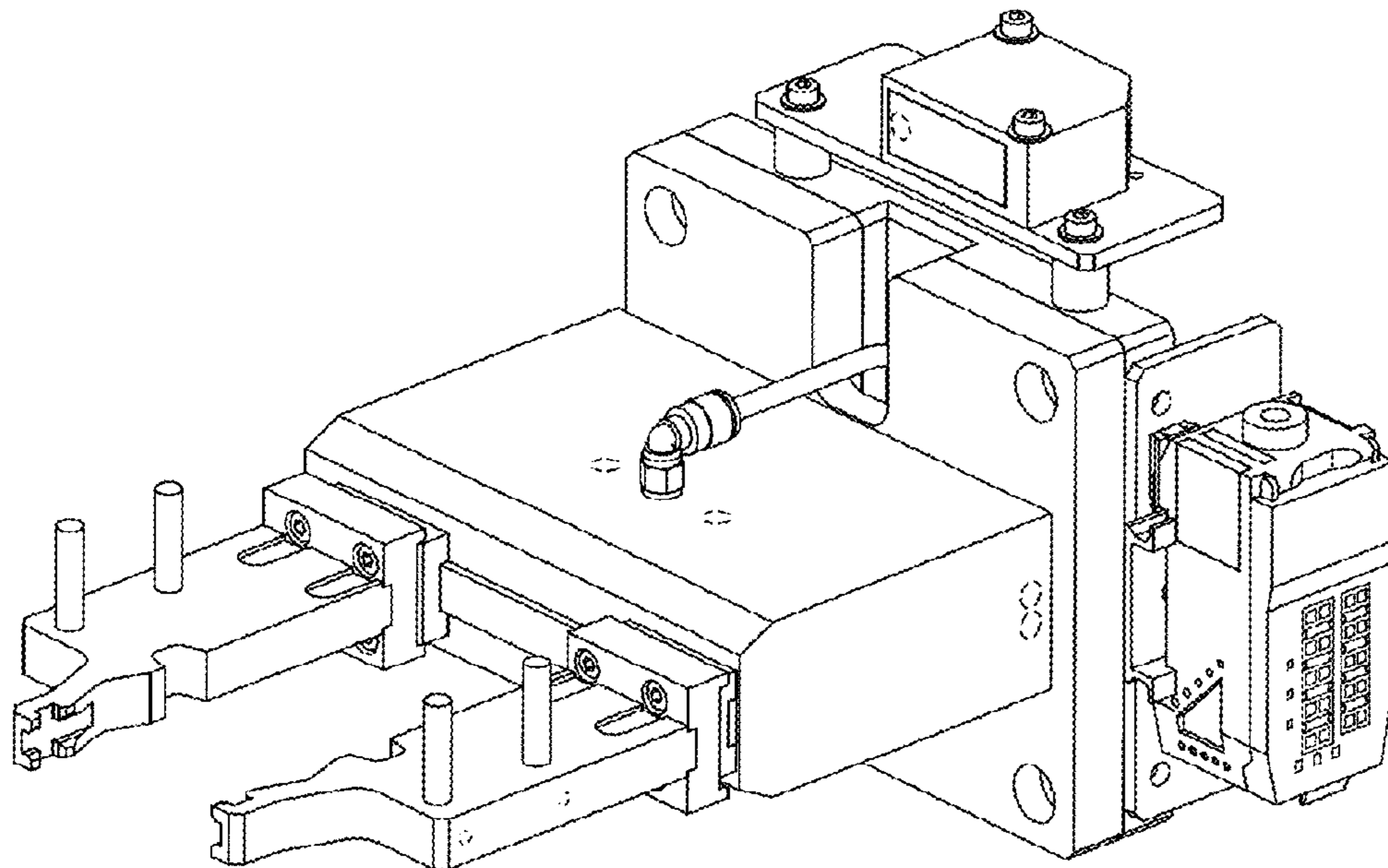

FIG. 1

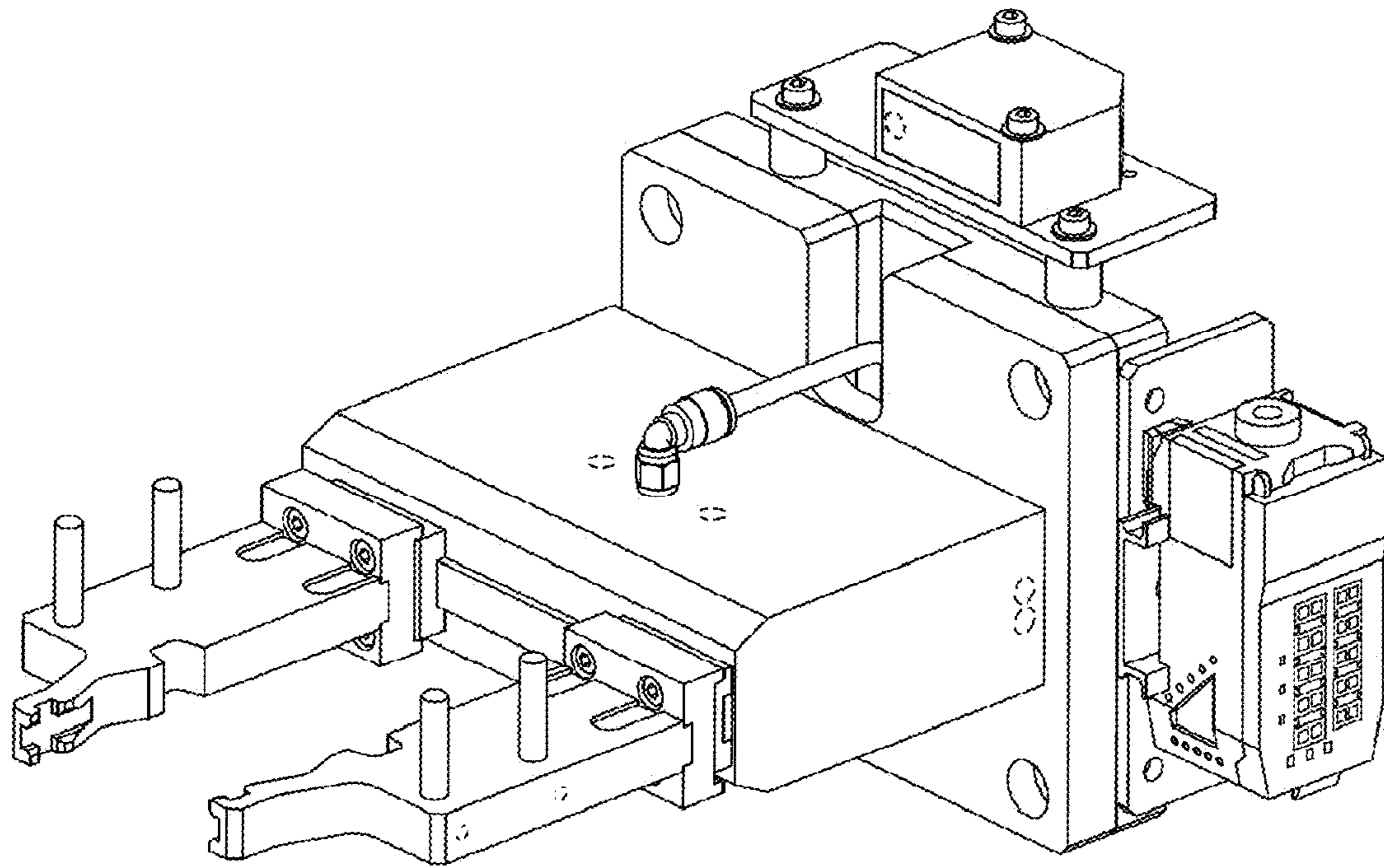

FIG. 2

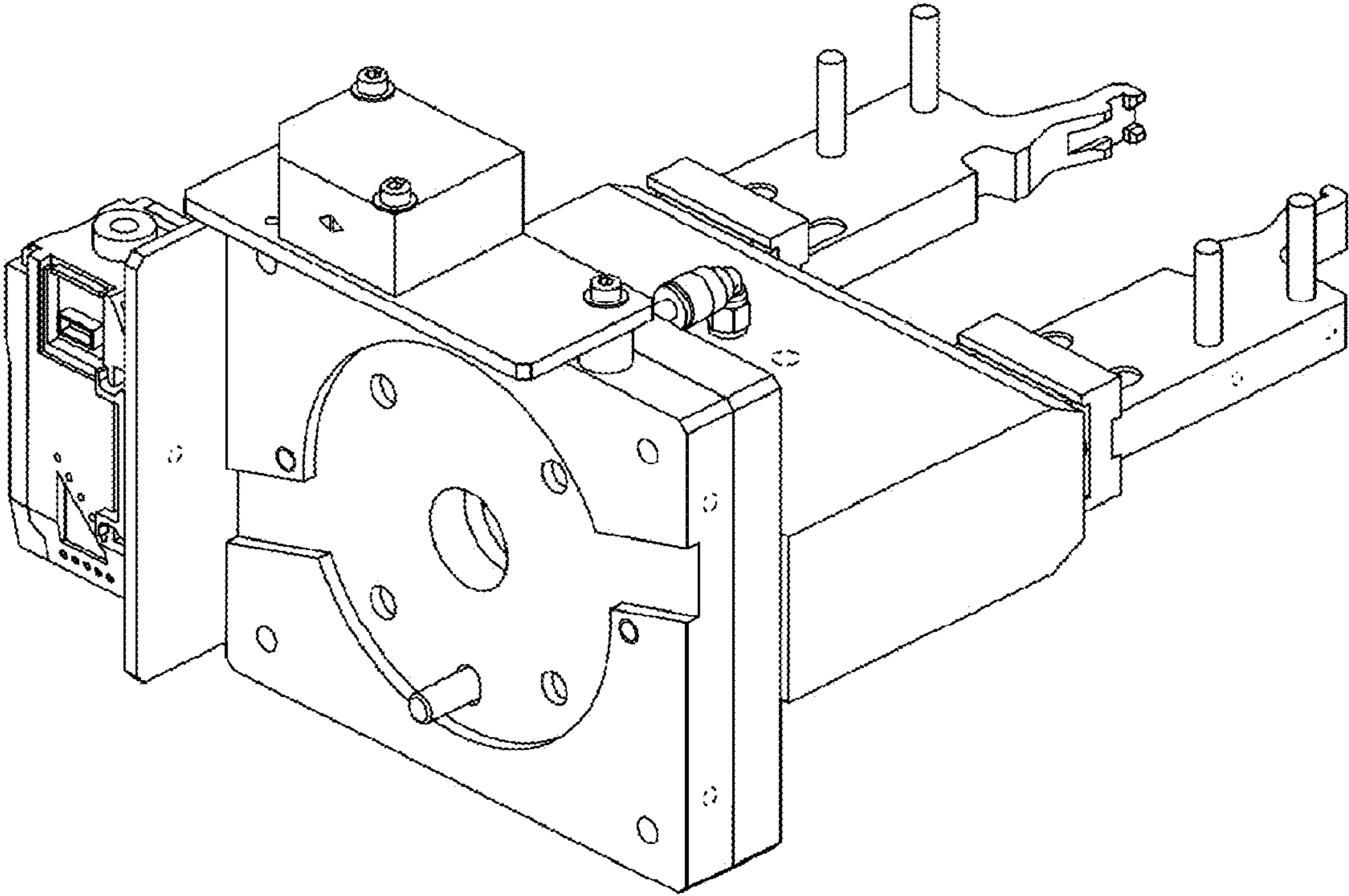

FIG. 3

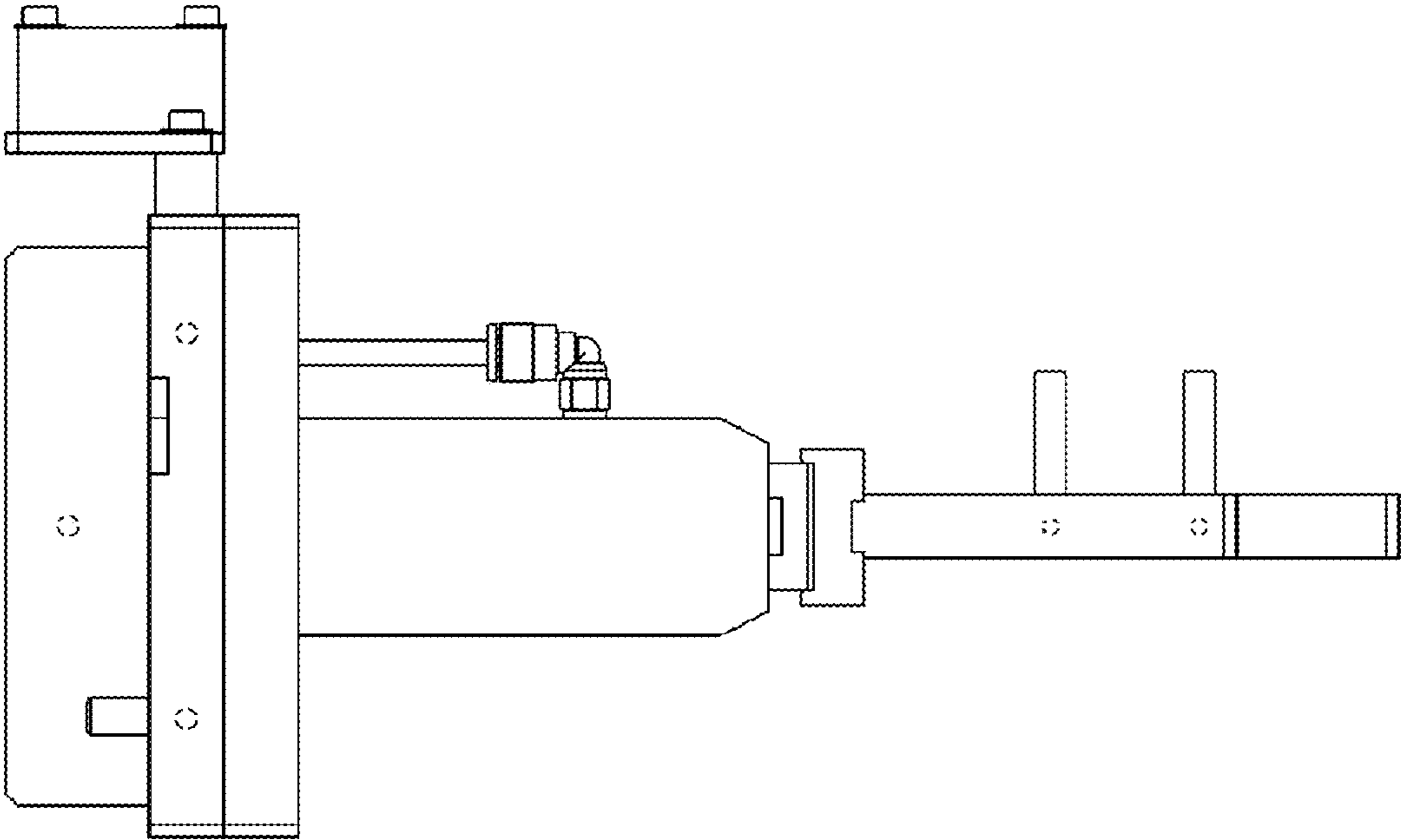

FIG. 4

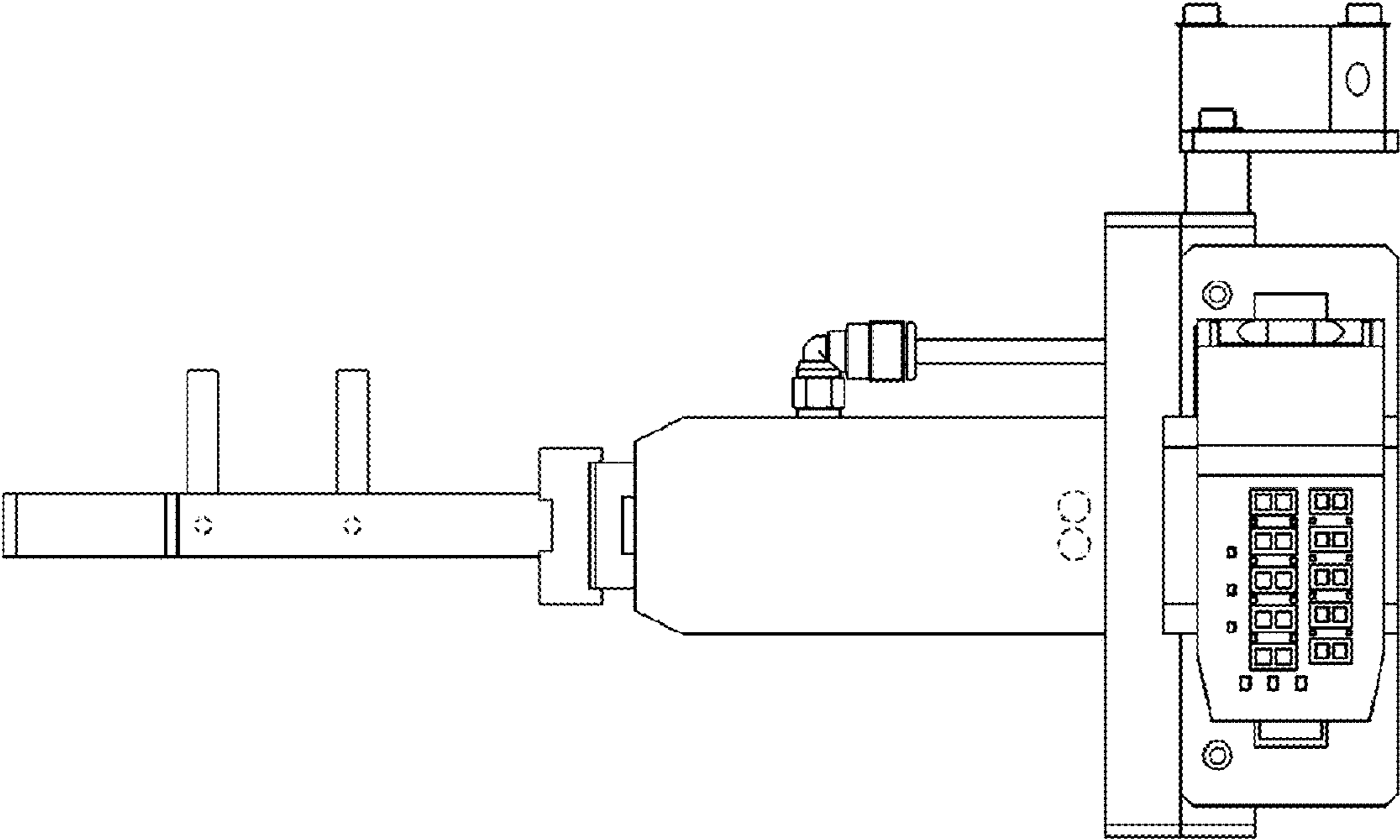

FIG. 5

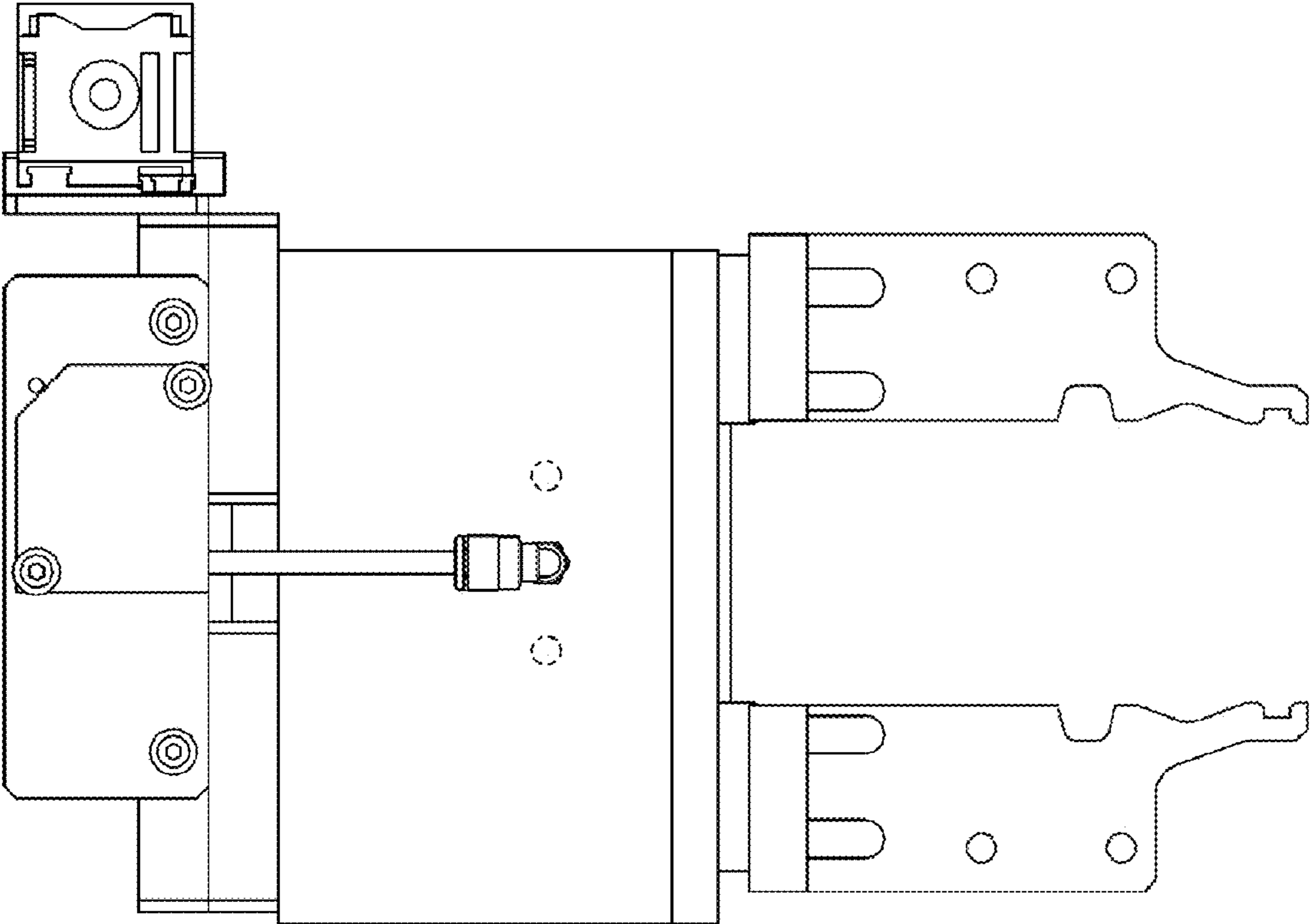

FIG. 6

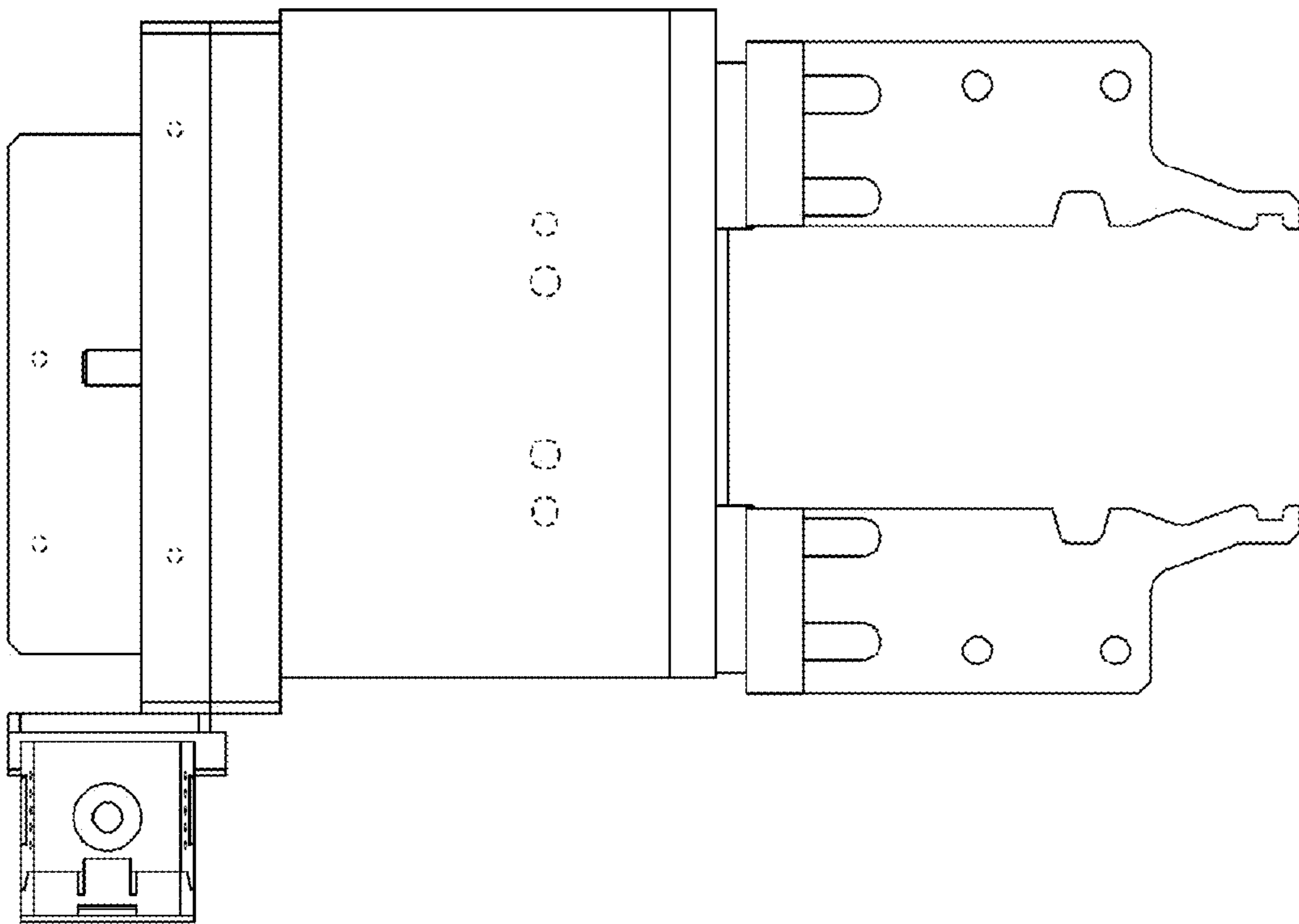

FIG. 7

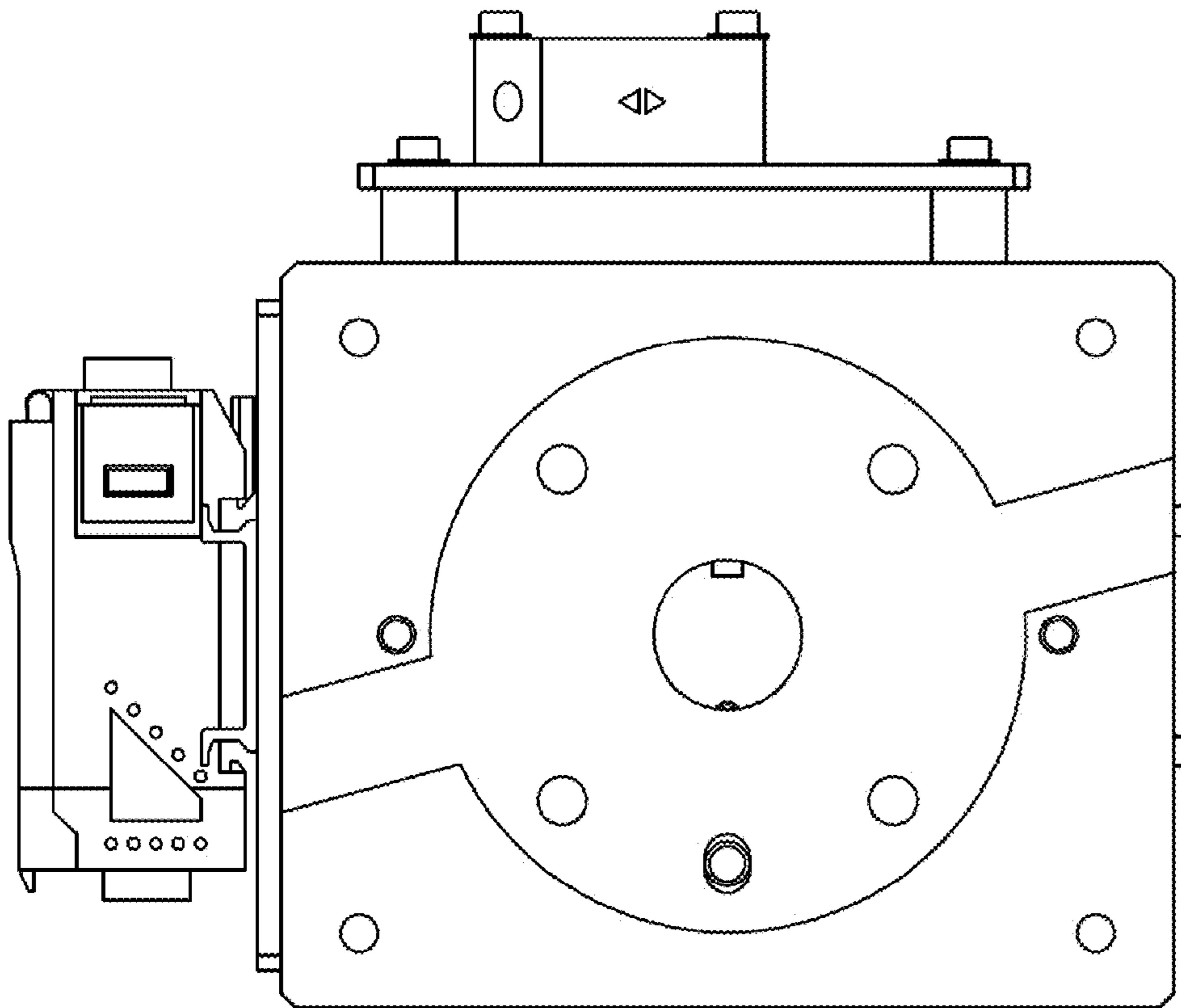

FIG. 8

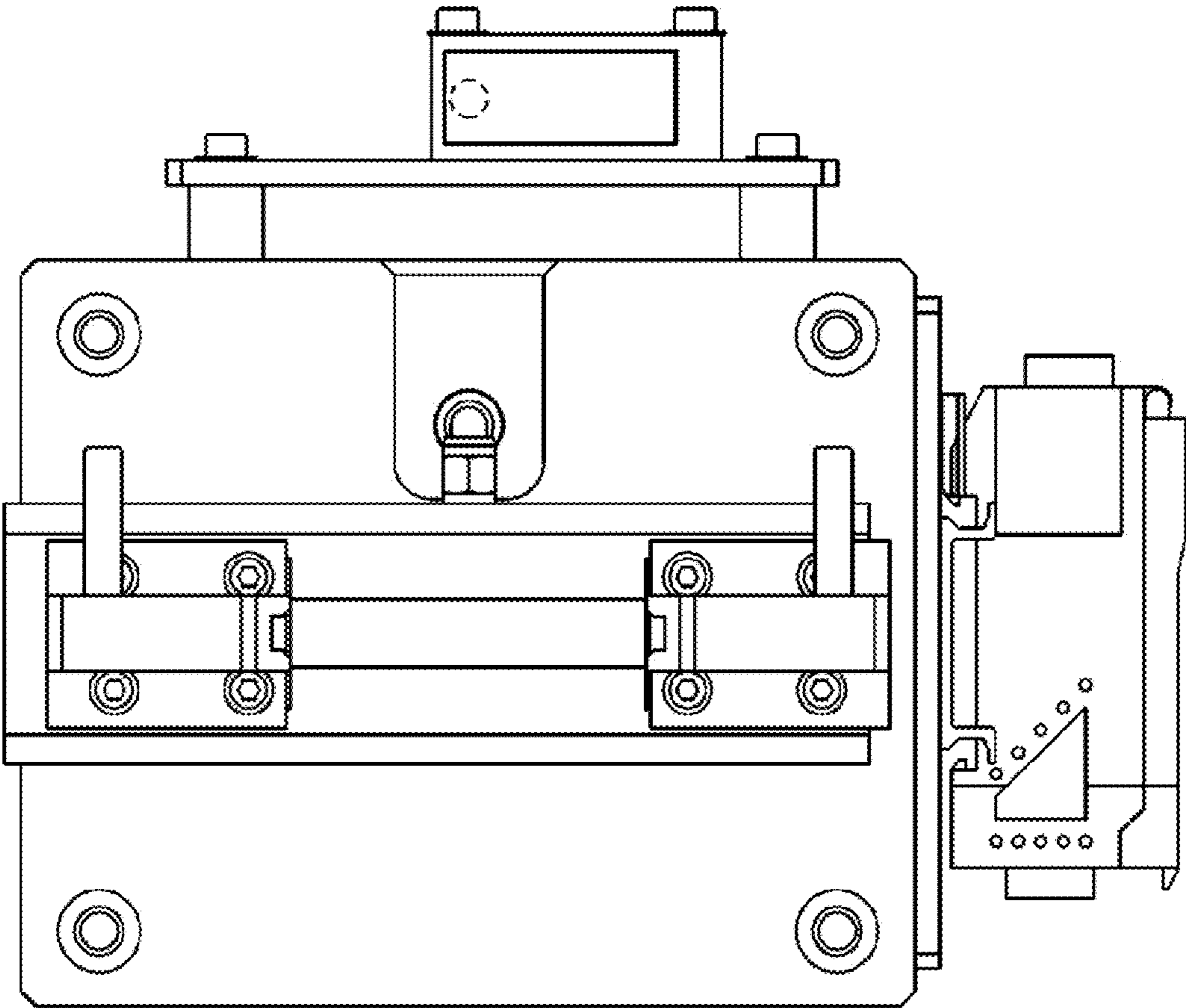

FIG. 9

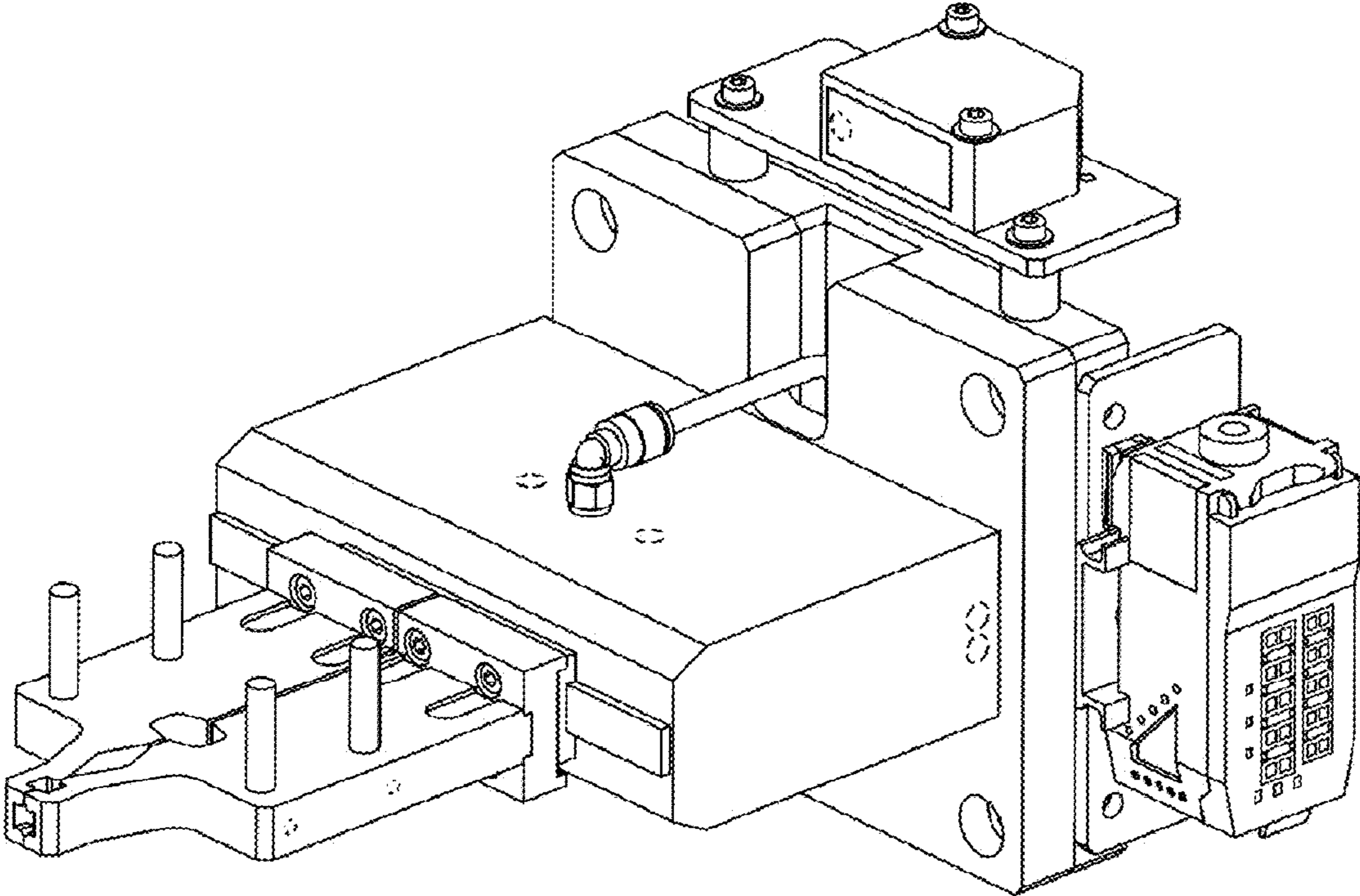

FIG. 10

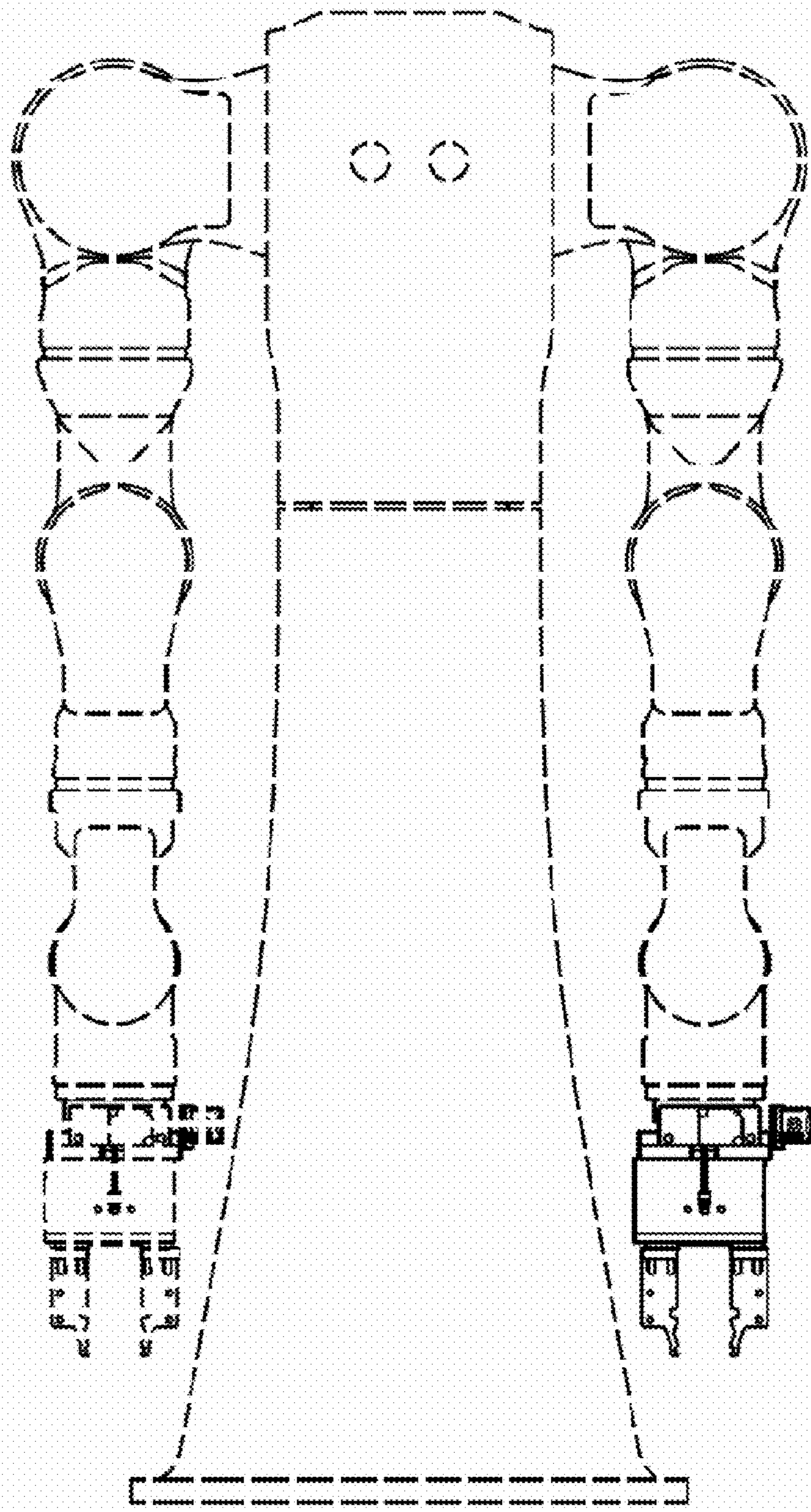

FIG. 11

