



US00D678308S

(12) **United States Design Patent**  
**Kanalakis, Jr. et al.**

(10) **Patent No.:** **US D678,308 S**  
(45) **Date of Patent:** **\*\* Mar. 19, 2013**

(54) **DISPLAY SCREEN WITH GRAPHICAL USER INTERFACE**

(75) Inventors: **John M. Kanalakis, Jr.**, San Jose, CA (US); **Beate Fritsch**, Oakland, CA (US); **Hal Rucker**, Hillsborough, CA (US); **Peter D. Andrea**, Oakland, CA (US)

(73) Assignee: **Cisco Technology, Inc.**, San Jose, CA (US)

(\*\*) Term: **14 Years**

(21) Appl. No.: **29/381,259**

(22) Filed: **Dec. 16, 2010**

(51) **LOC (9) Cl.** ..... **14-04**

(52) **U.S. Cl.** ..... **D14/486; D14/495**

(58) **Field of Classification Search** ..... D14/485-488; 715/751-753, 756, 758, 759, 772, 792, 808-809, 715/817, 821-822, 825, 833-834, 840-841, 715/843, 861, 864, 978; 348/14.03

See application file for complete search history.

(56) **References Cited**

U.S. PATENT DOCUMENTS

2,911,462 A	11/1959	Brady
3,793,489 A	2/1974	Sank
3,909,121 A	9/1975	de Mesquita Cardoso
4,400,724 A	8/1983	Fields
4,473,285 A	9/1984	Winter
4,494,144 A	1/1985	Brown
4,750,123 A	6/1988	Christian
4,815,132 A	3/1989	Minami
4,827,253 A	5/1989	Maltz
4,853,764 A	8/1989	Sutter
4,890,314 A	12/1989	Judd et al.
4,961,211 A	10/1990	Tsugane et al.
5,003,532 A	3/1991	Ashida et al.
5,020,098 A	5/1991	Celli
5,136,652 A	8/1992	Jibbe et al.
5,187,571 A	2/1993	Braun et al.
5,200,818 A	4/1993	Neta et al.

5,249,035 A	9/1993	Yamanaka
5,255,211 A	10/1993	Redmond
5,268,734 A	12/1993	Parker et al.
5,317,405 A	5/1994	Kuriki et al.
5,337,363 A	8/1994	Platt
5,347,363 A	9/1994	Yamanaka
5,359,362 A	10/1994	Lewis et al.
D357,468 S	4/1995	Rodd
5,406,326 A	4/1995	Mowry
5,423,554 A	6/1995	Davis
5,446,834 A	8/1995	Deering

(Continued)

FOREIGN PATENT DOCUMENTS

CN	101953158(A)	1/2011
CN	102067593	5/2011

(Continued)

OTHER PUBLICATIONS

U.S. Appl. No. 29/389,651, filed Apr. 14, 2011, entitled "Video Unit With Integrated Features," Inventor(s): Kyle A. Buzzard et al.

(Continued)

*Primary Examiner* — Karen E Kearney

(74) *Attorney, Agent, or Firm* — Patent Capital Group

(57) **CLAIM**

The ornamental design for an display screen with graphical user interface, as shown and described.

**DESCRIPTION**

FIG. 1 is a perspective view of a display screen with graphical user interface showing our new design; and, FIG. 2 is a front view thereof, the graphical user interface shown separate and enlarged for ease of illustration. The broken line showings of the display screen are for the purpose of illustrating environmental structure and form no part of the claimed design.

**1 Claim, 2 Drawing Sheets**

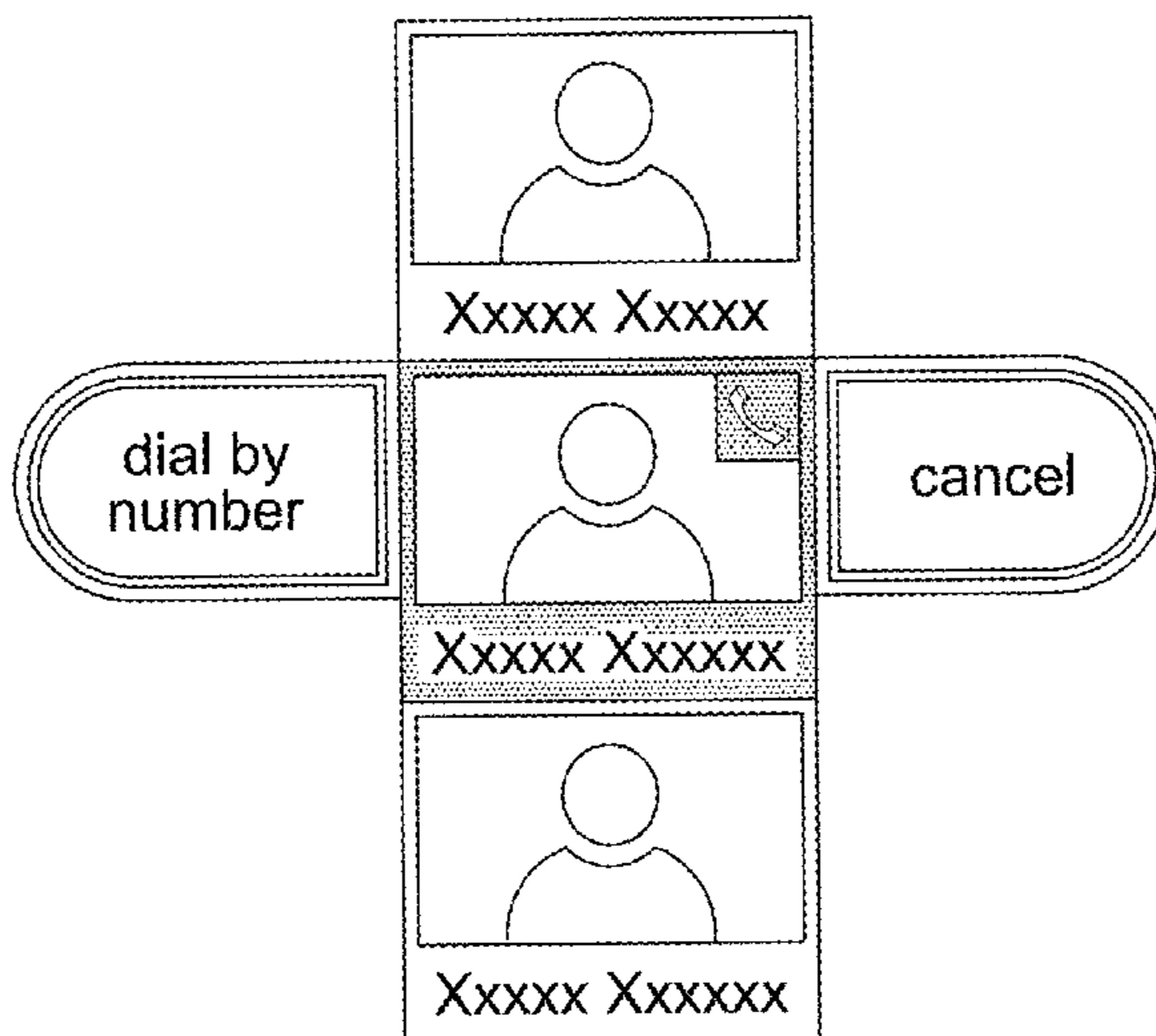

# US D678,308 S

U.S. PATENT DOCUMENTS							
5,448,287	A	9/1995	Hull	6,963,653	B1	11/2005	Miles
5,467,401	A	11/1995	Nagamitsu et al.	6,980,526	B2	12/2005	Jang et al.
5,495,576	A	2/1996	Ritchey	6,989,754	B2	1/2006	Kisacanin et al.
5,502,481	A	3/1996	Dentinger et al.	6,989,836	B2	1/2006	Ramsey
5,502,726	A	3/1996	Fischer	6,989,856	B2	1/2006	Firestone et al.
5,532,737	A	7/1996	Braun	6,990,086	B1	1/2006	Holur et al.
5,541,639	A	7/1996	Takatsuki et al.	7,002,973	B2	2/2006	MeLampy et al.
5,541,773	A	7/1996	Kamo et al.	7,028,092	B2	4/2006	MeLampy et al.
5,570,372	A	10/1996	Shaffer	7,031,311	B2	4/2006	MeLampy et al.
5,572,248	A	11/1996	Allen et al.	7,036,092	B2 *	4/2006	Sloo et al. .... 715/841
5,625,410	A	4/1997	Washino et al.	7,043,528	B2	5/2006	Schmitt et al.
5,666,153	A	9/1997	Copeland	7,057,636	B1	6/2006	Cohen-Solal et al.
5,675,374	A	10/1997	Kohda	7,057,662	B2	6/2006	Malzbender
5,715,377	A	2/1998	Fukushima et al.	7,061,896	B2	6/2006	Jabbari et al.
D391,935	S	3/1998	Sakaguchi et al.	7,080,157	B2	7/2006	McCanne
5,729,471	A	3/1998	Jain et al.	7,092,002	B2	8/2006	Ferren et al.
5,737,011	A	4/1998	Lukacs	7,111,045	B2	9/2006	Kato et al.
5,748,121	A	5/1998	Romriell	7,131,135	B1	10/2006	Virag et al.
5,760,826	A	6/1998	Nayar	7,136,651	B2	11/2006	Kalavade
5,790,182	A	8/1998	St. Hilaire	7,139,767	B1	11/2006	Taylor et al.
5,796,724	A	8/1998	Rajamani et al.	D533,525	S	12/2006	Arie
5,815,196	A	9/1998	Alshawi	D533,852	S	12/2006	Ma
5,818,514	A	10/1998	Duttweiler et al.	D534,511	S	1/2007	Maeda et al.
5,821,985	A	10/1998	Iizawa	D535,954	S	1/2007	Hwang et al.
D410,447	S	6/1999	Chang	7,158,674	B2	1/2007	Suh
5,940,118	A	8/1999	Van Schyndel	7,161,942	B2	1/2007	Chen et al.
5,940,530	A	8/1999	Fukushima et al.	7,164,435	B2 *	1/2007	Wang et al. .... 348/14.08
5,953,052	A	9/1999	McNelley et al.	D539,243	S	3/2007	Chiu et al.
5,956,100	A	9/1999	Gorski	D541,773	S	5/2007	Chong et al.
6,069,648	A *	5/2000	Suso et al. .... 348/14.02	D542,247	S	5/2007	Kinoshita et al.
6,101,113	A	8/2000	Paice	D545,314	S	6/2007	Kim
6,124,896	A	9/2000	Kurashige	7,246,118	B2	7/2007	Chastain et al.
6,148,092	A	11/2000	Qian	D548,742	S *	8/2007	Fletcher ..... D14/485
6,167,162	A	12/2000	Jacquin et al.	D550,635	S	9/2007	DeMaio et al.
6,172,703	B1	1/2001	Lee	D551,184	S	9/2007	Kanou et al.
6,173,069	B1	1/2001	Daly et al.	7,269,292	B2	9/2007	Steinberg
6,226,035	B1	5/2001	Korein et al.	7,274,555	B2	9/2007	Kim et al.
6,243,130	B1	6/2001	McNelley et al.	D555,610	S	11/2007	Yang et al.
6,249,318	B1	6/2001	Girod et al.	D561,130	S	2/2008	Won et al.
6,256,400	B1	7/2001	Takata et al.	7,336,299	B2	2/2008	Kostrzewski
6,266,082	B1 *	7/2001	Yonezawa et al. .... 348/159	D567,202	S	4/2008	Rieu Piquet
D446,790	S *	8/2001	Wang et al. .... D14/486	7,352,809	B2	4/2008	Wenger et al.
6,285,392	B1	9/2001	Satoda et al.	7,353,279	B2	4/2008	Durvasula et al.
6,292,188	B1 *	9/2001	Carlson et al. .... 715/854	7,353,462	B2 *	4/2008	Caffarelli ..... 715/825
6,292,575	B1	9/2001	Bortolussi et al.	7,359,731	B2	4/2008	Choksi
D450,323	S *	11/2001	Moore et al. .... D14/485	7,399,095	B2	7/2008	Rondinelli
6,356,589	B1	3/2002	Gebler et al.	7,411,975	B1	8/2008	Mohaban
6,424,377	B1	7/2002	Driscoll, Jr.	7,413,150	B1	8/2008	Hsu
6,430,222	B1	8/2002	Okada	7,428,000	B2	9/2008	Cutler et al.
6,459,451	B2	10/2002	Driscoll et al.	D578,496	S	10/2008	Leonard
6,462,767	B1 *	10/2002	Obata et al. .... 348/14.08	7,471,320	B2	12/2008	Malkin et al.
6,493,032	B1	12/2002	Wallerstein et al.	7,477,322	B2 *	1/2009	Hsieh ..... 348/569
6,507,356	B1	1/2003	Jackel et al.	7,477,657	B1	1/2009	Murphy et al.
6,583,808	B2	6/2003	Boulanger et al.	D588,560	S	3/2009	Mellingen et al.
6,590,603	B2	7/2003	Sheldon et al.	D591,306	S *	4/2009	Setiawan et al. .... D14/486
6,591,314	B1	7/2003	Colbath	7,518,051	B2	4/2009	Redmann
6,593,956	B1	7/2003	Potts et al.	D592,621	S	5/2009	Han
6,611,281	B2	8/2003	Strubbe	7,532,230	B2	5/2009	Culbertson et al.
6,680,856	B2	1/2004	Schreiber	7,532,232	B2	5/2009	Shah et al.
6,693,663	B1	2/2004	Harris	7,545,761	B1	6/2009	Kalbag
6,704,048	B1	3/2004	Malkin et al.	7,555,141	B2	6/2009	Mori
6,710,797	B1	3/2004	McNelley et al.	D602,033	S *	10/2009	Vu et al. .... D14/485
6,751,106	B2	6/2004	Zhang et al.	D602,453	S	10/2009	Ding et al.
6,768,722	B1	7/2004	Katseff et al.	7,616,226	B2	11/2009	Roessler et al.
6,771,303	B2	8/2004	Zhang et al.	D610,560	S	2/2010	Chen
6,774,927	B1	8/2004	Cohen et al.	7,661,075	B2 *	2/2010	Lahdesmaki ..... 715/841
6,795,108	B2	9/2004	Jarboe et al.	7,679,639	B2	3/2010	Harrell et al.
6,798,834	B1	9/2004	Murakami et al.	7,692,680	B2	4/2010	Graham et al.
6,806,898	B1	10/2004	Toyama et al.	7,707,247	B2	4/2010	Dunn et al.
6,807,280	B1	10/2004	Stroud et al.	D615,514	S	5/2010	Mellingen et al.
6,844,990	B2	1/2005	Artonne et al.	7,710,448	B2	5/2010	De Beer et al.
6,853,398	B2	2/2005	Malzbender et al.	7,710,450	B2	5/2010	Dhuey et al.
6,882,358	B1	4/2005	Schuster et al.	7,715,657	B2	5/2010	Lin et al.
6,888,358	B2	5/2005	Lechner et al.	7,719,605	B2	5/2010	Hirasawa et al.
6,909,438	B1	6/2005	White et al.	7,719,662	B2	5/2010	Bamji et al.
6,911,995	B2	6/2005	Ivanov et al.	7,720,277	B2	5/2010	Hattori
6,917,271	B2	7/2005	Zhang et al.	D626,102	S	10/2010	Buzzard et al.
6,922,718	B2	7/2005	Chang	D626,103	S	10/2010	Buzzard et al.
				D628,175	S	11/2010	Desai et al.

# US D678,308 S

D632,698 S *	2/2011	Judy et al. ....	D14/486	2007/0039030 A1	2/2007	Romanowich et al.	
7,889,851 B2	2/2011	Shah et al.		2007/0040903 A1	2/2007	Kawaguchi	
7,890,888 B2 *	2/2011	Glasgow et al. ....	715/811	2007/0070177 A1	3/2007	Christensen	
7,894,531 B1	2/2011	Cetin et al.		2007/0074123 A1 *	3/2007	Omura et al. ....	715/753
D634,753 S *	3/2011	Loretan et al. ....	D14/488	2007/0080845 A1	4/2007	Amand	
D635,569 S	4/2011	Park		2007/0112966 A1	5/2007	Eftis et al.	
D635,975 S	4/2011	Seo et al.		2007/0121353 A1	5/2007	Zhang et al.	
D638,853 S *	5/2011	Brinda .....	D14/488	2007/0140337 A1	6/2007	Lim et al.	
7,990,422 B2	8/2011	Ahiska et al.		2007/0153712 A1	7/2007	Fry et al.	
8,000,559 B2	8/2011	Kwon		2007/0157119 A1 *	7/2007	Bishop .....	715/810
D646,690 S *	10/2011	Thai et al. ....	D14/486	2007/0159523 A1	7/2007	Hillis et al.	
D649,556 S *	11/2011	Judy et al. ....	D14/486	2007/0162866 A1 *	7/2007	Matthews et al. ....	715/769
D656,513 S *	3/2012	Thai et al. ....	D14/487	2007/0192381 A1	8/2007	Padmanabhan	
8,135,068 B1	3/2012	Alvarez		2007/0206091 A1	9/2007	Dunn et al.	
8,179,419 B2	5/2012	Girish		2007/0206556 A1	9/2007	Yegani et al.	
2002/0106120 A1	8/2002	Brandenburg et al.		2007/0217406 A1	9/2007	Riedel et al.	
2002/0118890 A1	8/2002	Rondinelli		2007/0217500 A1	9/2007	Gao et al.	
2002/0131608 A1	9/2002	Lobb et al.		2007/0229250 A1	10/2007	Recker et al.	
2002/0140804 A1	10/2002	Colmenarez et al.		2007/0247470 A1	10/2007	Dhuey et al.	
2002/0149672 A1	10/2002	Clapp et al.		2007/0250567 A1	10/2007	Graham et al.	
2002/0186528 A1	12/2002	Huang		2007/0250620 A1	10/2007	Shah et al.	
2003/0017872 A1	1/2003	Oishi et al.		2007/0263079 A1	11/2007	Graham et al.	
2003/0048218 A1	3/2003	Milnes et al.		2008/0046840 A1 *	2/2008	Melton et al. ....	715/825
2003/0072460 A1	4/2003	Gonopolskiy et al.		2008/0077390 A1	3/2008	Nagao	
2003/0149724 A1	8/2003	Chang		2008/0136896 A1	6/2008	Graham et al.	
2003/0160861 A1	8/2003	Barlow et al.		2008/0151038 A1	6/2008	Khoury et al.	
2003/0179285 A1	9/2003	Naito		2008/0212677 A1	9/2008	Chen et al.	
2003/0185303 A1	10/2003	Hall et al.		2008/0215993 A1 *	9/2008	Rossman .....	715/753
2004/0038169 A1	2/2004	Mandelkern et al.		2008/0218582 A1	9/2008	Buckler	
2004/0061787 A1	4/2004	Liu et al.		2008/0240237 A1	10/2008	Tian et al.	
2004/0091232 A1	5/2004	Appling, III		2008/0240571 A1	10/2008	Tian et al.	
2004/0118984 A1	6/2004	Kim et al.		2008/0297586 A1	12/2008	Kurtz et al.	
2004/0119814 A1	6/2004	Clisham et al.		2008/0298571 A1	12/2008	Kurtz et al.	
2004/0164858 A1	8/2004	Lin		2008/0303901 A1	12/2008	Variyath et al.	
2004/0165060 A1	8/2004	McNelley et al.		2009/0009593 A1	1/2009	Cameron et al.	
2004/0178955 A1	9/2004	Menache et al.		2009/0012633 A1 *	1/2009	Liu et al. ....	700/90
2004/0189463 A1	9/2004	Wathen		2009/0037827 A1 *	2/2009	Bennetts .....	715/753
2004/0189676 A1	9/2004	Dischert		2009/0051756 A1	2/2009	Trachtenberg	
2004/0196250 A1	10/2004	Mehrotra et al.		2009/0122867 A1	5/2009	Mauchly et al.	
2004/0218755 A1	11/2004	Marton et al.		2009/0172596 A1 *	7/2009	Yamashita .....	715/834
2004/0246962 A1	12/2004	Kopeikin et al.		2009/0174764 A1	7/2009	Chadha et al.	
2004/0254982 A1	12/2004	Hoffman et al.		2009/0207233 A1	8/2009	Mauchly et al.	
2004/0260796 A1	12/2004	Sundqvist et al.		2009/0207234 A1	8/2009	Chen et al.	
2005/0007954 A1	1/2005	Sreemanthula et al.		2009/0244257 A1	10/2009	MacDonald et al.	
2005/0024484 A1	2/2005	Leonard		2009/0256901 A1	10/2009	Mauchly et al.	
2005/0034084 A1 *	2/2005	Ohtsuki et al. ....	715/864	2009/0322082 A1	12/2009	Wagoner	
2005/0050246 A1	3/2005	Lakkakorpi et al.		2009/0324023 A1	12/2009	Tian et al.	
2005/0081160 A1	4/2005	Wee et al.		2010/0005419 A1 *	1/2010	Miichi et al. ....	715/828
2005/0099492 A1 *	5/2005	Orr .....	348/14.08	2010/0030389 A1 *	2/2010	Palmer et al. ....	700/284
2005/0110867 A1	5/2005	Schulz		2010/0049542 A1 *	2/2010	Benjamin et al. ....	705/2
2005/0117022 A1	6/2005	Marchant		2010/0082557 A1	4/2010	Gao et al.	
2005/0129325 A1	6/2005	Wu		2010/0118112 A1	5/2010	Nimri et al.	
2005/0147257 A1	7/2005	Melchior et al.		2010/0123770 A1	5/2010	Friel et al.	
2005/0149872 A1 *	7/2005	Fong et al. ....	715/727	2010/0171807 A1	7/2010	Tysso	
2005/0154988 A1 *	7/2005	Proehl et al. ....	715/720	2010/0171808 A1	7/2010	Harrell et al.	
2005/0223069 A1 *	10/2005	Cooperman et al. ....	709/206	2010/0183199 A1	7/2010	Smith et al.	
2005/0248652 A1	11/2005	Firestone et al.		2010/0199228 A1	8/2010	Latta et al.	
2005/0268823 A1	12/2005	Bakker et al.		2010/0208078 A1	8/2010	Tian et al.	
2006/0017807 A1	1/2006	Lee et al.		2010/0225732 A1	9/2010	De Beer et al.	
2006/0028983 A1	2/2006	Wright		2010/0225735 A1	9/2010	Shaffer et al.	
2006/0048070 A1 *	3/2006	Taylor et al. ....	715/773	2010/0277563 A1	11/2010	Gupta et al.	
2006/0056056 A1	3/2006	Ahiska et al.		2010/0283829 A1	11/2010	De Beer et al.	
2006/0066717 A1	3/2006	Miceli		2010/0316232 A1	12/2010	Acero et al.	
2006/0082643 A1	4/2006	Richards		2011/0063467 A1	3/2011	Tanaka	
2006/0093128 A1	5/2006	Oxford		2011/0085016 A1	4/2011	Kristiansen et al.	
2006/0100004 A1	5/2006	Kim et al.		2011/0113348 A1 *	5/2011	Twiss et al. ....	715/753
2006/0104470 A1	5/2006	Akino		2011/0279627 A1 *	11/2011	Shyu .....	348/14.03
2006/0120307 A1	6/2006	Sahashi		2012/0120181 A1 *	5/2012	Kanalakis et al. ....	348/14.03
2006/0125691 A1	6/2006	Menache et al.		2012/0226997 A1 *	9/2012	Pang .....	715/753
2006/0126878 A1	6/2006	Takumai et al.					
2006/0152489 A1	7/2006	Sweetser et al.					
2006/0152575 A1	7/2006	Amiel et al.					
2006/0158509 A1	7/2006	Kenoyer et al.					
2006/0168302 A1	7/2006	Boskovic et al.					
2006/0170769 A1	8/2006	Zhou					
2006/0181607 A1	8/2006	McNelley et al.					
2006/0200518 A1	9/2006	Sinclair et al.					
2006/0256187 A1	11/2006	Sheldon et al.					
2006/0284786 A1	12/2006	Takano et al.					

## FOREIGN PATENT DOCUMENTS

EP	0 650 299	10/1994
EP	0 714 081	11/1995
EP	0 740 177	4/1996
EP	143745 A2	10/2001
EP	1 178 352 A1	6/2002
EP	1 589 758 A1	10/2005
EP	1701308 A2	9/2006
EP	1768058 A2	3/2007

EP	2073543	A1	6/2009
EP	2255531		12/2010
EP	22777308		1/2011
GB	2 294 605	A	5/1996
GB	2336266		10/1999
GB	2355876	A	5/2001
WO	WO 94/16517		7/1994
WO	WO 96/21321		7/1996
WO	WO 97/08896		8/1997
WO	WO 98/47291		10/1998
WO	WO 99/59026		11/1999
WO	WO 2001/033840		5/2001
WO	WO 2005/013001	A2	2/2005
WO	WO 2005/031001	A3	2/2005
WO	WO 2006/072755		7/2006
WO	WO2007/106157		9/2007
WO	WO 2007/123860	A2	11/2007
WO	WO2007/123946		11/2007
WO	WO 2007/123960	A3	11/2007
WO	WO 2008/039371		4/2008
WO	WO 2008/040258		4/2008
WO	WO 2008/101117	A1	8/2008
WO	WO 2008/118887	A2	10/2008
WO	WO 2008/118887	A3	10/2008
WO	WO 2009/102503	A2	8/2009
WO	WO 2009/102503	A3	8/2009
WO	WO 2009/120814	A2	10/2009
WO	WO 2009/120814	A3	10/2009
WO	WO 2010/059481		5/2010
WO	WO2010/096342		8/2010
WO	WO 2010/104765		9/2010
WO	WO 2010/132271		11/2010
WO	WO2012/033716		3/2012
WO	WO2012/068008		5/2012
WO	WO2012/068010		5/2012
WO	WO2012/068485		5/2012

OTHER PUBLICATIONS

U.S. Appl. No. 29/389,654, filed Apr. 14, 2011, entitled "Video Unit With Integrated Features," Inventor(s): Kyle A. Buzzard et al.

Boros, S., "Policy-Based Network Management with SNMP," Proceedings of the EUNICE 2000 Summer School Sep. 13-15, 2000, p. 3.

U.S. Appl. No. 13/096,772, filed Apr. 28, 2011, entitled "System and Method for Providing Enhanced Eye Gaze in a Video Conferencing Environment," Inventor(s): Charles C. Byers.

U.S. Appl. No. 13/106,002, filed May 12, 2011, entitled "System and Method for Video Coding in a Dynamic Environment," Inventors: Dihong Tian et al.

U.S. Appl. No. 13/098,430, filed Apr. 30, 2011, entitled "System and Method for Transferring Transparency Information in a Video Environment," Inventors: Eddie Collins et al.

U.S. Appl. No. 13/096,795, filed Apr. 28, 2011, entitled "System and Method for Providing Enhanced Eye Gaze in a Video Conferencing Environment," Inventors: Charles C. Byers.

EPO Feb. 25, 2011 Communication for EP09725288.6; 4 pages.

Cumming, Jonathan, "Session Border Control in IMS, An Analysis of the Requirements for Session Border Control in IMS Networks," Sections 1.1, 1.1.1, 1.1.3, 1.1.4, 2.1.1, 3.2, 3.3.1, 5.2.3 and pp. 7-8, Data Connection, 2005.

Jong-Gook Ko et al., "Facial Feature Tracking and Head Orientation-Based Gaze Tracking," ITC-CSCC 2000, International Technical Conference on Circuits/Systems, Jul. 11-13, 2000, 4 pages <http://www.umiacs.umd.edu/~knkim/paper/itc-csc-2000-jgko.pdf>.

Veratech Corp., "Phantom Sentinel," © VeratechAero 2006, 1 page; <http://www.veratechcorp.com/phantom.html>.

U.S. Appl. No. 12/950,786, filed Nov. 19, 2010, entitled "System and Method for Providing Enhanced Video Processing in a Network Environment," Inventor(s): David J. Mackie.

U.S. Appl. No. 29/381,245, filed Dec. 16, 2010, entitled "Interface Element," Inventor(s): John M. Kanalakis, Jr., et al.

U.S. Appl. No. 29/381,250, filed Dec. 16, 2010, entitled "Interface Element," Inventor(s): John M. Kanalakis, Jr., et al.

U.S. Appl. No. 29/381,254, filed Dec. 16, 2010, entitled "Interface Element," Inventor(s): John M. Kanalakis, Jr., et al.

U.S. Appl. No. 29/381,256, filed Dec. 16, 2010, entitled "Interface Element," Inventor(s): John M. Kanalakis, Jr., et al.

U.S. Appl. No. 29/381,260, filed Dec. 16, 2010, entitled "Interface Element," Inventor(s): John M. Kanalakis, Jr., et al.

U.S. Appl. No. 29/381,262, filed Dec. 16, 2010, entitled "Interface Element," Inventor(s): John M. Kanalakis, Jr., et al.

U.S. Appl. No. 29/381,264, filed Dec. 16, 2010, entitled "Interface Element," Inventor(s): John M. Kanalakis, Jr., et al.

Active8-3D—Holographic Projection—3D Hologram Retail Display & Video Project, [retrieved and printed on Feb. 24, 2009], [http://www.activ8-3d.co.uk/3d\\_holocubes](http://www.activ8-3d.co.uk/3d_holocubes); 1 page.

Andersson, L., et al., "LDP Specification," Network Working Group, RFC 3036, Jan. 2001, 133 pages; <http://tools.ietf.org/html/rfc3036>.

Arrington, Michael, "ejamming—Distributed Jamming," TechCrunch, Mar. 16, 2006; <http://www.techcrunch.com/2006/03/16/ejamming-distributed-jamming/>; 1 page.

Avrithis, Y., et al., "Color-Based Retrieval of Facial Images," European Signal Processing Conference (EUSIPCO '00), Tampere, Finland; Sep. 2000; <http://www.image.ece.ntua.gr/~ntsap/presentations/eusipco00.ppt#256>; 18 pages.

Awduche, D., et al., "Requirements for Traffic Engineering over MPLS," Network Working Group, RFC 2702, Sep. 1999, 30 pages; <http://tools.ietf.org/pdf/rfc2702.pdf>.

Bakstein, Hynek, et al., "Visual Fidelity of Image Based Rendering," Center for Machine Perception, Czech Technical University, Proceedings of the Computer Vision, Winer 2004, <http://www.benogo.dk/publications/Bakstein-Pajdla-CVWW04.pdf>; 10 pages.

Beesley, S.T.C., et al., "Active Macroblock Skipping in the H.264 Video Coding Standard," in Proceedings of 2005 Conference on Visualization, Imaging, and Image Processing—VIIP 2005, Sep. 7-9, 2005, Benidorm, Spain, Paper 480-261. ACTA Press, ISBN: 0-88986-528-0; 5 pages.

Berzin, O., et al., "Mobility Support Using MPLS and MP-BGP Signaling," Network Working Group, Apr. 28, 2008, 60 pages; <http://www.potaroo.net/ietf/all-ids/draft-berzin-malis-mppls-mobility-01.txt>.

Boccaccio, Jeff; CEPro, "Inside HDMI CEC: The Little-Known control Feature," Dec. 28, 2007; [http://www.cepro.com/article/print/inside\\_hdmi\\_cec\\_the\\_little\\_known\\_control\\_feature](http://www.cepro.com/article/print/inside_hdmi_cec_the_little_known_control_feature); 2 pages.

Bücken R: "Bildfernsehen: Videokonferenz vom Arbeitsplatz aus" Funkschau, Waxa Fachzeitschriften Verlag, Poing, DE, No. 17, Aug. 14, 1986, pp. 41-43, XP002537729; ISSN: 0016-2841, p. 43, left-hand column, line 34-middle column, line 24.

Chan, Eric, et al., "Experiments on block-matching techniques for video coding," Multimedia Systems; 9 Springer-Verlag 1994, Multimedia Systems (1994) 2 pages.

Chen et al., "Toward a Compelling Sensation of Telepresence: Demonstrating a Portal to a Distant (Static) Office," Proceedings Visualization 2000; VIS 2000; Salt Lake City, UT, Oct. 8-13, 2000, Annual IEEE Conference on Visualization, Los Alamitos, CA; IEEE Comp. Soc., US, Jan. 1, 2000, pp. 327-333; <http://citeseerx.ist.psu.edu/viewdoc/summary?doi=10.1.1.35.1287>.

Chen, Jason, "iBluetooth Lets iPhone Users Send and Receive Files Over Bluetooth," Mar. 13, 2009; <http://i.gizmodo.com/5169545/ibluetooth-lets-iphone-users-send-and-receive-files-over-bluetooth>; 1 page.

Chen, Qing, et al., "Real-time Vision-based Hand Gesture Recognition Using Haar-like Features," Instrumentation and Measurement Technology Conference, Warsaw, Poland, May 1-3, 2007, 6 pages; <http://www.google.com/url?sa=t&source=web&cd=1&ved=0CB4QFjAA&url=http%3A%2Fciteseerx.ist.psu.edu%2Fviewdoc%2Fdownload%3Fdoi%3D10.1.1.93.103%26rep%3Drep1%26type%3Dpdf&ei=A28RTLKRDefnQeXzZGRaw&usq=AFQjCNHpwj5MwjGp-3goVz5Wad6CO-Jzw>.

"Cisco Expo Germany 2009 Opening," Posted on YouTube on May 4, 2009; <http://www.youtube.com/watch?v=SDKsaS124MK>; 2 pages.

Cisco: Bill Mauchy and Mod Marathe; UNC; Henry Fuchs, et al., "Depth-Dependent Perspective Rendering," Apr. 15, 2008; 6 pages.

Costa, Cristina, et al., "Quality Evaluation and Nonuniform Compression of Geometrically Distorted Images Using the Quadtree Distortion Map," EURASIP Journal on Applied Signal Processing, Jan. 7, 2004, vol. 2004, No. 12; © 2004 Hindawi Publishing Corp.;

- XP002536356; ISSN: 1110-8657; pp. 1899-1911; <http://downloads.hindawi.com/journals/asp/2004/470826.pdf>.
- Criminisi, A., et al., "Efficient Dense-Stereo and Novel-view Synthesis for Gaze Manipulation in One-to-one Teleconferencing," Technical Rpt MSR-TR-2003-59, Sep. 2003 [retrieved and printed on Feb. 26, 2009], [http://research.microsoft.com/pubs/67266/criminisi\\_techrep2003-59.pdf](http://research.microsoft.com/pubs/67266/criminisi_techrep2003-59.pdf), 41 pages.
- "Custom 3D Depth Sensing Prototype System for Gesture Control," 3D Depth Sensing, GestureTek, 3 pages; [Retrieved and printed on Dec. 1, 2010] <http://www.gesturetek.com/3depth/introduction.php>.
- Daly, S., et al., "Face-based visually-optimized image sequence coding," Image Processing, 1998, ICIP 98. Proceedings; 1998 International Conference on Chicago, IL; Oct. 4-7, 1998, Los Alamitos; IEEE Computing; vol. 8, Oct. 4, 1998; ISBN: 978-0-8185-8821-8; XP010586786; pp. 443-447.
- Diaz, Jesus, "Zcam 3D Camera is Like Wii Without Wiimote and Minority Report Without Gloves," Dec. 15, 2007; <http://gizmodo.com/gadgets/zcam-depth-camera-could-be-wii-challenger/zcam-3d-camera-is-like-wii-without-wiimote-and-minority-report-without-gloves-334426.php>; 3pages.
- Diaz, Jesus, iPhone Bluetooth File Transfer Coming Soon (YES!); Jan. 26, 2009; <http://i.gizmodo.com/5138797/iphone-bluetooth-file-transfer-coming-soon-yes/>; 1page.
- DVE Digital Video Enterprises, "DVE Tele-Immersion Room," [Retrieved and printed on Feb. 5, 2009] [http://www.dvetelepresence.com/products/immersion\\_room.asp](http://www.dvetelepresence.com/products/immersion_room.asp); 2 pages.
- "Dynamic Displays," cooyright 2005-2008 [retrieved and printed on Feb. 24, 2009] [http://www.zebraimaging.com/html/lighting\\_display.html](http://www.zebraimaging.com/html/lighting_display.html), 2 pages.
- ECmag.com, "IBS Products," Published Apr. 2009; <http://www.ecmag.com/index.cfm?fa=article&articleID=10065>; 2 pages.
- eJamming Audio, Learn More; [retrieved and printed on May 27, 2010] <http://www.ejamming.com/learnore/>; 4 pages.
- Electrophysics Glossary, "Infrared Cameras, Thermal Imaging, Night Vision, Roof Moisture Detection," [retrieved and printed on Mar. 18, 2010] [http://www.electrophysics.com/Browse/Brw\\_Glossary.asp](http://www.electrophysics.com/Browse/Brw_Glossary.asp); 11 pages.
- Farrukh, A., et al., Automated Segmentation of Skin-Tone Regions in Video Sequences, Proceedings IEEE Students Conference, ISCON\_apos\_02; Aug. 16-17, 2002; pp. 122-128.
- Fiala, Mark, "Automatic Projector Calibration Using Self-Identifying Patterns," National Research Council of Canada, Jun. 20-25, 2005; <http://www.procams.org/procams2005/papers/procams05-36.pdf>; 6 pages.
- Foote, J., et al., "Flycam: Practical Panoramic Video and Automatic Camera Control," in Proceedings of IEEE International Conference on Multimedia and Expo, vol. III, Jul. 30, 2000; pp. 1419-4422; <http://citeseerx.ist.psu.edu/viewdoc/versions?doi=10.1.1.138.8686>.
- Freeman, Professor Wilson T., Computer Vision Lecture Slides, "6.869 Advances in Computer Vision: Learning and Interfaces," Spring 2005; 21 pages.
- Gemmell, Jim, et al., "Gaze Awareness for Video-conferencing: A Software Approach," IEEE MultiMedia, Oct.-Dec. 2000; vol. 7, No. 4, pp. 26-35.
- Gotchev, Atanas, "Computer Technologies for 3D Video Delivery for Home Entertainment," International Conference on Computer Systems and Technologies; CompSysTech, Jun. 12-13, 2008; <http://ecet.ecs.ru.acad.bg/cst08/docs/cp/Plenary.pdf>; 6 pages.
- Gries, Dan, "3D Particles Experiments in AS3 and Flash C53, Dan's Comments," [retrieved and printed on May 24, 2010] <http://www.flashandmath.com/advanced/fourparticles/notes.html>; 3 pages.
- Guernsey, Lisa, "Toward Better Communication Across the Language Barrier," Jul. 29, 1999; <http://www.nytimes.com/1999/07/29/technology/toward-better-communication-across-the-language-barrier.html>; 2 pages.
- Guili, D., et al., "Orchestral: A Distributed Platform for Virtual Musical Groups and Music Distance Learning over the Internet in Java™ Technology"; [retrieved and printed on Jun. 6, 2010] <http://ieeexplore.ieee.org/stamp/stamp.jsp?tp=&arnumber=778626>; 2 pages.
- Gundavelli, S., et al., "Proxy Mobile IPv6," Network Working Group, RFC 5213, Aug. 2008, 93 pages; <http://tools.ietf.org/pdf/rfc5213.pdf>.
- Habill, Nariman, et al., "Sermentation of the Face and Hands in Sign Language Video Sequences Using Color and Motion Cues" IEEE Transaction on Circuits and Systems for Video Technology, IEEE Service Center, vol. 14, No. 8, Aug. 1, 2004; ISSN: 1051-8215; XP011115755; pp. 1086-1097.
- He, L, et al., "The Virtual Cinematographer: A Paradigm for Automatic Real-Time Camera Control and Directing," Proc. SIGGRAPH, © 1996; <http://research.microsoft.com/en-us/um/people/ihe/papers/siggraoh96.vc.pdf>; 8 pages.
- Hepper, D., "Efficiency Analysis and Application of Uncovered Background Prediction in a Low BitRate Image Coder," IEEE Transactions on Communications, vol. 38, No. 9, pp. 1578-1584, Sep. 1990.
- Holographic Imaging, "Dynamic Holography for scientific uses, military heads up display and even someday HoloTV Using TI's DMD," [retrieved and printed on Feb. 26, 2009] [http://innovotion.swmed.edu/research/instrumentation/res\\_inst\\_dev3d.html](http://innovotion.swmed.edu/research/instrumentation/res_inst_dev3d.html); 5 pages.
- Hornbeck, Larry J., "Digital Light Processing™: A New MEMS-Based Display Technology," [retrieved and printed on Feb. 26, 2009] [http://focus.ti.com/pdfs/dlpdmd/17\\_Digital\\_Light\\_Processing\\_MEMS\\_display\\_technology.pdf](http://focus.ti.com/pdfs/dlpdmd/17_Digital_Light_Processing_MEMS_display_technology.pdf); 22 pages.
- "Infrared Cameras TVS-200-EX," [retrieved and printed on May 24, 2010] [http://www.electrophysics.com/Browse/Brw\\_ProductLineCategory.asp?CategoryID=184&Area=IS](http://www.electrophysics.com/Browse/Brw_ProductLineCategory.asp?CategoryID=184&Area=IS); 2 pages.
- IR Distribution Category @ Envious Technology, "IR Distribution Category," [retrieved and printed on Apr. 22, 2009] <http://www.envioustechnology.com.au/products/product-list.php?CID=305>; 2 pages.
- IR Trans—Products and Orders—Ethernet Devices, [retrieved and printed on Apr. 22, 2009] <http://www.irtrans.de/en/shop/ian.php>; 2 pages.
- Isgro, Francesco et al., "Three-Dimensional Image Processing in the Future of Immersive Media," IEEE Transactions on Circuits and Systems for Video Technology, vol. 14, No. 3; XP011108796; ISSN: 1051-8215; Mar. 2004; pp. 288-303.
- Itoh, Hiroyasu, et al., "Use of a gain modulating framing camera for time-resolved imaging of cellular phenomena," SPIE vol. 2979, 1997, pp. 733-740.
- Jamoussi, Bamil, "Constraint-Based LSP Setup Using LDP," MPLS Working Group, Sep. 1999, 34 pages; <http://tools.ietf.org/html/draft-ietf-mpls-cr-idp-03>.
- Jeyatharan, M., et al., "3GPP TFT Reference for Flow Binding," MEXT Working Group, Mar. 2, 2010, 11 pages; <http://www.ietf.orr/id/draft-jevatharan-mext-flow-tftemp-reference-00.txt>.
- Jiang, Minqiang, et al., "On Lagrange Multiplier and Quantizer Adjustment for H.264 Frame-layer Video Rate Control," IEEE Transactions on Circuits and Systems for Video Technology, vol. 16, Issue 5, May 2006, pp. 663-669.
- Kannangara, C.S., et al., "Complexity Reduction of H.264 Using Lagrange Multiplier Methods," IEEE Int. Conf. on Visual Information Engineering, Apr. 2005; [www.rgu.ac.uk/files/h264\\_complexity\\_kannangara.pdf](http://www.rgu.ac.uk/files/h264_complexity_kannangara.pdf); 6 pages.
- Kannangara, C.S., et al., "Low Complexity Skip Prediction for H.264 through Lagrangian Cost Estimation," IEEE Transactions on Circuits and Systems for Video Technology, vol. 16, No. 2, Feb. 2006; [www.rgu.ac.uk/files/h264\\_skippredict\\_richardson\\_final.pdf](http://www.rgu.ac.uk/files/h264_skippredict_richardson_final.pdf); 20 pages.
- Kauff, Peter, et al., "An Immersive 3D Video-Conferencing System Using Shared Virtual Team User Environments," Proceedings of the 4th International Conference on Collaborative Environments, XP040139458; Sep. 30, 2002; [http://ip.hhi.de/media\\_G3/assets/pdfs/CVE02.pdf](http://ip.hhi.de/media_G3/assets/pdfs/CVE02.pdf); 8 pages.
- Kazutake, Uehira, "Simulation of 3D image depth perception in a 3D display using two stereoscopic displays at different depths," Jan. 30, 2006; <http://adsabs.harvard.edu/abs/2006SPIE.5055.408U>; 2 pages.
- Keijser, Jeroen, et al., "Exploring 3D Interaction in Alternate Control-Display Space Mappings," Symposium on 3D User Interfaces, Mar. 10-11, 2007, pp. 17-24.
- Kim, Y.H., et al., "Adaptive mode decision for H.264 encoder," Electronics letters, vol. 40, Issue 19, pp. 1172-1173, Sep. 2004; 2 pages.
- Klint, Josh, "Deferred Rendering in Leadwerks Engine," Copyright Leadwerks Corporation © 2008; [http://www.leadwerks.com/files/Deferred\\_Rendering\\_in\\_Leadwerks\\_Engine.pdf](http://www.leadwerks.com/files/Deferred_Rendering_in_Leadwerks_Engine.pdf); 10 pages.

- Kolsch, Mathias, "Vision Based Hand Gesture Interfaces for Wearable Computing and Virtual Environments," A Dissertation submitted in partial satisfaction of the requirements for the degree of Doctor of Philosophy in Computer Science, University of California, Santa Barbara, Nov. 2004, 288 pages; <http://fulfillment.umi.com/dissertations/b7afbcb56ba72fdb14d26dfccc8b470f/1291487062/3143800.pdf>.
- Koyama, S., et al., "A Day and Night Vision MOS Imager with Robust Photonic-Crystal-Based RGB-and-IR," Mar. 2008, pp. 754-759, ISSN: 0018-9383; IEE Transactions on Electron Devices, vol. 55, No. 3; <http://ieeexplore.ieee.org/stamp/stamp.jsp?tp=&arnumber=4455782&isnumber=4455723>.
- Lawson, S., "Cisco Plans TelePresence Translation Next Year," Dec. 9, 2008; [http://www.pcworld.com/article/155237/.html?tk=rss\\_news](http://www.pcworld.com/article/155237/.html?tk=rss_news); 2 pages.
- Lee, J, and Jeon, B., "Fast Mode Decision for H.284," ISO/IEC MPEG and ITU-T VCEG Joint Video Team, Doc. JVT-1033, Dec. 2003; [http://media.skku.ac.kr/publications/paper/IntC/ljy\\_ICME2004.pdf](http://media.skku.ac.kr/publications/paper/IntC/ljy_ICME2004.pdf); 4 pages.
- Liu, Z., "Head-Size Equalization for Better Visual Perception of Video Conferencing," Proceedings, IEEE International Conference on Multimedia & Expo (ICME2005), Jul. 6-8, 2005, Amsterdam, The Netherlands; <http://research.microsoft.com/users/cohen/HeadSizeEqualizationICME2005.pdf>; 4 pages.
- Mann, S., et al., "Virtual Bellows: Constructing High Quality Still from Video," Proceedings, First IEEE International Conference on Image Processing ICIP-94, Nov. 13-16, 1994, Austin, TX; <http://citeseerx.ist.psu.edu/viewdoc/summary?doi=10.1.1.50.8405>; 5 pages.
- Marvin Imaging Processing Framework, "Skin-colored pixels detection using Marvin Framework" video clip, YouTube, posted Feb. 9, 2010 by marvinproject, 1 page; <http://www.youtube.com/user/marvinproject#p/a/u/0/3ZuQHYNicrl>.
- Miller, Gregor, et al., "Interactive Free-Viewpoint Video," Centre for Vision, Speech and Signal Processing, [retrieved and printed on Feb. 26, 2009], <http://www.ee.surrey.ac.uk/CVSSP/VMRG/Publications/milier05cvmp.pdf>, 10 pages.
- Miller, Paul, "Microsoft Research patents controller-free computer input via EMG muscle sensors," Engadget.com, Jan. 3, 2010, 1 page; <http://www.engadget.com/2010/01/03/microsoft-research-patents-controller-free-computer-input-via-em/>.
- "Minoru from Novo is the worlds first consumer 3D Webcam," Dec. 11, 2008; <http://www.minoru3d.com>; 4 pages.
- Mitsubishi Electric Research Laboratories, copyright 2009 [retrieved and printed on Feb. 26, 2009], <http://www.merl.com/projects/3dvt>, 2 pages.
- National Training Systems Association Home—Main, Interservice/Industry Training Education Conference, Dec. 1-4, 2008; <http://ntsa.metapress.com/app/home/main.asp?referrer=default>; 1 page.
- Oh, Hwang-Seok, et al., "Block-Matching Algorithm Based on Dynamic Search Window Adjustment," Dept. of CS, KAIST, 1997, 6 pages; <http://citeseerx.ist.psu.edu/viewdoc/similar?doi=10.1.1.29.862.1&type=ab>.
- Opera Over Cisco TelePresence at Cisco Expo 2009, in Hannover Germany—Apr. 28, 29, posted on YouTube on May 5, 2009; <http://www.youtube.com/watch?v=xNSJNHSE-38>; 1 page.
- OptoIQ, "Vision + Automation Products—VideometerLab 2," [retrieved and printed on Mar. 18, 2010], <http://www.optoiq.com/optoiq-2/en-us/index/machine-vision-imaging-processing/display/vsd-articles-tools-template.articles.vision-systems-design.volume-11.issue-10.departments.new-products.vision-automation-products.htmlhtml>; 11 pages.
- OptoIQ, "Anti-Speckle Techniques Uses Dynamics Optics," Jun. 1, 2009; <http://www.optoiq.com/index/photronics-technologies-applications/lfw-display/lfw-article-display/363444/articles/optoiq2/photronics-technologies/technology-products/optical-components/optical-mems/2009/12/anti-speckle-technique-uses-dynamic-optics/QP129867/cmpid=EnIOptoLFWJanuary132010.html>; 2 pages.
- OptoIQ, "Smart Camera Supports Multiple Interfaces," Jan. 22, 2009; <http://www.optoiq.com/index/machine-vision-imaging-pro-cessing/display/vsd-article-display/350639/articles/vision-systems-design/daily-product-2/2009/01/smart-camera-supports-multiple-interfaces.html>; 2 pages.
- OptoIQ, "Vision Systems Design—Machine Vision and Image Processing Technology," [retrieved and printed on Mar. 18, 2010], <http://www.optoiq.com/index/machine-vision-imaging-processing.html>; 2 pages.
- Payatagool, Chris, "Orchestral Manoeuvres in the Light of Telepresence," Telepresence Options, Nov. 12, 2008; [http://www.telepresenceoptions.com/2008/11/orchestral\\_manoeuvres](http://www.telepresenceoptions.com/2008/11/orchestral_manoeuvres); 2 pages.
- PCT International Preliminary Report on Patentability mailed Aug. 26, 2010 for PCT/US2009/001070; 10 pages.
- PCT International Report of Patentability dated May 15, 2006, for PCT International Application PCT/US2004/021585; 6 pages.
- PCT International Search Report mailed Aug. 24, 2010 for PCT/US2010033880; 4 pages.
- PCT Notification of Transmittal of the International Search Report and the Written Opinion of the International Searching Authority, or the Declaration for PCT/US2009/064061 mailed Feb. 23, 2010; 14 pages.
- Pixel Tools "Rate Control and H.264; H.264 rate control algorithm dynamically adjusts encoder parameters," [retrieved and printed on Jun. 10, 2010] [http://www.pixeltools.com/rate\\_control\\_paper.html](http://www.pixeltools.com/rate_control_paper.html); 7 pages.
- Radhika, N., et al., "Mobile Dynamic reconfigurable Context aware middleware for Adhoc smart spaces," vol. 22, 2008; <http://www.acadjournal.com/2008/V22/part6/p7>; 3 pages.
- Rayvel Business-to-Business Products, copyright 2004 [retrieved and printed on Feb. 24, 2009], <http://www.rayvel.com/b2b.html>; 2 pages.
- "Real-time Hand Motion/Gesture Detection for HCI-Demo 2," video clip, YouTube, posted Dec. 17, 2008 by smmy0705, 1 page; [www.youtube.com/watch?v=mLT4CFLII&A&feature=related](http://www.youtube.com/watch?v=mLT4CFLII&A&feature=related).
- Richardson, I.E.G., et al., "Fast H.264 Skip Mode Selection Using and Estimation Framework," Picture Coding Symposium, (Beijing, China), Apr. 2006; [www.rgu.ac.uk/files/richardson\\_fast\\_skip\\_estimation\\_pcs06.pdf](http://www.rgu.ac.uk/files/richardson_fast_skip_estimation_pcs06.pdf); 6 pages.
- Richardson, Iain, et al., "Video Encoder Complexity Reduction by Estimating Skip Mode Distortion," Image Communication Technology Group; [Retrieved and printed Oct. 21, 2010] 4 pages; [http://www4.rgu.ac.uk/file/ICIP04\\_richardson\\_zhao\\_final.pdf](http://www4.rgu.ac.uk/file/ICIP04_richardson_zhao_final.pdf).
- "Robust Face Localisation Using Motion, Colour & Fusion"; Proc. VIIth Digital Image Computing; Techniques and Applications, Sun C. et al (Eds.), Sydney; XP007905630; pp. 899-908; Dec. 10, 2003; <http://www.cmis.csiro.au/Hugues.Talbot/dicta2003/cdrom/pdf/0899.pdf>.
- Satoh, Kiyohide et al., "Passive Dept Acquisition for 3D Image Displays", IEICE Transactions on Information and Systems, Information Systems Society, Tokyo, JP, Sep. 1, 1994, vol. E77-D, No. 9, pp. 949-957.
- School of Computing, "Bluetooth over IP for Mobile Phones," 2005; [http://www.computing.dcu.ie/wwwadmin/fyp-abstract/list/lyp\\_details08.jsp?year=2005&number=51470574](http://www.computing.dcu.ie/wwwadmin/fyp-abstract/list/lyp_details08.jsp?year=2005&number=51470574); 1 page.
- Schroeder, Erica, "The Next Top Model—Collaboration," Collaboration, The Workspace: A New World of Communications and Collaboration, Mar. 9, 2009; [http://blogs.cisco.com/collaboration/comments/the\\_next\\_top\\_model](http://blogs.cisco.com/collaboration/comments/the_next_top_model); 3 pages.
- SENA, "Industrial Bluetooth," [retrieved and printed on Apr. 22, 2009] [http://www.sena.com/products/industrial\\_bluetooth](http://www.sena.com/products/industrial_bluetooth); 1 page.
- Shaffer, Shmuel, "Translation—State of the Art" presentation; Jan. 15, 2009; 22 pages.
- Shi, C. et al., "Automatic Image Quality Improvement for Videoconferencing," IEEE ICASSP May 2004; <http://research.microsoft.com/pubs/69079/0300701.pdf>; 4 pages.
- Shum, H.-Y., et al., "A Review of Image-Based Rendering Techniques," in SPIE Proceedings vol. 4067(3); Proceedings of the Conference on Visual Communications and Image Processing 2000, Jun. 20-23, 2000, Perth, Australia; pp. 2-13; [https://research.microsoft.com/pubs/68826/review\\_image\\_rendering.pdf](https://research.microsoft.com/pubs/68826/review_image_rendering.pdf).
- "Simple Hand Gesture Recognition," video clip, YouTube, posted Aug. 25, 2008 by pooh8210, 1 page; <http://www.youtube.com/watch?v=F9GVeV0dYLM&feature=related>.

- Smarthome, "IR Extender Expands Your IR Capabilities," [retrieved and printed on Apr. 22, 2009], <http://www.smarthome.com/8121.html>; 3 pages.
- Soliman, H., et al., "How Bindings in Mobile IPv6 and NEMO Basic Support," IETF MEXT Working Group, Nov. 9, 2009, 38 pages; <http://tools.ietf.org/html/draft-ietf-mext-flow-binding-04>.
- Sonoma Wireworks Forums, "Jammin on RiffLink," [retrieved and printed on May 27, 2010] <http://www.sonomawireworks.com/forums/viewtopic.php?id=2659>; 5 pages.
- Sonoma Wireworks RiffLink, [retrieved and printed on Jun. 2, 2010] <http://www.sonomawireworks.com/riffLink.php>; 3 pages.
- SooHuan, Kim, et al., "Block-based face detection scheme using face color and motion estimation," Real-Time Imaging VIII; Jan. 20-22, 2004, San Jose, CA; vol. 5297, No. 1; Proceedings of the SPIE—The International Society for Optical Engineering SPIE-Int. Soc. Opt. Eng USA ISSN: 0277-786X; XP007905596; pp. 78-88.
- Sudan, Ranjeet, "Signaling in MPLS Networks with RSVP-TE-Technology Information," Telecommunications, Nov. 2000, 3 pages; [http://findarticles.com/p/articles/mi\\_mTLC/is\\_11\\_34/al\\_57447072/](http://findarticles.com/p/articles/mi_mTLC/is_11_34/al_57447072/).
- Sullivan, Gary J., et al., "Video Compression—From Concepts to the H.264/AVS Standard," Proceedings IEEE, vol. 93, No. 1, Jan. 2005; [http://ip.hhi.de/imagecom\\_G1/assets/pdfs/piece\\_sullivan\\_wiegand\\_200S.pdf](http://ip.hhi.de/imagecom_G1/assets/pdfs/piece_sullivan_wiegand_200S.pdf); 14 pages.
- Sun, X., et al., "Region of Interest Extraction and Virtual Camera Control Based on Panoramic Video Capturing," IEEE Trans, Multimedia, Oct. 27, 2003; <http://vision.ece.ucsb.edu/publications/04mmXdsun.pdf>; 14 pages.
- Super Home Inspectors or Super Inspectors, [retrieved and printed on Mar. 18, 2010] <http://www.umrt.com/PageManager/Default.aspx/PageID=2120325>; 3 pages.
- Total immersion, Video Gallery, copyright 2008-2009 [retrieved and printed on Feb. 26, 2009], <http://www.1-immersion.com/en,video-gallery,36.html>, 1 page.
- Trucco, E., et al., "Real-Time Disparity Maps for Immersive 3-D Teleconferencing by Hybrid Recursive Matching and Census Transform," [retrieved and printed on May 4, 2010] <http://server.cs.ucf.edu/~vision/papers/VidReg-final.pdf>; 9 pages.
- Tsatsoulis, N., et al., "Face Detection for Multimedia Applications," Proceedings of the ICIP Sep. 10-13, 2000, Vancouver, BC, Canada; vol. 2, pp. 247-250.
- Tsatsoulis, N., et al., "Face Detection in Color Images and Video Sequences," 10th Mediterranean Electrotechnical Conference (MELECON), May 29-31, 2000; vol. 2; pp. 498-502.
- Wachs, J., et al., "A Real-time Hand Gesture System Based on Evolutionary Search," Vision, 3<sup>rd</sup> Quarter 2006, vol. 22, No. 3, 18 pages; <http://web.ics.purdue.edu/~jpwachs/papers/3q06vi.pdf>.
- Wang, Hualu, et al., "A Highly Efficient System for Automatic Face Region Detection in MPEG Video," IEEE Transactions on Circuits and Systems for Video Technology; vol. 7, Issue 4; 1977 pp. 615-628.
- Wang, Robert and Jovan Popovic, "Real-Time Hand-Tracking with a Color Glove, ACM Transaction on Graphics" (SIGGRAPH 2009), 28(3), Aug. 2009; 8 pages <http://people.csail.mit.edu/rywang/handtracking/s09-hand-tracking.pdf>.
- Wang, Robert and Jovan Popovic, "Real-Time Hand-Tracking with a Color Glove, ACM Transaction on Graphics," 4 pages, [Retrieved and printed on Dec. 1, 2010] <http://people.csail.mit.edu/rywang/hand>.
- Wang, Robert and Jovan Popovic, "Gestural user input," video clip, YouTube, posted by rkeltset on May 19, 2010, 1 page; <http://www.youtube.com/watch?v=3JWYtTBJdTE>.
- Wang, Robert and Jovan Popovic, "Tracking the 3D pose and configuration of the hand," video clip, YouTube, posted by rkeltset on Mar. 31, 2010, 1 page; <http://www.youtube.com/watch?v=J0XwJkWP65w>.
- Wang, Robert and Jovan Popovic, "Desktop virtual reality," video clip, YouTube, posted by rkeltset on Apr. 8, 2010, 1 page; <http://www.youtube.com/watch?v=9rBtm62Lkfk>.
- Wang, Robert and Jovan Popovic, "Bimanual and scaling," video clip, YouTube, posted by rkeltset on Apr. 14, 2010, 1 page; <http://www.youtube.com/watch?v=7TPFSCX79U>.
- Wang, Robert and Jovan Popovic, "Manipulating a virtual yoke," video clip, YouTube, posted by rkeltset on Jun. 8, 2010, 1 page; <http://www.youtube.com/watch?v=UfgGOO2uM>.
- Westerink, P.H., et al., "Two-pass MPEG-2 variable-bitrate encoding," IBM Journal of Research and Development, Jul. 1991, Vol. 43, No. 4; <http://citeseerx.ist.psu.edu/viewdoc/summary?doi=10.1.1.128.421>; 18 pages.
- Wiegand, T., et al., "Efficient mode selection for block-based motion compensated video coding," Proceedings, 2005 International Conference on Image Processing IIP 2005, pp. 2559-2562; [citeseer.ist.psu.edu/wiegand95efficient.html](http://citeseer.ist.psu.edu/wiegand95efficient.html).
- Wiegand, T., et al., "Rate-distortion optimized mode selection for very low bit rate video coding and the emerging H.263 standard," IEEE Trans. Circuits Syst. Video Technol., Apr. 1996, vol. 6, No. 2, pp. 182-190.
- Wi-Fi Protected Setup, from Wikipedia, Sep. 2, 2010, 3 pages [http://en.wikipedia.org/wiki/Wi-Fi\\_Protected\\_Setup](http://en.wikipedia.org/wiki/Wi-Fi_Protected_Setup).
- Wilson, Mark, "Dreamoc 3D Display Turns Any Phone Into Hologram Machine," Oct. 30, 2008; <http://gizmodo.com/5070906/dreamoc-3d-display-turns-any-phone-into-hologram-machine>; 2 pages.
- WirelessDevNet, Melody Launches Bluetooth Over IP, [retrieved and printed on Jun. 5, 2010] <http://www.wirelessdevnet.com/news/2001/155/news5.html>; 2 pages.
- Xia, F., et al., "Home Agent Initiated Flow Binding for Mobile IPv6," Network Working Group, Oct. 19, 2009, 15 pages; <http://tools.ietf.org/html/draft-xia-mext-ha-init-flow-binding-01.txt>.
- Xin, Jun, et al., "Efficient macroblock coding-mode decision for H.264/AVC video coding," Technical Report MERL 2004-079, Mitsubishi Electric Research Laboratories, Jan. 2004; [www.merl.com/publications/TR2004-079/](http://www.merl.com/publications/TR2004-079/); 12 pages.
- Yang, Jie, et al., "A Real-Time Face Tracker," Proceedings 3rd IEEE Workshop on Applications of Computer Vision; 1996; Dec. 2-4, 1996; pp. 142-147; [http://www.ri.cmu.edu/pub\\_files/pub1/yang\\_jie\\_1996\\_1/yang\\_jie\\_1996\\_1.pdf](http://www.ri.cmu.edu/pub_files/pub1/yang_jie_1996_1/yang_jie_1996_1.pdf).
- Yang, Ming-Hsuan, et al., "Detecting Faces in Images: A Survey," vol. 24, No. 1; Jan. 2002; pp. 34-58; <http://vision.al.uiuc.edu/mhyang/papers/pami02a.pdf>.
- Yang, Ruigang, et al., "Real-Time Consensus-Based Scene Reconstruction using Commodity Graphics Hardware," Department of Computer Science, University of North Carolina at Chapel Hill; 2002; [http://www.cs.unc.edu/Research/stc/publications/yang\\_pacigra2002.pdf](http://www.cs.unc.edu/Research/stc/publications/yang_pacigra2002.pdf); 10 pages.
- Yang, Xiaokang, et al., Rate Control for H.264 with Two-Step Quantization Parameter Determination but Single-Pass Encoding, EURASIP Journal on Applied Signal Processing, Jun. 2006; <http://downloads.hindawi.com/journals/asp/2006/063409.pdf>; 13 pages.
- Yegani, P. et al., "GRE Key Extension for Mobile IPv4," Network Working Group, Feb. 2006, 11 pages; <http://tools.ietf.org/pdf/draft-yegani-gre-key-extension-01.pdf>.
- Yoo, Byoung-hun, et al., "Image-Based Modeling of Urban Buildings Using Aerial Photographs and Digital Maps," Transactions in GIS, 2006, 10(3): p. 377-394.
- Zhong, Ren, et al., "Integration of Mobile IP and MPLS," Network Working Group, Jul. 2000, 15 pages; <http://tools.ietf.org/html/draft-zhong-mobile-ip-mpis-01>.
- "Oblong Industries is the developer of the g-speak spatial operation environment," Oblong Industries Information Page, 2 pages, [Retrieved and printed on Dec. 1, 2010] <http://oblong.com>.
- Underkoffler, John, "G-Speak Overview 1828121108," video clip, Video.com, 1 page, [Retrieved and printed on Dec. 1, 2010] <http://vimeo.com/2229299>.
- Kramer, Kwindla, "Mary Ann de Lares Norris at Thinking Digital," Oblong Industries, Inc. Web Log, Aug. 24, 2010; 1 page; <http://oblong.com/articles/0BS6hEeJmoHoCwgJ.html>.
- "Mary Ann de Lares Norris," video clip, Thinking Digital 2010 Day Two, May 27, 2010, 3 pages; <http://videos.thinkingdigital.co.uk/2010/05/mary-ann-de-lares-norris-oblong/>.
- Kramer, Kwindla, "Oblong at TED," Oblong Industries, Inc. Web Log, Jun. 6, 2010, 1 page; <http://oblong.com/article/0B22LFIS1NVyrOmR.html>.

- “John Underkoffler points to the future of UI,” video clip and interactive transcript; Video on TED.com, Jun. 2010, 6 pages; [http://www.ted.com/talks/john\\_underkoffler\\_drive\\_3d\\_data\\_with\\_a\\_gesture.html](http://www.ted.com/talks/john_underkoffler_drive_3d_data_with_a_gesture.html).
- Kramer, Kwindla, “Oblong on Bloomberg TV,” Oblong Industries, Inc. Web Log, Jan. 28, 2010, 1 page; [http://oblong.com/article/OAN\\_1KD9q990PEnw.html](http://oblong.com/article/OAN_1KD9q990PEnw.html).
- Kramer, Kwindla, “g-speak at RISD, Fall 2009,” Oblong Industries, Inc. Web Log, Oct. 29, 2009, 1 page; <http://oblong.com/article/09uW060q6xRIZYvm.html>.
- Kramer, Kwindla, “g-speak + TMG,” Oblong Industries, Inc. Web Log, Mar. 24, 2009, 1 page; <http://oblong.com/article/08mM77zpYMm7kFtv.html>.
- “g-stalt version 1,” video clip, YouTube.com, posted by ziggles on Mar. 15, 2009, 1 page; <http://youtube.com/watch?v=k8ZAqI4mdvk>.
- Underkoffler, John, “Carlton Sparrell speaks at MIT,” Oblong Industries, Inc. Web Log, Oct. 30, 2009, 1 page; <http://oblong.com/article/09usAB4I1Ukb6CPw.html>.
- Underkoffler, John, “Carlton Sparrell at MIT Media Lab,” video clip, Vimeo.com, 1 page, [Retrieved and printed Dec. 1, 2010] <http://vimeo.com/7355992>.
- Underkoffler, John, “Oblong at Altitude: Sundance 2009,” Oblong Industries, Inc. Web Log, Jan. 20, 2009, 1 page; [http://oblong.com/article/08Sr62ron\\_2akg0D.html](http://oblong.com/article/08Sr62ron_2akg0D.html).
- Underkoffler, John, “Oblong’s tamper system 1801011309,” video clip, Vimeo.com, 1 page, [Retrieved and printed Dec. 1, 2010] <http://vimeo.com/2821182>.
- Feld, Brad, “Science Fact,” Oblong Industries, Inc. Web Log, Nov. 13, 2008, 2 pages, <http://oblong.com/article/084H-PKISTPb9I4TI.html>.
- Kwindla Kramer, “g-speak in slices,” Oblong Industries, Inc. Web Log, Nov. 13, 2008, 6 pages; <http://oblong.com/article/0866JqfNrFg1NeuK.html>.
- Underkoffler, John, “Origins: arriving here,” Oblong Industries, Inc. Web Log, Nov. 13, 2008, 5 pages; <http://oblong.com/article/085zBpR5Y9JeLv2z.html>.
- Rishel, Christian, “Commercial overview: Platform and Products,” Oblong Industries, Inc., Nov. 13, 2008, 3 pages; <http://oblong.com/article/086E19gPvDcktA9.html>.
- “Eye Tracking,” from Wikipedia, (printed on Aug. 31, 2011) 12 pages; [http://en.wikipedia.org/wiki/Eye\\_tracker](http://en.wikipedia.org/wiki/Eye_tracker).
- “RoundTable, 360 Degrees Video Conferencing Camera unveiled by Microsoft,” TechShout, Jun. 30, 2006, 1 page; <http://www.techshout.com/gadgets/2006/30/roundtable-360-degrees-video-conferencing-camera-unveiled-by-microsoft/#>.
- Dornaika F., et al., “Head and Facial Animation Tracking Using Appearance-Adaptive Models and Particle Filters,” 20040627; 20040627-20040602, Jun. 27, 2004, 22 pages; Heudiasy Research Lab, [http://eprints.pascal-network.org/archive/00001231/01/rtvhci\\_chapter8.pdf](http://eprints.pascal-network.org/archive/00001231/01/rtvhci_chapter8.pdf).
- Eisert, Peter, “Immersive 3-D Video Conferencing: Challenges, Concepts and Implementations,” Proceedings of SPIE Visual Communications and Image Processing (VCIP), Lugano, Switzerland, Jul. 2003; 11 pages; <http://iphome.hhi.de/eisert/papers/vcip03.pdf>.
- EPO Aug. 15, 2011 Response to EPO Communication mailed Feb. 25, 2011 from European Patent Application No. 09725288.6; 15 pages.
- Geys et al., “Fast Interpolated Cameras by Combining a GPU Based Plane Sweep With a Max-Flow Regularisation Algorithm,” Sep. 9, 2004; 3D Data Processing, Visualization and Transmission 2004, pp. 534-541.
- Hammadi, Nait Charif et al., “Tracking the Activity of Participants in a Meeting,” Machine Vision and Applications, Springer, Berlin, De LnkD—DOI:10.1007/S00138-006-0015-5, vol. 17, No. 2, May 1, 2006, pp. 83-93, XP019323925 <http://citeseerx.ist.psu.edu/viewdoc/summary?doi=10.1.1.106.9832>.
- Kwolk, B., “Model Based Facial Pose Tracking Using a Particle Filter,” Geometric Modeling and Imaging—New Trends, 2006 London, England Jul. 5-6, 2005, Piscataway, NJ, USA, IEEE LNKD-DOI: 10.1109/GMA1.2006.34 Jul. 5, 2006, pp. 203-208; XP010927285.
- PCT Sep. 25, 2007 Notification of Transmittal of the International Search Report from PCT/US06/45895.
- PCT Sep. 2, 2008 International Preliminary Report on Patentability (1 page) and the Written Opinion of the ISA (4 pages) from PCT/US2006/045895.
- PCT Sep. 11, 2008 Notification of Transmittal of the International Search Report from PCT/US07/09469.
- PCT Nov. 4, 2008 International Preliminary Report on Patentability (1 page) and the Written Opinion of the ISA (8 pages) from PCT/US2007/009469.
- PCT May 11, 2010 International Search Report from PCT/US2010/024059; 4 pages.
- PCT Aug. 23, 2011 International Preliminary Report on Patentability and Written Opinion of the ISA from PCT/US2010/024059; 6 pages.
- Andreopoulos, Yiannis, et al., “In-Band Motion Compensated Temporal Filtering,” Signal Processing: Image Communication 19 (2004) 653-673, 21 pages <http://medianetlab.ee.ucla.edu/papers/011.pdf>.
- Arulampalam, M. Sanjeev, et al., “A Tutorial on Particle Filters for Online Nonlinear/Non-Gaussian Bayesian Tracking,” IEEE Transactions on Signal Processing, vol. 50, No. 2, Feb. 2002, 15 pages <http://www.cs.ubc.ca/~murphyk/Software/Kalman/ParticleFilterTutorial.pdf>.
- Garg, Ashutosh, et al., “Audio-Visual ISpeaker Detection Using Dynamic Bayesian Networks,” IEEE International Conference on Automatic Face and Gesture Recognition, 2000 Proceedings, 7 pages <http://www.ifp.illinois.edu/~ashutosh/papers/FG00.pdf>.
- Lambert, “Polycom Video Communications,” © 2004 Polycom, Inc., Jun. 20, 2004 [http://www.polycom.com/global/documents/whitepapers/video\\_communications\\_h.239\\_people\\_content\\_polycom\\_patented\\_technology.pdf](http://www.polycom.com/global/documents/whitepapers/video_communications_h.239_people_content_polycom_patented_technology.pdf).
- Liu, Shan, et al., “Bit-Depth Scalable Coding for High Dynamic Range Video,” SPIE Conference on Visual Communications and Image Processing, Jan. 2008; 12 pages <http://www.merl.com/papers/docs/TR2007-078.pdf>.
- Nakaya, Y., et al. “Motion Compensation Based on Spatial Transformations,” IEEE Transactions on Circuits and Systems for Video Technology, Jun. 1994, Abstract Only <http://ieeexplore.ieee.org/Xplore/login.jsp?url=http%3A%2F%2Fieeexplore.ieee.org%2Fiee15%2F76%2F7495%2F00305878.pdf%3Farnumber%3D305878&authDecision=-203>.
- U.S. Appl. No. 12/234,291, filed Sep. 19, 2008, entitled “System and Method for Enabling Communication Sessions in a Network Environment,” Inventors: Yifan Gao et al.
- U.S. Appl. No. 12/366,593, filed Feb. 5, 2009, entitled “System and Method for Depth Perspective Image Rendering,” Inventors: J. William Mauchly et al.
- U.S. Appl. No. 12/475,075, filed May 29, 2009, entitled “System and Method for Extending Communications Between Participants in a Conferencing Environment,” Inventors: Brian J. Baldino et al.
- U.S. Appl. No. 12/400,540, filed Mar. 9, 2009, entitled “System and Method for Providing Three Dimensional Video Conferencing in a Network Environment,” Inventors: Karthik Dakshinamoorthy et al.
- U.S. Appl. No. 12/400,582, filed Mar. 9, 2009, entitled “System and Method for Providing Three Dimensional Imaging in a Network Environment,” Inventors: Shmuel Shaffer et al.
- U.S. Appl. No. 12/539,461, filed Aug. 11, 2009, entitled “System and Method for Verifying Parameters in an Audiovisual Environment,” Inventor: James M. Alexander.
- U.S. Appl. No. 12/463,505, filed May 11, 2009, entitled “System and Method for Translating Communications Between Participants in a Conferencing Environment,” Inventors: Marthinus F. De Beer et al.
- U.S. Appl. No. 12/727,089, filed Mar. 18, 2010, entitled “System and Method for Enhancing Video Images in a Conferencing Environment,” Inventors: Joseph T. Friel.
- U.S. Appl. No. 12/781,722, filed May 17, 2010, entitled “System and Method for Providing Retracting Optics in a Video Conferencing Environment,” Inventor(s): Joseph T. Friel, et al.
- U.S. Appl. No. 12/877,833, filed Sep. 8, 2010, entitled “System and Method for Skip Coding During Video Conferencing in a Network Environment,” Inventors: Dihong Tian et al.
- U.S. Appl. No. 12/870,687, filed Aug. 27, 2010, entitled “System and Method for Producing a Performance Via Video Conferencing in a Network Environment,” Inventors: Michael A. Arnao et al.



- U.S. Appl. No. 12/912,556, filed Oct. 26, 2010, entitled "System and Method for Provisioning Flows in a Mobile Network Environment," Inventors: Balaji Vankat Vankataswami, et al.
- U.S. Appl. No. 12/949,614, filed Nov. 18, 2010, entitled "System and Method for Managing Optics in a Video Environment," Inventors: Torence Lu, et al.
- U.S. Appl. No. 12/873,100, filed Aug. 31, 2010, entitled "System and Method for Providing Depth Adaptive Video Conferencing," Inventors: J. William Mauchly et al.
- U.S. Appl. No. 12/946,679, filed Nov. 15, 2010, entitled "System and Method for Providing Camera Functions in a Video Environment," Inventors: Peter A.J. Fornell, et al.
- U.S. Appl. No. 12/946,695, filed Nov. 15, 2010, entitled "System and Method for Providing Enhanced Audio in a Video Environment," Inventors: Wei Li, et al.
- U.S. Appl. No. 12/907,914, filed Oct. 19, 2010, entitled "System and Method for Providing Videomail in a Network Environment," Inventors: David J. Mackie et al.
- U.S. Appl. No. 12/907,919, filed Oct. 19, 2010, entitled "System and Method for Providing Connectivity in a Network Environment," Inventors: David J. Mackie et al.
- U.S. Appl. No. 12/946,704, filed Nov. 15, 2010, entitled "System and Method for Providing Enhanced Graphics in a Video Environment," Inventors: John M. Kanalakis, Jr., et al.
- U.S. Appl. No. 12/957,116, filed Nov. 30, 2010, entitled "System and Method for Gesture Interface Control," Inventors: Shuan K. Kirby, et al.
- U.S. Appl. No. 12/907,925, filed Oct. 19, 2010, entitled "System and Method for Providing a Pairing Mechanism in a Video Environment," Inventors: Gangfeng Kong et al.
- U.S. Appl. No. 12/939,037, filed Nov. 3, 2010, entitled "System and Method for Managing Flows in a Mobile Network Environment," Inventors: Balaji Venkat Venkataswami et al.
- U.S. Appl. No. 12/946,709, filed Nov. 15, 2010, entitled "System and Method for Providing Enhanced Graphics in a Video Environment," Inventors: John M. Kanalakis, Jr., et al.
- U.S. Appl. No. 12/784,257, filed May 20, 2010, entitled "Implementing Selective Image Enhancement," Inventors: Dihong Tian et al.
- U.S. Appl. No. 29/375,624, filed Sep. 24, 2010, entitled "Mounted Video Unit," Inventor(s): Ashok T. Desai et al.
- U.S. Appl. No. 29/375,627, filed Sep. 24, 2010, entitled "Mounted Video Unit," Inventor(s): Ashok T. Desai et al.
- U.S. Appl. No. 29/369,951, filed Sep. 15, 2010, entitled "Video Unit With Integrated Features," Inventor(s): Kyle A. Buzzard et al.
- U.S. Appl. No. 29/375,458, filed Sep. 22, 2010, entitled "Video Unit With Integrated Features," Inventor(s): Kyle A. Buzzard et al.
- U.S. Appl. No. 29/358,009, filed Mar. 21, 2010, entitled "Free-Standing Video Unit," Inventor(s): Ashok T. Desai et al.
- U.S. Appl. No. 29/375,619, filed Sep. 24, 2010, entitled "Free-Standing Video Unit," Inventor(s): Ashok T. Desai et al.
- PCT "International Search Report and the Written Opinion of the International Searching Authority, or the Declaration," PCT/US2010/026456, dated Jun. 29, 2010; 11 pages.
- PCT "Notification of Transmittal of the International Search Report and the Written Opinion of the International Searching Authority, or the Declaration," PCT/US2009/001070, dated Apr. 4, 2009; 14 pages.
- PCT "Notification of Transmittal of the International Search Report and the Written Opinion of the International Searching Authority, or the Declaration," PCT/US2009/038310; dated Oct. 10, 2009; 17 pages.
- PCT "International Preliminary Report on Patentability and Written Opinion of the International Searching Authority," PCT/US2009/038310; dated Sep. 28, 2010; 10 pages.
- PCT "International Preliminary Report on Patentability dated Sep. 29, 2009, International Search Report, and Written Opinion," for PCT International Application PCT/US2008/058079; dated Sep. 18, 2008, 10 pages.
- "3D Particles Experiments in AS3 and Flash CS3," [retrieved and printed on Mar. 18, 2010]; 2 pages; <http://www.flashandmath.com/advanced/fourparticles/notes.html>.
- 3G, "World's First 3G Video Conference Service with New TV Commercial," Apr. 28, 2005, 4 pages; <http://www.3g.co.uk/PR/April2005/1383.htm>.
- Digital Video Enterprises, "DVE Eye Contact Silhouette," 1 page, © DVE 2008; <http://www.dvetelepresence.com/products/eyeContactSilhouette.asp>.
- France Telecom R&D, "France Telecom's Magic Telepresence Wall—Human Productivity Lab," 5 pages, retrieved and printed on May 17, 2010; [http://www.humanproductivitylab.com/archive\\_blogs/2006/07/11/france\\_telecoms\\_magic\\_telepres\\_1.php](http://www.humanproductivitylab.com/archive_blogs/2006/07/11/france_telecoms_magic_telepres_1.php).
- Joshua Gluckman and S.K. Nayar, "Rectified Catadioptric Stereo Sensors," 8 pages, retrieved and printed on May 17, 2010; <http://cis.poly.edu/~gluckman/papers/cvpr00.pdf>.
- R.V. Kollarits, et al., "34.3: An Eye Contact Camera/Display System for Videophone Applications Using a Conventional Direct-View LCD," © 1995 SID, ISSN0097-0966X/95/2601, pp. 765-768; <http://citeseerx.ist.psu.edu/viewdoc/download;jsessionid=47A1E7e028C26503975E633895D114EC?doi=10.1.1.42.1772&rep=rep1&type=pdf>.
- Trevor Darrell, "A Real-Time Virtual Mirror Display," 1 page, Sep. 9, 1998; <http://people.csail.mit.edu/trevor/papers/1998-021/node6.html>.
- Video on TED.com, Pranav Mistry: the Thrilling Potential of SixthSense Technology (5 pages) and Interactive Transcript (5 pages), retrieved and printed on Nov. 30, 2010; [http://www.ted.com/talks/pranav\\_mistry\\_the\\_thrilling\\_potential\\_of\\_sixthsense\\_technology.html](http://www.ted.com/talks/pranav_mistry_the_thrilling_potential_of_sixthsense_technology.html).
- PCT Sep. 13, 2011 International Preliminary Report on Patentability and the Written Opinion of the ISA from PCT/US2010/026456; 5 pages.
- PCT Oct. 12, 2011 International Search Report and Written Opinion of the ISA from PCT/US2011/050380.
- Patterson, E.K., et al., "Moving-Talker, Speaker-Independent Feature Study and Baseline Results Using the CUAVE Multimodal Speech Corpus," EURASIP Journal on Applied Signal Processing, vol. 11, Oct. 2002, 15 pages [http://www.clemson.edu/ces/speech/papers/CUAVE\\_Eurasip2002.pdf](http://www.clemson.edu/ces/speech/papers/CUAVE_Eurasip2002.pdf).
- Perez, Patrick, et al., "Data Fusion for Visual Tracking with Particles," Proceedings of the IEEE, vol. XX, No. XX, Feb. 2004, 18 pages <http://citeseer.ist.psu.edu/viewdoc/summary?doi=10.1.1.6.2480>.
- Potamianos, G., et al., "An Image Transform Approach for HMM Based Automatic Lipreading," in Proceedings of IEEE ICIP, vol. 3, 1998, 5 pages <http://citeseerx.ist.psu.edu/viewdoc/summary?doi=10.1.1.13.6802>.
- Rikert, T.D., et al., "Gaze Estimation using Morphable models," IEEE International Conference on Automatic Face and Gesture Recognition, Apr. 1998; 7 pgs <http://citeseerist.psu.edu/viewdoc/summary?doi=10.1.1.30.9472>.
- Tan, Kar-Han, et al., "Appearance-Based Eye Gaze Estimation," in Proceedings IEEE WACV'02, 2002, 5 pages <http://citeseerist.psu.edu/viewdoc/summary?doi=10.1.1.19.8921>.
- Vertegaal, Roel, et al., "Gaze-2: Conveying Eye Contact in Group Video Conferencing Using Eye-Controlled Camera Direction," CHI 2003, Apr. 5-10, 2003, Fort Lauderdale, FL; Copyright 2003 ACM 1-58113-630-7/03/0004; 8 pages; <http://www.hml.queensu.ca/papers/vertegaalchi0403.pdf>.
- Weinstein et al., "Emerging Technologies for Teleconferencing and Telepresence," Wainhouse Research 2005 <http://www.ivci.com/pdf/whitepaper-emerging-technologies-for-teleconferencing-and-telepresence.pdf>.
- EPO Nov. 3, 2011 Communication from European Application EP10710949.8; 2 pages.
- EPO Mar. 12, 2012 Response to EP Communication dated Nov. 2, 2011 from European Application EP10710949.8; 15 pages.
- EPO Mar. 20, 2012 Communication from European Application 09725288.6; 6 pages.
- U.S. Appl. No. 13/298,022, filed Nov. 16, 2011, entitled "System and Method for Alerting a Participant in a Video Conference," Inventor(s): TiongHu Lian, et al.
- "Eye Gaze Response Interface Computer Aid (Erica) tracks Eye movement to enable hands-free computer operation," UMD Communication Sciences and Disorders Tests New Technology, University

of Minnesota Duluth, posted Jan. 19, 2005; 4 pages <http://www.d.umn.edu/unirel/homepage/05/eyegaze.html>.

Gvili, Ronen et al., "Depth Keying," 3DV System Ltd., [Retrieved and printed on Dec. 5, 2011] 11 pages; <http://research.microsoft.com/en-us/um/people/eyalofek/Depth%20Key/DepthKey.pdf>.

PCT Nov. 24, 2011 International Preliminary Report on Patentability from International Application Serial No. PCT/US2010/033880; 6 pages.

U.S. Appl. No. 13/036,925, filed Feb. 28, 2011, entitled "System and Method for Selection of Video Data in a Video Conference Environment," Inventor(s) Sylvia Olayinka Aya Manfa N'guessan.

Gussenhoven, Carlos, "Chapter 5: Transcription of Dutch Intonation," 33 pages, Nov. 9, 2003; <http://www.ru.nl/publish/pages/516003/todisun-ah.pdf>.

Hock, Hans Henrich, "Prosody vs. Syntax: Prosodic rebracketing of final vocatives in English," 4 pages; [retrieved and printed on Mar. 3, 2011] <http://speechprosody2010.illinois.edu/papers/100931.pdf>.

"Vocative Case," from Wikipedia, [retrieved and printed on Mar. 3, 2011] 11 pages; [http://en.wikipedia.org/wiki/Vocative\\_case](http://en.wikipedia.org/wiki/Vocative_case).

PCT Jan. 23, 2012 International Search Report and Written Opinion of the ISA from International Application Serial No. PCT/US2011/060579; 10 pages.

PCT Jan. 23, 2012 International Search Report and Written Opinion of the ISA from International Application Serial No. PCT/US2011/060584; 11 pages.

PCT Feb. 20, 2012 International Search Report and Written Opinion of the ISA from International Application Serial No. PCT/US2011/061442; 12 pages.

\* cited by examiner

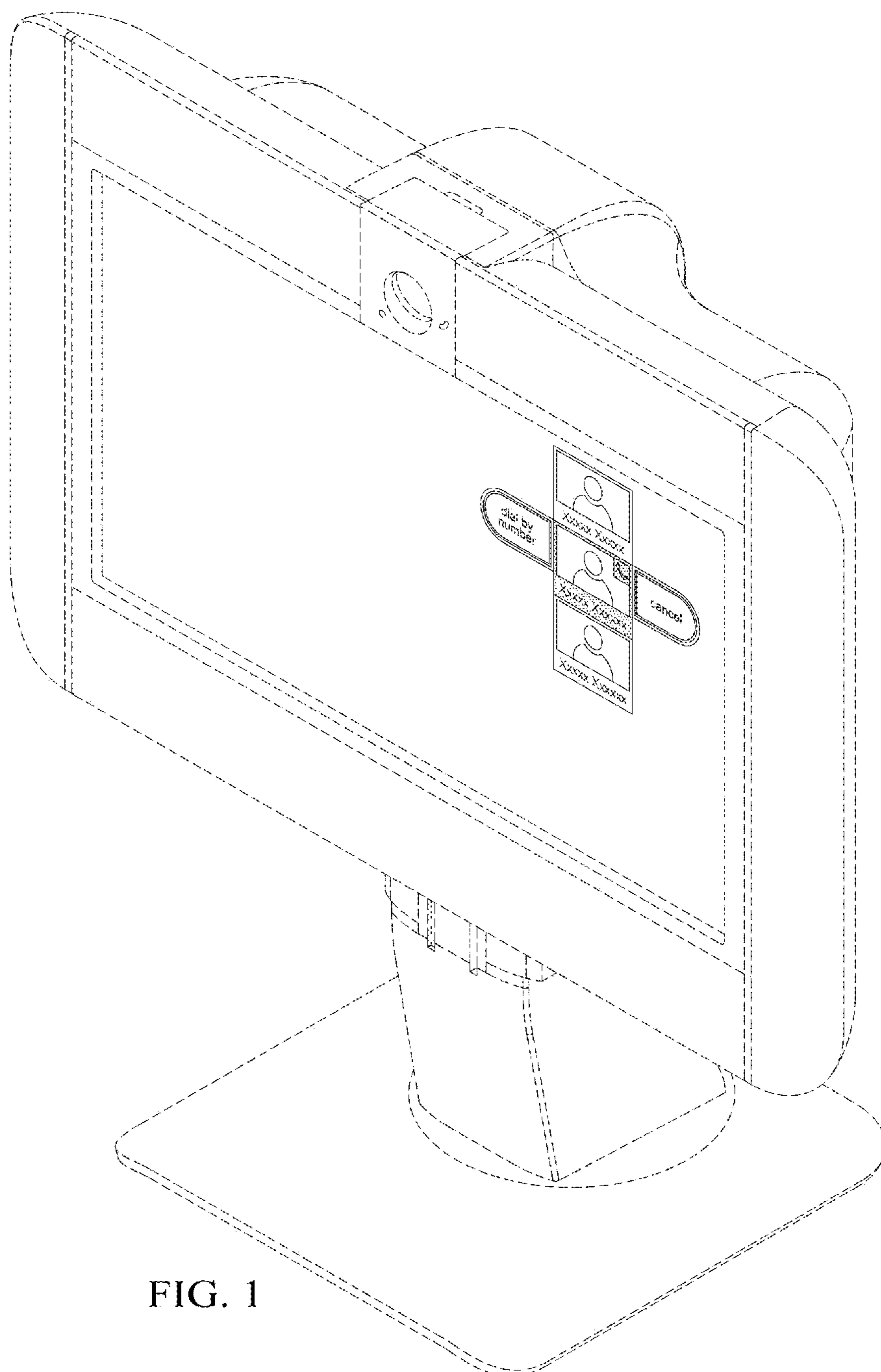

FIG. 1

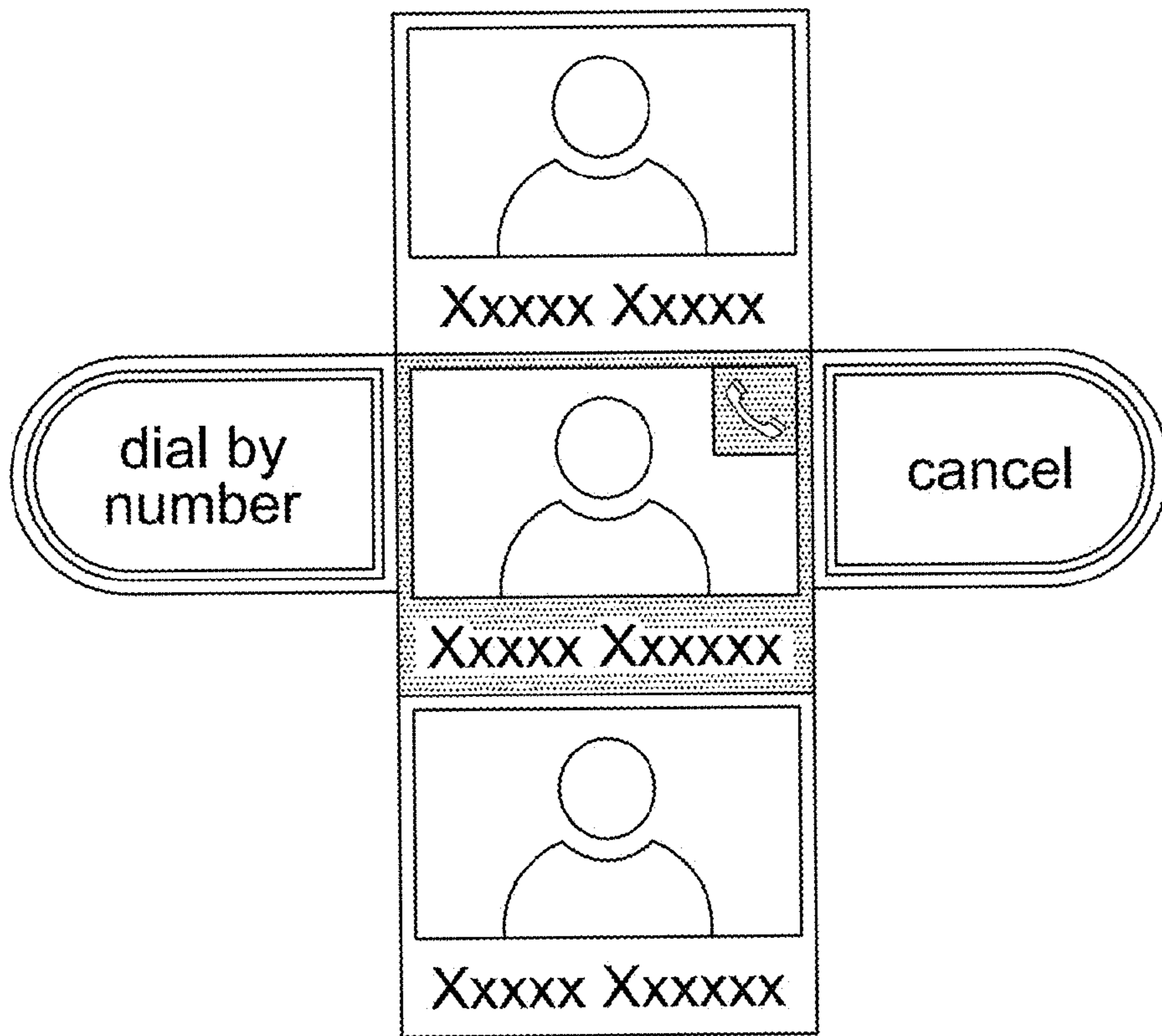

FIG. 2