



US00D678092S

(12) **United States Design Patent**
Tan et al.

(10) **Patent No.:** **US D678,092 S**
(45) **Date of Patent:** **** Mar. 19, 2013**

(54) **MULTIMETER**

(75) Inventors: **Po-Chao Tan**, New Taipei (TW);
Chin-An Chou, New Taipei (TW)

(73) Assignee: **Brymen Technology Corporation**, New Taipei (TW)

(**) Term: **14 Years**

(21) Appl. No.: **29/405,744**

(22) Filed: **Nov. 4, 2011**

(51) **LOC (9) Cl.** **10-04**

(52) **U.S. Cl.** **D10/78**

(58) **Field of Classification Search** D10/78;
324/66, 67, 158 P, 539–542, 72.5, 556, 133,
324/149, 503, 543, 555, 72, 754, 115, 141,
324/114, 145, 156, 508; 379/21, 60, 66,
379/96, 106.01–106.11; 340/635, 687, 654;
73/866.5

See application file for complete search history.

(56) **References Cited**

U.S. PATENT DOCUMENTS

D474,704	S	*	5/2003	Ikeda et al.	D10/79
D512,333	S	*	12/2005	Blacken et al.	D10/78
D514,005	S	*	1/2006	Gregorec et al.	D10/79
D545,704	S	*	7/2007	Kuramoto	D10/79
D567,687	S	*	4/2008	Elrod	D10/79
D585,316	S	*	1/2009	Chang	D10/79
7,750,621	B1	*	7/2010	Liu	324/126
D625,633	S	*	10/2010	Laurino et al.	D10/78
7,944,197	B2	*	5/2011	Shah et al.	324/115
D640,152	S	*	6/2011	Laurino et al.	D10/79
D642,945	S	*	8/2011	Marzynski et al.	D10/79
8,330,449	B2	*	12/2012	Greenberg	324/127

* cited by examiner

Primary Examiner — Antoine D Davis

(74) *Attorney, Agent, or Firm* — Chun-Ming Shih; HDLS IPR Services

(57) **CLAIM**

The ornamental design for a multimeter, as shown and described.

DESCRIPTION

FIG. 1 is a perspective view of a multimeter showing my new design;

FIG. 2 is a front view thereof;

FIG. 3 is a rear view thereof;

FIG. 4 is a left side view thereof;

FIG. 5 is a right side view thereof;

FIG. 6 is a top view thereof;

FIG. 7 is a bottom view thereof.

FIG. 8 is another perspective view showing the multimeter.

FIG. 9 is a perspective view of a multimeter according to a second preferred embodiment.

FIG. 10 is a perspective view of a multimeter according to a third preferred embodiment.

FIG. 11 is a perspective view of a multimeter according to a fourth preferred embodiment.

FIG. 12 is a perspective view of a multimeter according to a fifth preferred embodiment.

FIG. 13 is a perspective view of a multimeter according to a sixth preferred embodiment.

FIG. 14 is a perspective view of a multimeter according to a seventh preferred embodiment.

FIG. 15 is a perspective view of the multimeter having a hook installed thereon; and,

FIG. 16 is a perspective view of the multimeter having another hook installed thereon.

The broken line environmental showing is for illustrative purpose only and forms no part of the claimed design.

1 Claim, 15 Drawing Sheets

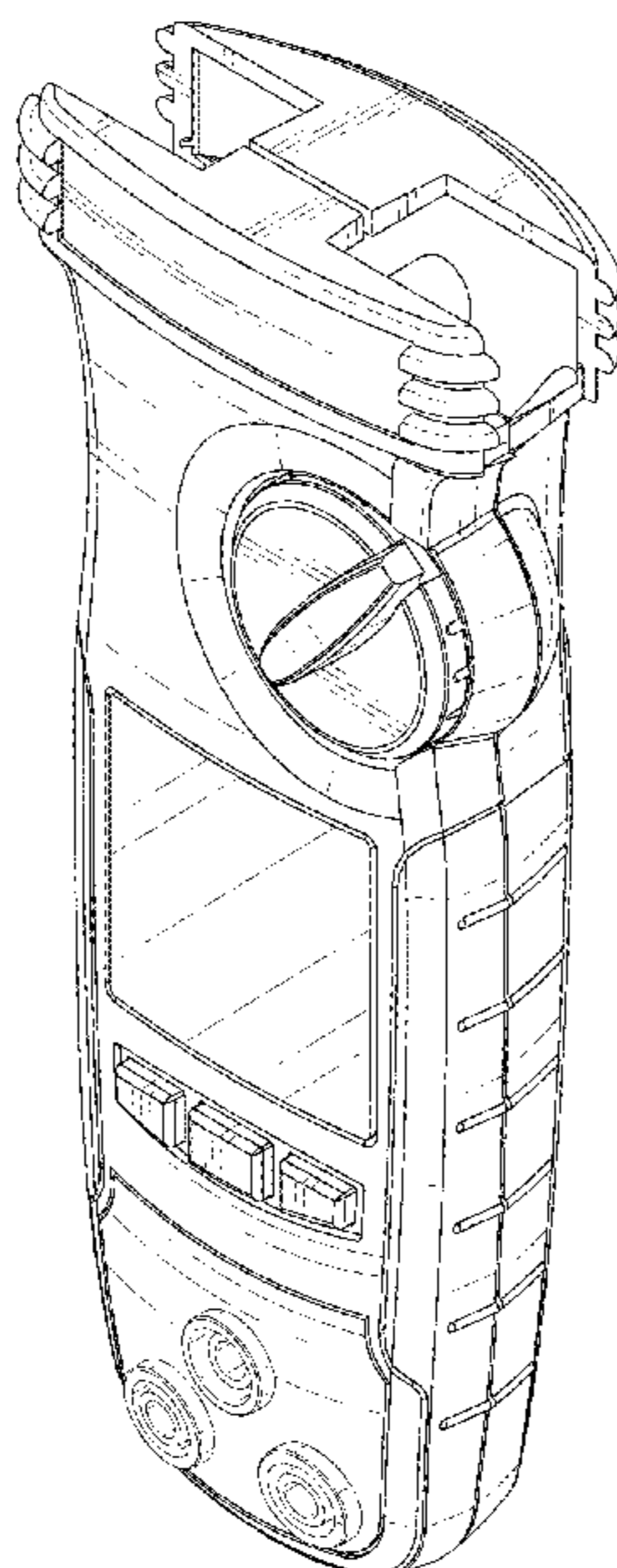

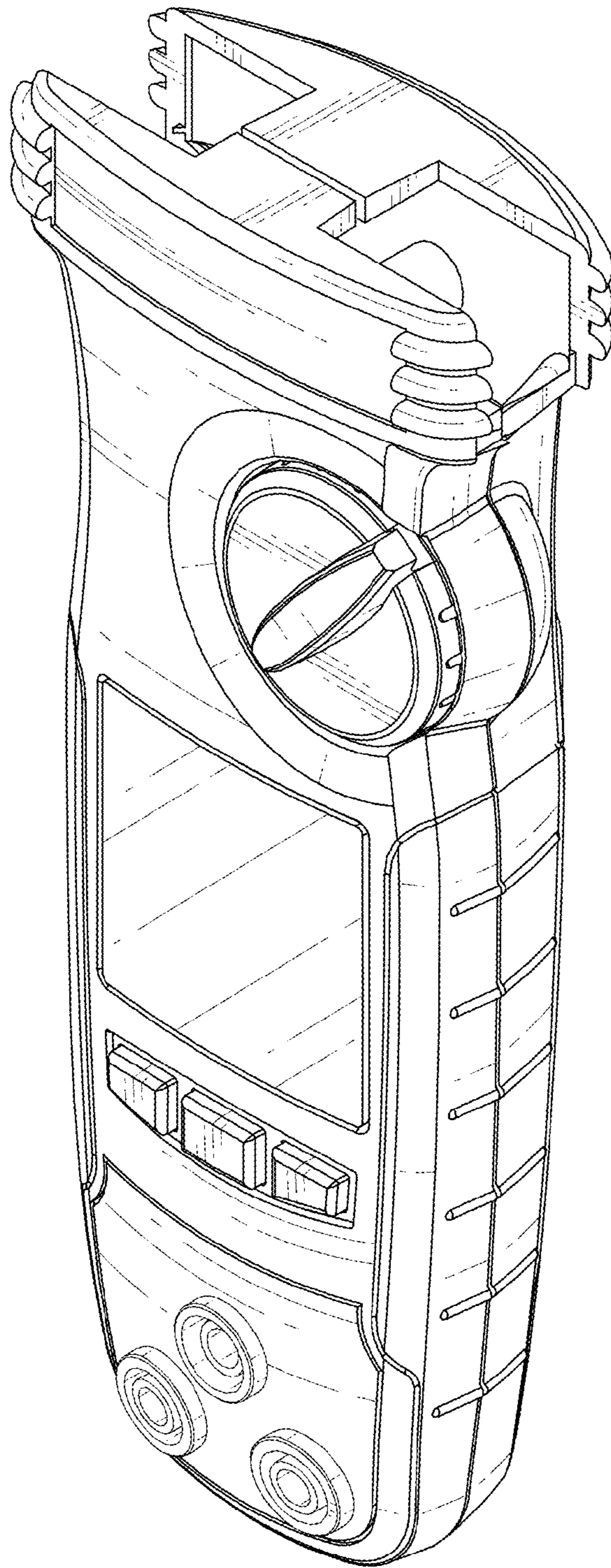

FIG.1

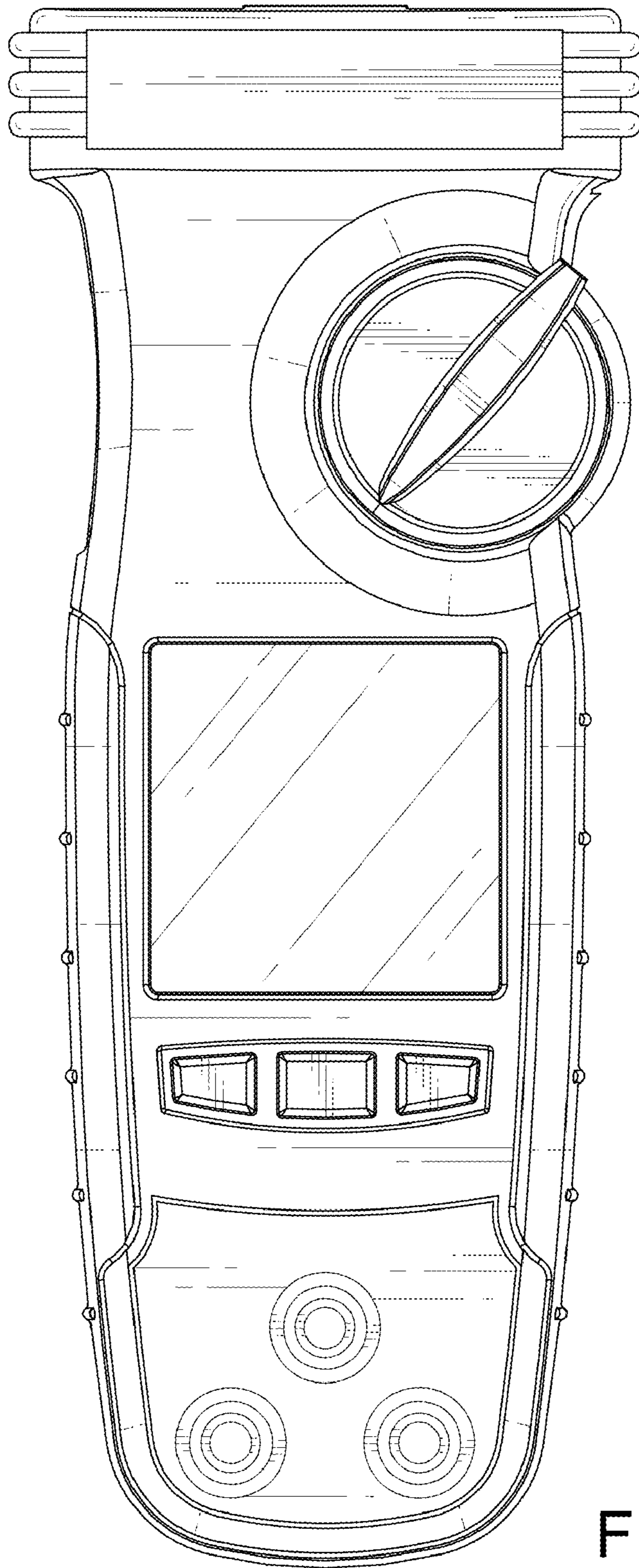

FIG.2

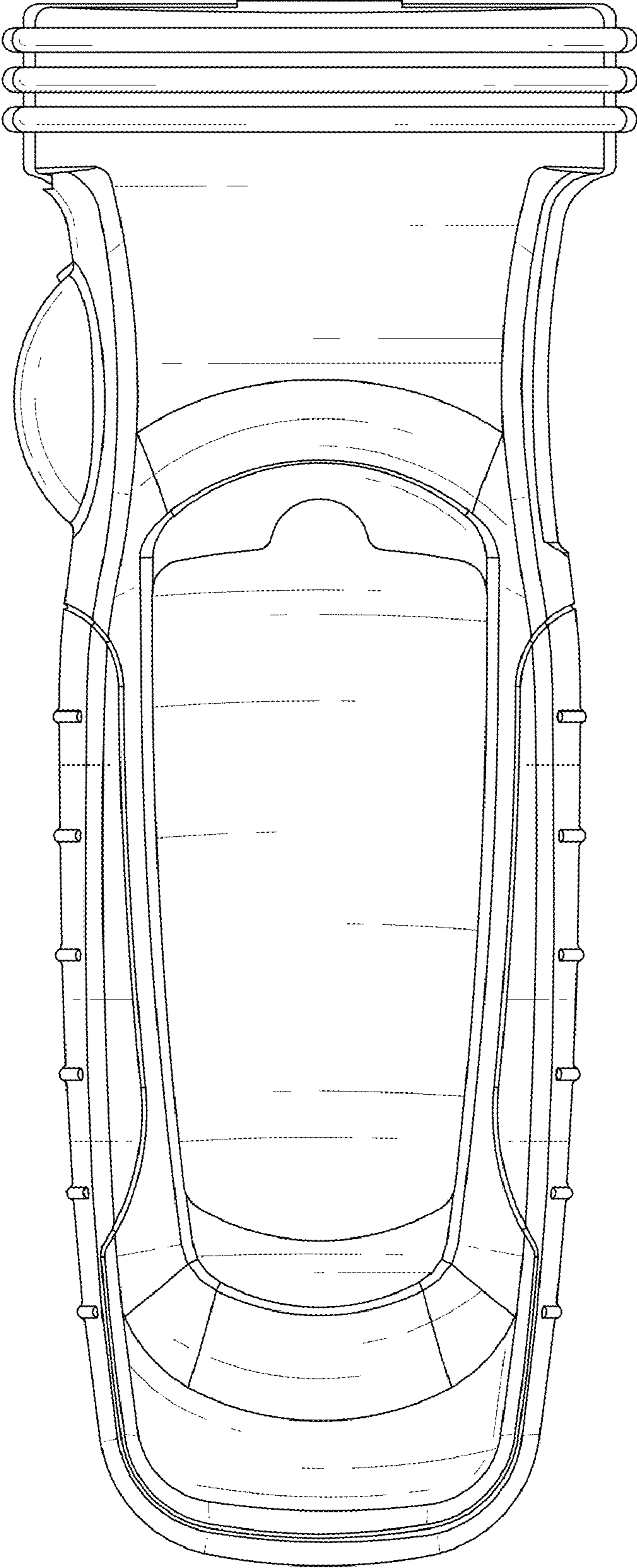

FIG.3

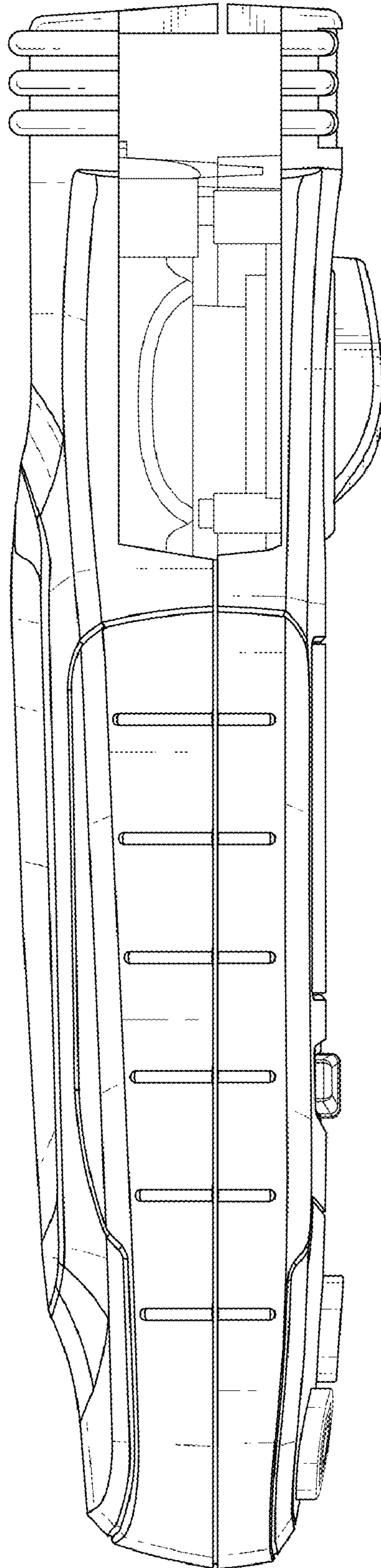

FIG.4

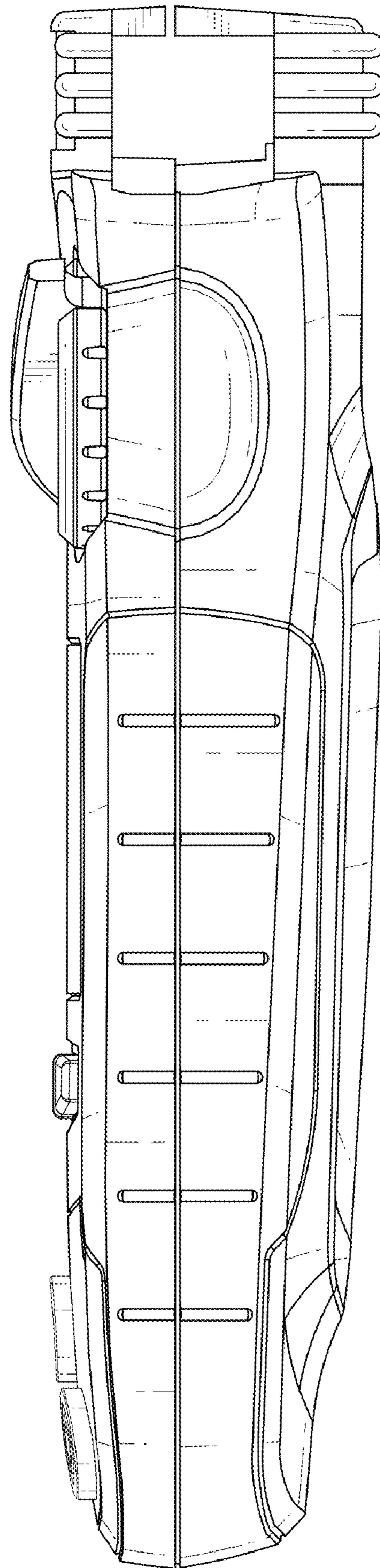

FIG.5

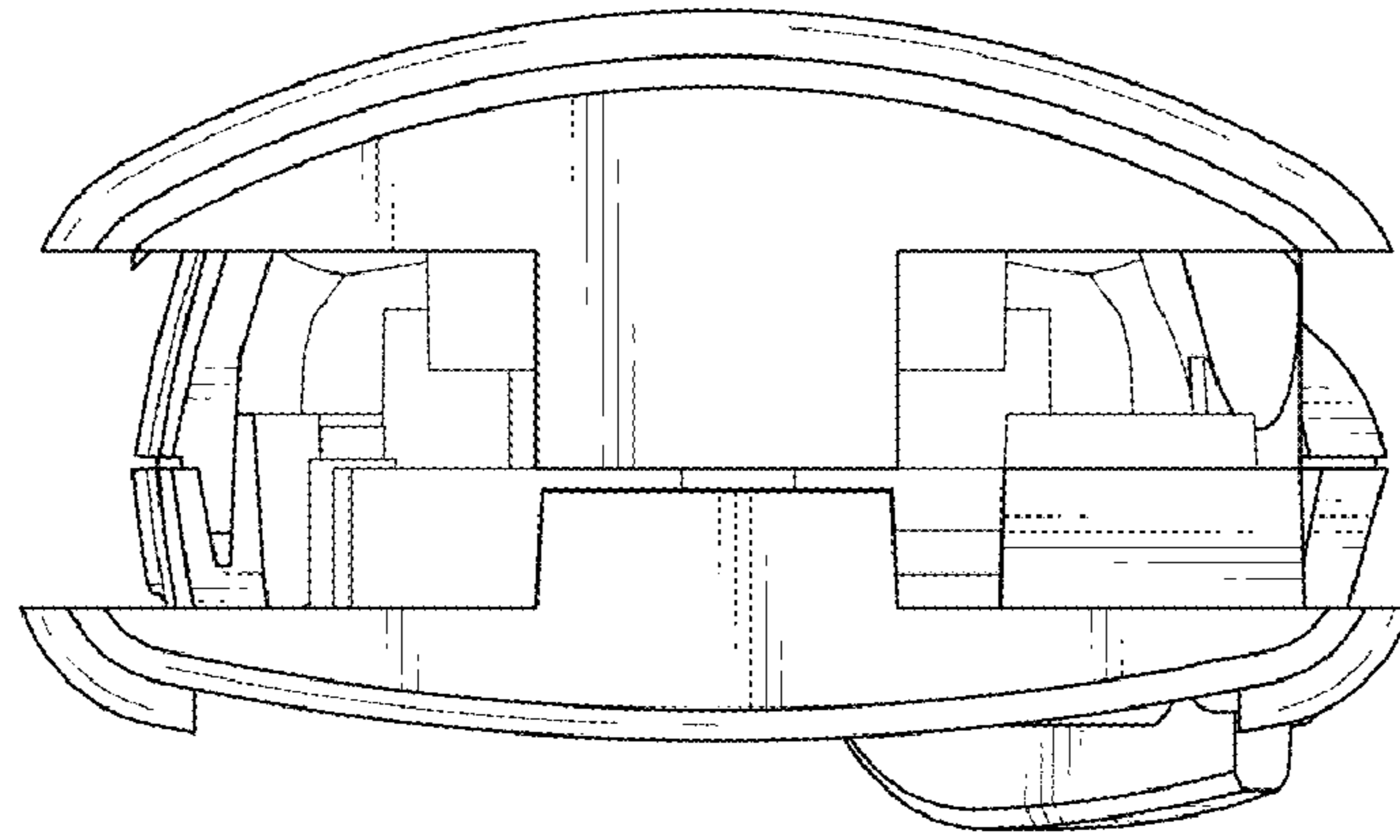

FIG. 6

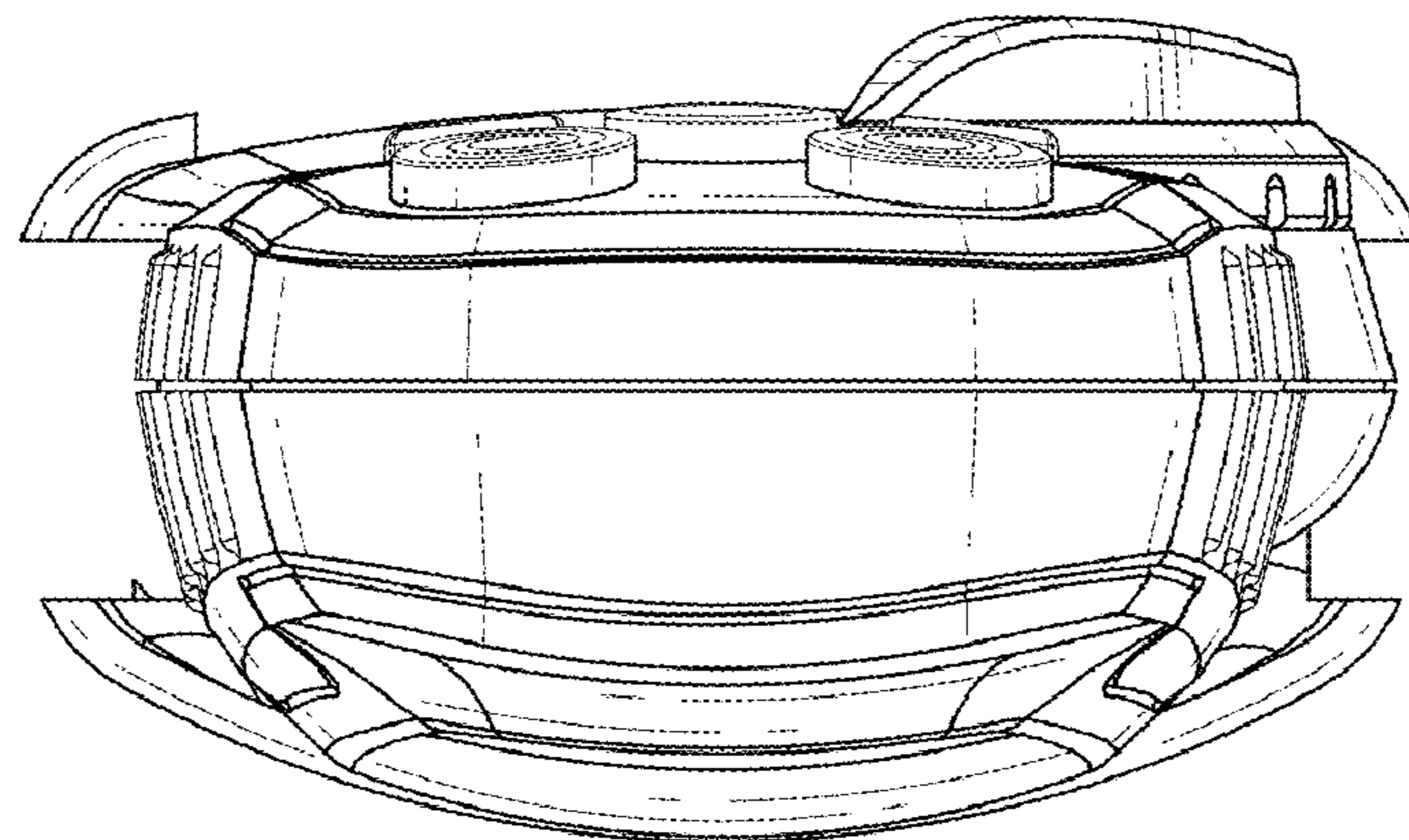

FIG. 7

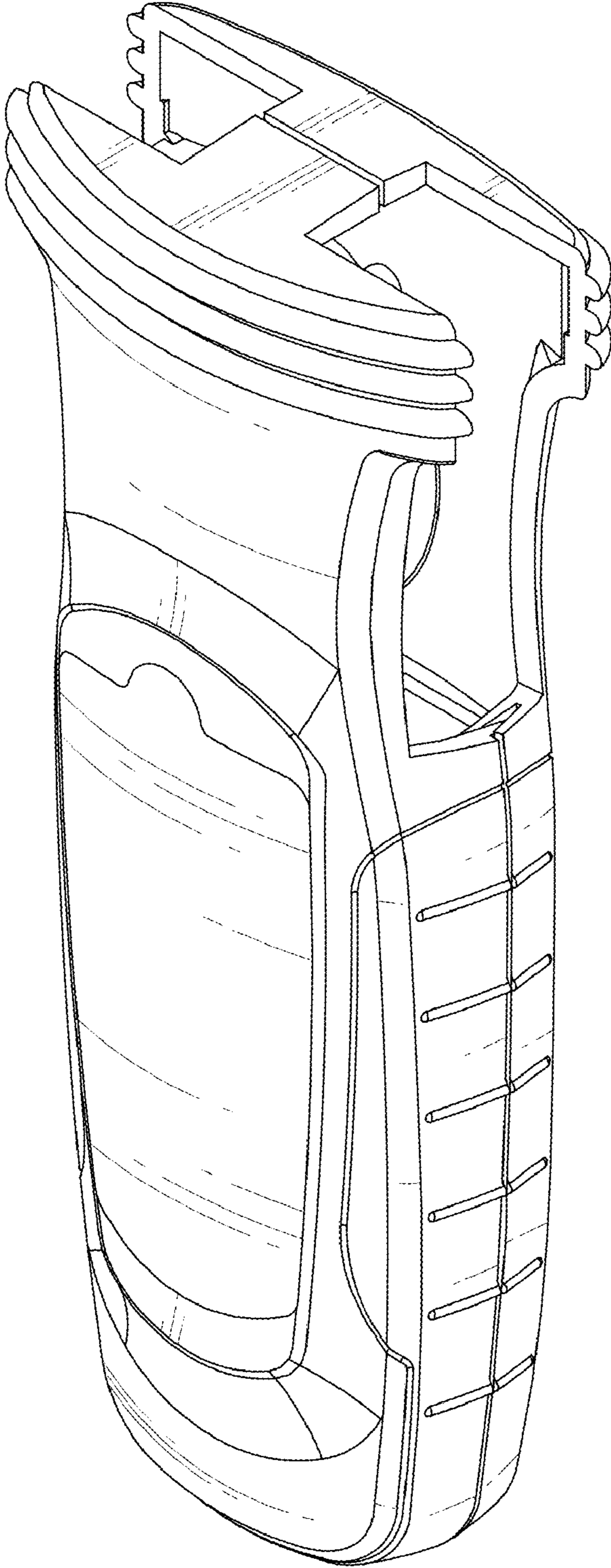

FIG.8

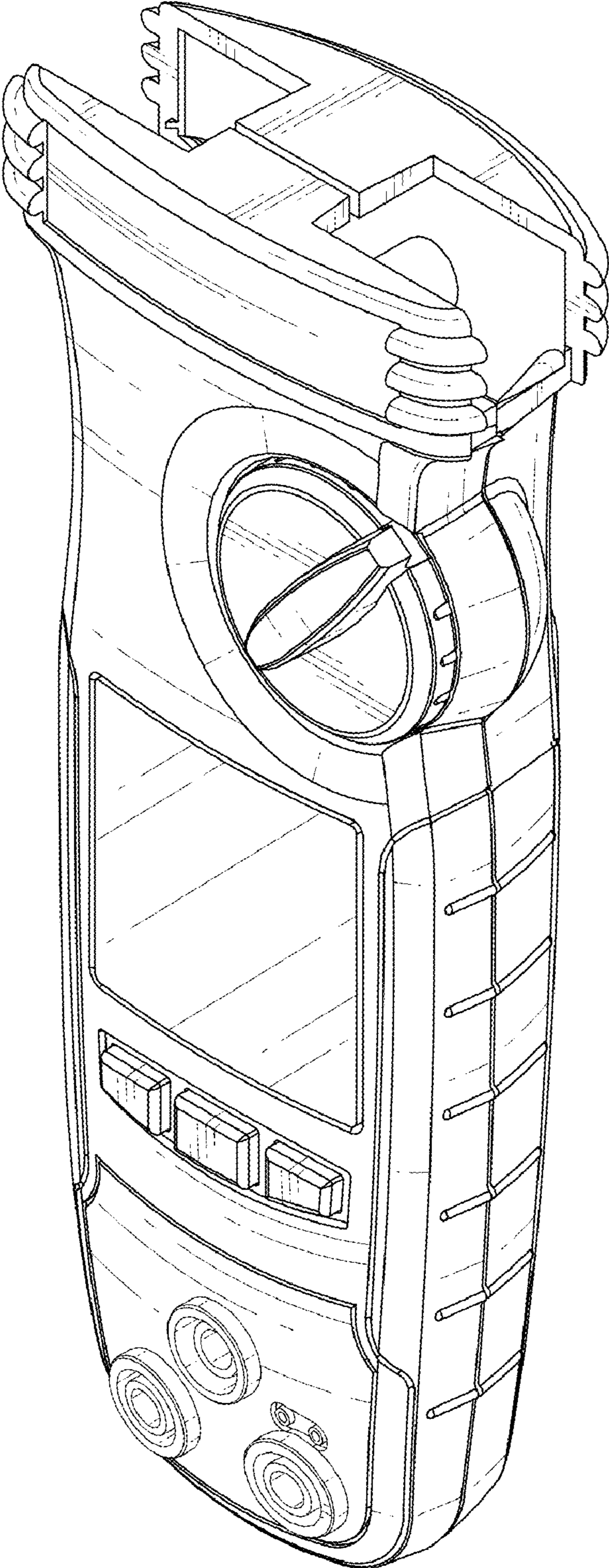

FIG.9

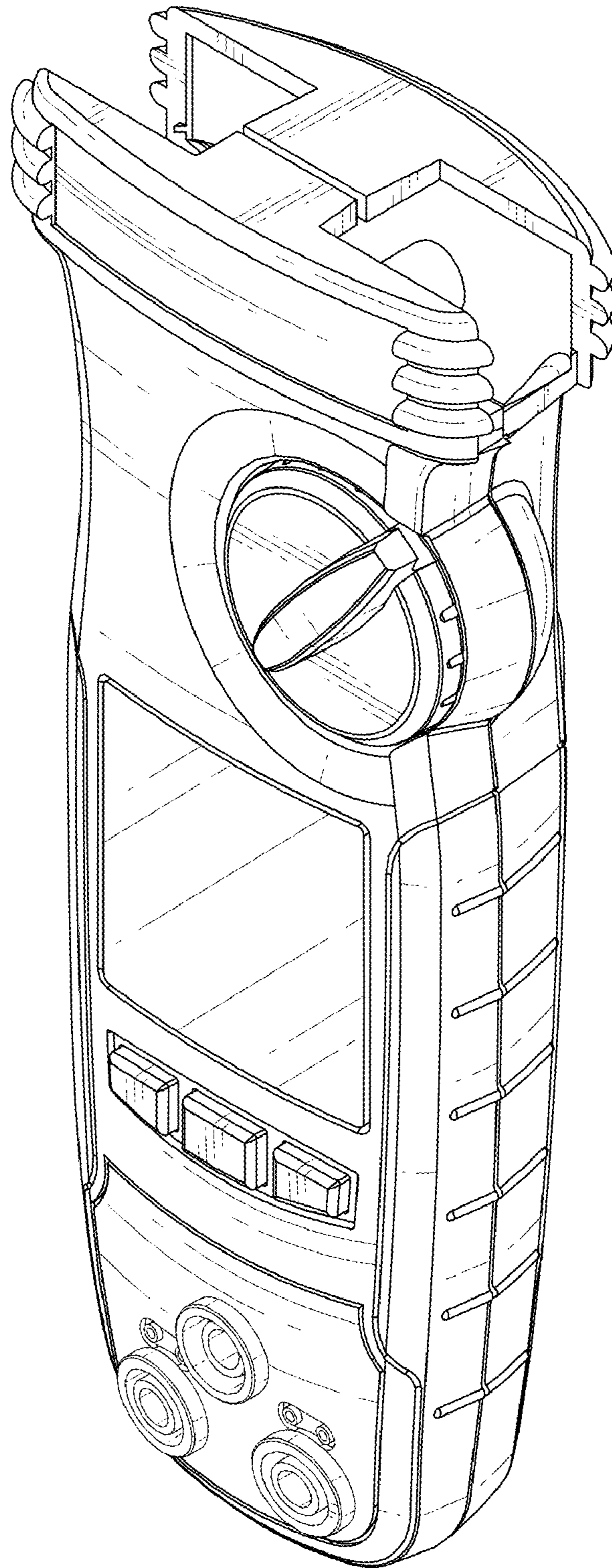

FIG. 10

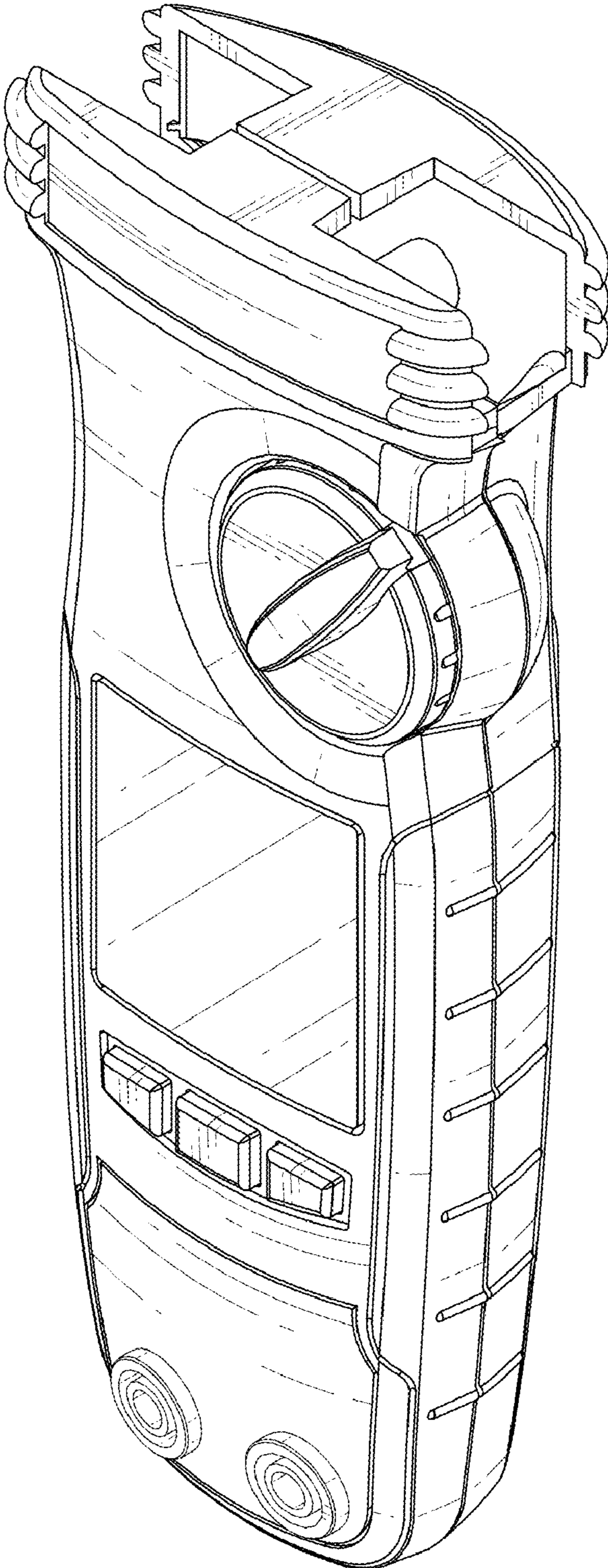

FIG.11

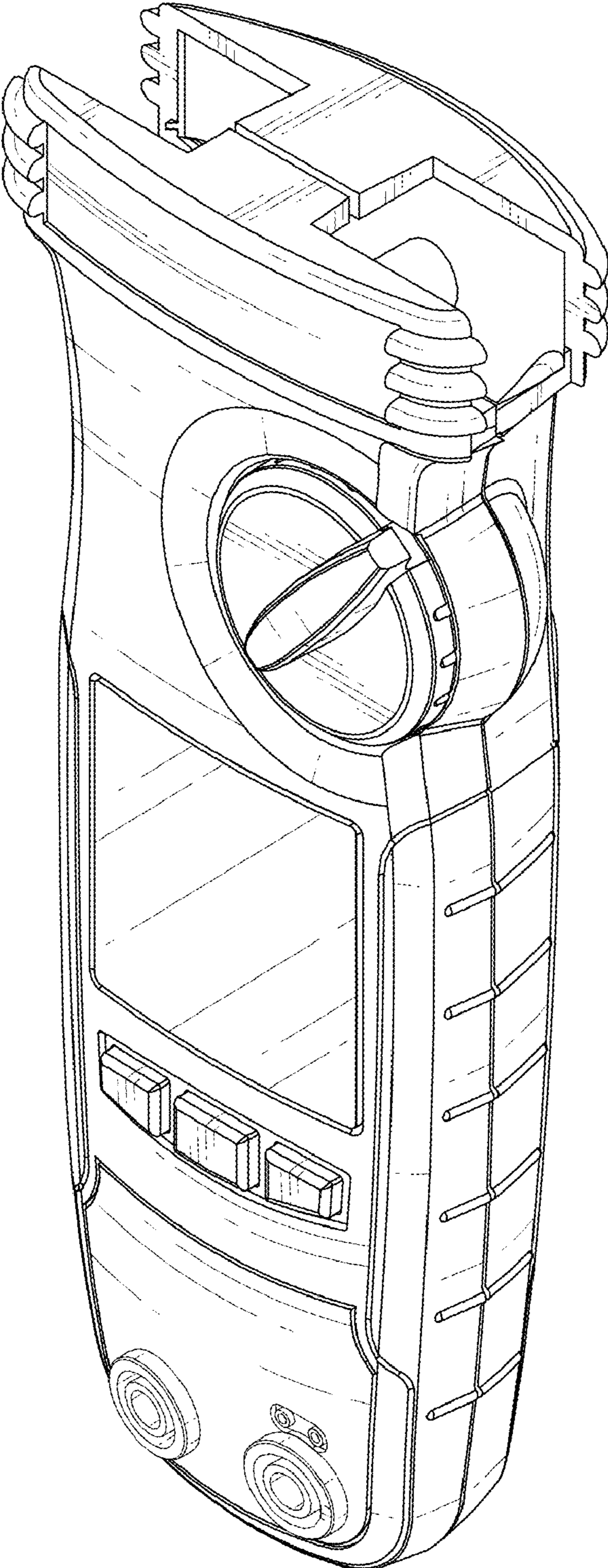

FIG.12

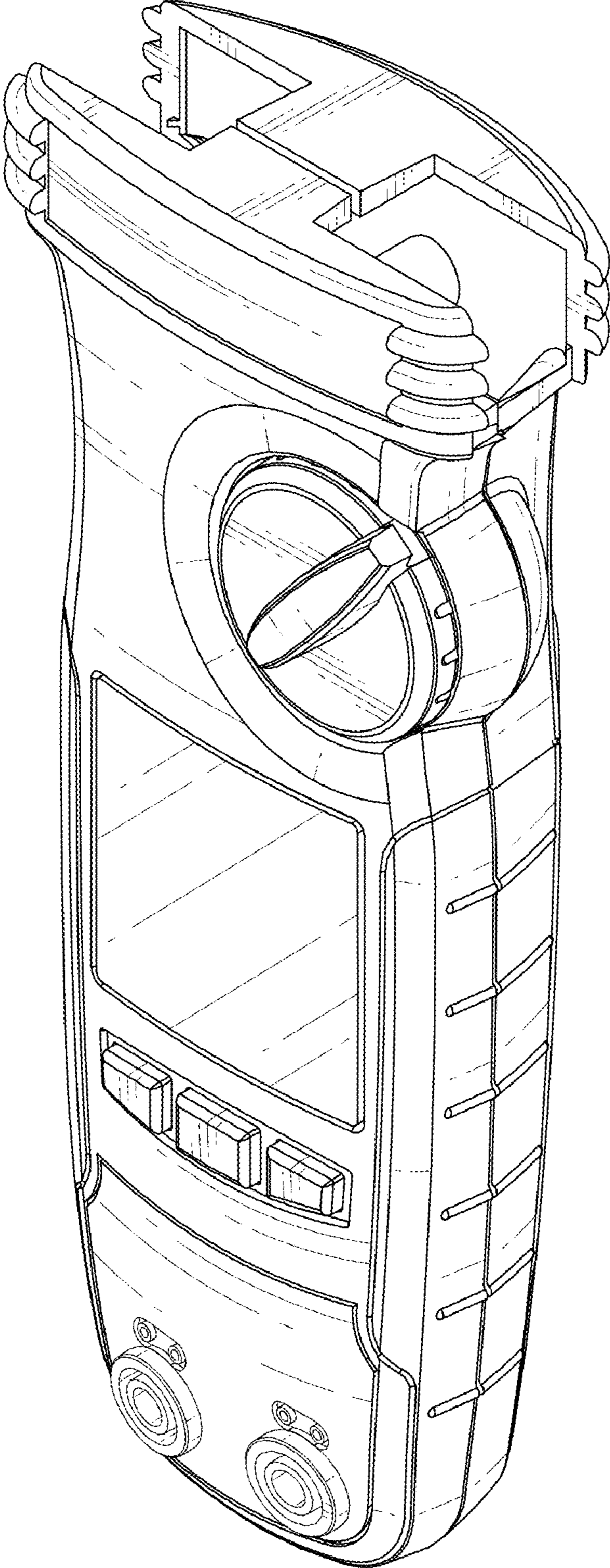

FIG.13

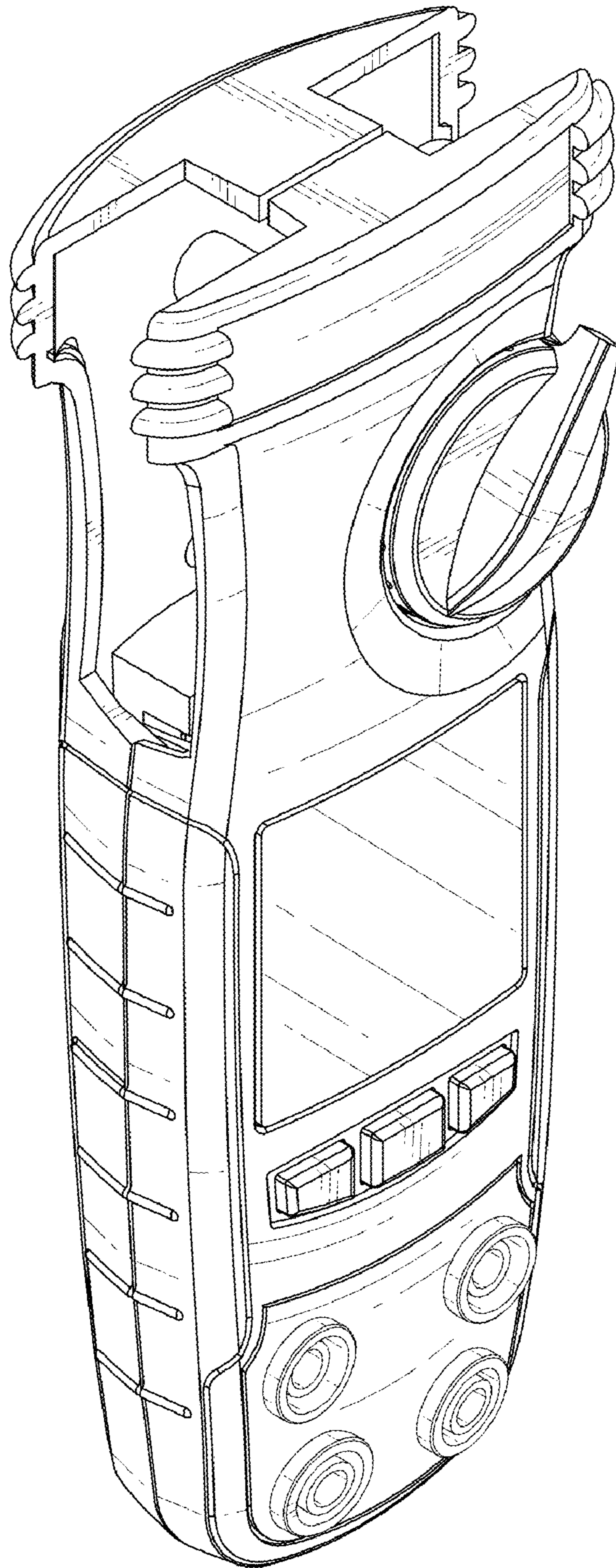

FIG.14

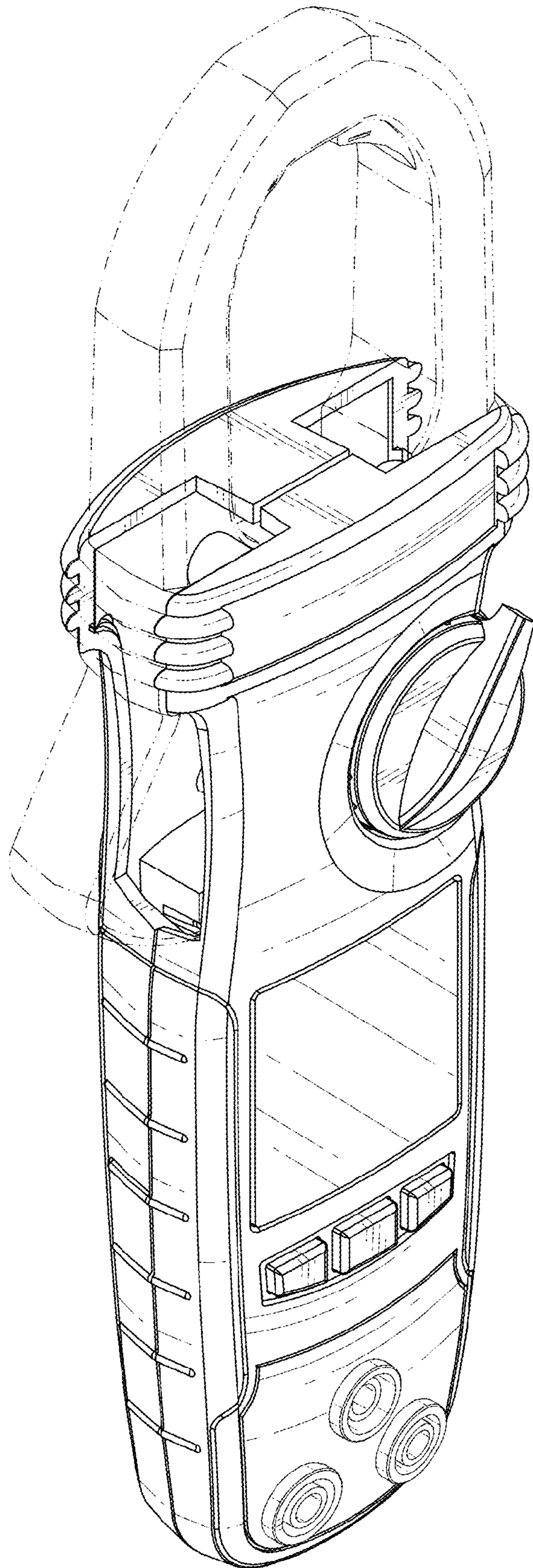

FIG. 15

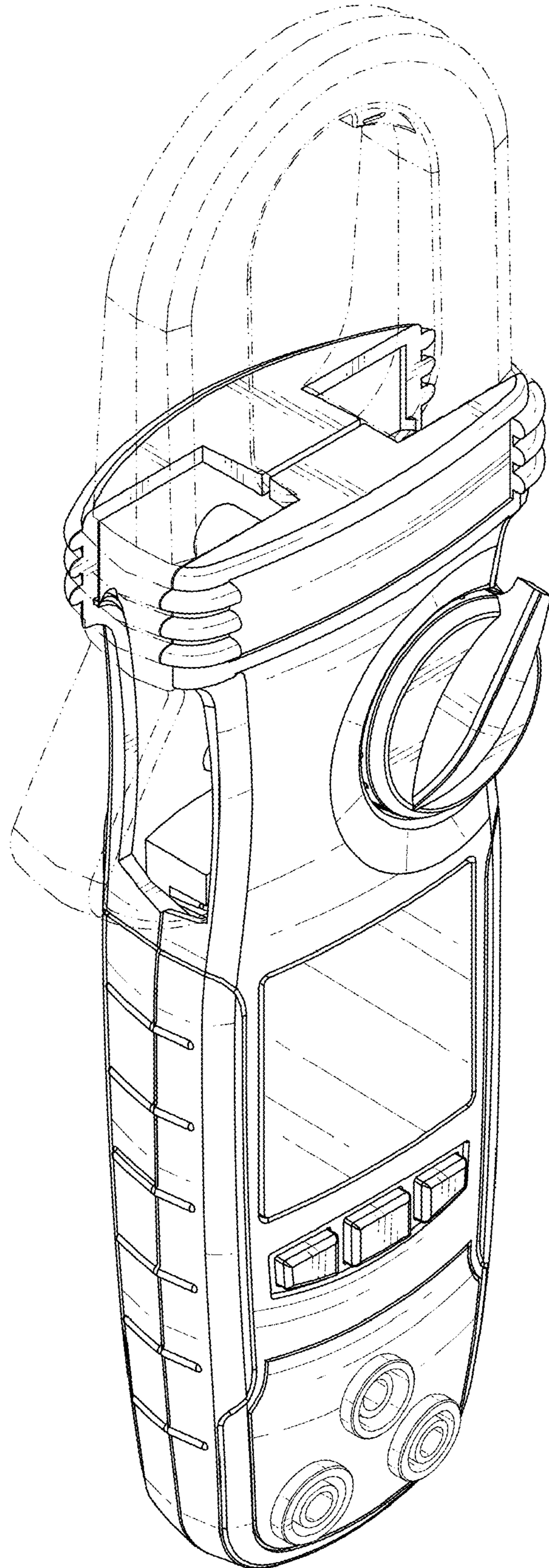

FIG.16