



US00D678083S

(12) **United States Design Patent**  
**Breuer et al.**

(10) **Patent No.:** **US D678,083 S**  
(45) **Date of Patent:** **\*\* Mar. 19, 2013**

(54) **ENCLOSURE FOR SENSORS AND TRANSMITTERS FOR HVAC/R APPLICATIONS**

publication: Nov. 1997; Publisher: Mescon Technologies, Inc.; Where published: Frankfort, IL, USA; 2 pages.

(Continued)

(75) Inventors: **Walter P. Breuer**, Westby, WI (US);  
**Alexander P. Ingram**, Blue River, WI (US);  
**Nicholas W. Hauk**, Cassville, WI (US)

*Primary Examiner* — Antoine D Davis  
(74) *Attorney, Agent, or Firm* — Boardman & Clark LLP;  
Joseph W. Bryne

(73) Assignee: **Building Automation Products, Inc.**,  
Gays Mills, WI (US)

(57) **CLAIM**  
The ornamental design for an enclosure for sensors and transmitters for HVAC/R applications, as shown and described.

**DESCRIPTION**

(\*\*) Term: **14 Years**  
(21) Appl. No.: **29/371,787**  
(22) Filed: **Sep. 23, 2011**

FIG. 1 is a top, front and right side perspective view of an enclosure for sensors and transmitters for HVAC/R applications in accordance with our new design;  
FIG. 2 is a top, front and left side perspective view of the enclosure shown in FIG. 1;  
FIG. 3 is a front elevation view of the enclosure shown in FIG. 1;  
FIG. 4 is a right side elevation view of the enclosure shown in FIG. 1;  
FIG. 5 is a left side elevation view of the enclosure shown in FIG. 1;  
FIG. 6 is a top plan view of the enclosure shown in FIG. 1;  
FIG. 7 is a bottom plan view of the enclosure shown in FIG. 1;  
FIG. 8 is a top, front and right side perspective view of a second enclosure for sensors and transmitters for HVAC/R applications in accordance with our new design;  
FIG. 9 is a top, front and left side perspective view of the enclosure shown in FIG. 8;  
FIG. 10 is a front elevation view of the enclosure shown in FIG. 8;  
FIG. 11 is a right side elevation view of the enclosure shown in FIG. 8;  
FIG. 12 is a left side elevation view of the enclosure shown in FIG. 8;  
FIG. 13 is a top plan view of the enclosure shown in FIG. 8;  
and,  
FIG. 14 is a bottom plan view of the enclosure shown in FIG. 8.

**Related U.S. Application Data**

(63) Continuation of application No. 29/348,007, filed on Nov. 17, 2009, now abandoned.  
(51) **LOC (9) Cl.** ..... **10-04**  
(52) **U.S. Cl.** ..... **D10/49; D10/50; D10/52; D10/53**  
(58) **Field of Classification Search** ..... **D10/49-56;**  
**62/126.6, 93; 236/44 R, 94, DIG. 12; 374/208,**  
**374/100, 170, 173, E1.018, E7.035; 372/512;**  
**700/275-276**  
See application file for complete search history.

(56) **References Cited**

**U.S. PATENT DOCUMENTS**

D198,008 S	4/1964	Dunn et al.	
D375,904 S	11/1996	Fukuda	
D501,799 S	2/2005	Yamamoto et al.	
D556,607 S	12/2007	Beland et al.	
D580,800 S	11/2008	Hauk	
D610,026 S *	2/2010	Buber	D10/52
D665,281 S *	8/2012	Buber	D10/52

**OTHER PUBLICATIONS**

Author: Mescon Technologies, Inc.; Title: "Temperature Sensor-Transmitter Combo Ambient Temperature Measurements Model TSC-10"; Title of the item: Data Sheet/Product Brochure; Date of

The rears of the enclosures do not comprise any portion of the invention, and hence are not shown in the drawings.  
The broken line showings are for illustrative purposes only and form no part of the claimed design.

**1 Claim, 12 Drawing Sheets**

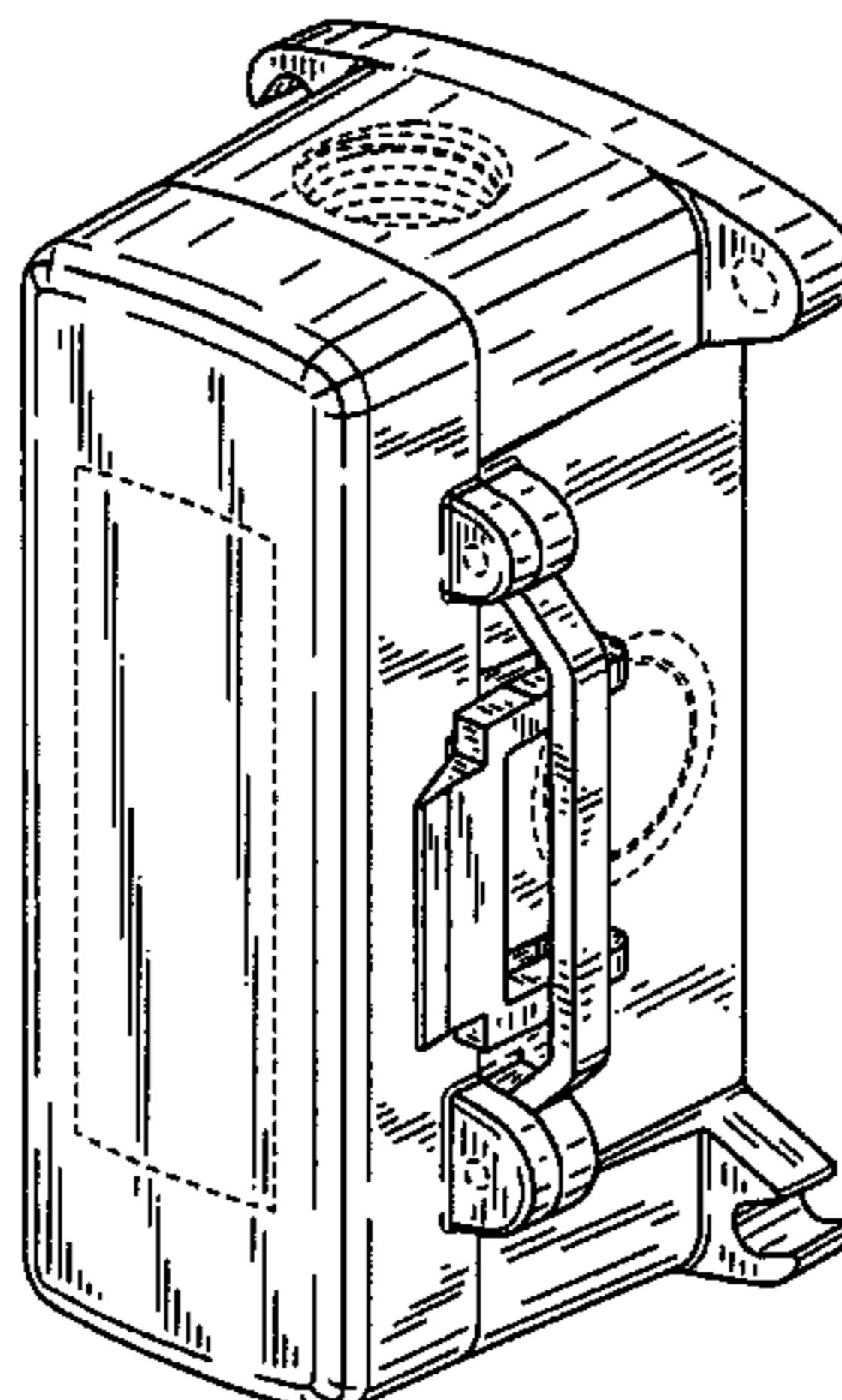

OTHER PUBLICATIONS

Author: Building Automation Products, Inc.; Title: "Building Automation Products, Inc. Sensors for HVAC/R 2007 Product Catalog Temperature—Humidity—Pressure—Air Quality—Accessories—Wireless—ETA Interface & Communication"; Title of the item: Portion of Product Catalog; Date of publication: 2007 (note that the year of publication is sufficiently earlier than the effective U.S. filed and any foreign priority date so that the particular month of publication is not in issue); Relevant pages: cover page and pp. 1-4, A1-A61, B1-B29, C1-C9, D1-D10, E1-E16, and H1-H16 (146 pages total); Publisher: Building Automation Products, Inc.; Where published: Gays Mills, WI, USA.

Author: Building Automation Products, Inc.; Title: "Building Automation Products, Inc. Sensors for HVAC/R 2008 Product Catalog

Temperature—Humidity—Pressure—Air Quality—Accessories—Wireless—ETA Interface & Communication"; Title of the item: Portion of Product Catalog; Date of publication: Jul. 2, 2008; Relevant page cover page and pp. A62-A63 (3 pages total); Publisher: Building Automation Products, Inc.; Where published: Gays Mills, WI, USA.

Author: Building Automation Products, Inc.; Title: "Building Automation Products, Inc. Sensors for Hvac/R 2008 Product Catalog Temperature—Humidity—Pressure—Air Quality—Accessories—Wireless—ETA Interface & Communication"; Title of the item: Portion of Product Catalog; Date of publication: Feb. 20, 2008; Relevant pages cover page and p. C10 (2 pages total); Publisher: Building Automation Products, Inc.; Where published: Gays Mills, WI, USA.

\* cited by examiner

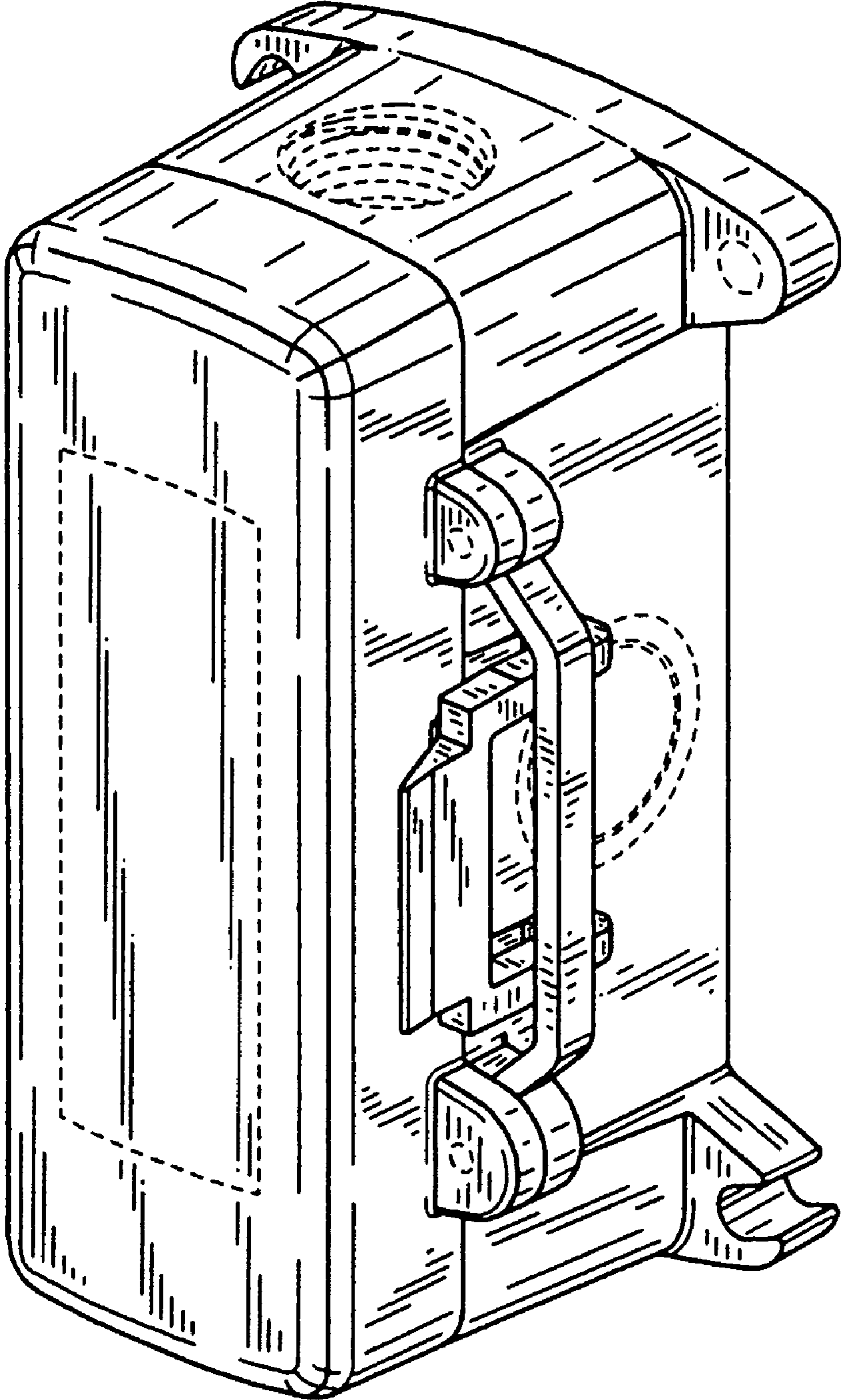

FIG. 1

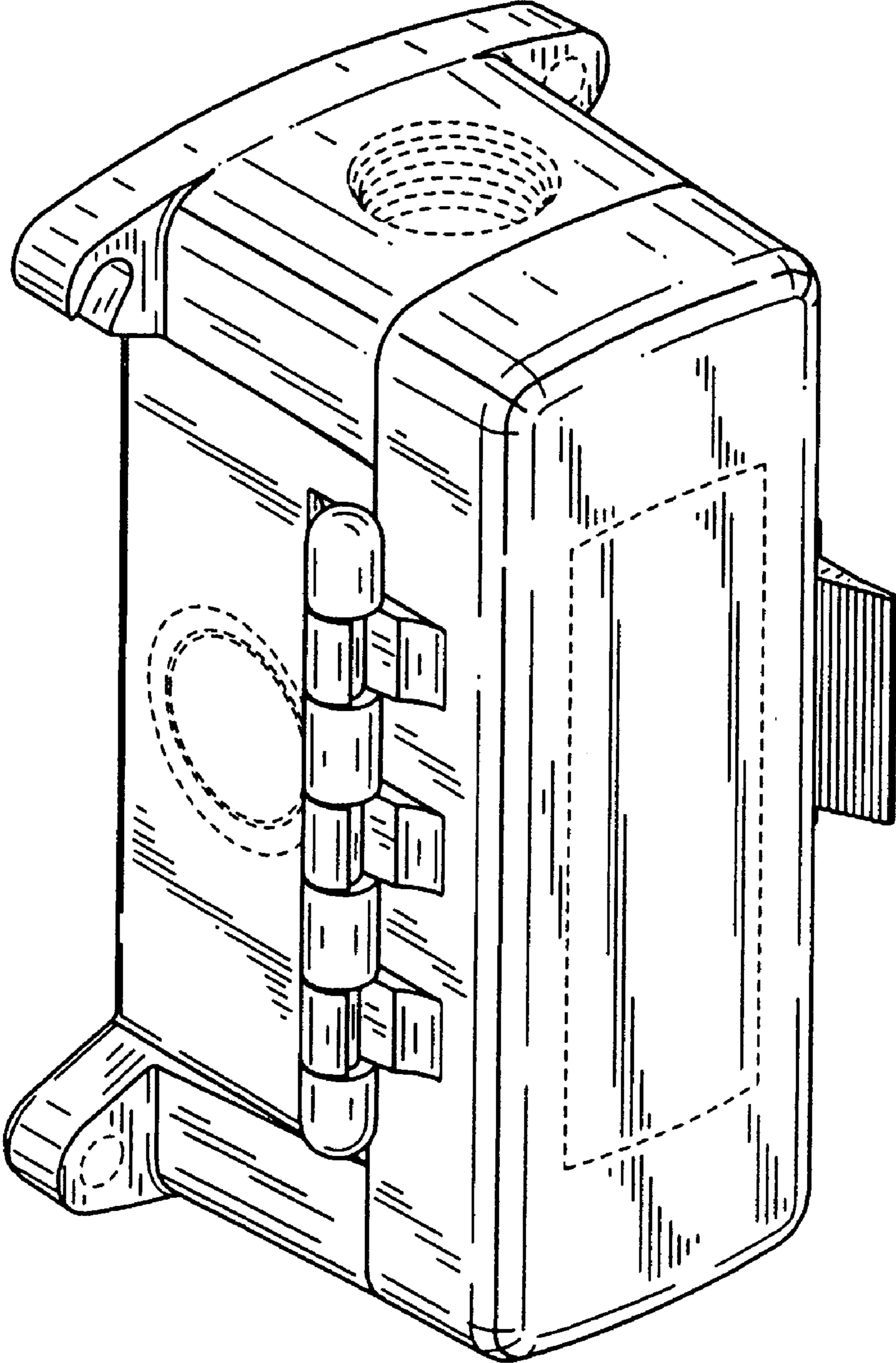

FIG. 2

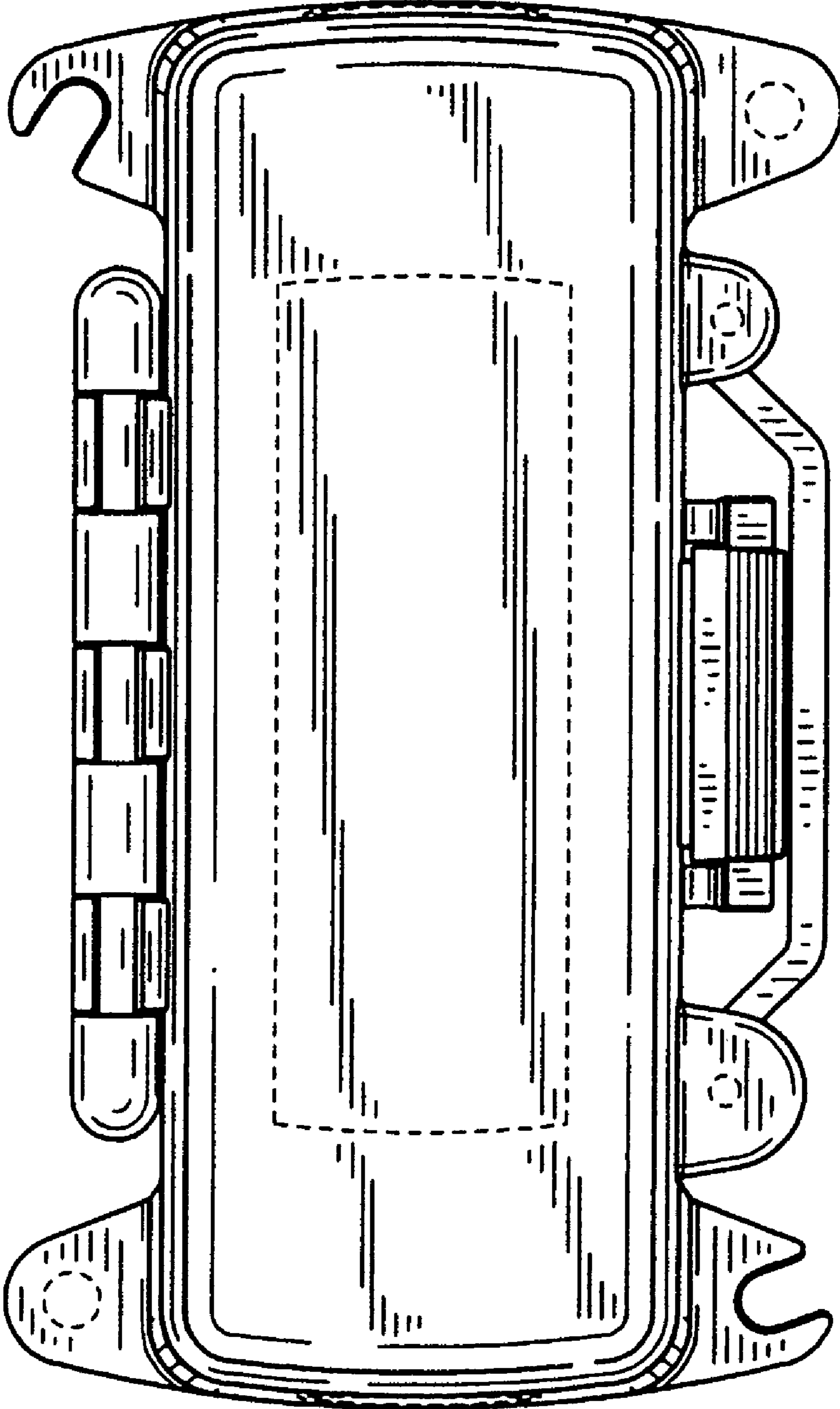

FIG. 3

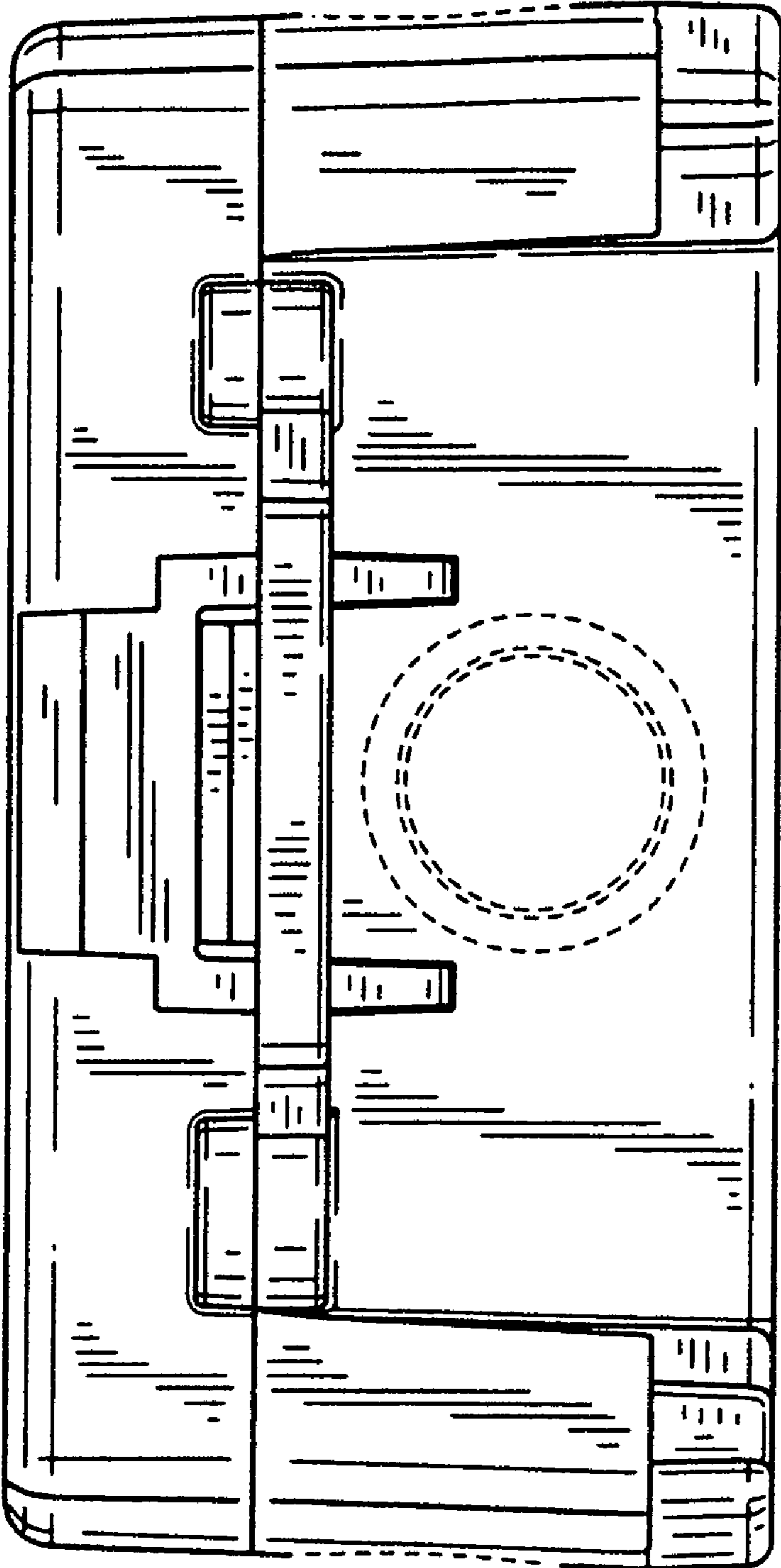

FIG. 4

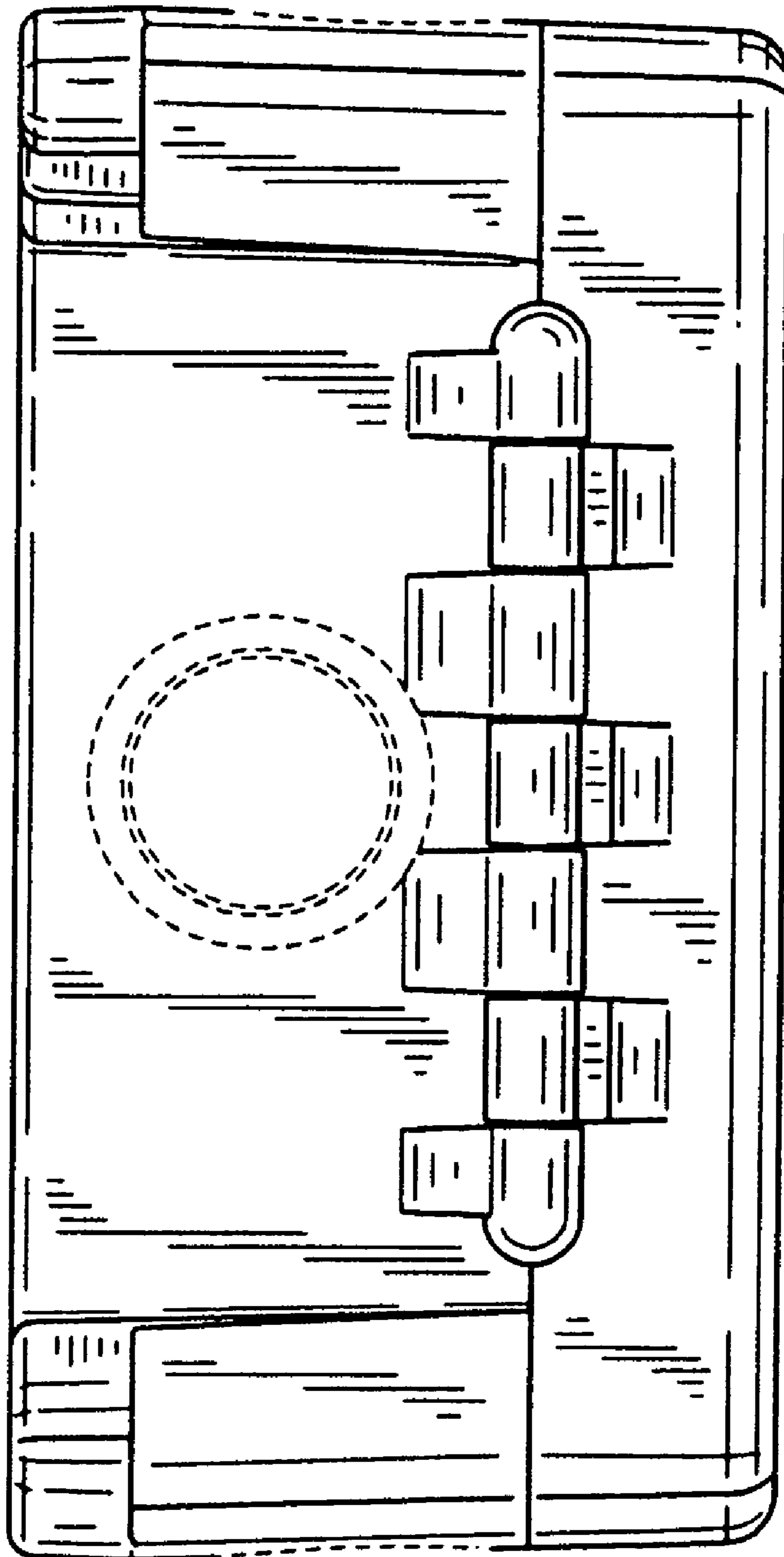

FIG. 5

FIG. 6

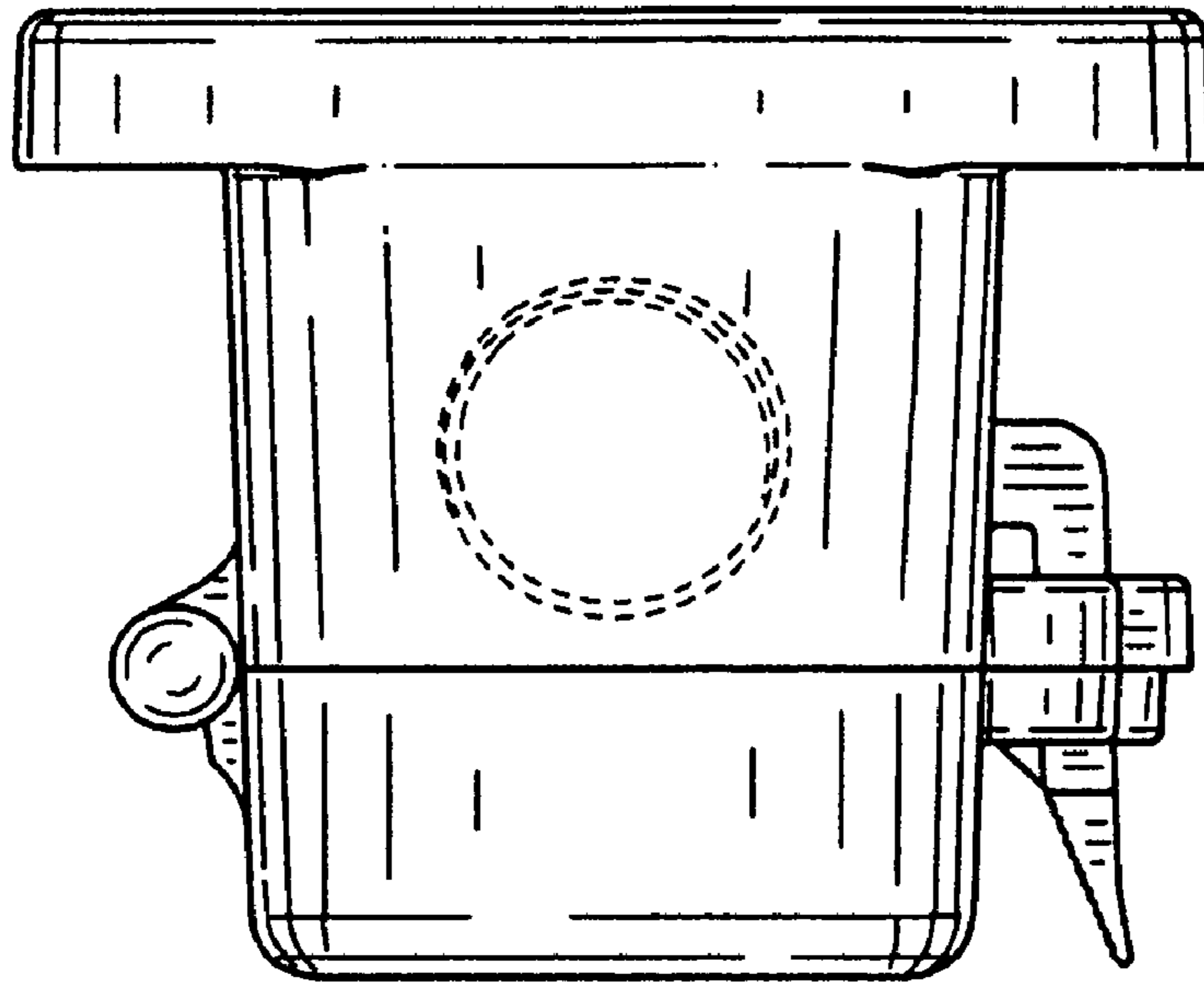
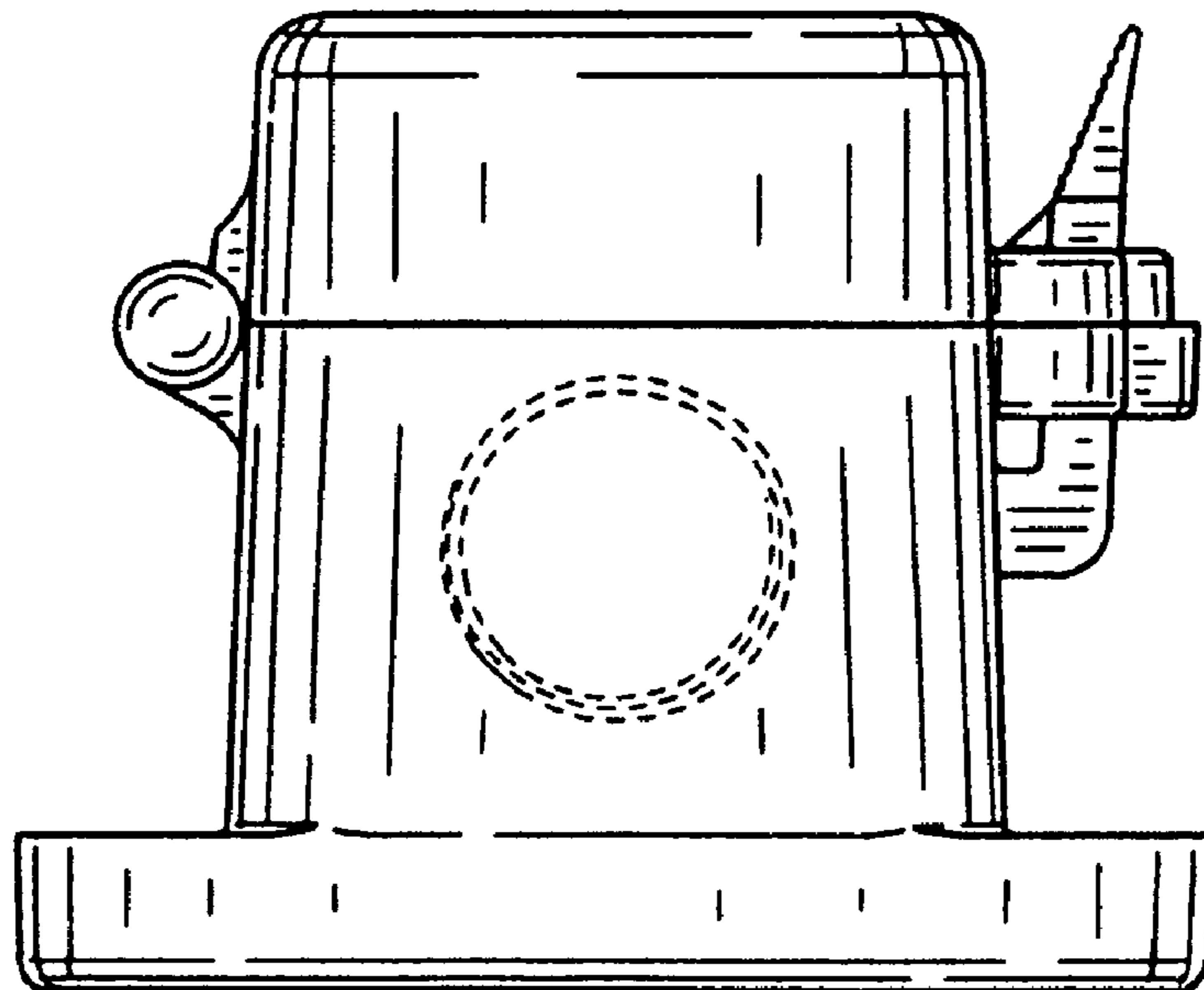

FIG. 7





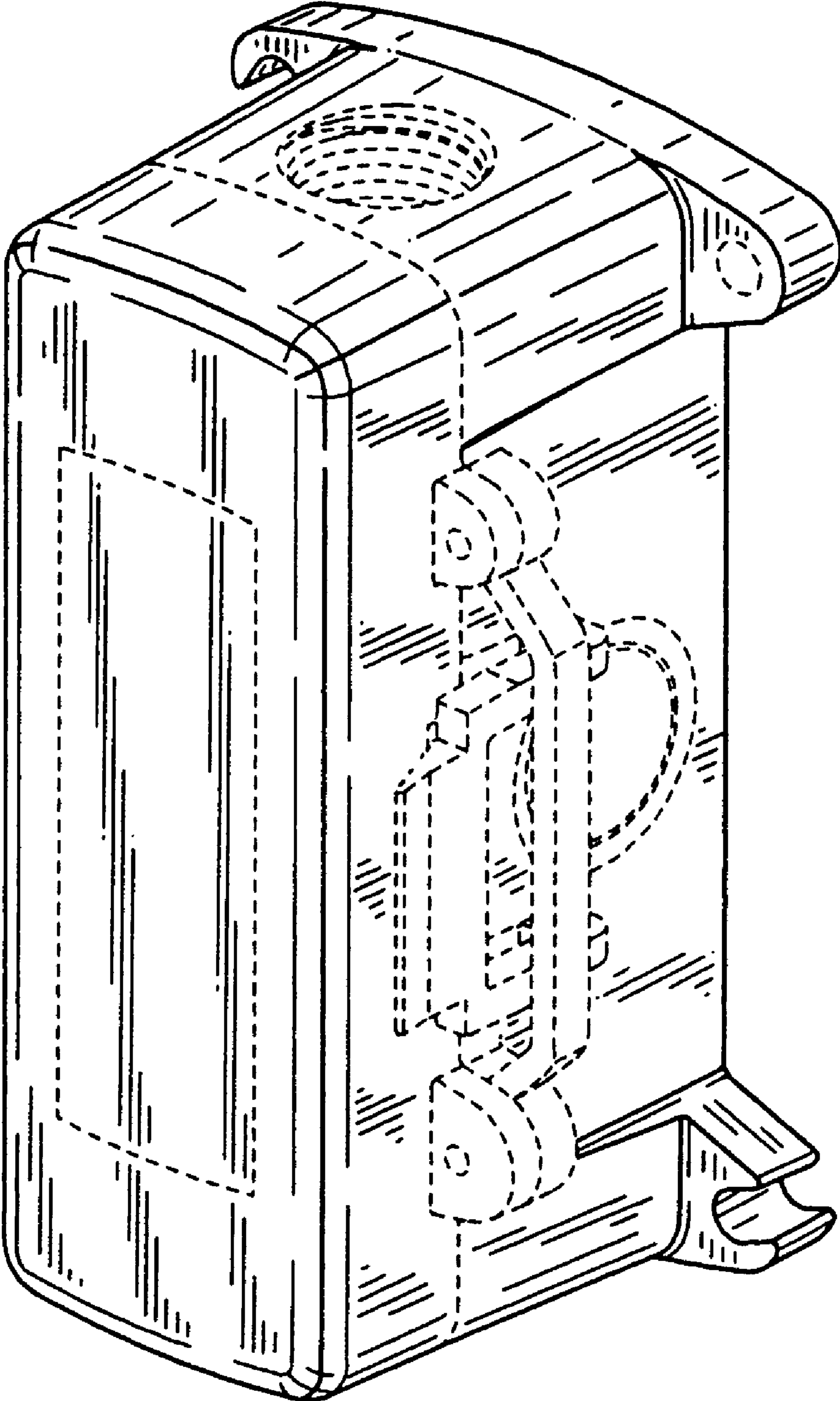

FIG. 8

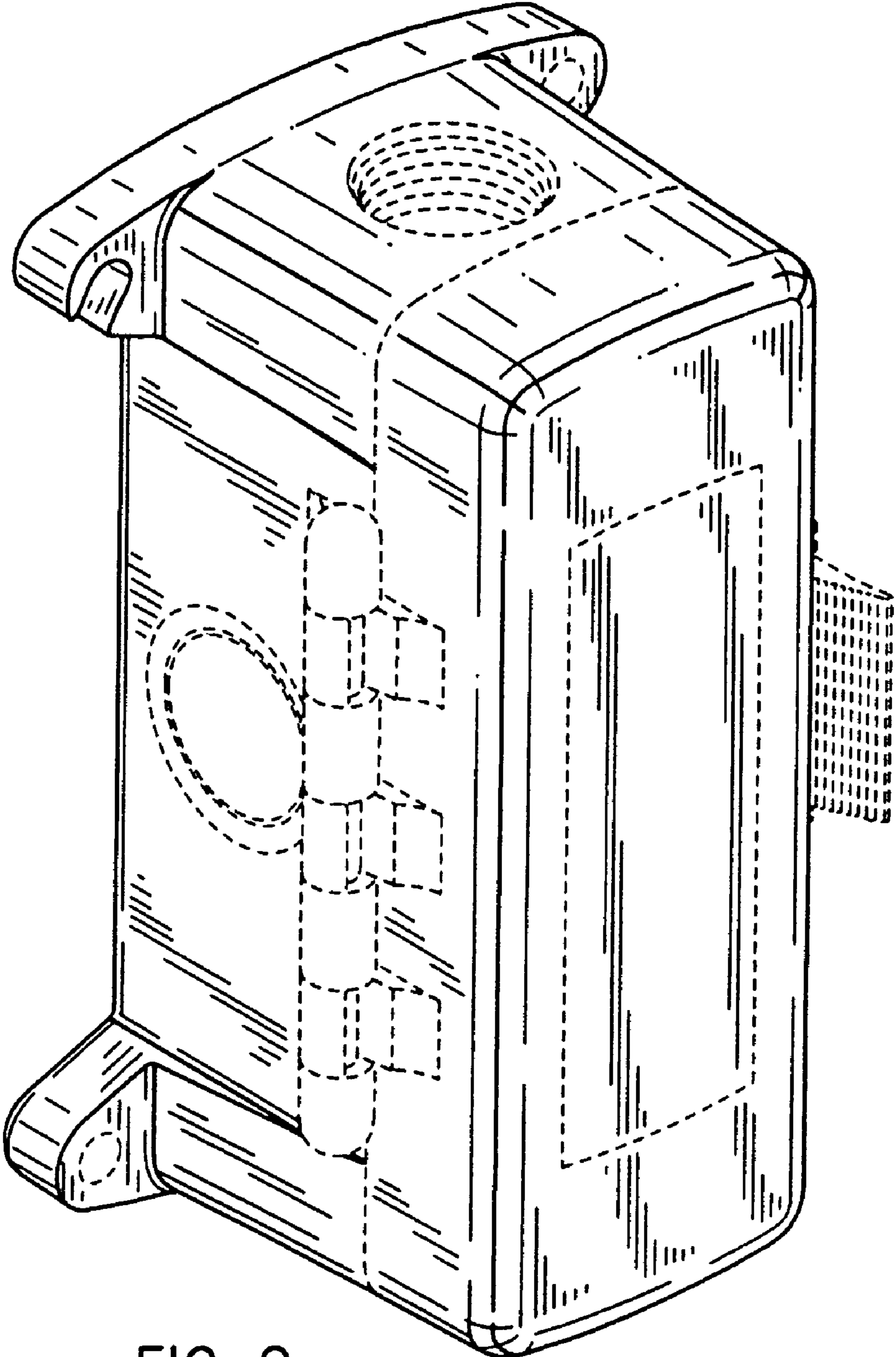

FIG. 9

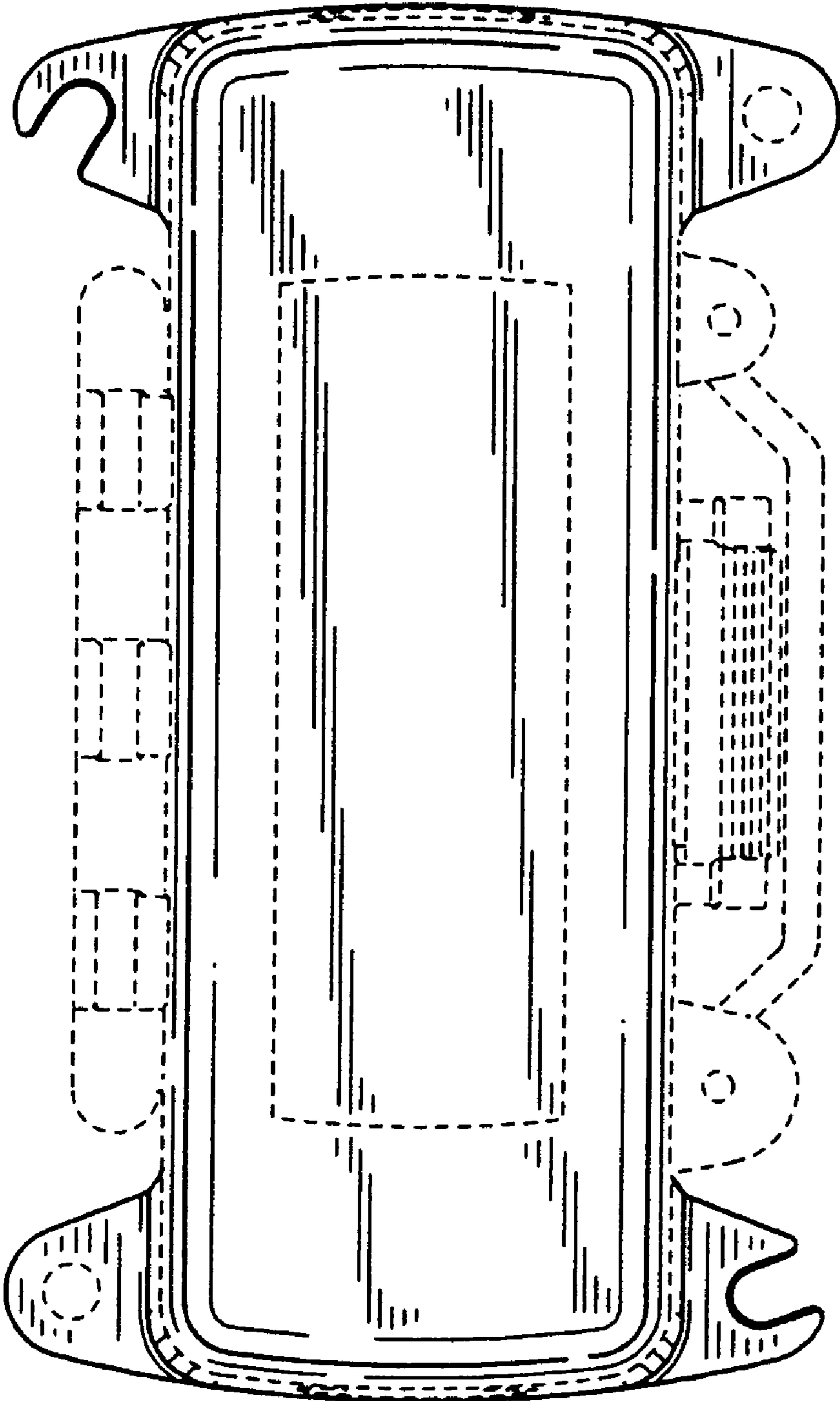

FIG. 10

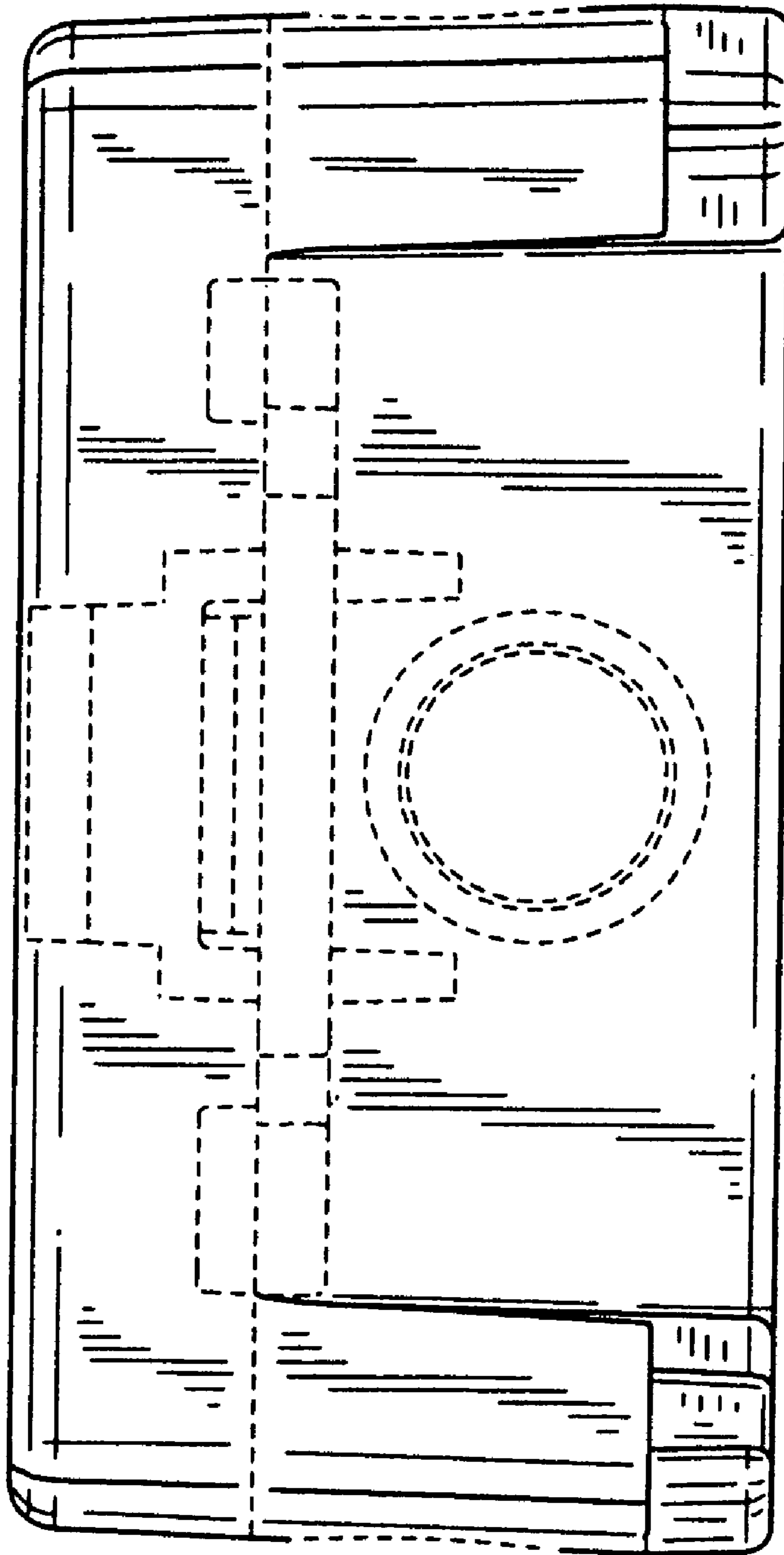

FIG. 11

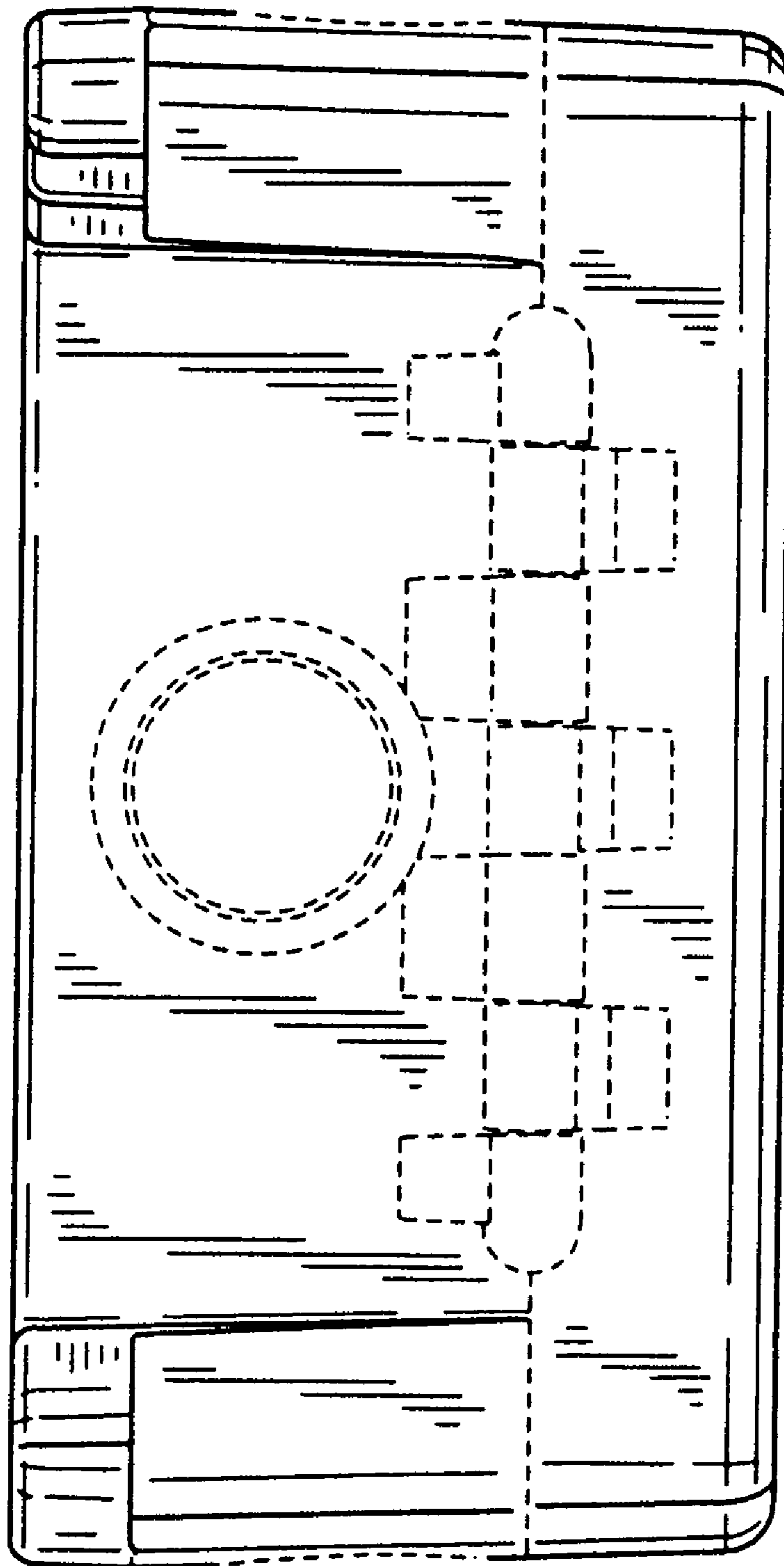

FIG. 12

FIG. 13

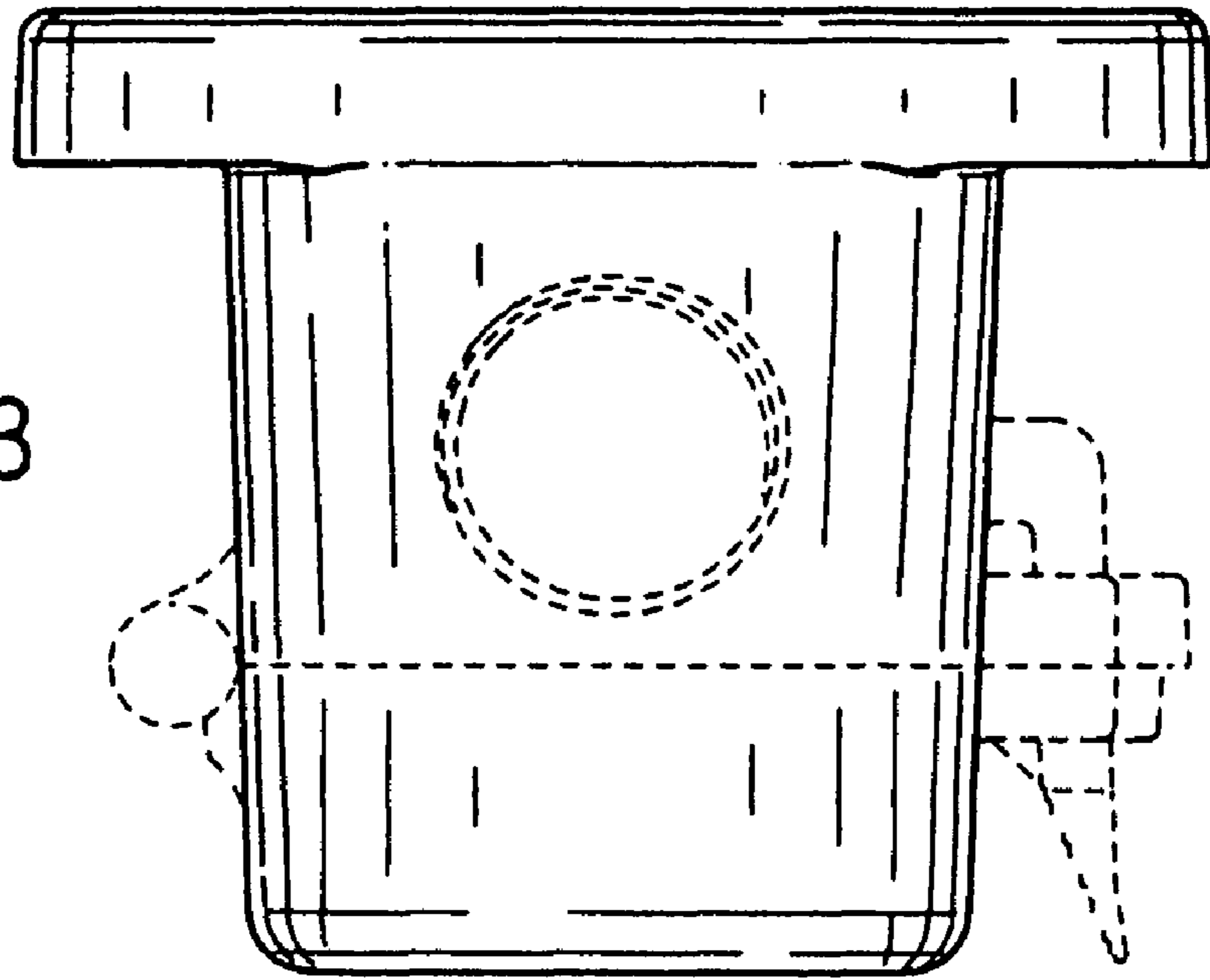

FIG. 14

