



US00D676902S

(12) **United States Design Patent**
Gilbert et al.

(10) **Patent No.:** **US D676,902 S**

(45) **Date of Patent:** **** Feb. 26, 2013**

(54) **OFFICE MACHINE**

(75) Inventors: **John B Gilbert**, Portland, OR (US);
Donald A Brown, Honeoye Falls, NY
(US)

(73) Assignee: **Xerox Corporation**, Norwalk, CT (US)

(**) Term: **14 Years**

(21) Appl. No.: **29/385,691**

(22) Filed: **Feb. 18, 2011**

(51) **LOC (9) Cl.** **14-02**

(52) **U.S. Cl.** **D18/50**

(58) **Field of Classification Search** D18/36-37,
D18/50, 54, 54.1, 55; D14/452-425, 463-470;
400/613, 613.1-613.4, 690, 690.1-690.4,
400/691-694

See application file for complete search history.

(56) **References Cited**

U.S. PATENT DOCUMENTS

| | | | | |
|--------------|--------|-------------------|-------|--------|
| D441,394 S * | 5/2001 | Kobayashi et al. | | D18/54 |
| D519,549 S * | 4/2006 | Tanio | | D18/50 |
| D522,044 S * | 5/2006 | Emmenegger et al. | | D18/50 |
| D523,069 S * | 6/2006 | Akahane et al. | | D18/50 |

| | | | | |
|--------------|---------|----------------|-------|--------|
| D552,167 S * | 10/2007 | Lee et al. | | D18/50 |
| D608,821 S * | 1/2010 | Tomono et al. | | D18/50 |
| D634,360 S * | 3/2011 | Brown et al. | | D18/55 |
| D643,874 S * | 8/2011 | Kim et al. | | D18/55 |
| D661,730 S * | 6/2012 | Gilbert et al. | | D18/55 |

* cited by examiner

Primary Examiner — Cathy A MacCormac

(74) *Attorney, Agent, or Firm* — Tallam I. Nguti

(57) **CLAIM**

The ornamental design for an office machine, as shown and described.

DESCRIPTION

FIG. 1 is a perspective view of an office machine in accordance with the present invention;
FIG. 2 is a front view thereof;
FIG. 3 is a right side view thereof;
FIG. 4 is a rear view thereof;
FIG. 5 is a left side view thereof;
FIG. 6 is a top plan view thereof; and,
FIG. 7 is a bottom plan view thereof.
The broken lines shown depict environmental subject matter only and do not form part of the claimed design.

1 Claim, 7 Drawing Sheets

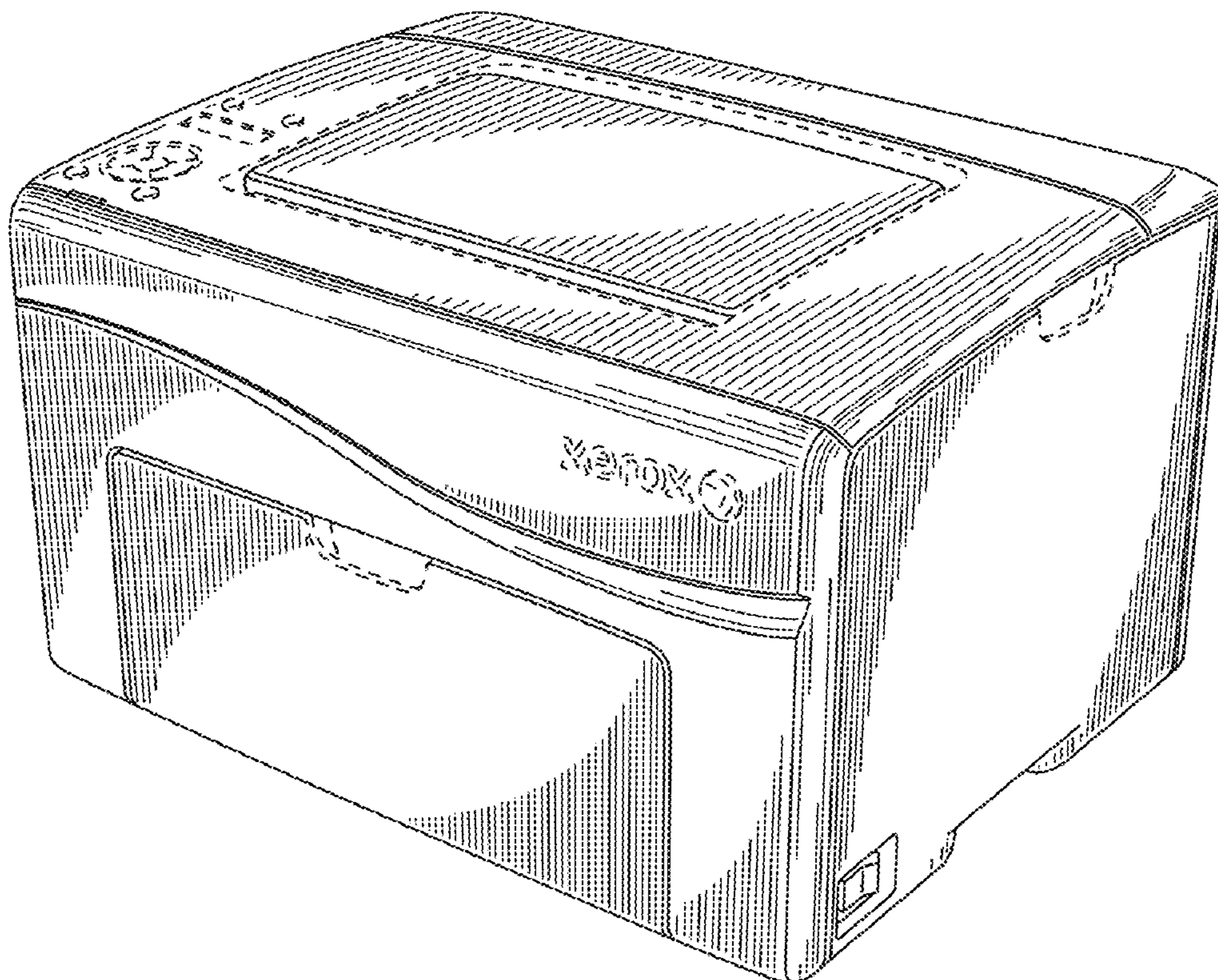

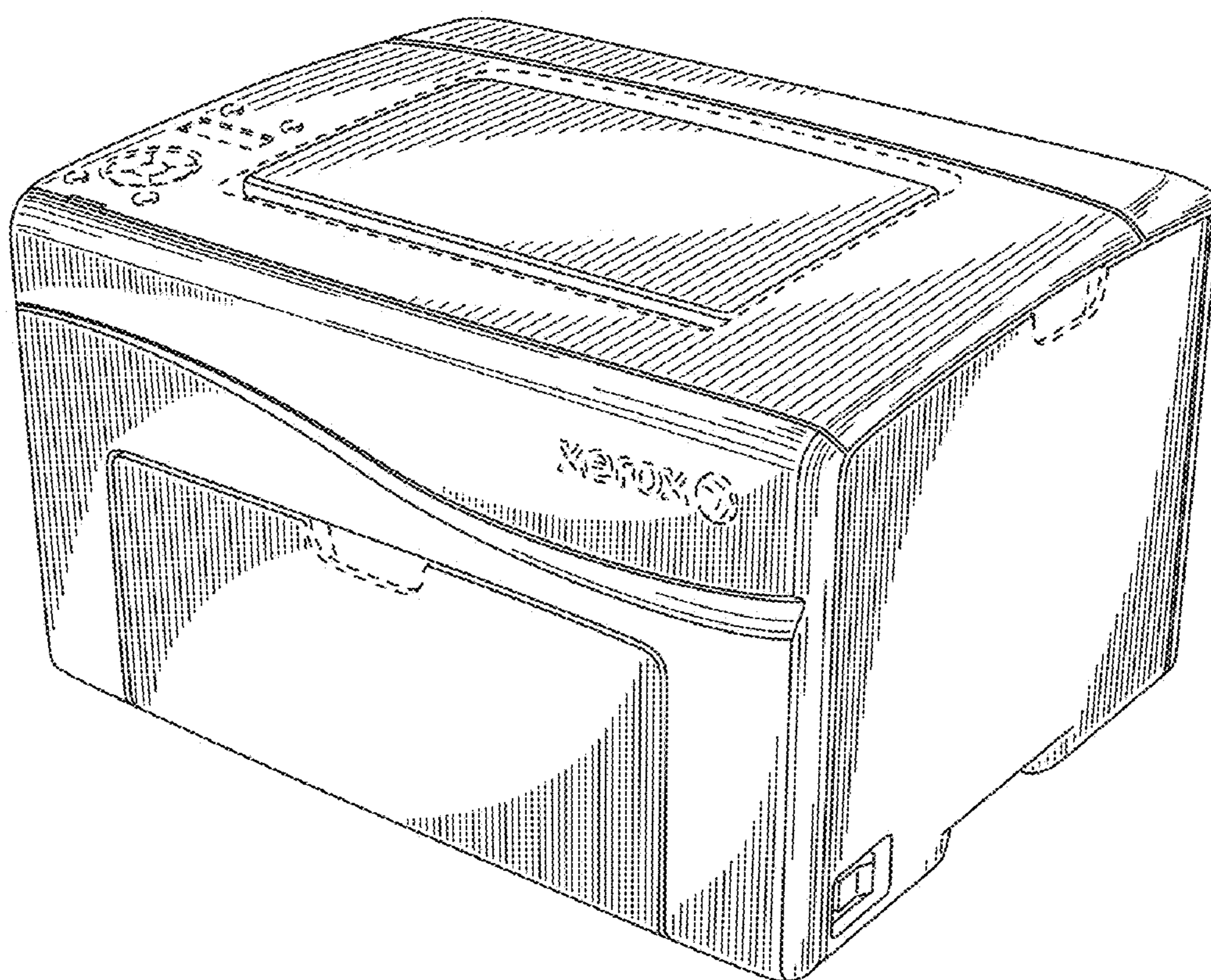

FIG. 1

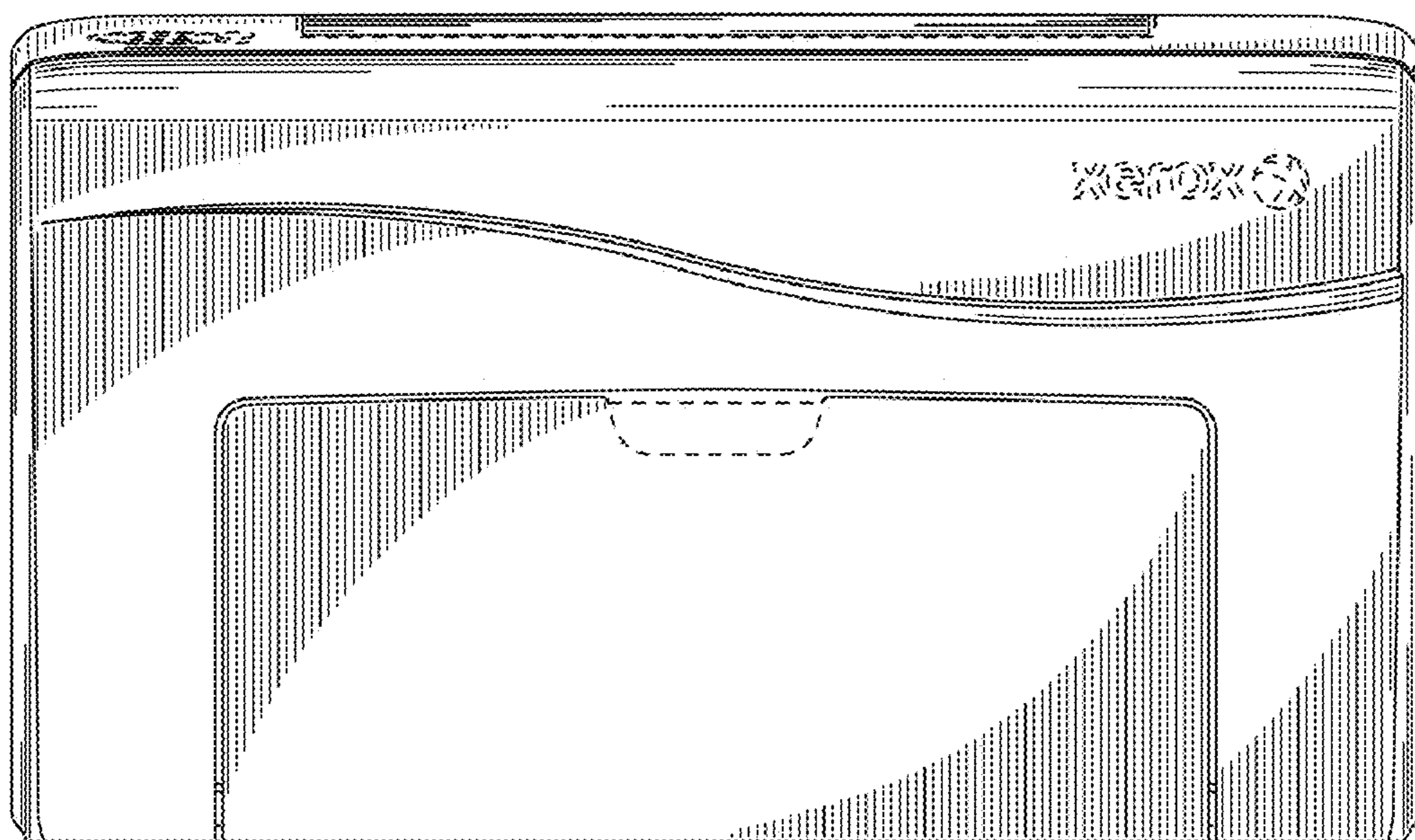

FIG. 2

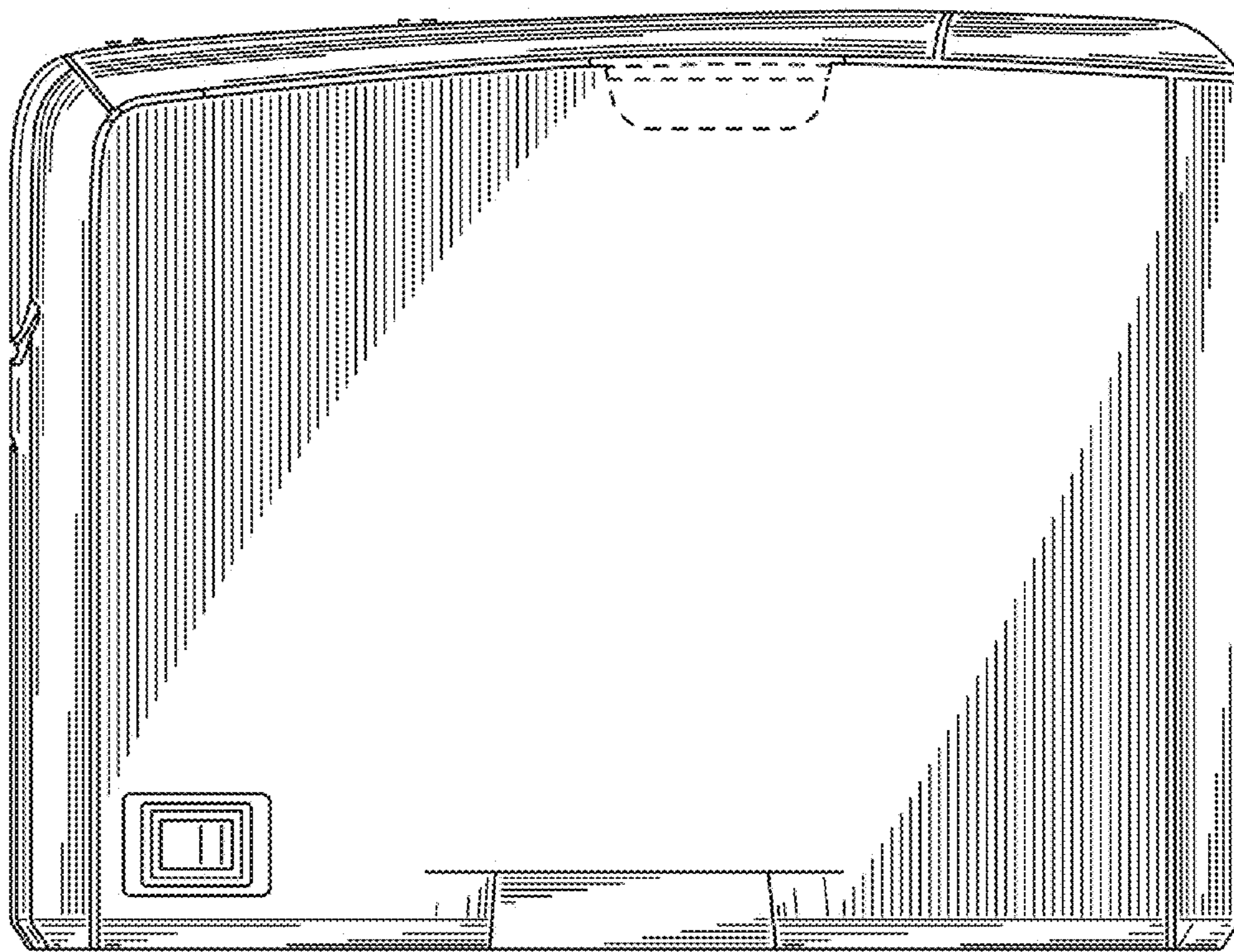

FIG. 3

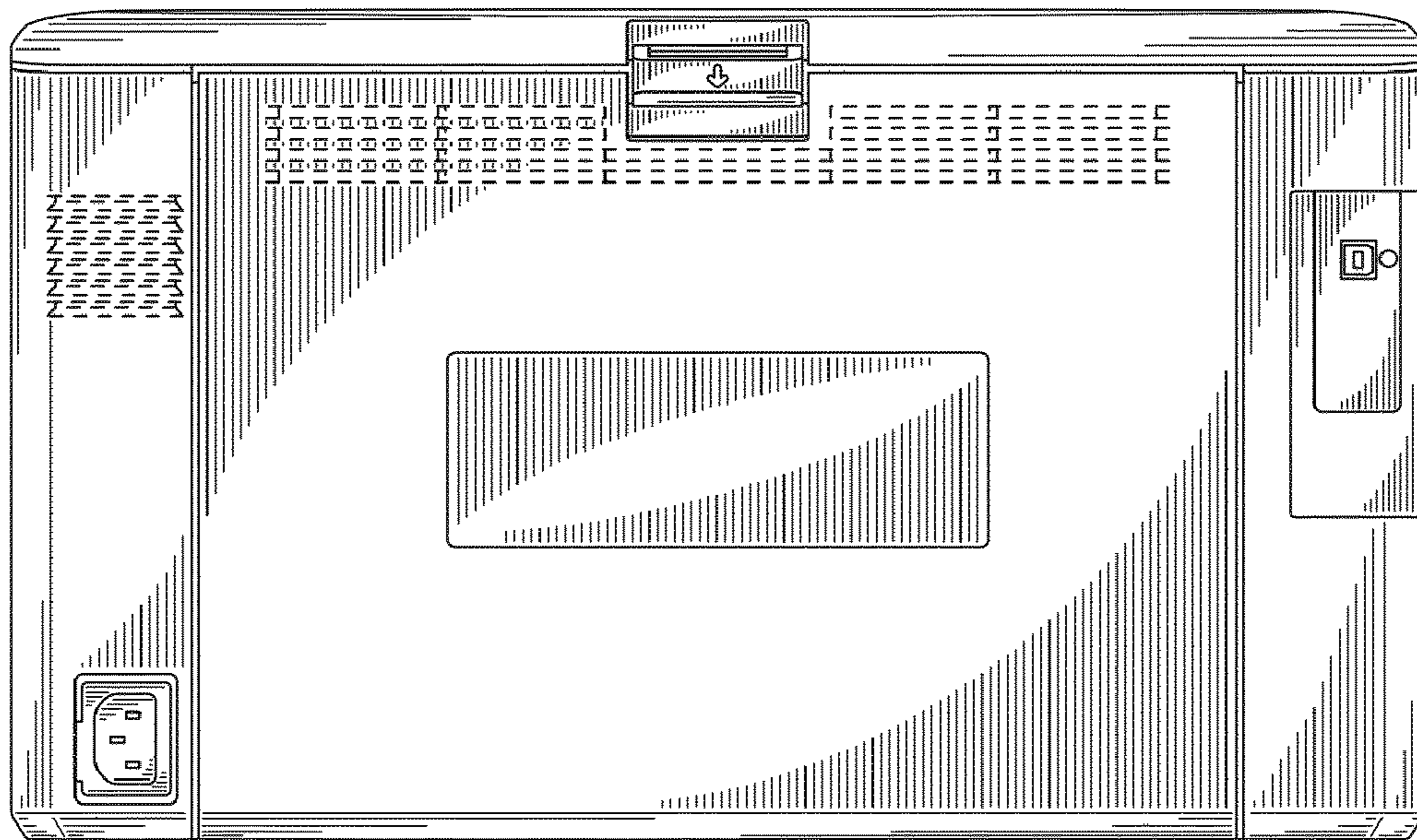

FIG. 4

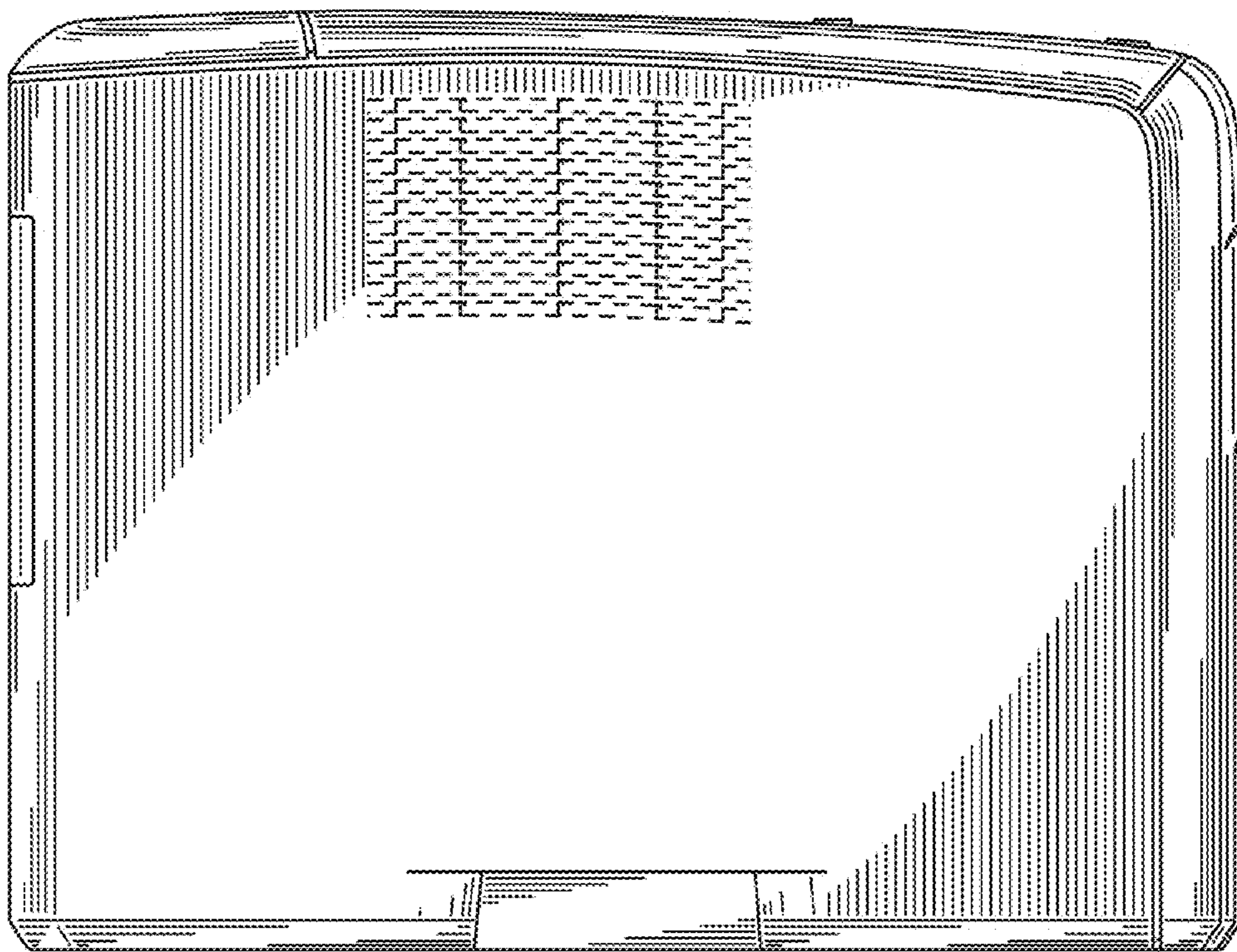

FIG. 5

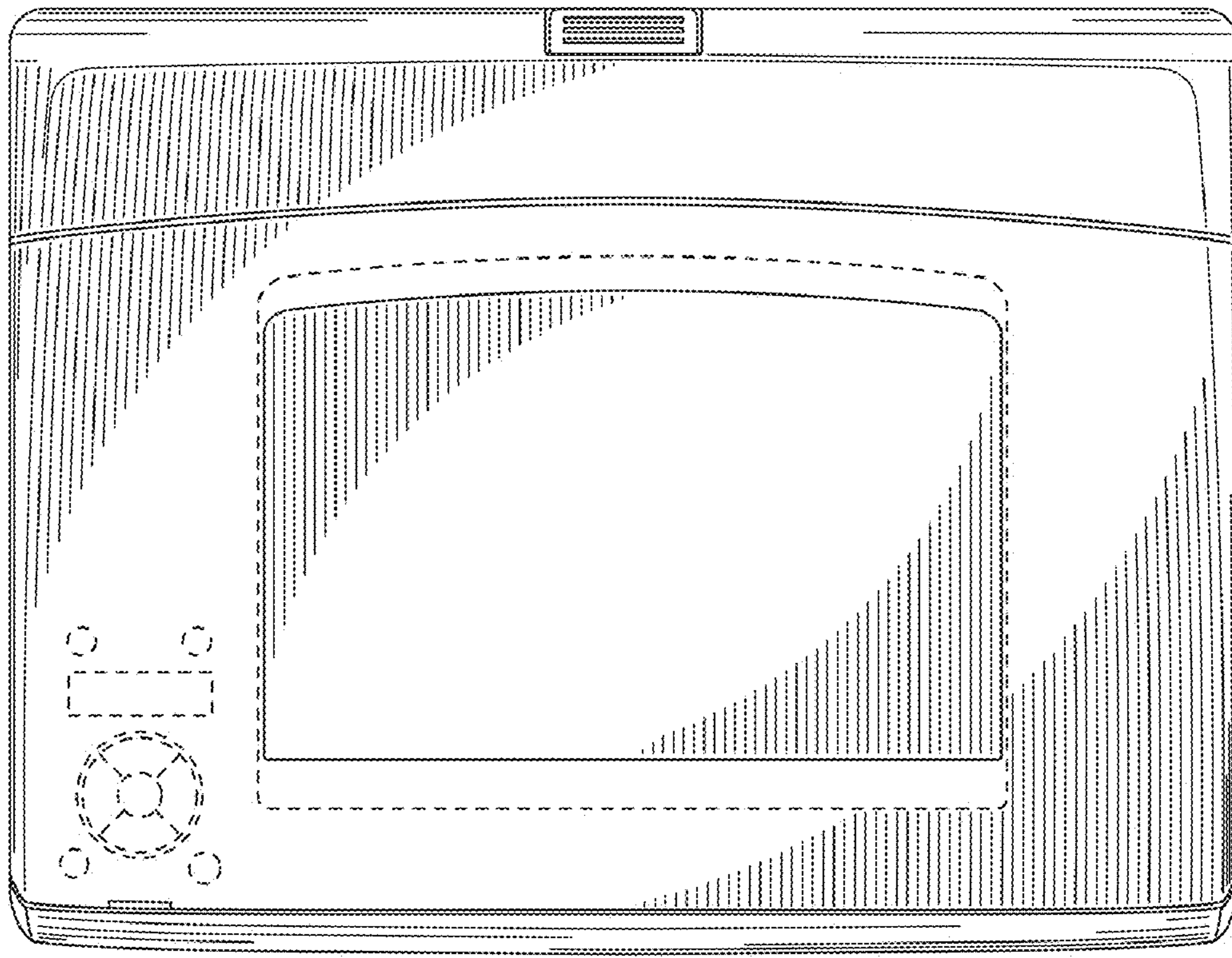

FIG. 6

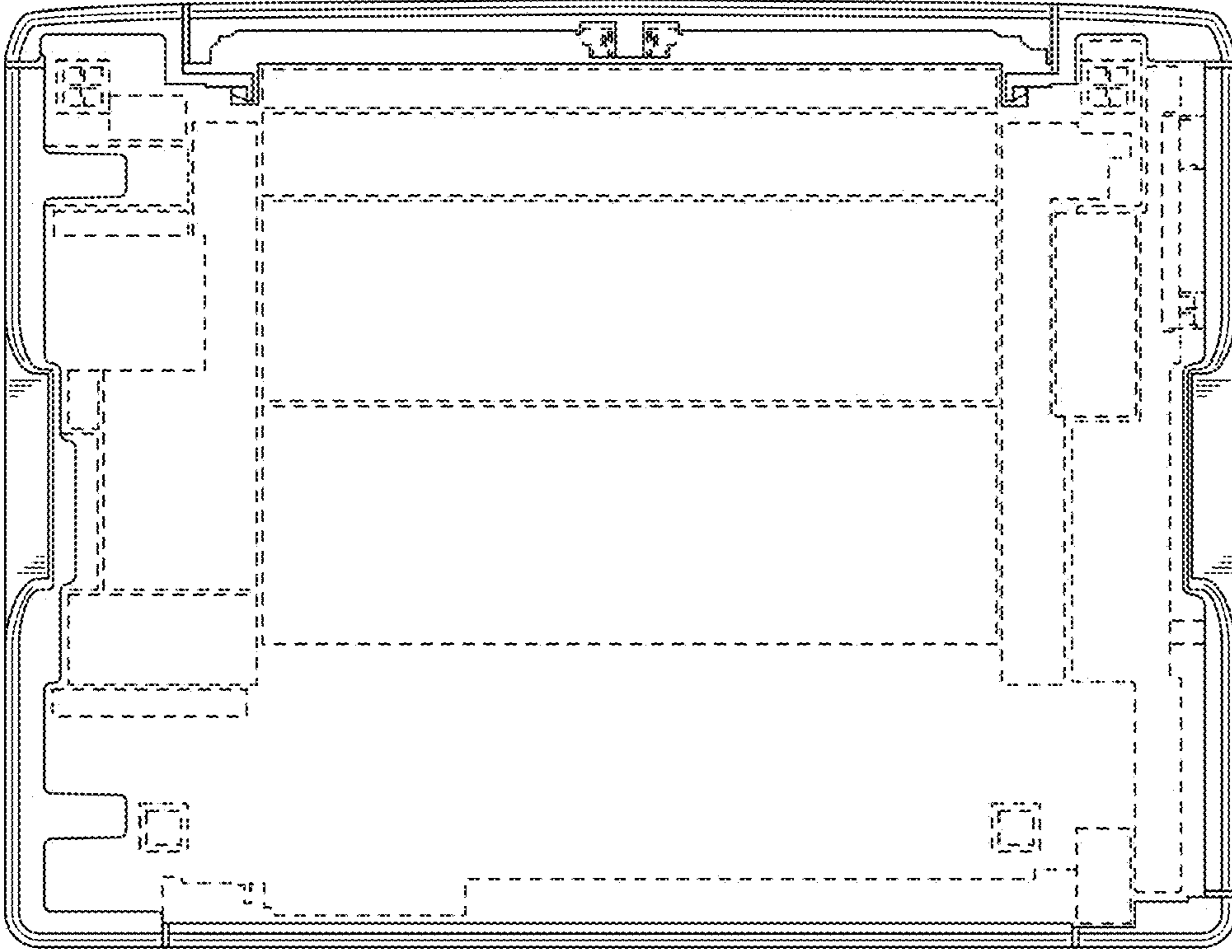

FIG. 7