



US00D676900S

(12) **United States Design Patent**
Ohno et al.

(10) **Patent No.:** **US D676,900 S**
(45) **Date of Patent:** **** Feb. 26, 2013**

(54) **POINT OF SALES TERMINAL**
(75) Inventors: **Akio Ohno**, Fukuoka (JP); **Toshihiro Nakashima**, Fukuoka (JP); **Yasuki Yamakawa**, Fukuoka (JP); **Takayuki Takahashi**, Kanagawa (JP); **Kenzo Horie**, Fukuoka (JP)

(73) Assignee: **Panasonic Corporation**, Osaka (JP)

(**) Term: **14 Years**

(21) Appl. No.: **29/416,768**

(22) Filed: **Mar. 27, 2012**

(30) **Foreign Application Priority Data**

Dec. 19, 2011 (JP) 2011-029372

(51) **LOC (9) Cl.** **18-01**

(52) **U.S. Cl.** **D18/4.4; D18/12.3**

(58) **Field of Classification Search** D14/336, D14/371-376, 387; D18/3.1-3.3, 4.1-4.6, D18/12.1-12.3; D21/324, 325, 332; D99/28, D99/34-36, 43; 235/1 E, 2, 7 R, 12, 22, 235/33, 51, 52; 705/12, 15-18, 43
See application file for complete search history.

(56) **References Cited**

U.S. PATENT DOCUMENTS

D336,637 S * 6/1993 Abe et al. D14/337
D362,427 S 9/1995 Mizusugi et al.
D451,535 S 12/2001 Lee
D451,917 S * 12/2001 Rahemtulla et al. D14/337

D458,255 S * 6/2002 Hsu D14/373
D507,592 S 7/2005 Mizusugi et al.
D508,519 S 8/2005 Kuramochi et al.
D527,760 S 9/2006 Ono
D569,898 S * 5/2008 Masuda D18/4.5
D586,566 S * 2/2009 Ko et al. D6/312
D587,296 S 2/2009 Kuramochi
D594,055 S * 6/2009 Hagiwara et al. D18/4.5
D640,252 S * 6/2011 Kuroda et al. D18/4.5
D647,898 S * 11/2011 Haller et al. D14/336

* cited by examiner

Primary Examiner — Garth Rademaker

(74) *Attorney, Agent, or Firm* — Brinks Hofer Gilson & Lione

(57) **CLAIM**

We claim the ornamental design for a point of sales terminal, as shown and described.

DESCRIPTION

FIG. 1 is a front perspective view of a point of sales terminal of the present invention;
FIG. 2 is a rear perspective view thereof;
FIG. 3 is a front view thereof;
FIG. 4 is a rear view thereof;
FIG. 5 is a first side view thereof;
FIG. 6 is a second side view thereof;
FIG. 7 is a top view thereof; and
FIG. 8 is a bottom view thereof.

The broken lines shown represent unclaimed subject matter and form no part of the claimed design. Additionally, the unevenly broken lines in the drawings define the limits of the claimed design.

1 Claim, 8 Drawing Sheets

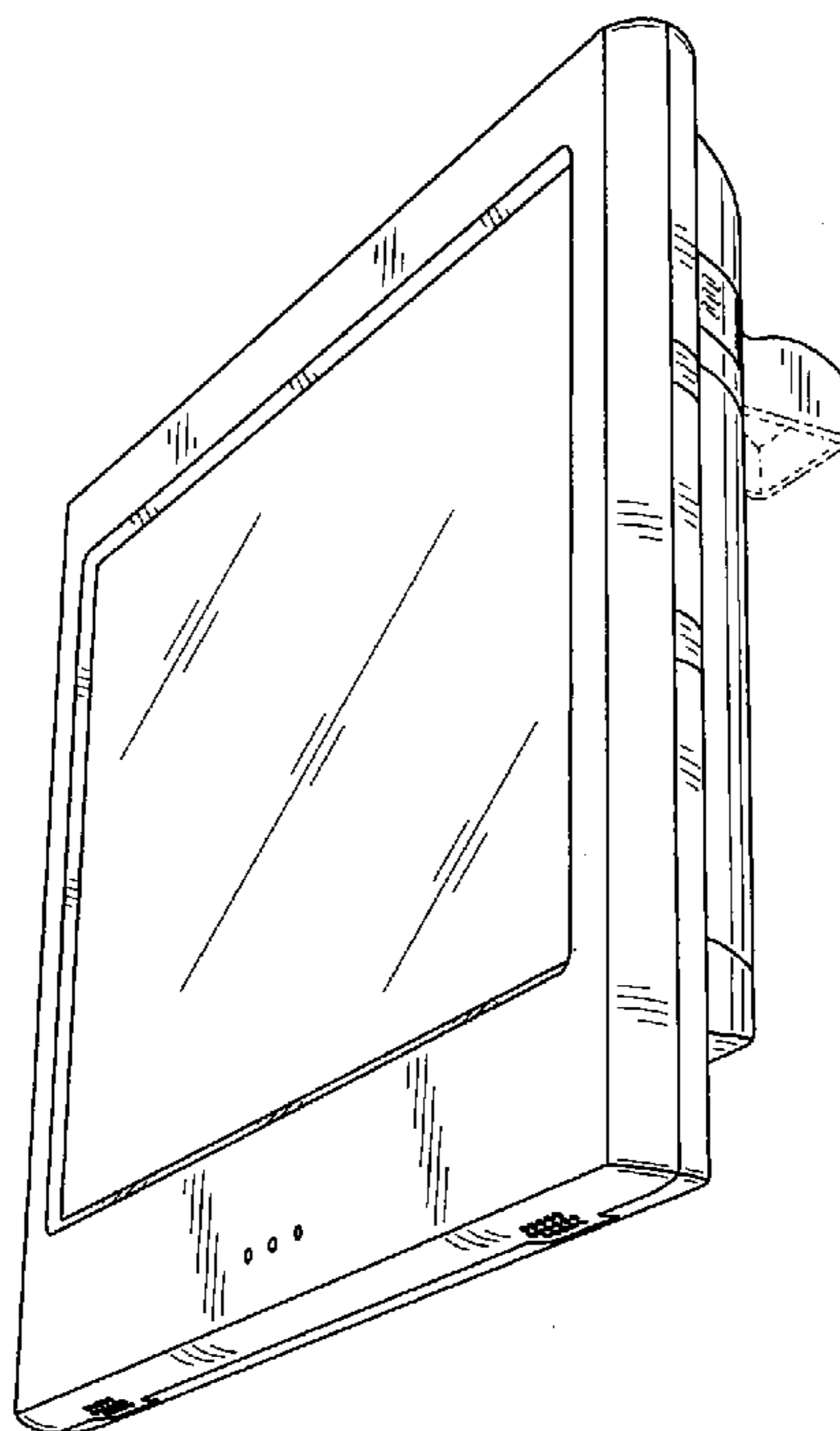

FIG. 1

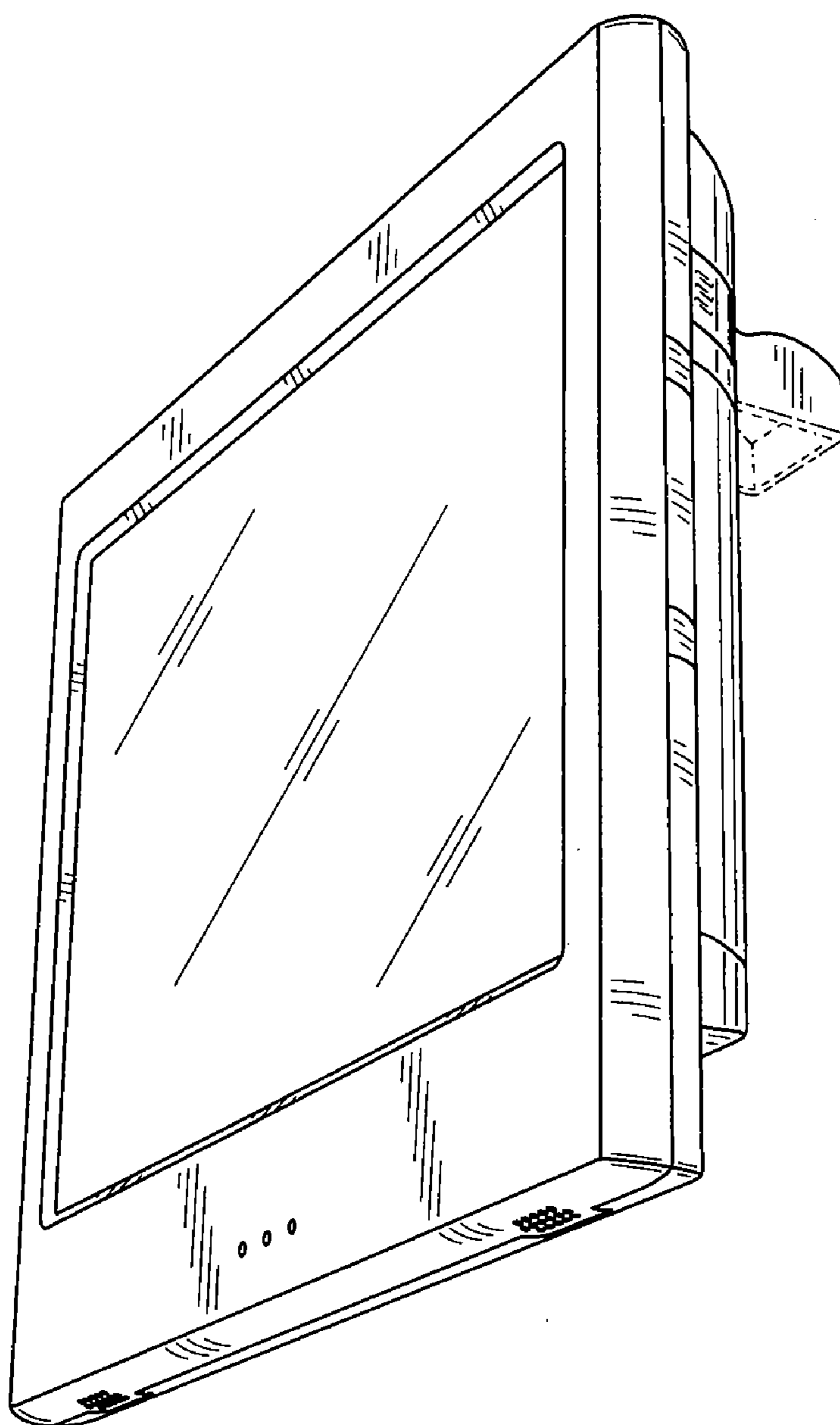

FIG.2

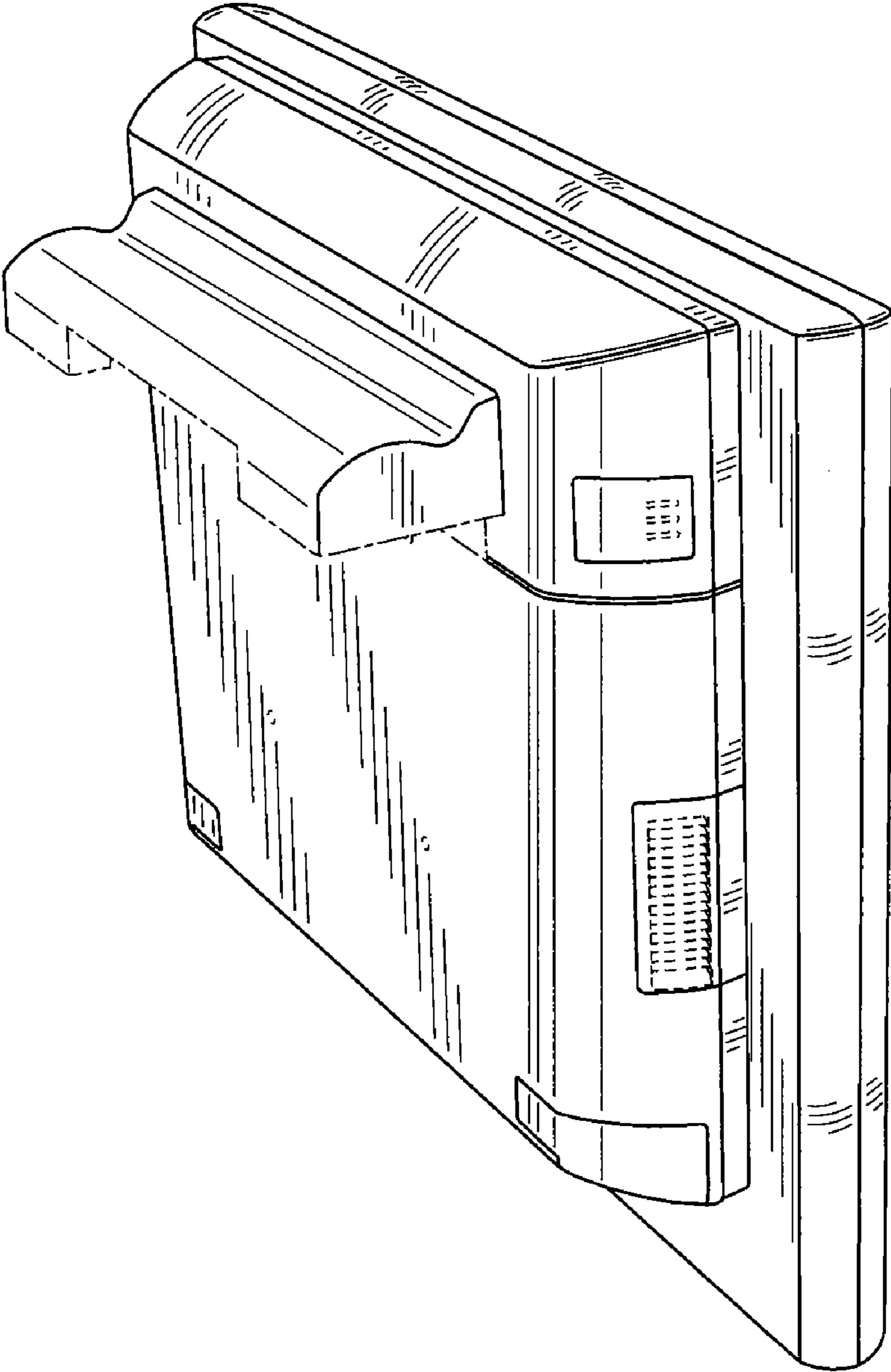

FIG.3

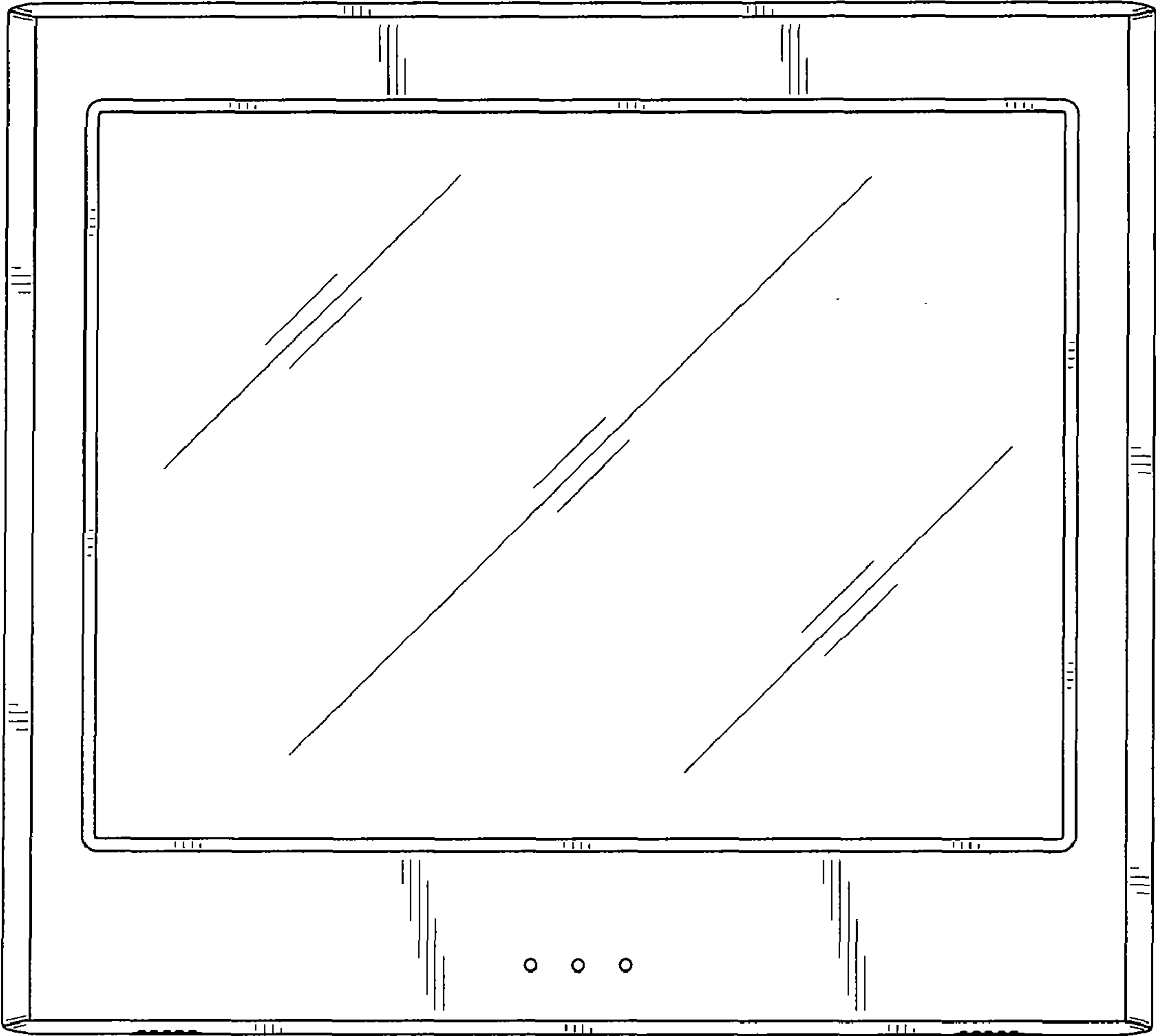

FIG.4

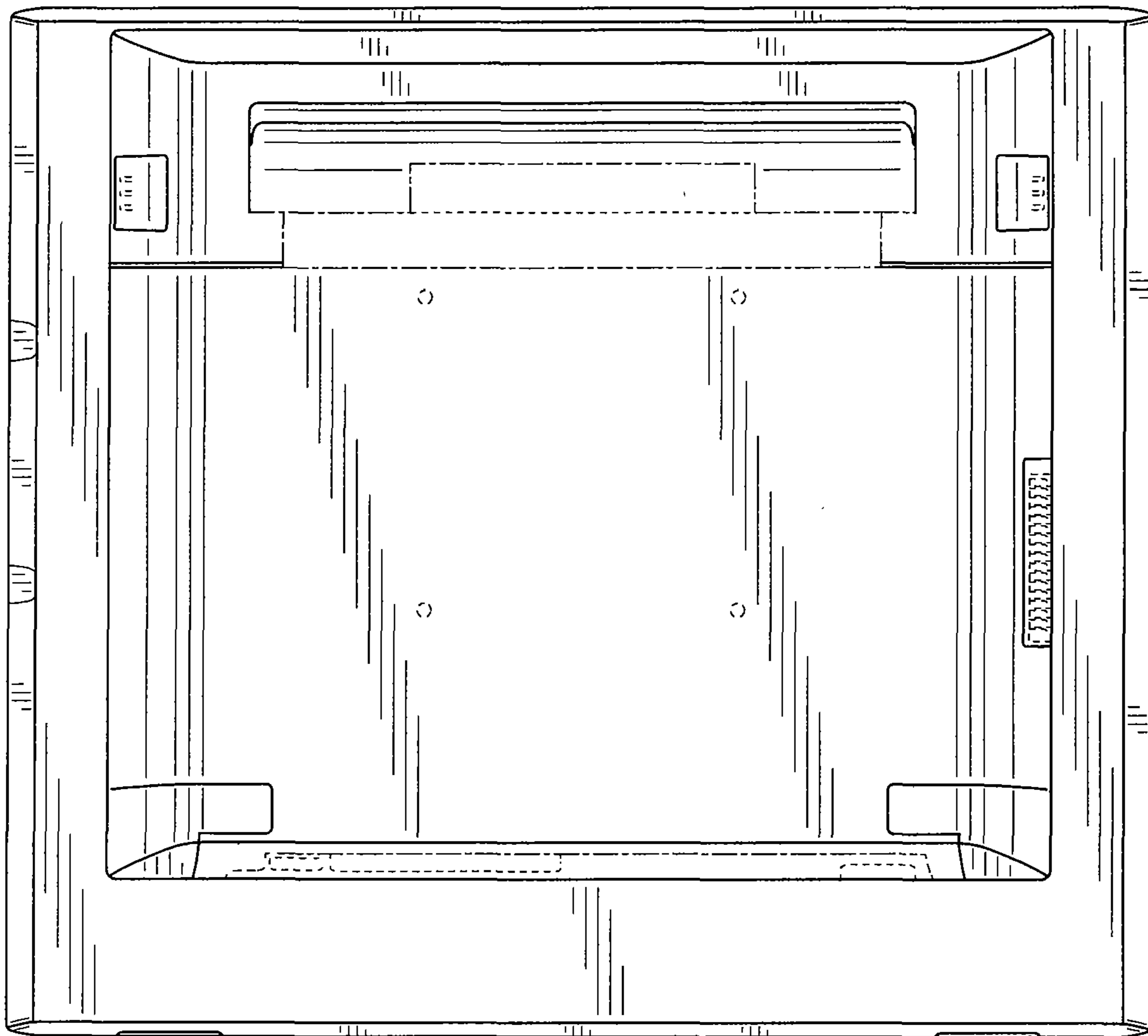

FIG.5

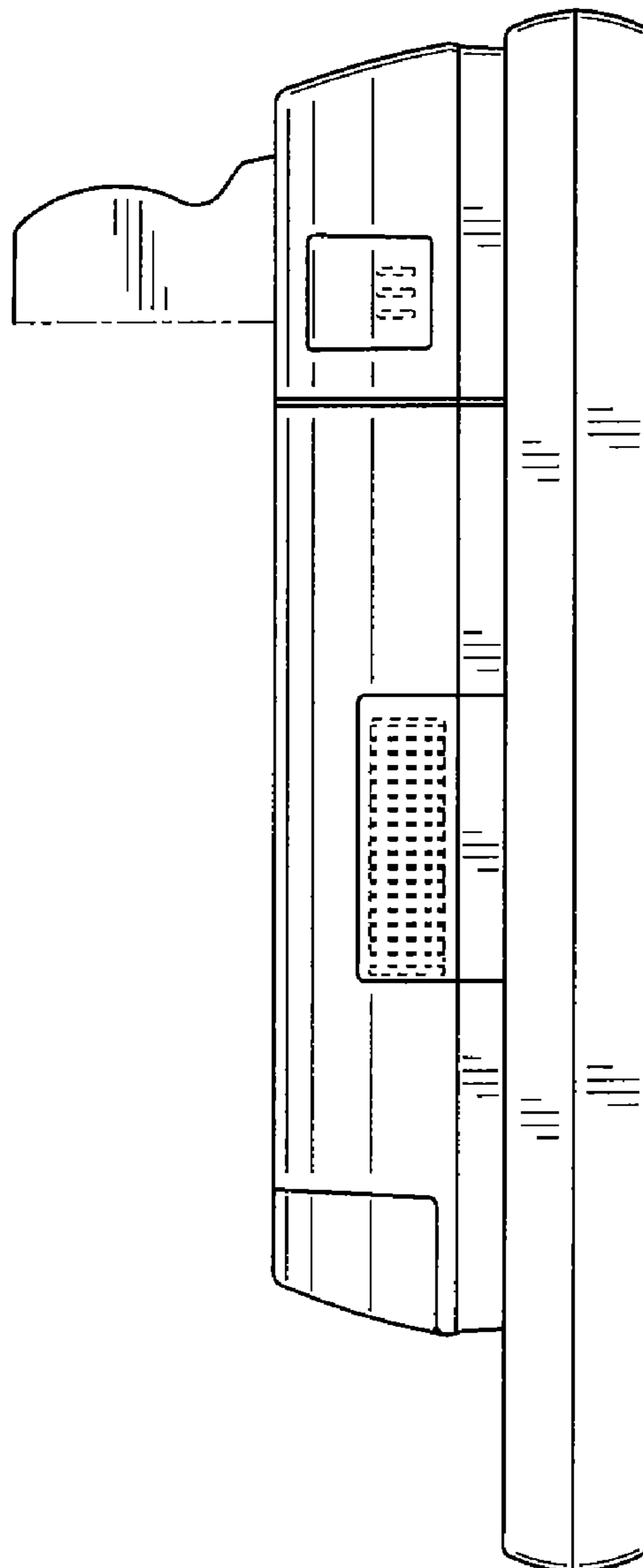

FIG.6

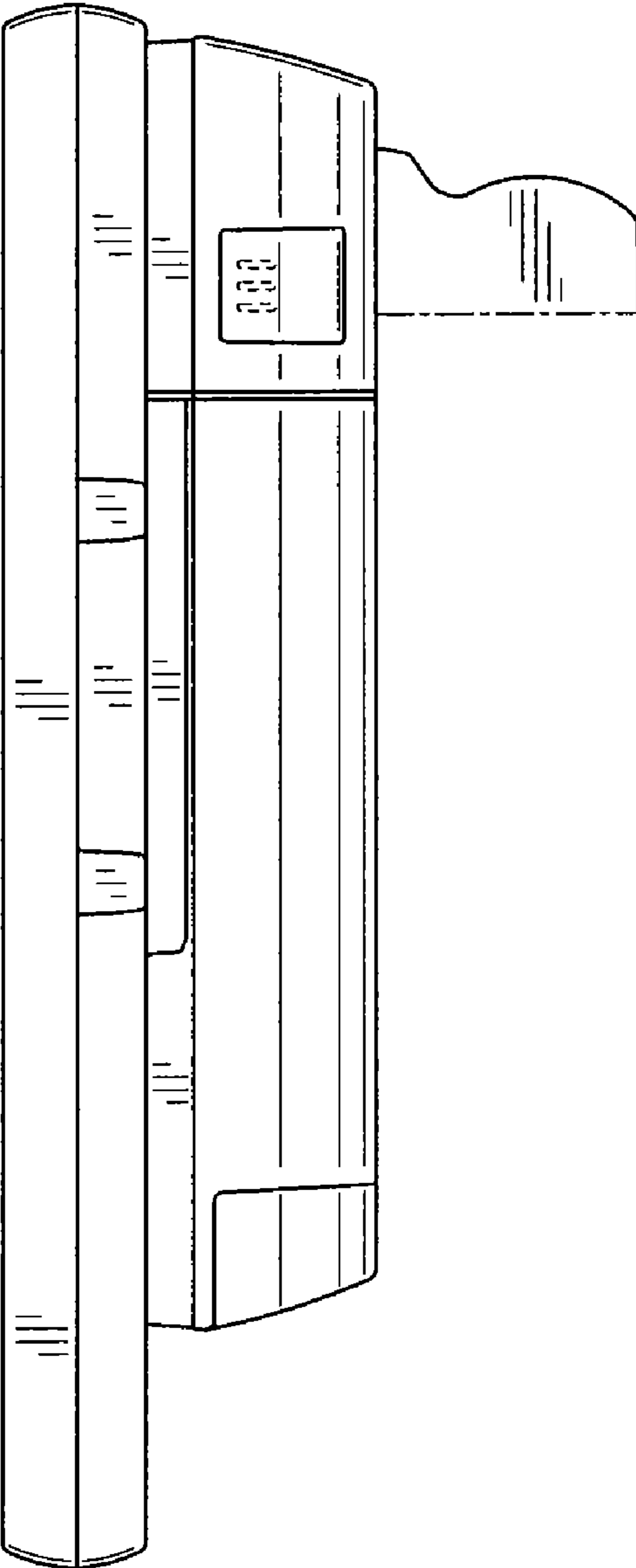

FIG.7

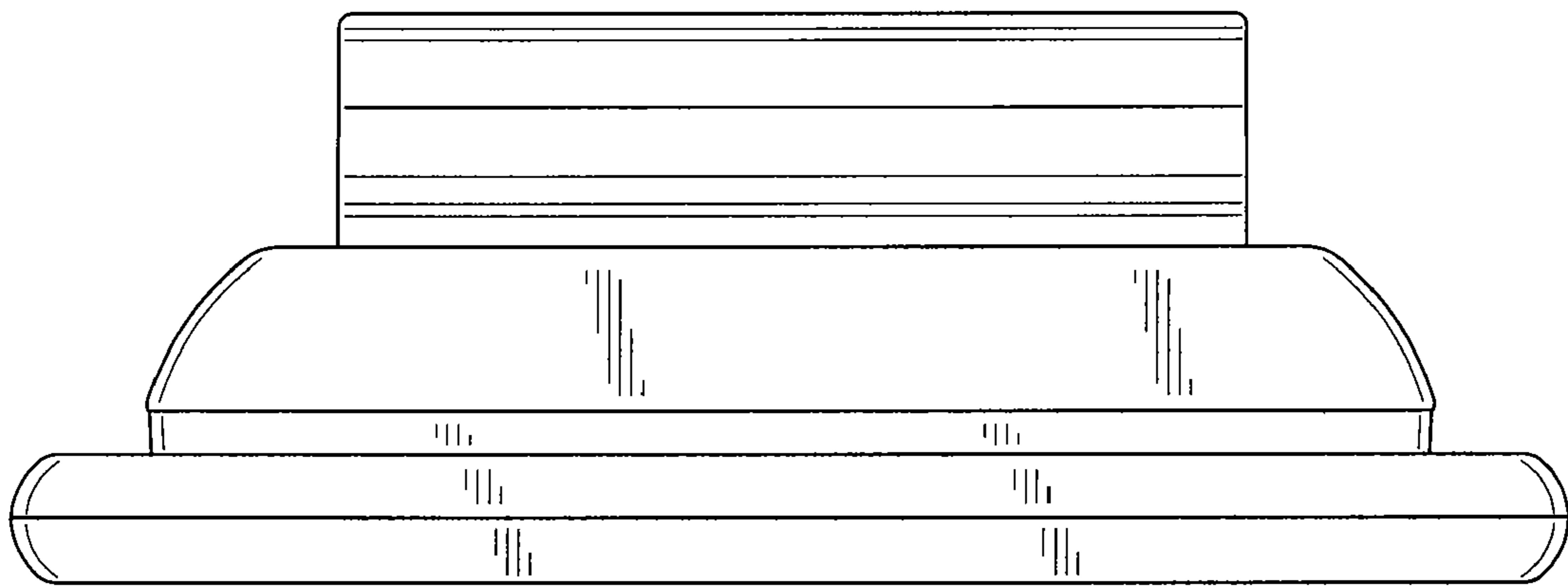

FIG.8

