

US00D676463S

(12) **United States Design Patent**
Ewringmann et al.

(10) **Patent No.:** **US D676,463 S**

(45) **Date of Patent:** **** Feb. 19, 2013**

(54) **ROAD CONSTRUCTION MACHINE**

D611,505 S * 3/2010 Loew et al. D15/20
D611,506 S * 3/2010 Loew et al. D15/20
D668,269 S * 10/2012 Tezuka et al. D15/20

(75) Inventors: **Ulrich Ewringmann**, Taufkirchen (DE);
Boris Eickhoff, Taufkirchen (DE)

OTHER PUBLICATIONS

(73) Assignee: **Hamm AG**, Tirschenreuth (DE)

Hamm AG, Hamm, www.hamm.eu/en/produkte/walzenzuege/index.php.
Hamm AG, Hamm, www.hamm.eu/en/produkte/tandemwalzen/index.php.
Hamm AG, Hamm, www.hamm.eu/en/produkte/statische-walzen/index.php.

(**) Term: **14 Years**

(21) Appl. No.: **29/430,962**

* cited by examiner

(22) Filed: **Aug. 31, 2012**

(30) **Foreign Application Priority Data**

Primary Examiner — Mark Goodwin

Mar. 15, 2012 (EP) 002009308-01-05

(74) *Attorney, Agent, or Firm* — Maier & Maier PLLC

(51) **LOC (9) Cl.** **15-03**

(57) **CLAIM**

(52) **U.S. Cl.** **D15/20; D15/22**

The ornamental design for a road construction machine, as shown and described.

(58) **Field of Classification Search** D15/10,
D15/20, 22-28, 33; D12/14; 180/20, 89.12;
404/122-125, 117, 128, 132, 90; 280/104,
280/124.111; 73/82, 84, 78, 573

DESCRIPTION

See application file for complete search history.

FIG. 1 is a front left perspective view of a road construction machine, showing our design;
FIG. 2 is a rear right perspective view thereof;
FIG. 3 is a front view thereof;
FIG. 4 is a rear view thereof;
FIG. 5 is a left side view thereof;
FIG. 6 is a right side view thereof; and,
FIG. 7 is a top view thereof.

(56) **References Cited**

U.S. PATENT DOCUMENTS

D207,532 S * 5/1967 Garis et al. D15/20
D208,694 S * 9/1967 Harbke D15/20
D275,678 S * 9/1984 Mawhorr et al. D15/20
D396,431 S * 7/1998 Lindgren et al. D12/14
D500,329 S * 12/2004 Bauve et al. D15/28
D516,094 S * 2/2006 Dotsch et al. D15/20
D589,067 S * 3/2009 Yamamoto D15/28
D592,682 S * 5/2009 Haubrich et al. D15/20
D607,473 S * 1/2010 Haubrich et al. D15/20

The bottom of the road construction machine is not seen during ordinary use and forms no part of the claimed design. The broken line showing of parts of the drawings is included for the purpose of illustrating portions of the road construction machine and forms no part of the claimed design.

1 Claim, 7 Drawing Sheets

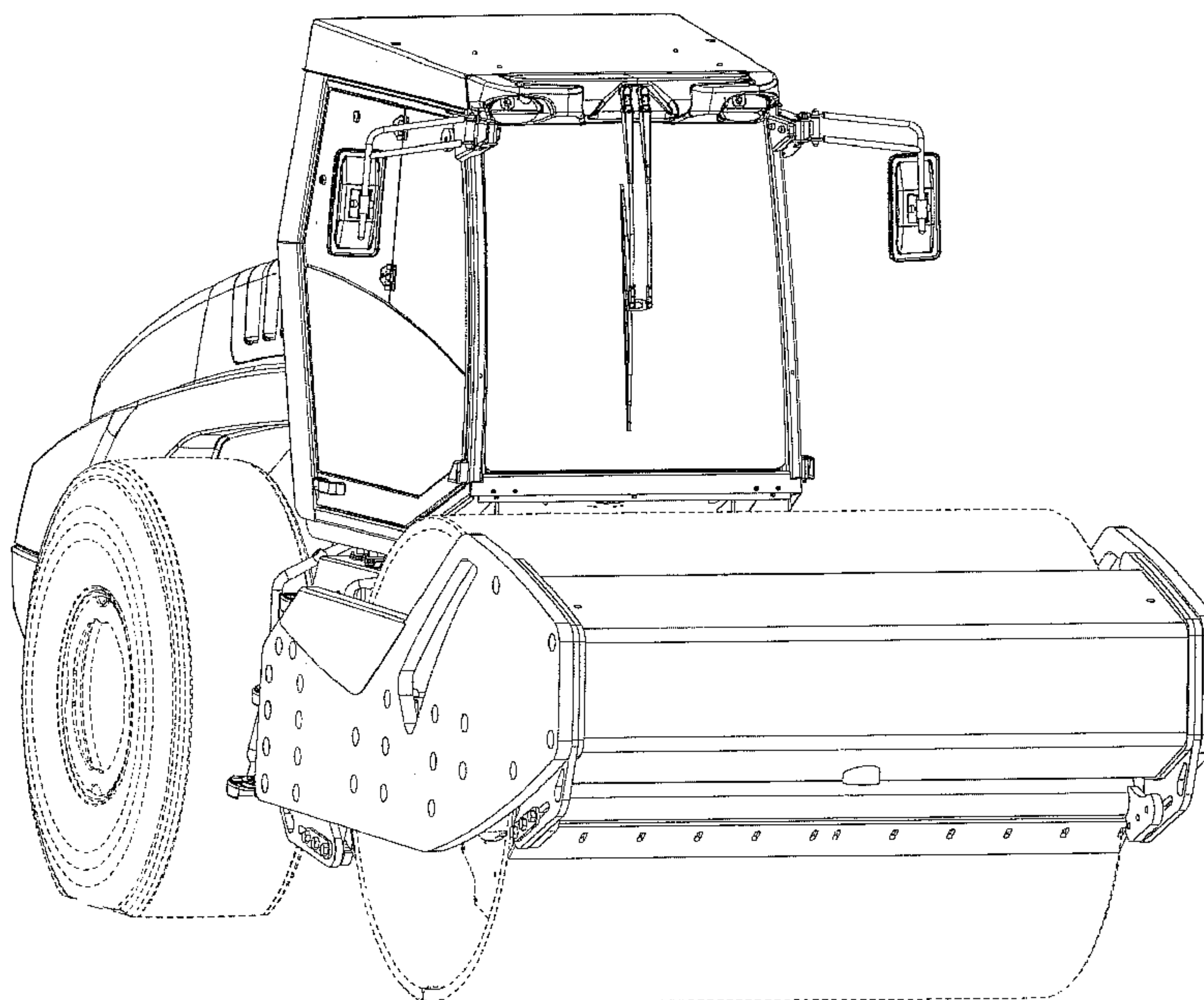

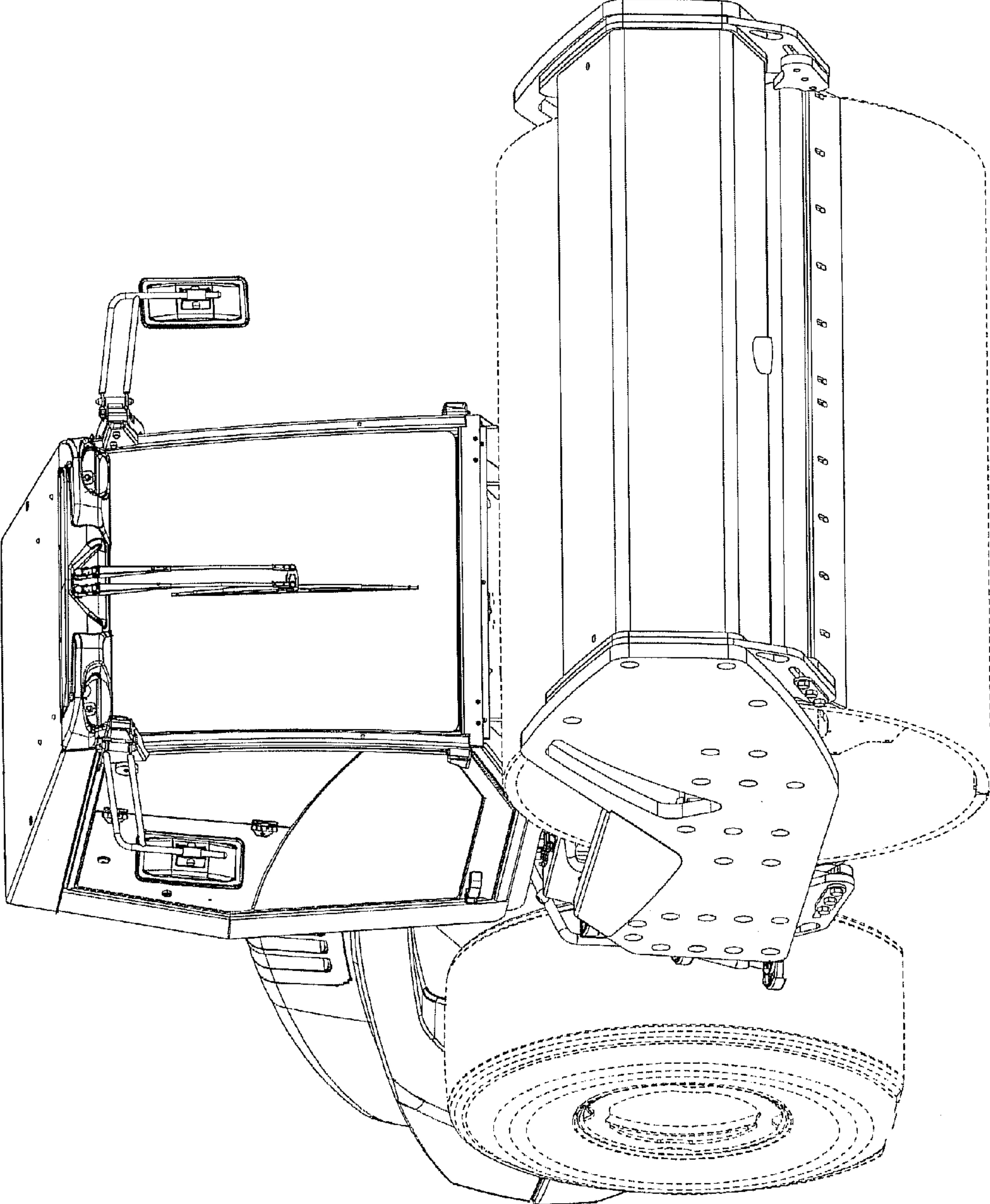

Fig. 1

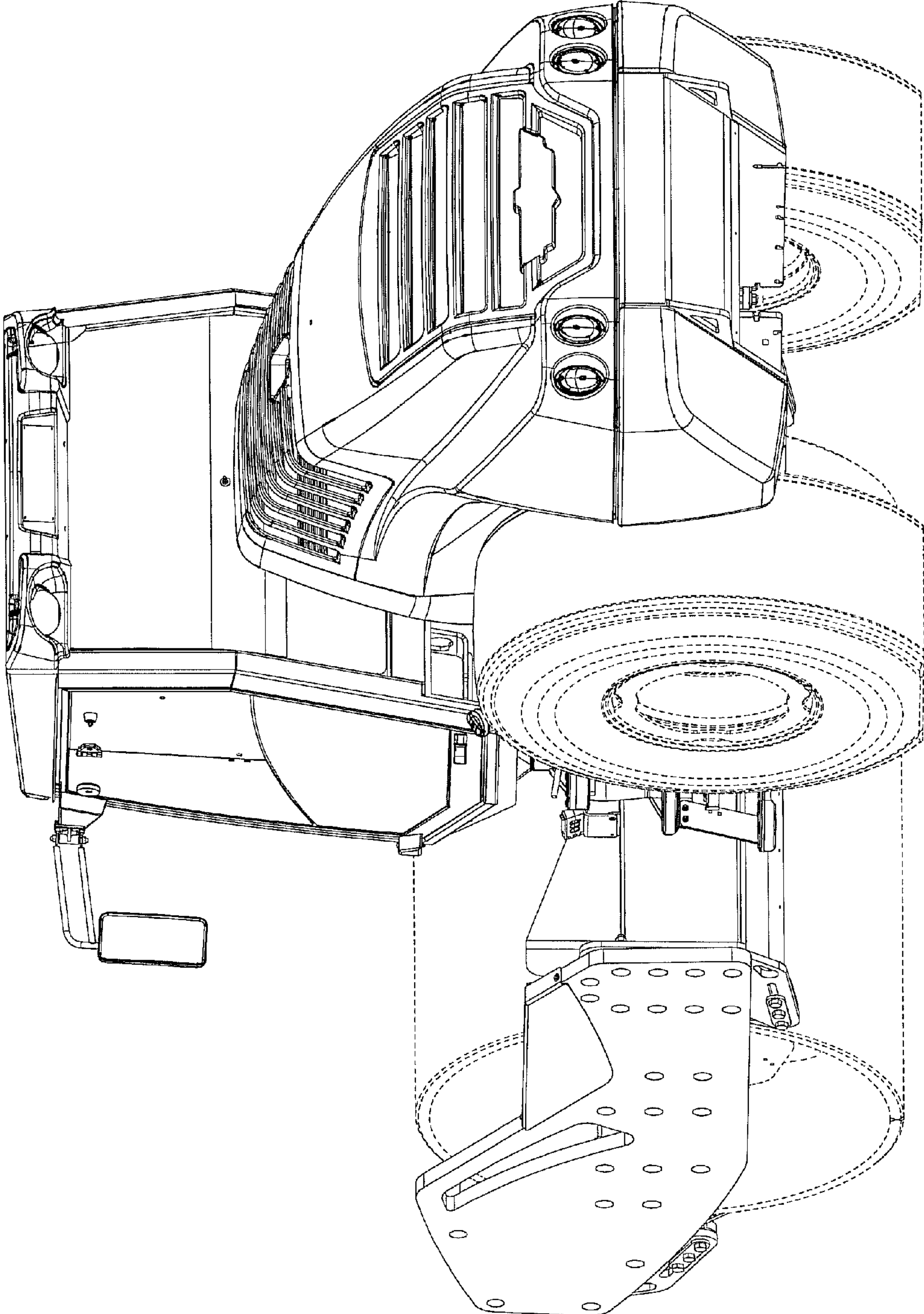

Fig. 2

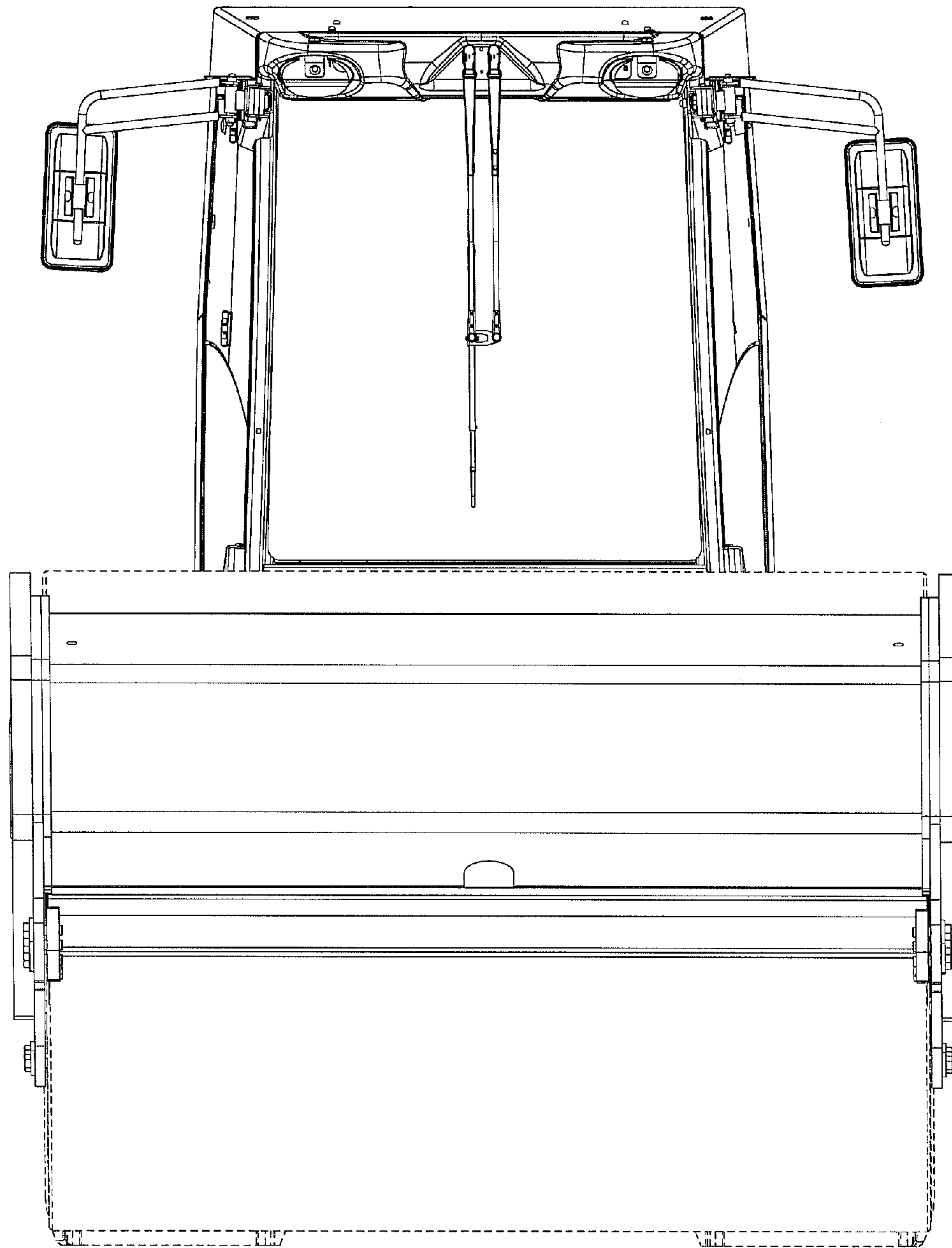

Fig. 3

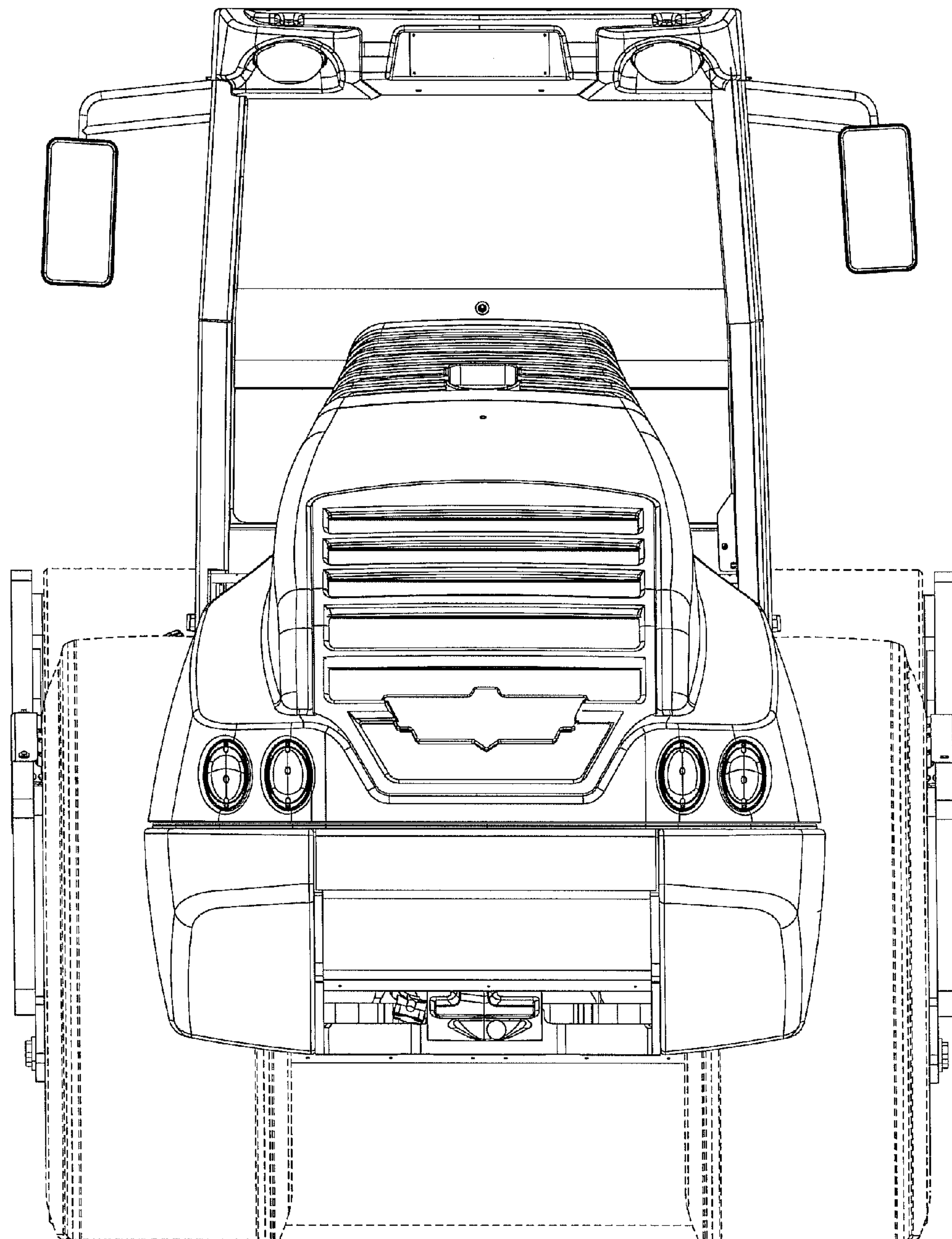

Fig. 4

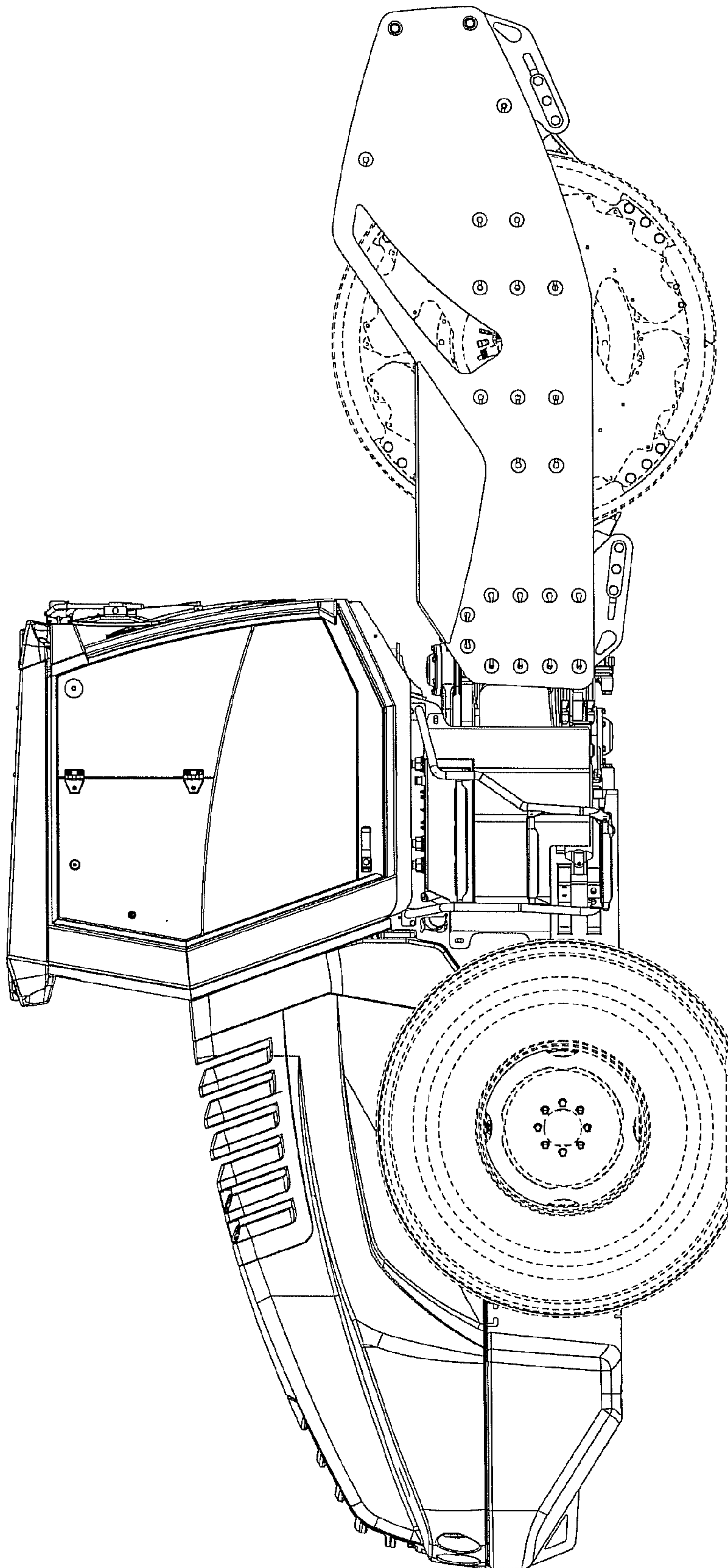

Fig. 5

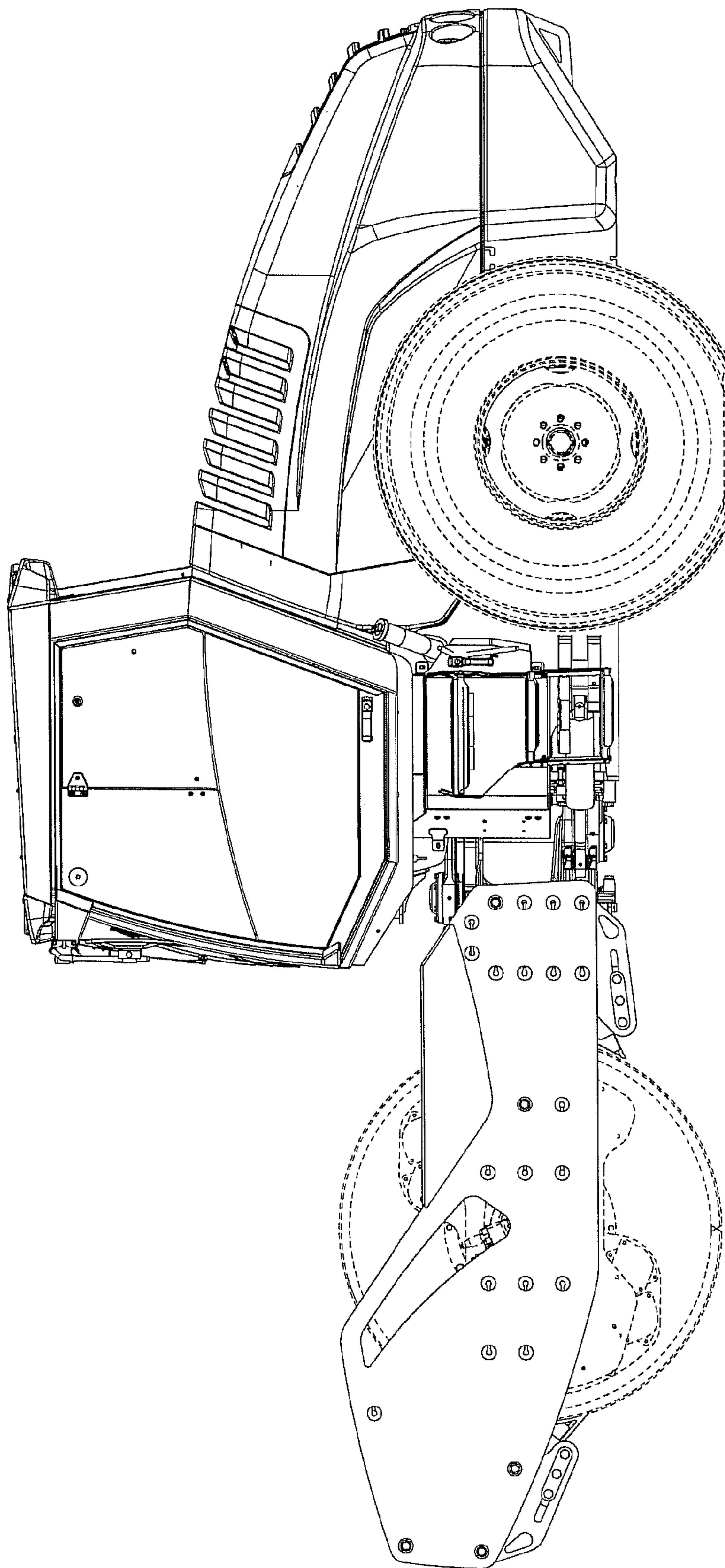

Fig. 6

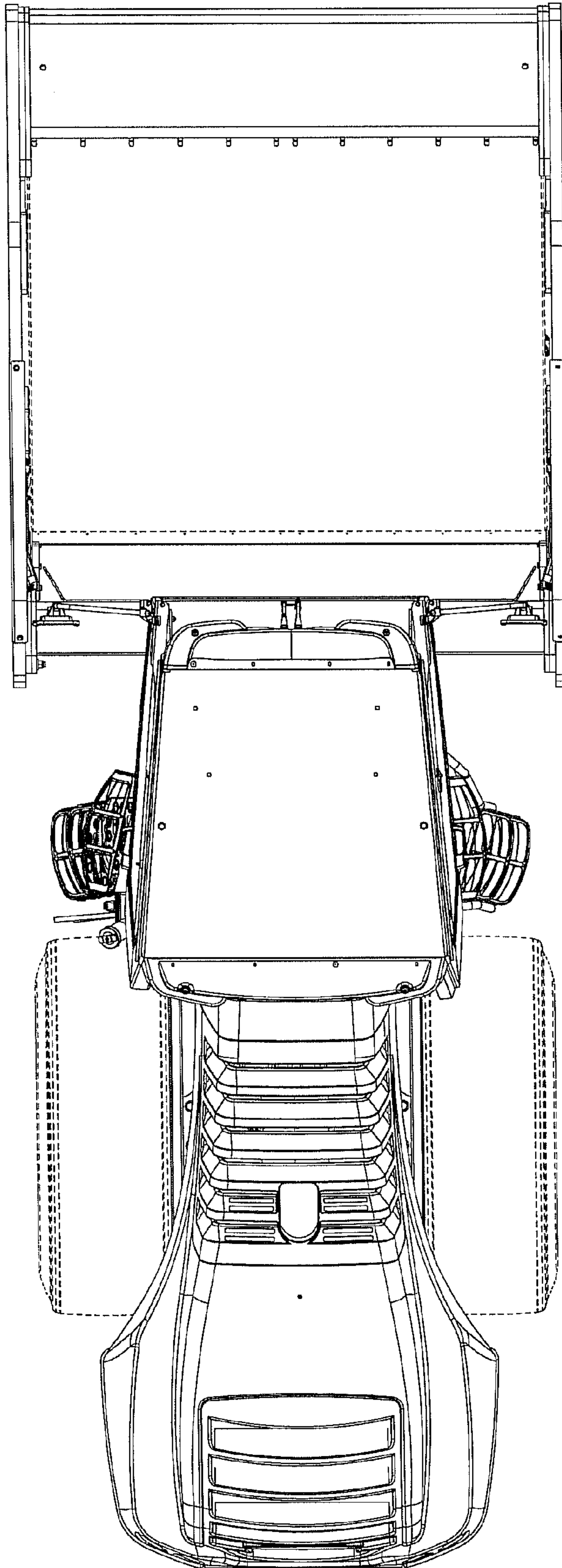

Fig. 7