



US00D675760S

(12) **United States Design Patent**
Schneider

(10) **Patent No.:** **US D675,760 S**
(45) **Date of Patent:** **** Feb. 5, 2013**

(54) **HEADLIGHT FOR A VEHICLE**

(75) Inventor: **Alexander Schneider**, Munich (DE)

(73) Assignee: **Bayerische Motoren Werke Aktiengesellschaft**, Munich (DE)

(**) Term: **14 Years**

(21) Appl. No.: **29/425,076**

(22) Filed: **Jun. 20, 2012**

Related U.S. Application Data

(62) Division of application No. 29/347,799, filed on Jun. 7, 2010, now Pat. No. Des. 667,973.

(30) **Foreign Application Priority Data**

Dec. 8, 2009 (DE) 402009006098

(51) **LOC (9) Cl.** **26-06**

(52) **U.S. Cl.** **D26/28**

(58) **Field of Classification Search** D26/28-36;
362/459-468, 475-478, 485-487

See application file for complete search history.

(56) **References Cited**

U.S. PATENT DOCUMENTS

D528,681 S *	9/2006	Nakahara	D26/28
D528,685 S *	9/2006	Yoshida	D26/28
D540,714 S	4/2007	Mueller-Stolz		
D544,114 S *	6/2007	Ohta	D26/28
D544,614 S *	6/2007	Markefka	D26/28
D549,857 S *	8/2007	Lin	D26/28
D556,349 S	11/2007	Golden et al.		
D560,291 S	1/2008	Koyama		
D561,358 S *	2/2008	Tachibana	D26/28
D634,867 S	3/2011	Frenzel et al.		

FOREIGN PATENT DOCUMENTS

EM 000482419-0001 10/2006

OTHER PUBLICATIONS

Mini Cooper, BMW Group PressClub: www.press.bmwgroup.com, P0029247, Oct. 2006.

Mini Cooper, BMW Group PressClub: www.press.bmwgroup.com, P0029227, Oct. 2006.

* cited by examiner

Primary Examiner — Marcus Jackson

(74) *Attorney, Agent, or Firm* — Crowell & Moring LLP

(57) **CLAIM**

The ornamental design for a headlight for a vehicle, as shown and described.

DESCRIPTION

This application contains subject matter related to application Ser. No. 29/347,801, filed Jun. 7, 2010, issued Mar. 1, 2011 as U.S. Pat. No. D633,571, and entitled "Vehicle, Toy, and/or Replicas Thereof."

FIG. 1 is a left perspective view of a first embodiment of a headlight for a vehicle according to my design;

FIG. 2 is a left side view thereof;

FIG. 3 is a right side view thereof;

FIG. 4 is a front view thereof; and

FIG. 5 is a top view thereof.

FIG. 6 is a right perspective view of a second embodiment of the headlight for a vehicle according to my design, with the headlight for a vehicle for the opposite side of the vehicle being depicted in the first embodiment:

FIG. 7 is a right side view thereof;

FIG. 8 is a left side view thereof;

FIG. 9 is a front view thereof; and,

FIG. 10 is a top view thereof.

The broken lines are for illustrative purposes only and form no part of the claimed design.

1 Claim, 6 Drawing Sheets

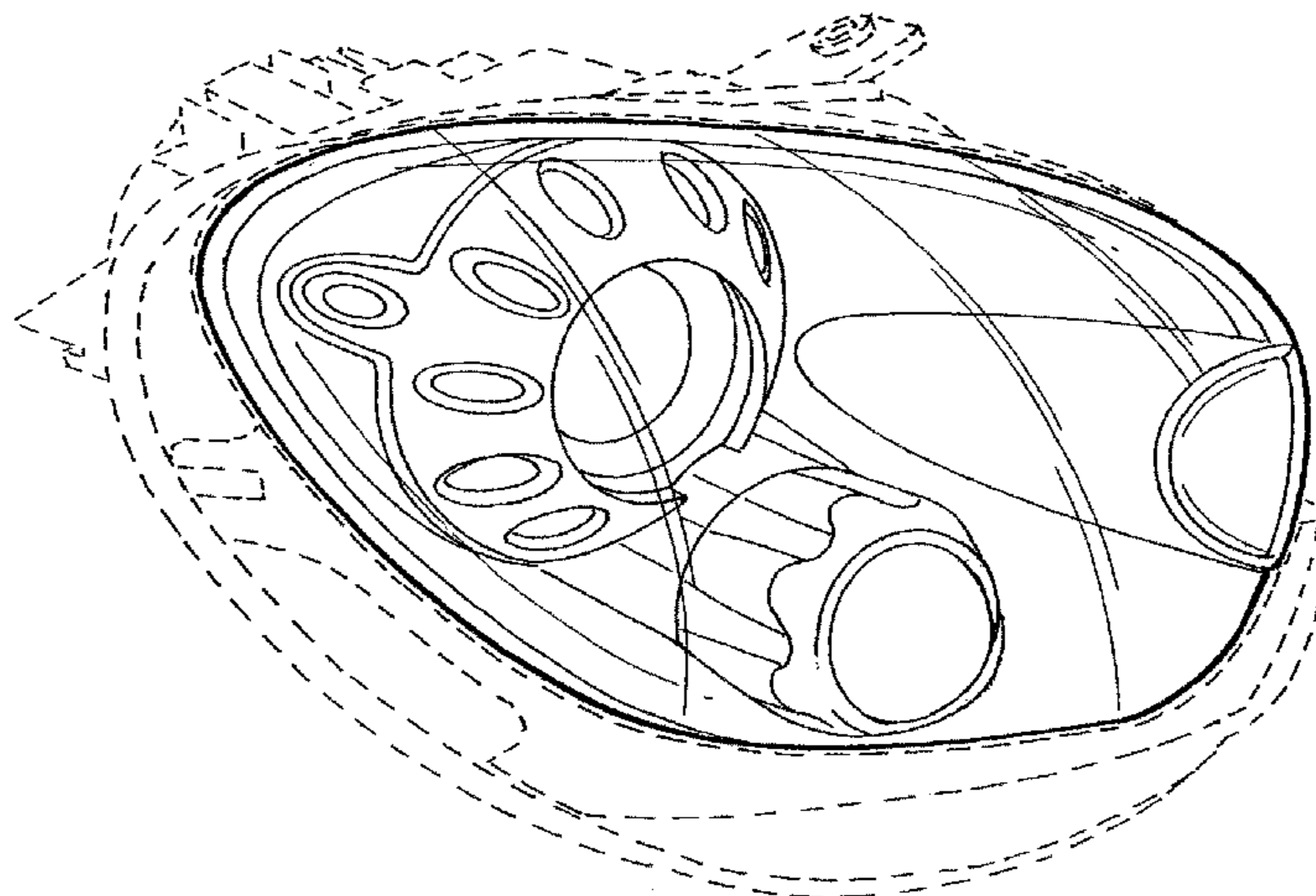

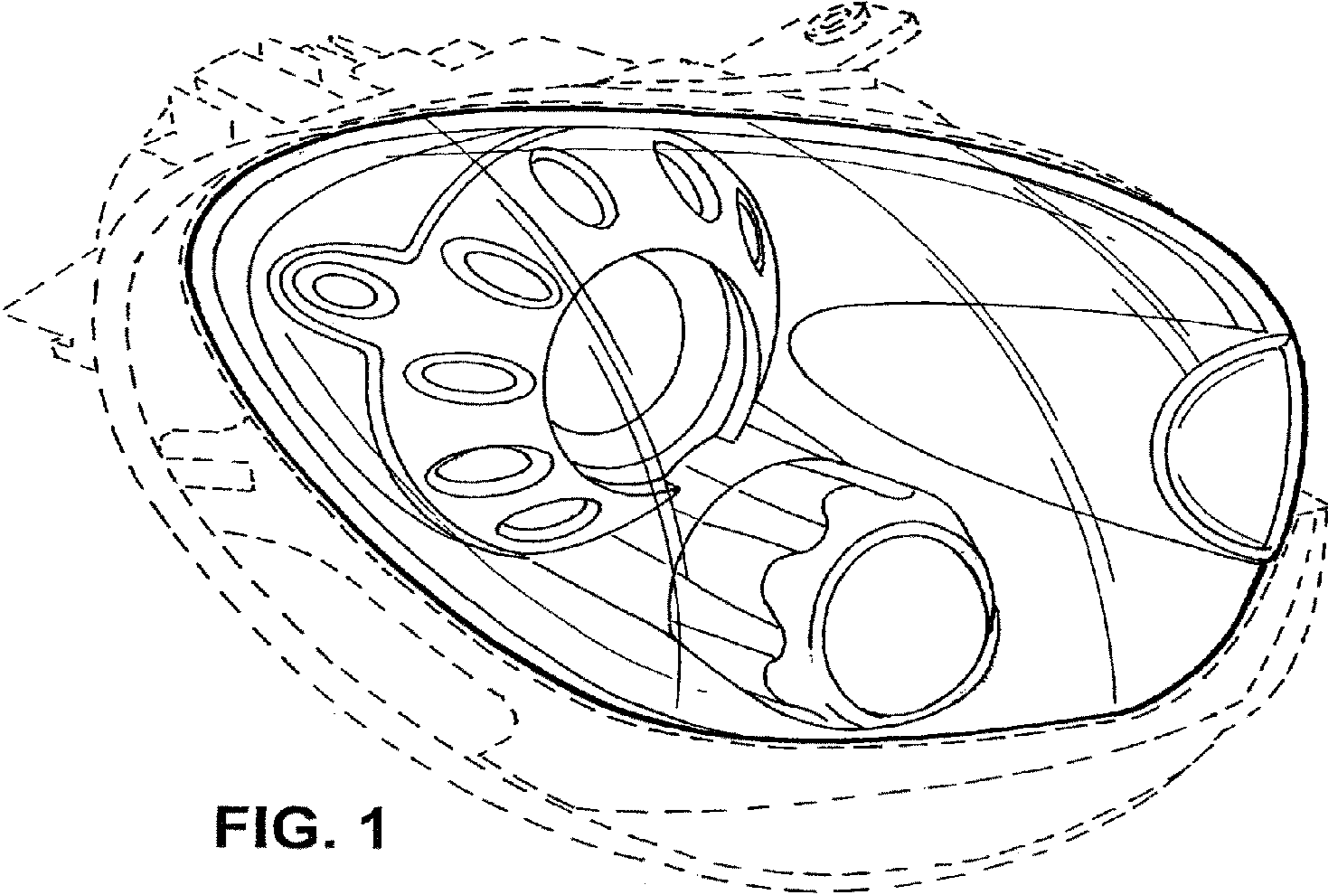

FIG. 1

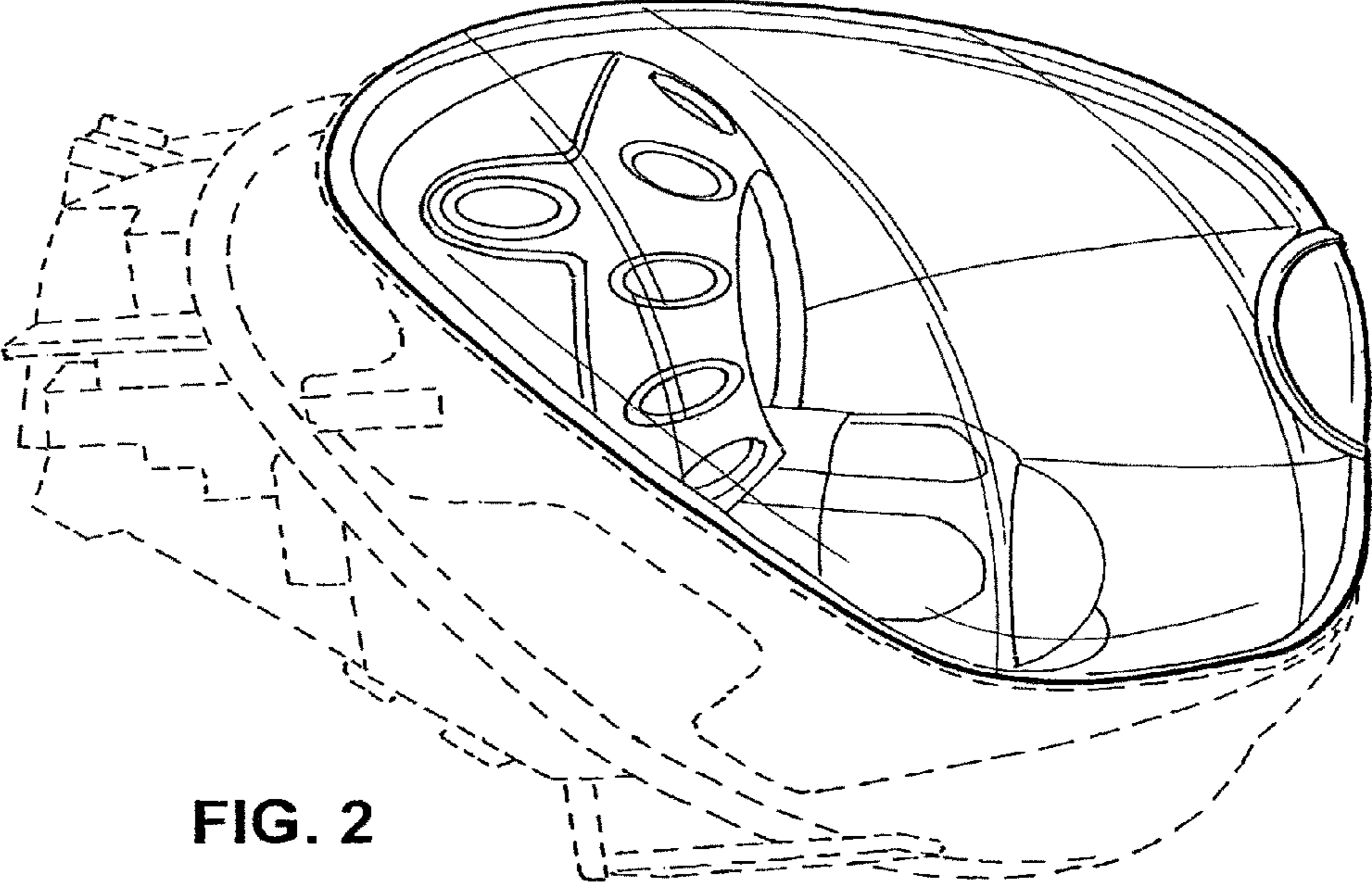
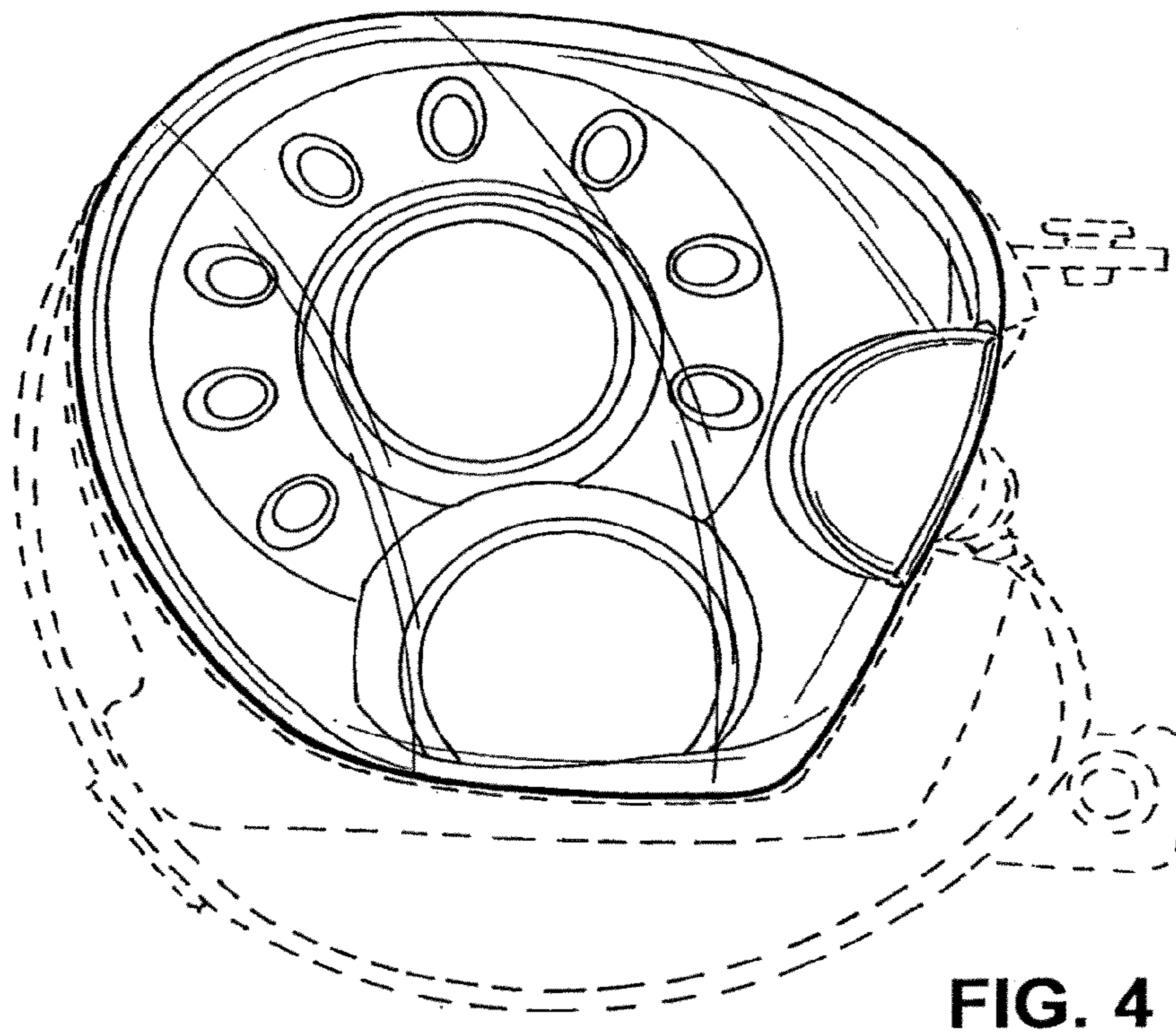
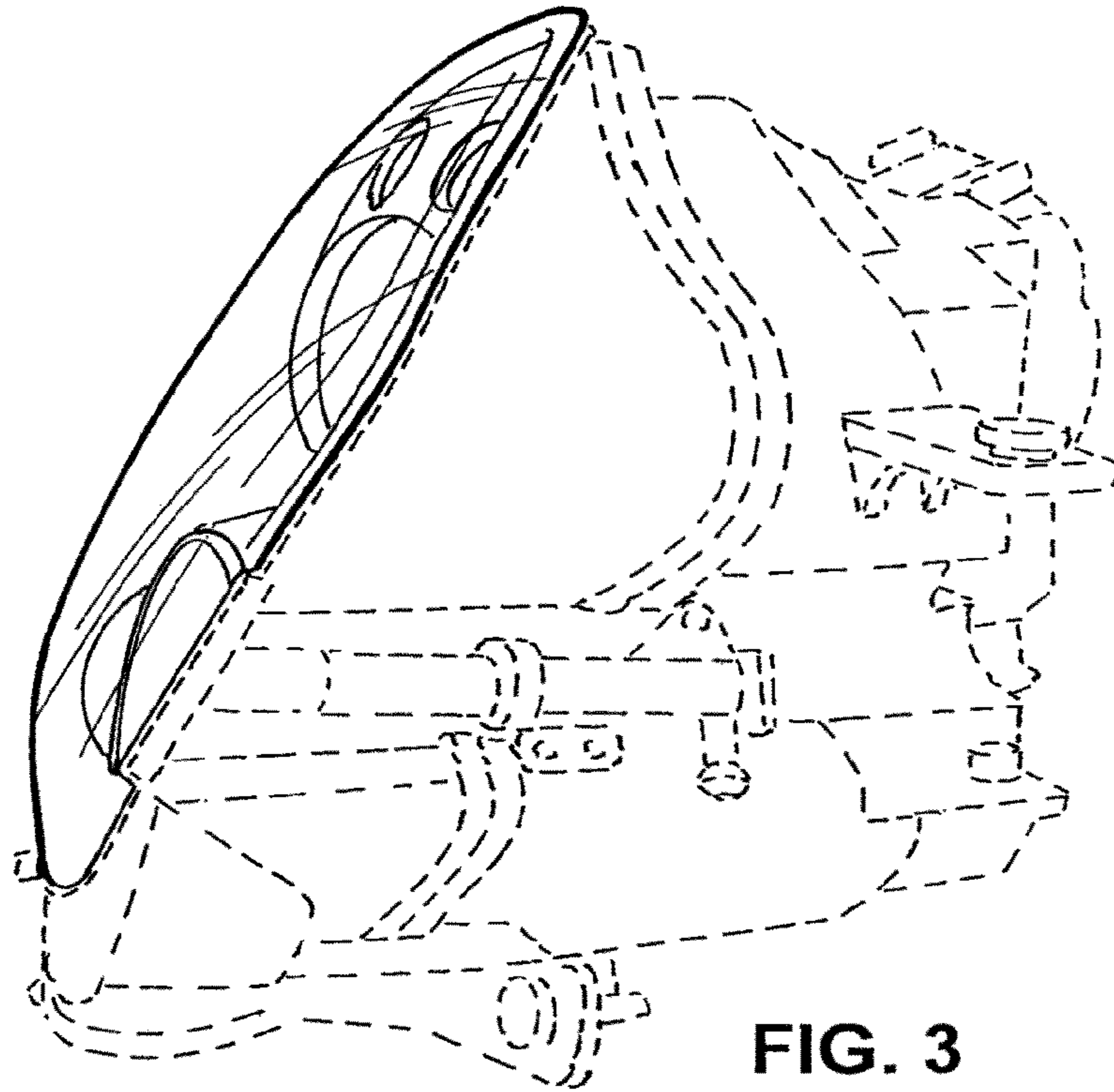

FIG. 2



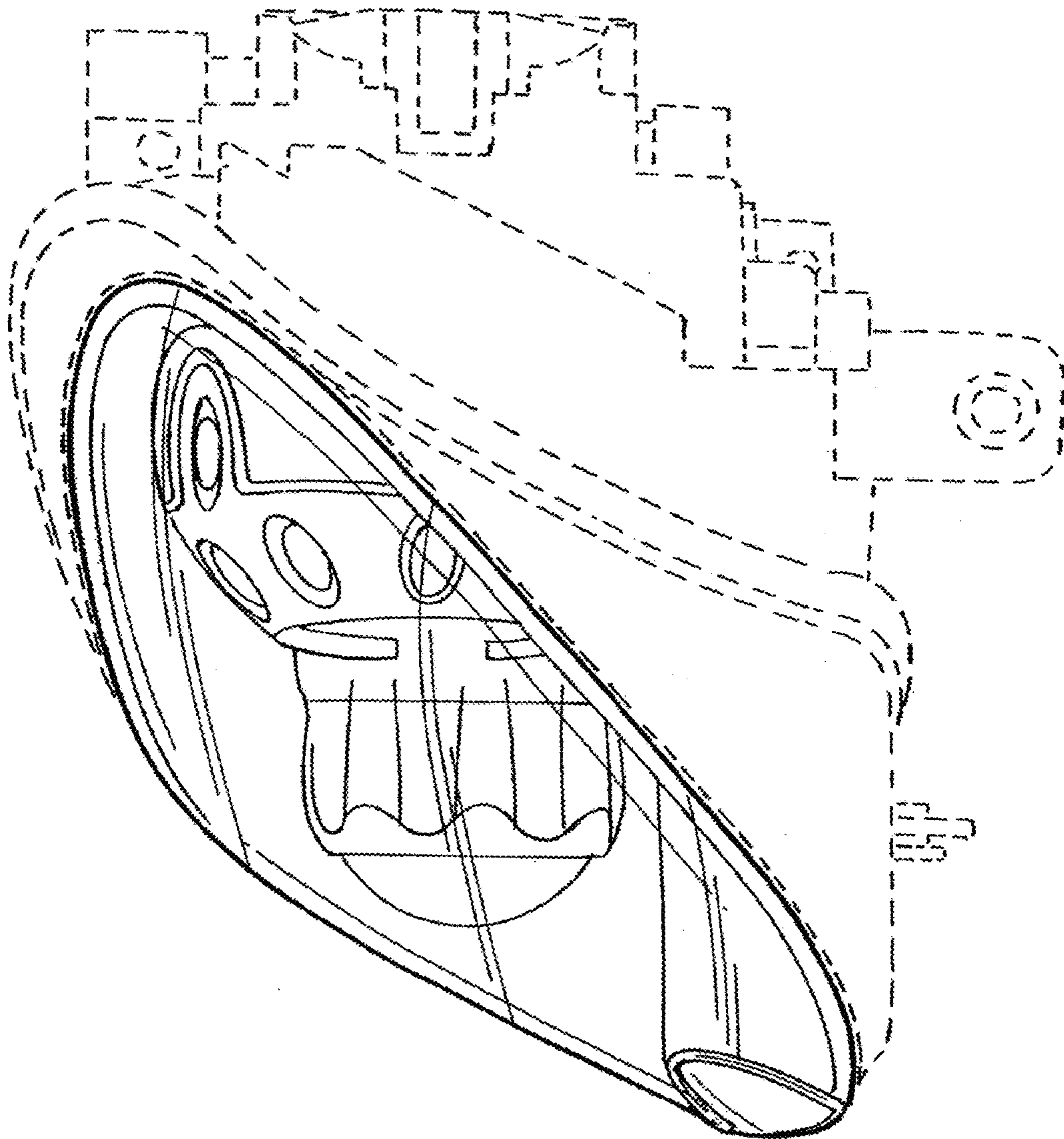

FIG. 5

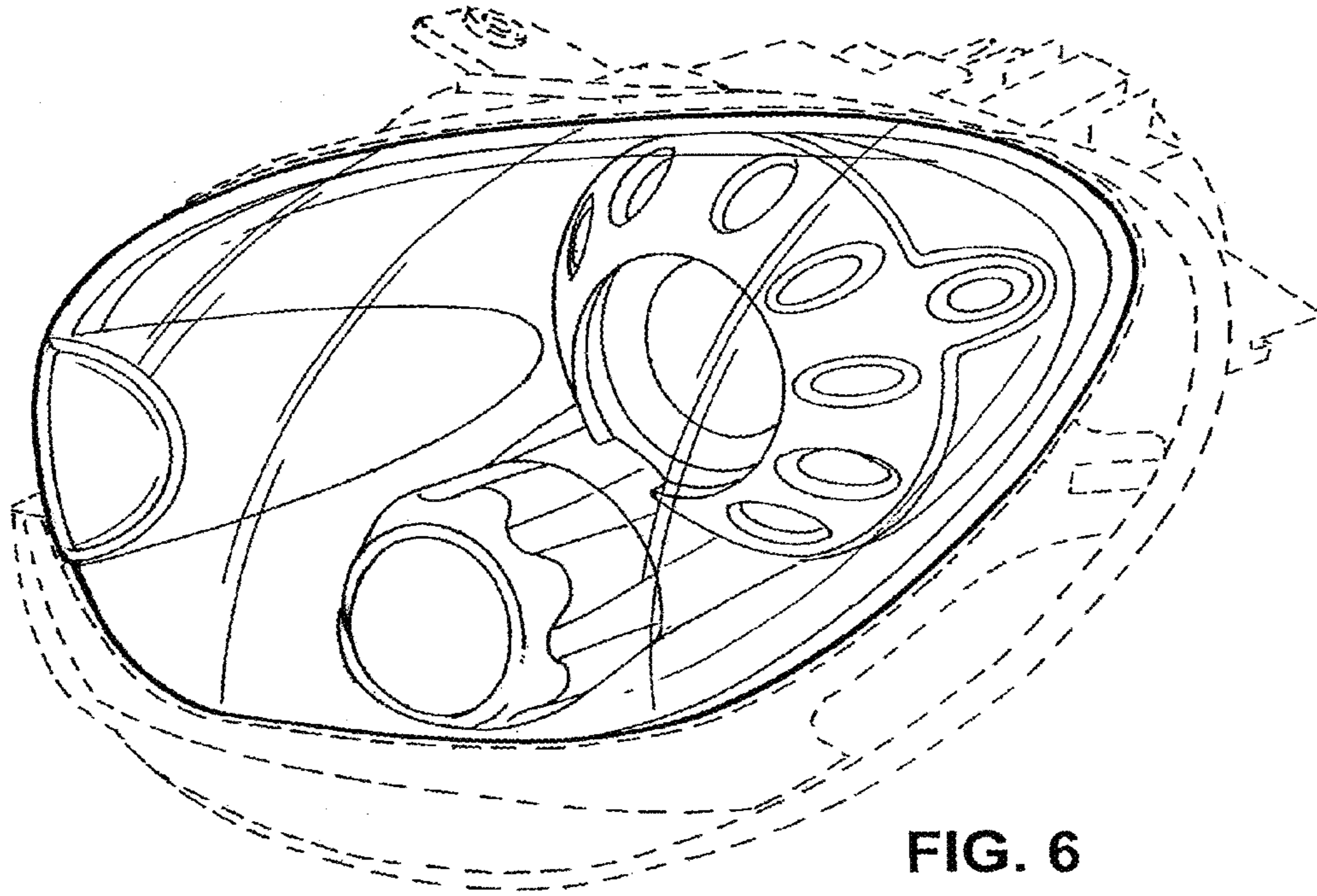

FIG. 6

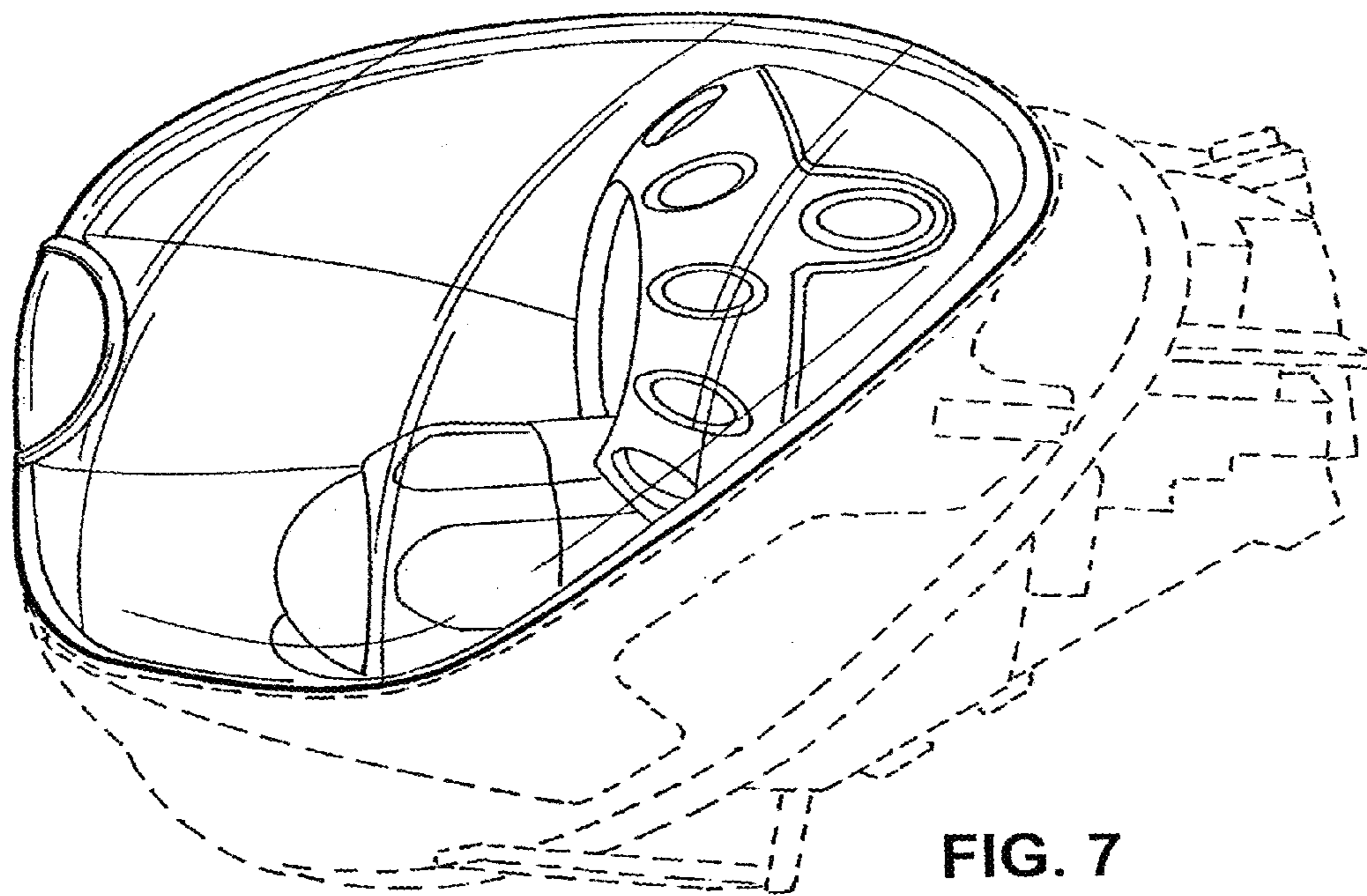

FIG. 7

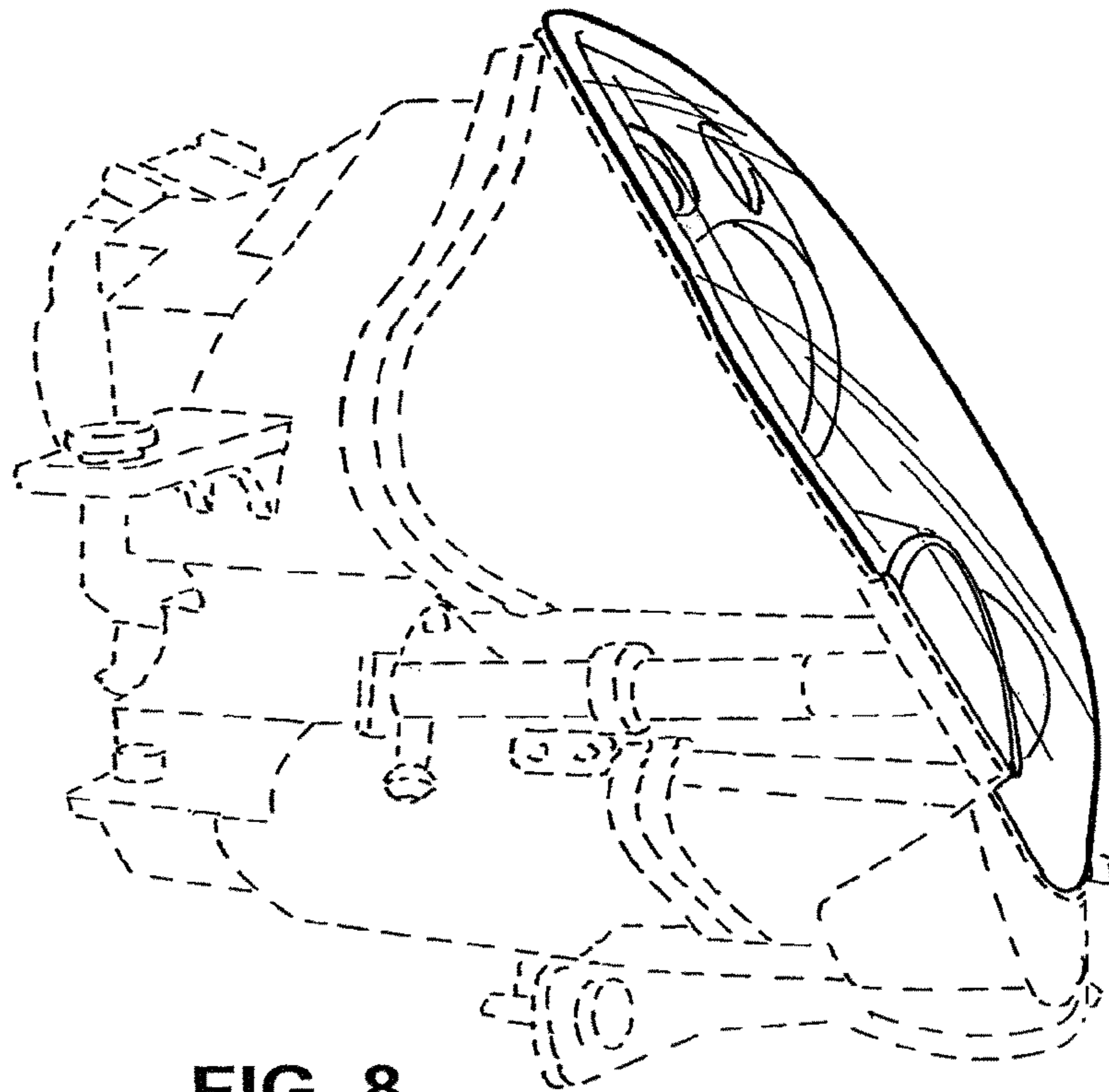

FIG. 8

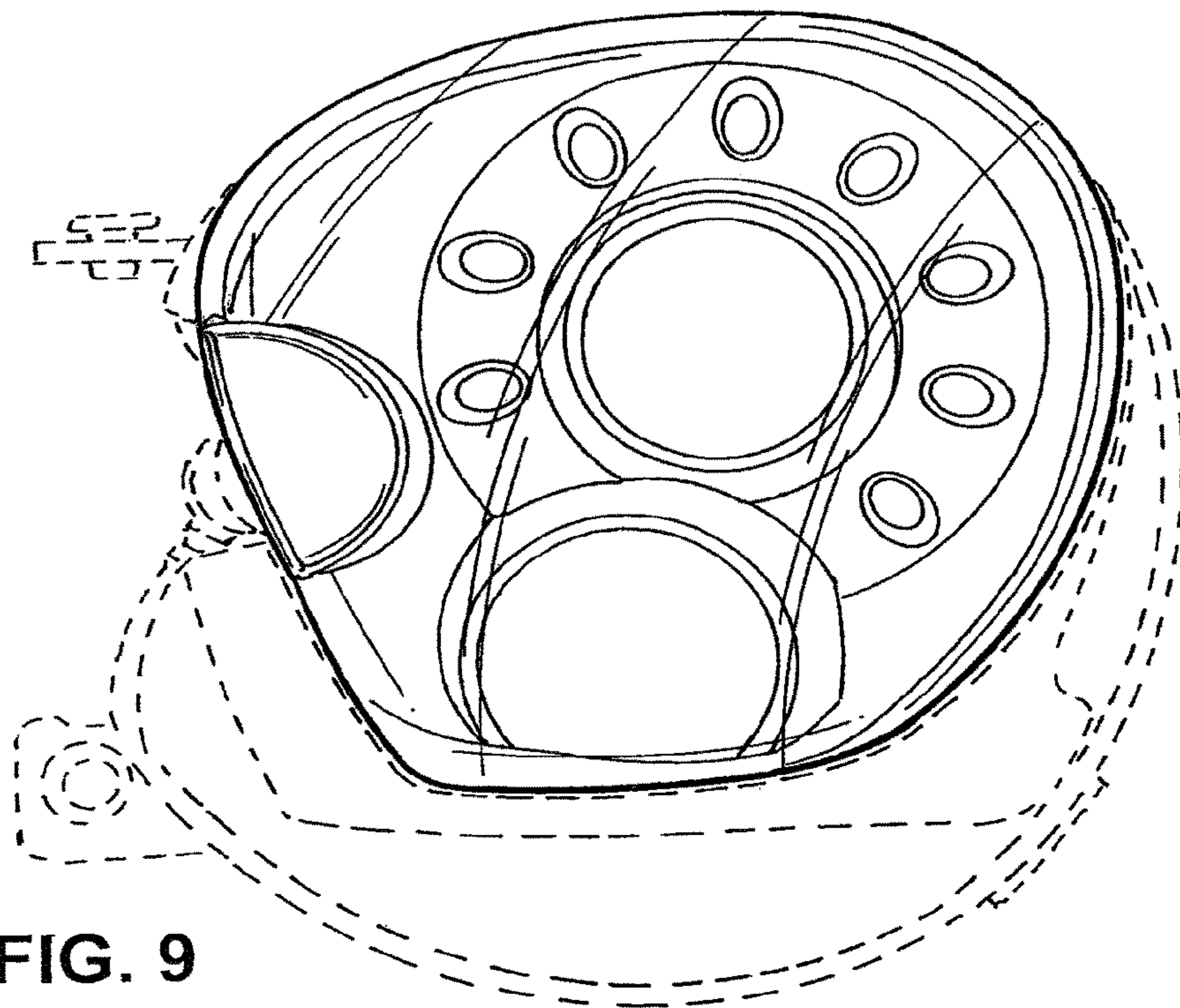

FIG. 9

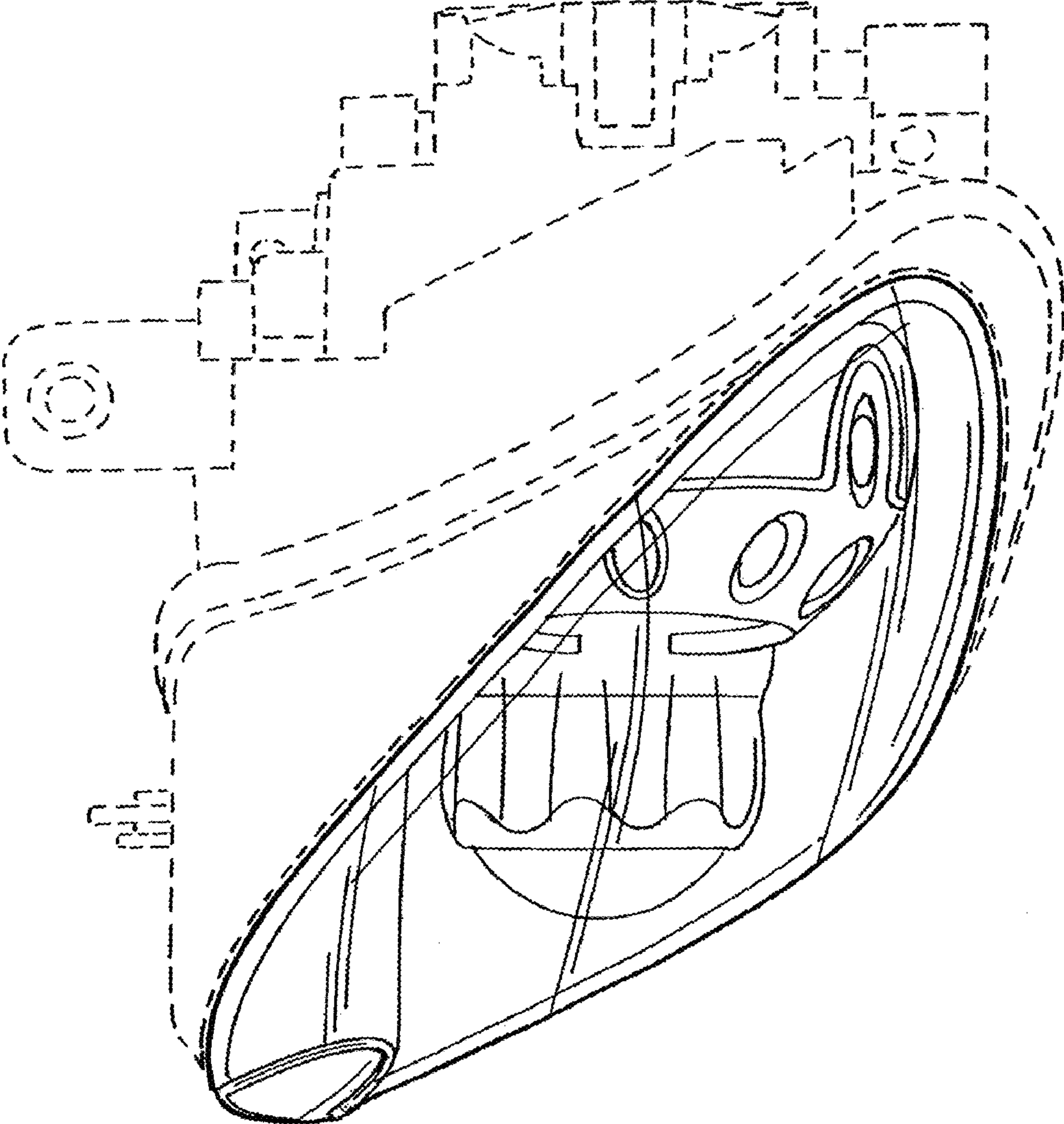

FIG. 10