



US00D675557S

(12) **United States Design Patent**
Harris

(10) **Patent No.:** **US D675,557 S**
(45) **Date of Patent:** **** Feb. 5, 2013**

(54) **MOTORCYCLE BAG**

DESCRIPTION

- (75) Inventor: **Solomon J. Harris**, Eugene, OR (US)
- (73) Assignee: **Cutting Edge Illusions, Inc.**, Eugene, OR (US)
- (**) Term: **14 Years**
- (21) Appl. No.: **29/407,740**
- (22) Filed: **Dec. 1, 2011**
- (51) **LOC (9) Cl.** **12-11**
- (52) **U.S. Cl.** **D12/410**
- (58) **Field of Classification Search** D12/409, D12/410, 110; 180/219, 220; 224/42.11, 224/412-435; 296/37.1; 280/304.5, 288.4
See application file for complete search history.

(56) **References Cited**

U.S. PATENT DOCUMENTS

D506,968 S *	7/2005	Berardino et al.	D12/410
D550,146 S *	9/2007	Hanagan	D12/410
D585,358 S *	1/2009	Hanagan et al.	D12/410
7,793,747 B2 *	9/2010	Brown	224/423

* cited by examiner

Primary Examiner — Susan M Lee
Assistant Examiner — Linda G. Brooks
 (74) *Attorney, Agent, or Firm* — Zeman-Mullen & Ford, LLP

(57) **CLAIM**

The ornamental design for a motorcycle bag, as shown and described.

FIG. 1 is a perspective view of my new design for a motorcycle bag, shown in position of use on the left side of a rear wheel of a motorcycle. The lid of the motorcycle bag, the cutout for a motorcycle exhaust pipe, and the other structure shown in broken lines form no part of the claimed design.

FIG. 2 is front view of the motorcycle bag. The broken lines at bottom left represent an unclaimed cutout for an exhaust pipe, as shown and described in FIG. 1. The other broken lines represent an unclaimed cutout for a motorcycle frame member.

FIG. 3 is a left side view of the motorcycle bag. The broken lines therein form no part of the claimed design.

FIG. 4 is a right side view of the motorcycle bag. Except for the broken lines that are parallel to the solid line exterior edge of the motorcycle bag, the broken lines in FIG. 4 form no part of the claimed design. The broken lines in FIG. 4 that are parallel to the solid line exterior edge of the motorcycle bag are boundary lines that also form no part of the claimed design, and that further encompass an area that forms no part of the claimed design.

FIG. 5 is a rear view of the motorcycle bag. The broken lines therein form no part of the claimed design; and,

FIGS. 6 and 7 are top and bottom views of the motorcycle bag, respectively. The broken lines therein represent the unclaimed motorcycle frame member cutout, the unclaimed lid, the unclaimed exhaust pipe cutout, and other unclaimed structure.

The characteristic feature of the design resides in the motorcycle bag's distinctive shape, including the sweeping indentation terminating at the pointed rear of the bag.

1 Claim, 4 Drawing Sheets

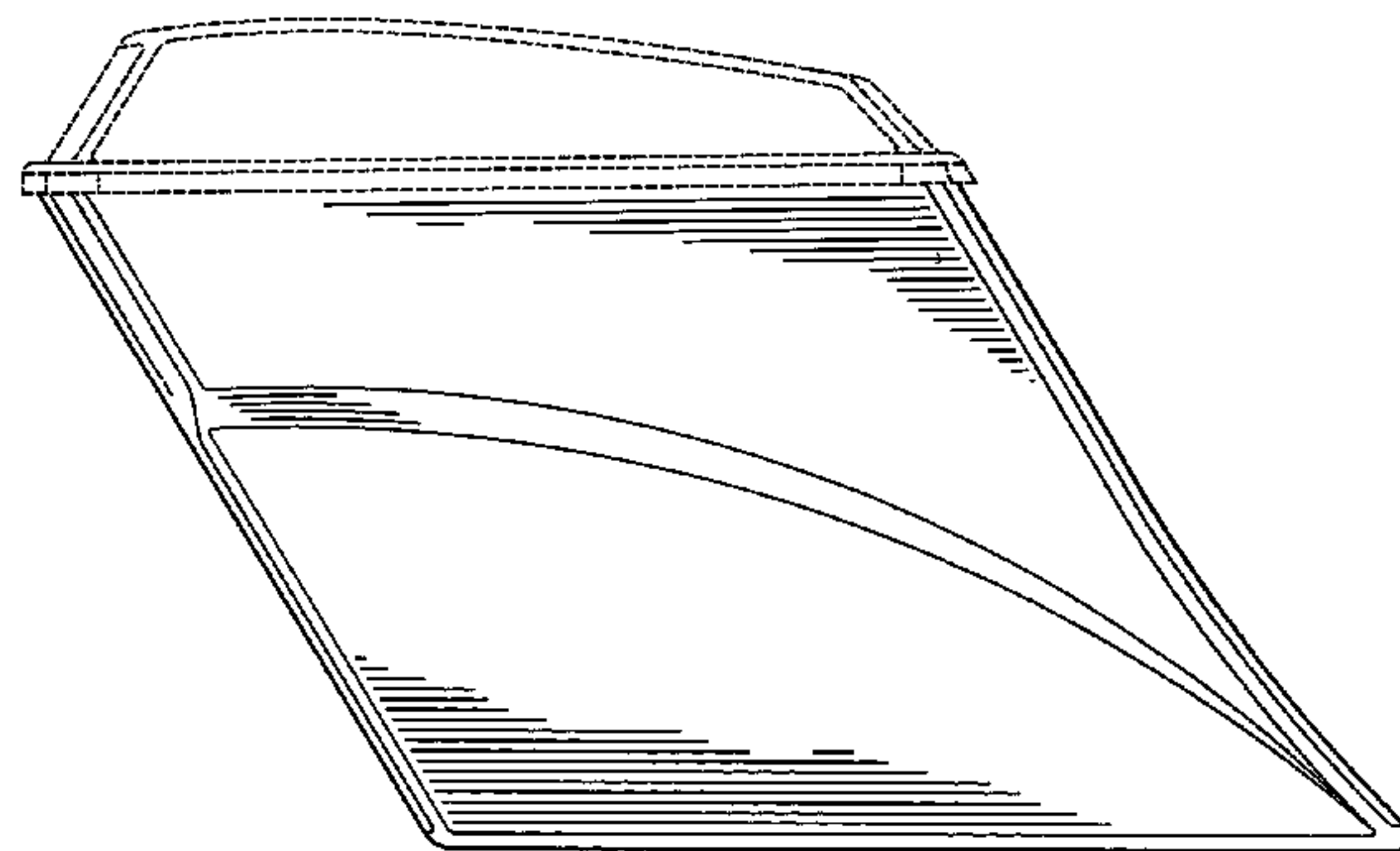
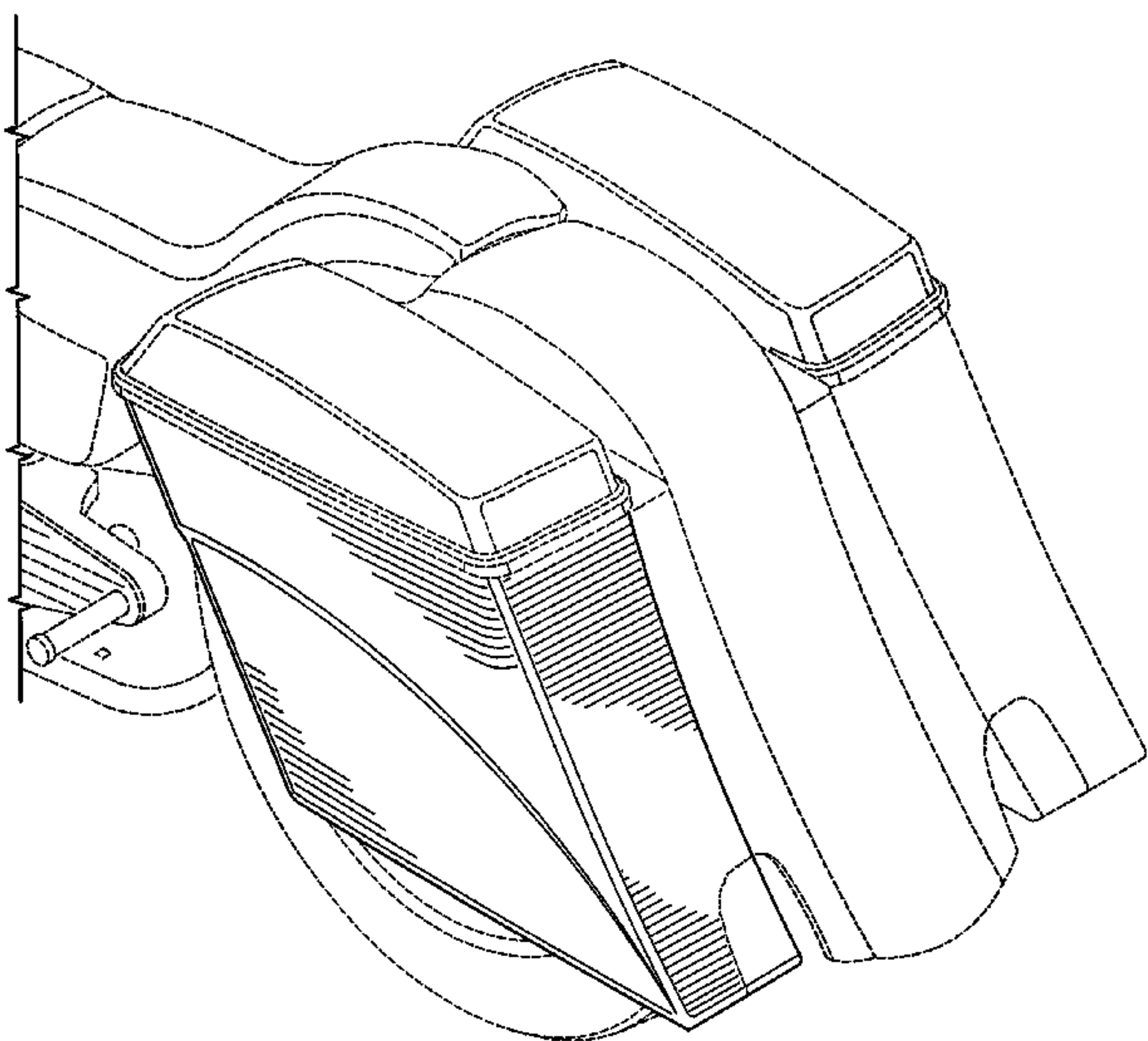

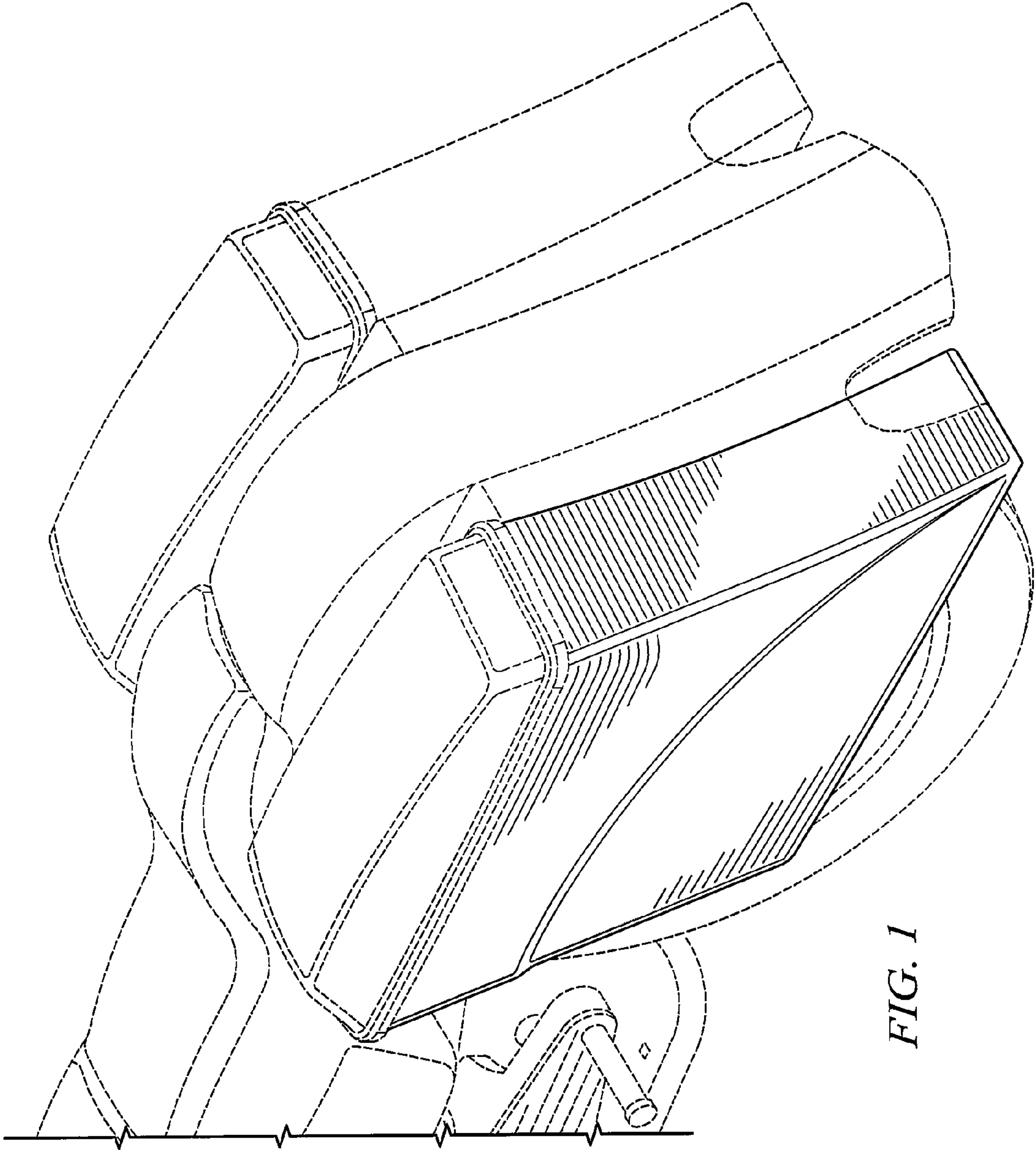

FIG. 1

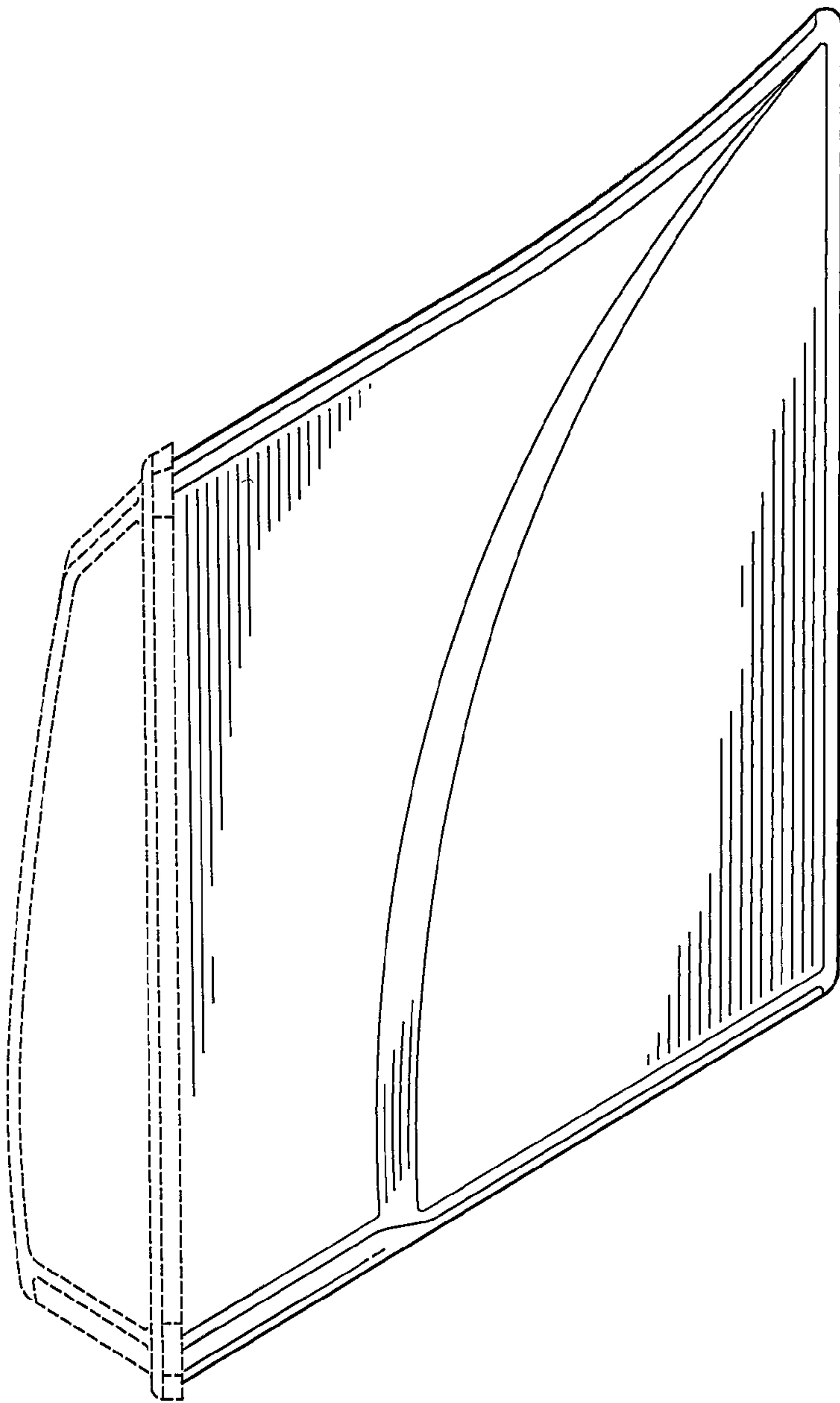

FIG. 3

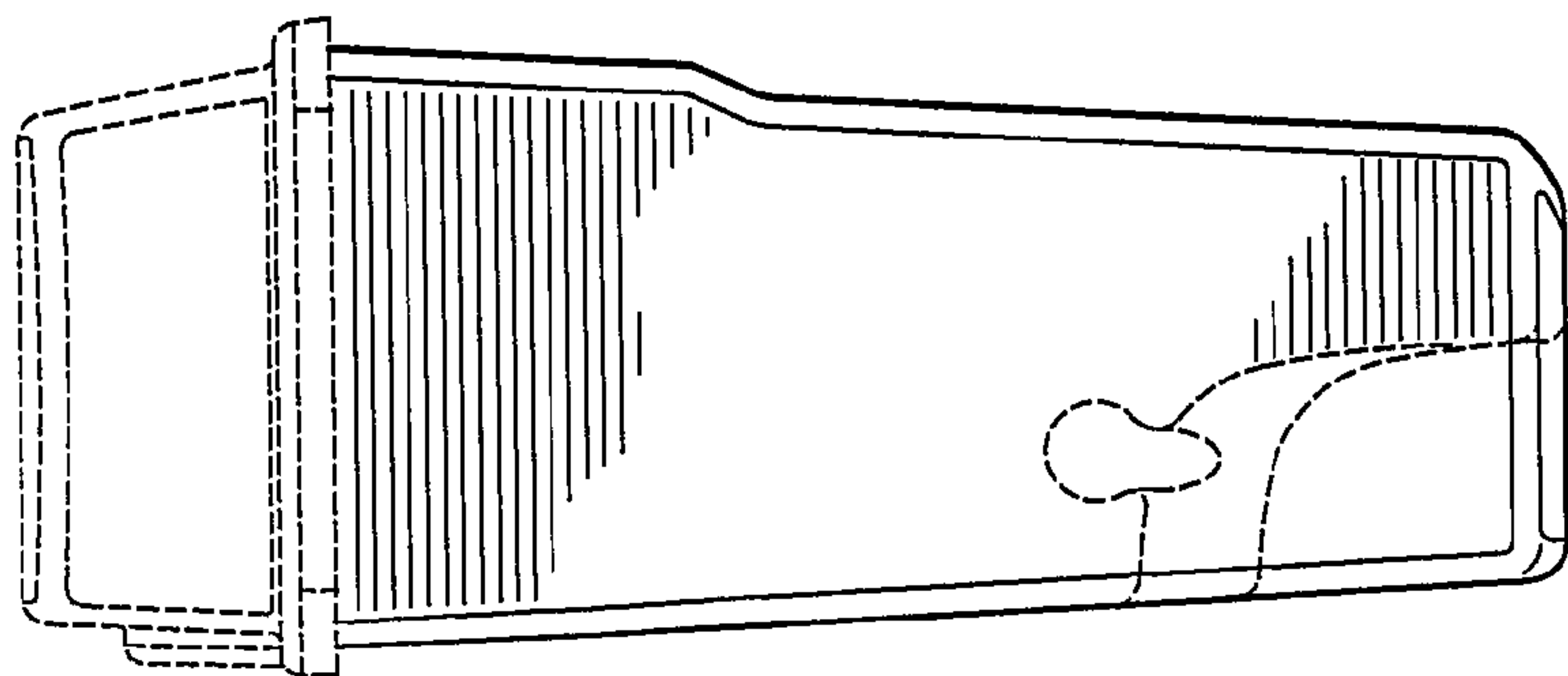

FIG. 2

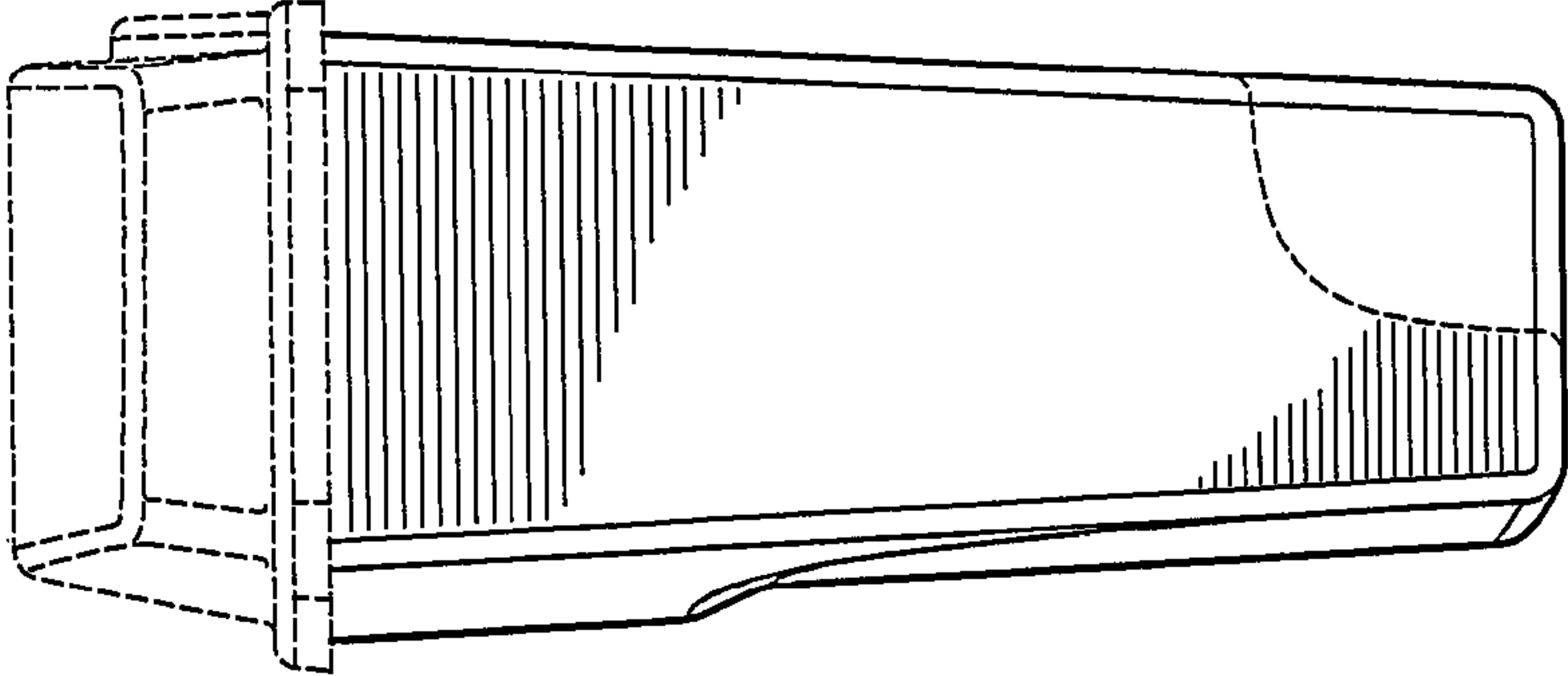

FIG. 5

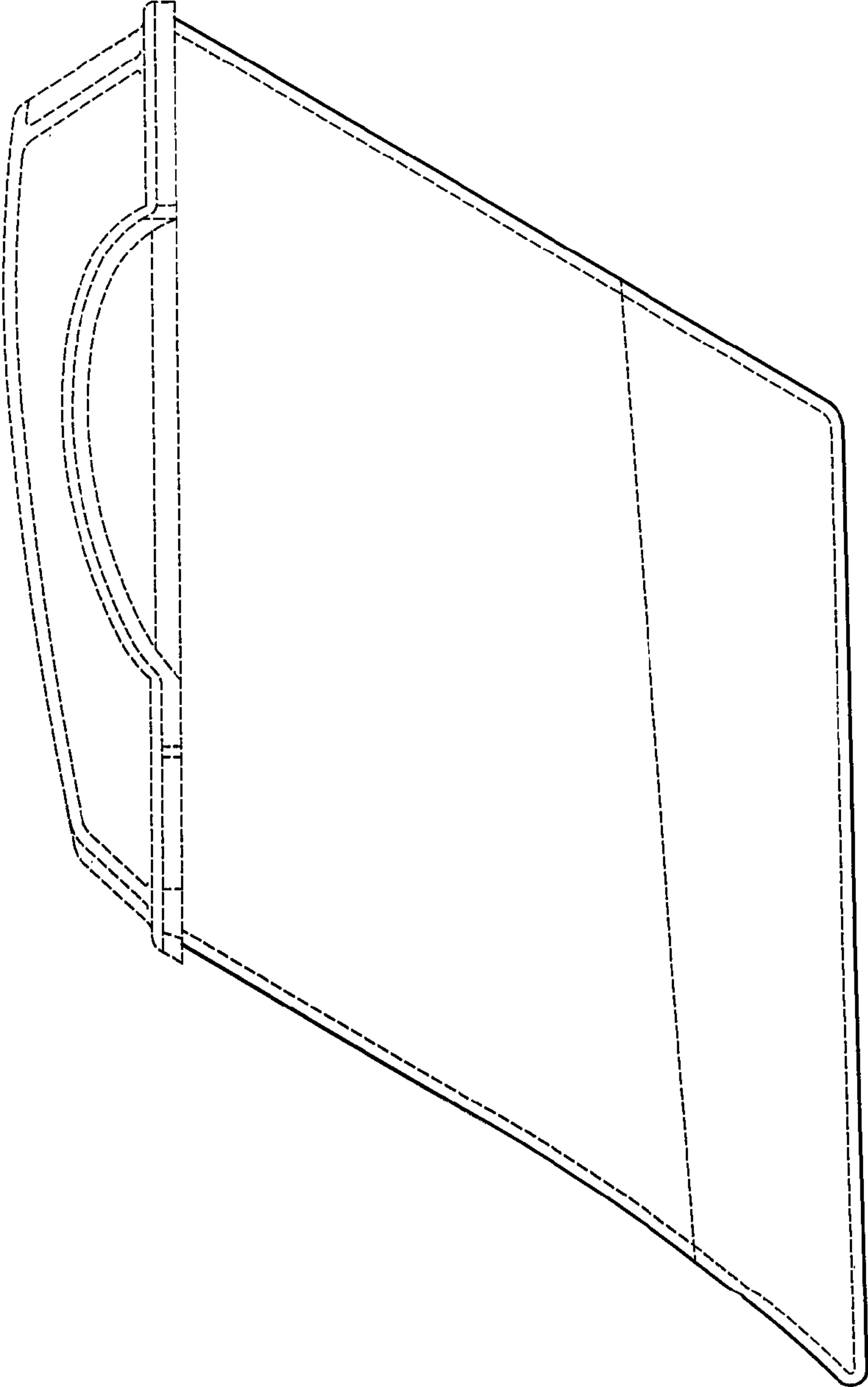

FIG. 4

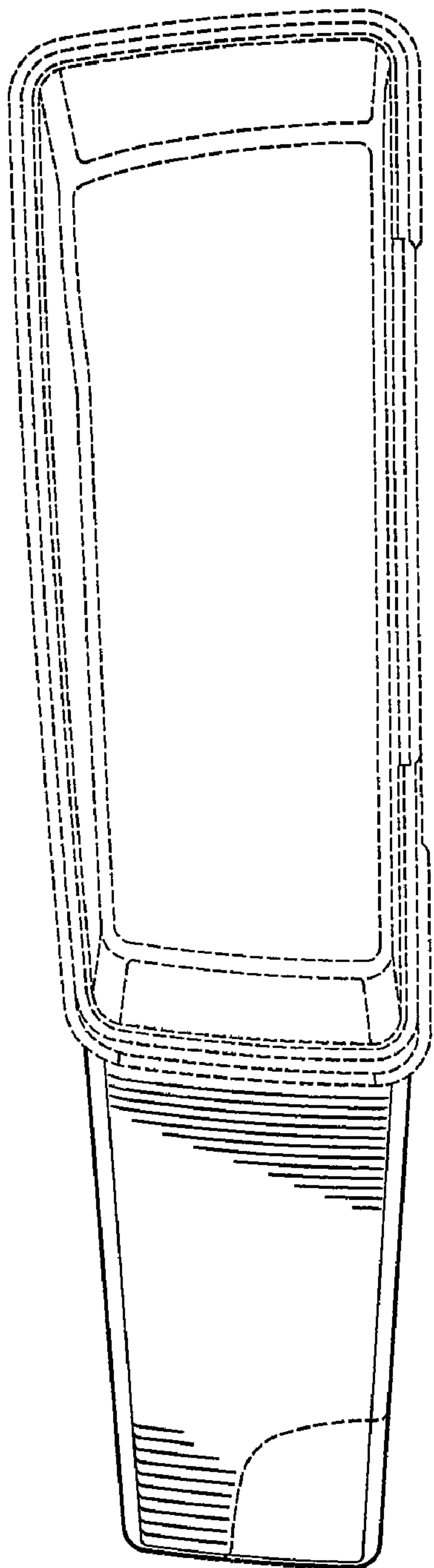

FIG. 6

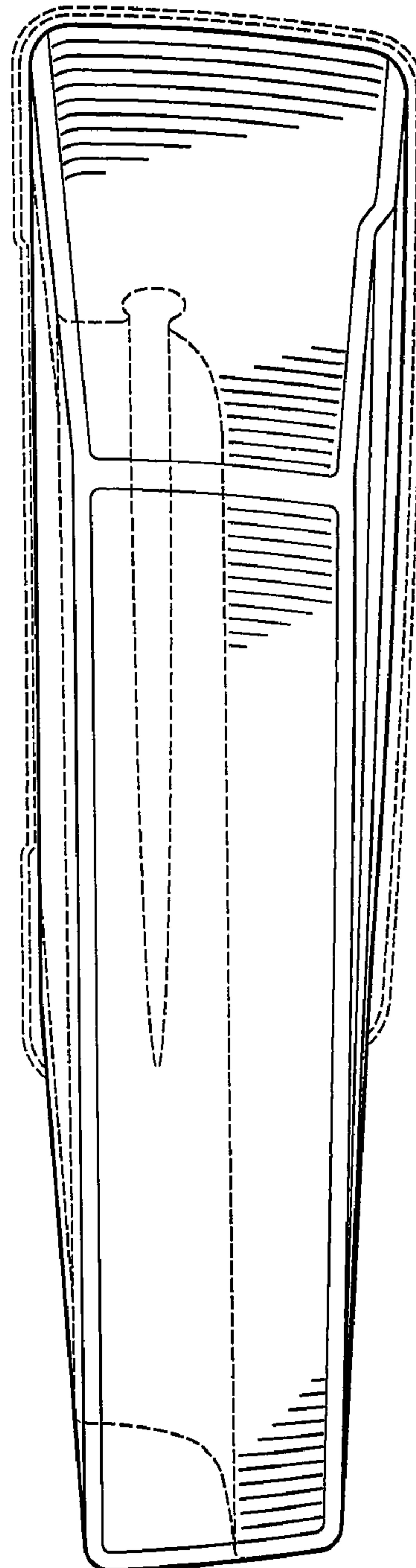

FIG. 7