



US00D675368S

(12) **United States Design Patent**  
**Leonard**

(10) **Patent No.:** **US D675,368 S**

(45) **Date of Patent:** **\*\* Jan. 29, 2013**

(54) **LAMP WITH ROTATING SHADE**

(76) **Inventor:** **John-Mark Leonard**, Niagara Falls  
(CA)

(\*\*) **Term:** **14 Years**

(21) **Appl. No.:** **29/409,979**

(22) **Filed:** **Dec. 30, 2011**

(51) **LOC (9) Cl.** ..... **26-99**

(52) **U.S. Cl.** ..... **D26/118**

(58) **Field of Classification Search** ..... D26/88,  
D26/91, 85, 86, 72, 74, 76, 118, 90, 134,  
D26/73, 75, 119, 120, 121, 122, 113, 71,  
D26/84, 128, 129, 2, 125, 78, 77, 138, 26,  
D26/89, 124, 130, 9, 10, 11, 24, 25, 63, 64,  
D26/65, 69, 127; 362/311.13, 249.01-249.12,  
362/373, 362, 326, 247, 342, 220, 147, 148,  
362/282, 339, 620, 223, 376, 219; D23/412,  
D23/385, 388; 349/64, 62, 63, 65; D16/101;  
D13/179, 180

See application file for complete search history.

(56) **References Cited**

**U.S. PATENT DOCUMENTS**

1,909,515	A *	5/1933	Baker et al.	.....	431/309
2,615,266	A *	10/1952	Wallin et al.	.....	40/430
2,629,044	A *	2/1953	Marfisi	.....	40/431
D174,398	S *	4/1955	Reachi	.....	D26/111
D186,618	S *	11/1959	Haywood	.....	D26/110
D195,987	S *	8/1963	Hoffman et al.	.....	D26/61
D204,013	S *	3/1966	Hall	.....	D26/128
D206,798	S *	1/1967	Hill	.....	D22/123
3,334,221	A *	8/1967	Aslund	.....	362/257
D214,186	S *	5/1969	Meltzer	.....	D26/85
D215,171	S *	9/1969	Meltzer	.....	D26/88
D217,086	S *	4/1970	Miller	.....	D22/123
4,203,719	A *	5/1980	Brandt	.....	431/352
4,490,931	A *	1/1985	Fleemin	.....	40/406
D388,197	S *	12/1997	Cardosi	.....	D26/9
D390,997	S *	2/1998	Markee	.....	D26/85

D393,003	S *	3/1998	Nichols	.....	D19/85
D400,989	S *	11/1998	Chen	.....	D26/11
D431,735	S *	10/2000	Sullivan	.....	D6/457
D435,134	S *	12/2000	Minissi et al.	.....	D26/85
D443,712	S *	6/2001	Minissi et al.	.....	D26/72
D444,254	S *	6/2001	Minissi et al.	.....	D26/72
6,550,936	B2 *	4/2003	Foley	.....	362/268
D515,247	S *	2/2006	Jung et al.	.....	D30/127
D541,957	S *	5/2007	Wang	.....	D26/2
D543,647	S *	5/2007	Goldenberg	.....	D26/22

(Continued)

**OTHER PUBLICATIONS**

John Geiger; Chapel of Extreme Experience—A Short History of Stroboscopic Light and The Dream Machine; accessed on Apr. 25, 2012; [www.johngeiger.net/flicker.html](http://www.johngeiger.net/flicker.html).

(Continued)

*Primary Examiner* — Kevin Rudzinski

(74) *Attorney, Agent, or Firm* — Steven M. Greenberg, Esq.;  
Carey Rodriguez Greenberg & O’Keefe, LLP

(57) **CLAIM**

The ornamental design for a lamp with a rotating shade, as shown and described.

**DESCRIPTION**

FIG. 1 is a top perspective view of a lamp with a rotating shade, according to my new design.

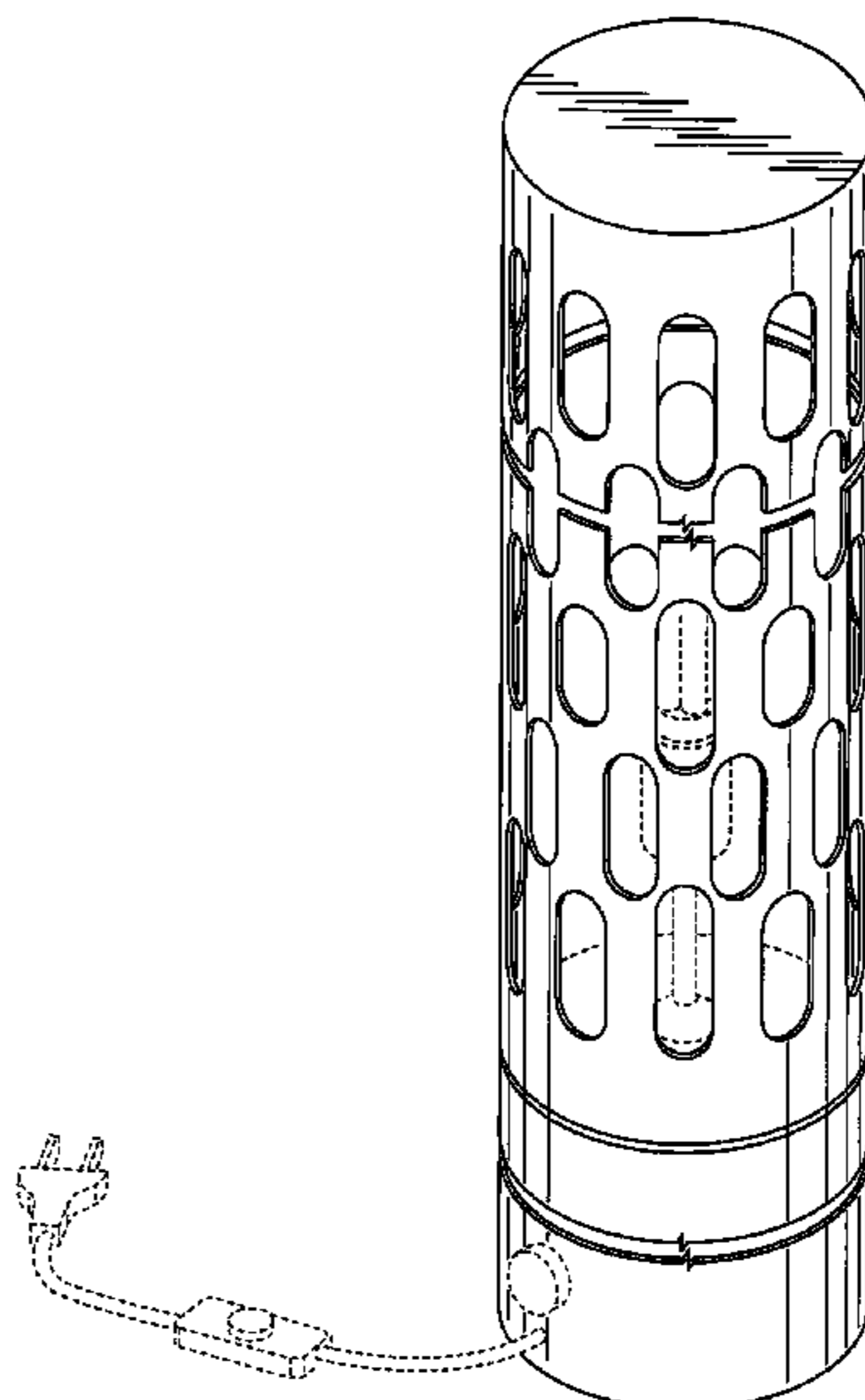
FIG. 2 is a side view thereof.

FIG. 3 is a top view thereof; and,

FIG. 4 is a bottom view thereof.

This design is directed to a lamp with a rotating shade. The broken line showing of parts of the drawings is included for the purpose of illustrating use and environment and forms no part of the claimed design. The lamp of FIGS. 1 and 2 is shown in the views with portions broken away to indicate indeterminate length; the precise length of the upper and lower portions of the lamp is not claimed.

**1 Claim, 3 Drawing Sheets**



U.S. PATENT DOCUMENTS

D544,636	S *	6/2007	McMinn	.....	D26/118
D577,456	S *	9/2008	Schwendinger et al.	.....	D26/72
D585,583	S *	1/2009	Campbell	.....	D26/88
D593,702	S *	6/2009	Sabernig	.....	D26/88
D596,783	S *	7/2009	Silver	.....	D26/90
D598,152	S *	8/2009	Tortel	.....	D26/68
D612,531	S *	3/2010	Smith	.....	D26/137
D620,184	S *	7/2010	Sabernig	.....	D26/88
D620,631	S *	7/2010	Wildner	.....	D26/88
D625,876	S *	10/2010	Chen et al.	.....	D26/74
7,832,909	B2 *	11/2010	Wang	.....	362/364
D629,259	S *	12/2010	Joy et al.	.....	D7/624.2
D631,581	S *	1/2011	Franklin	.....	D26/22
D633,229	S *	2/2011	McWillis	.....	D26/9
D634,052	S *	3/2011	Sabernig	.....	D26/88
D643,567	S *	8/2011	Gutting	.....	D26/88
D644,072	S *	8/2011	McDonald et al.	.....	D7/667
D664,280	S *	7/2012	Campbell	.....	D26/88
2002/0176260	A1 *	11/2002	Liao	.....	362/551
2007/0287117	A1 *	12/2007	Chang	.....	431/296
2009/0296402	A1 *	12/2009	Chang et al.	.....	362/294

OTHER PUBLICATIONS

Katy Diamond Hamer; Eyes Towards The Dove Members Event @ the New Museum; Jul. 14, 2010; accessed on Apr. 25, 2012; [www.eyes-towards-the-dove.com/2010/07/members-event-new-museum.html](http://www.eyes-towards-the-dove.com/2010/07/members-event-new-museum.html).

Randy Kennedy; The Unknown Loved by the Knowns; The New York Times; Jun. 23, 2010; accessed on Apr. 25, 2012; [www.nytimes.com/2010/06/27/arts/design/27gysin.html?\\_r=2](http://www.nytimes.com/2010/06/27/arts/design/27gysin.html?_r=2).

The October Gallery Brion Gysin; accessed on Apr. 26, 2012; [www.octobergallery.co.uk/artists/gysin/index.shtml](http://www.octobergallery.co.uk/artists/gysin/index.shtml).

Brion Gysin's Dreamachine; accessed on Apr. 26, 2012; [www.10111.org/dreamachine/](http://www.10111.org/dreamachine/).

Daniel Guaida; Dreamachine/Machine A Rever; accessed on Apr. 26, 2012; [www.inter-zone.org/dm.html](http://www.inter-zone.org/dm.html).

Izzy; How to Build A Simple And Cheap Dreamachine; accessed on Apr. 26, 2012; [www.interpc.fr/mapage/westernlands/dreamchine.html](http://www.interpc.fr/mapage/westernlands/dreamchine.html).

Nik Sheehan; Flicker, A Film by Nick Sheehan; accessed on Apr. 26, 2012; [www.flickerflicker.com/flash/index.html](http://www.flickerflicker.com/flash/index.html).

Flicker, A Film By Nick Sheehan; accessed on Apr. 26, 2012; [www.flicker.myfilmblog.com/](http://www.flicker.myfilmblog.com/).

Dream State; accessed on Apr. 26, 2012; [www.dreamstateuk.com/](http://www.dreamstateuk.com/).

LVB Research; The Dreamachine And Brainwave Entertainment; accessed on Apr. 26, 2012; <http://lvb-research.blogspot.ca/2010/05/dreamachine-and-brainwave-entertainment.html>.

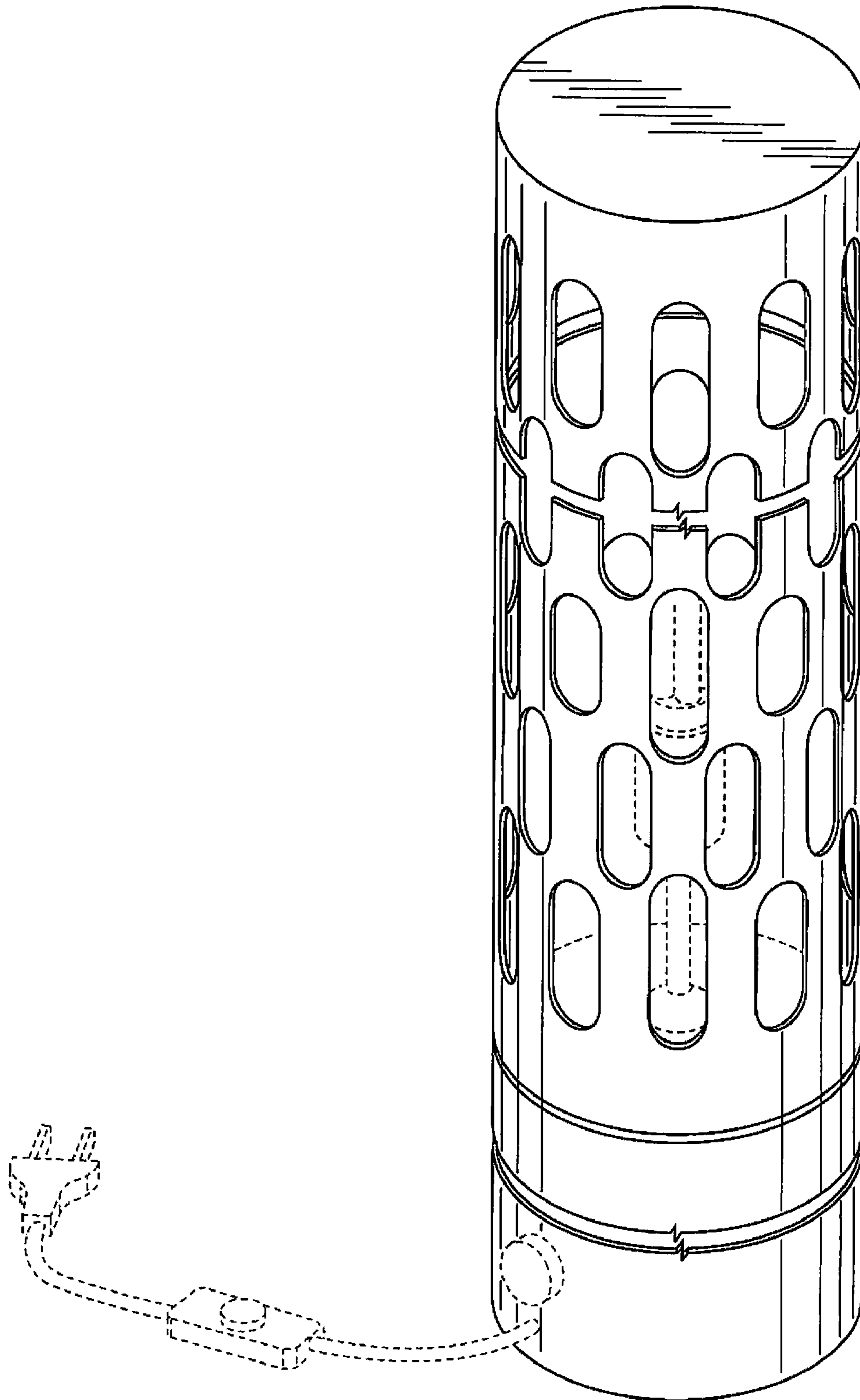
Wikipedia; Dreamachine; accessed on Apr. 27, 2012; <http://en.wikipedia.org/wiki/Dreamachine>.

Brion Gysin's Dreamachine; accessed on Apr. 27, 2012; [www.10111.org/0.php?wakka=Dreamachine](http://www.10111.org/0.php?wakka=Dreamachine).

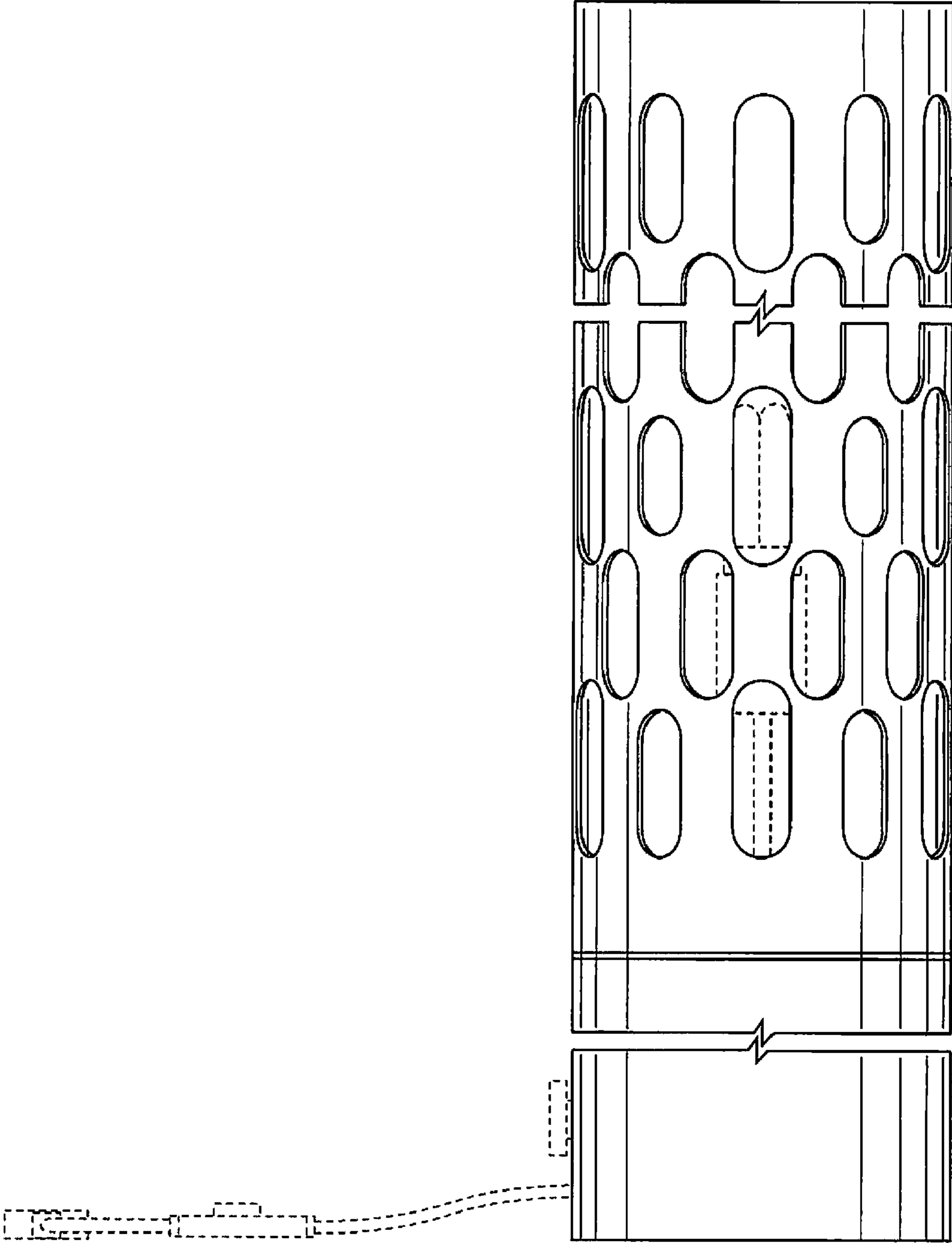
YouTube; Dreamachine; accessed on Apr. 27, 2012; [www.youtube.com/results?search\\_type=search\\_playlists&search\\_query=dreamchine&uni=1](http://www.youtube.com/results?search_type=search_playlists&search_query=dreamchine&uni=1).

Reality Studio; Playing With Fire: The Last Painting Of Brion Gysin; accessed on Apr. 25, 2012; <http://realitystudio.org/criticism/playing-with-fire-the-last-painting-of-brion-gysin/>.

\* cited by examiner

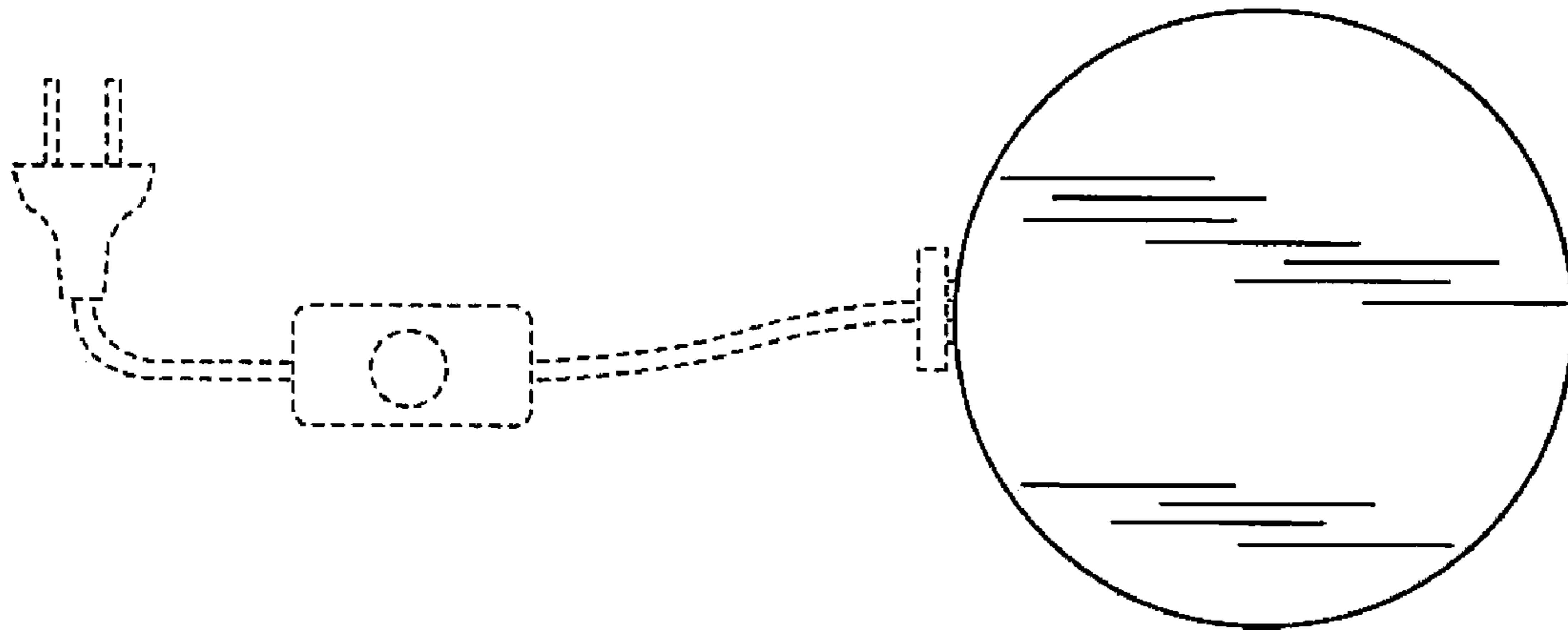


**FIG. 1**

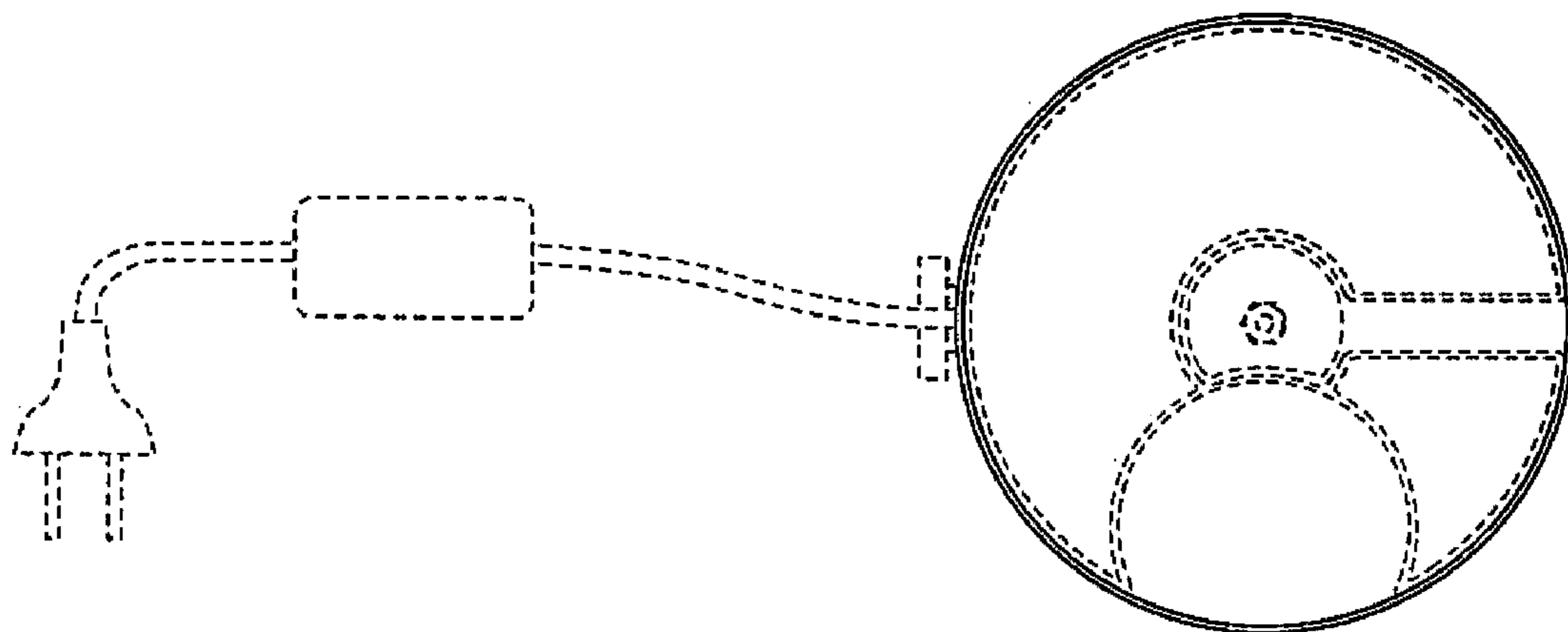


**FIG. 2**





**FIG. 3**



**FIG. 4**