



US00D675039S

(12) **United States Design Patent**
Foisy

(10) **Patent No.:** **US D675,039 S**
(45) **Date of Patent:** **** Jan. 29, 2013**

(54) **GUITAR STAND**

(76) **Inventor:** **Gerald P. Foisy**, Gainesville, GA (US)

(**) **Term:** **14 Years**

(21) **Appl. No.:** **29/412,653**

(22) **Filed:** **Feb. 6, 2012**

(51) **LOC (9) Cl.** **06-04**

(52) **U.S. Cl.** **D6/466**

(58) **Field of Classification Search** D6/395,
D6/396, 429, 449, 450, 453-469; 211/1,
211/2, 13.1, 44, 45, 72, 85.2, 85.6, 85.8,
211/85.14, 85.31, 86.01, 189; D14/447;
D17/20; 84/327; 248/166

See application file for complete search history.

(56) **References Cited**

U.S. PATENT DOCUMENTS

D236,227 S	8/1975	Kester	
D260,589 S	9/1981	O'Brien	
4,691,610 A	9/1987	Gilbert	
D329,342 S	9/1992	Schoenig	
D332,882 S	2/1993	Graves	
D353,729 S	12/1994	MacOwen	
D392,123 S	3/1998	Lynch	
D396,579 S *	8/1998	Kalayjian	D6/462
D482,904 S	12/2003	Slaymaker	
6,835,883 B2	12/2004	Stevens	
D506,774 S	6/2005	Stevens	
D610,835 S *	3/2010	Mono	D6/466

D613,524 S *	4/2010	Jeffers	D6/466
D628,830 S *	12/2010	Mono	D6/466
D646,505 S *	10/2011	Eason	D6/466

* cited by examiner

Primary Examiner — Mary Ann Calabrese

(74) *Attorney, Agent, or Firm* — QuickPatents, Inc.; Kevin Prince

(57) **CLAIM**

I claim the ornamental design for a guitar stand, as shown and described.

DESCRIPTION

FIG. 1 is a perspective view of a guitar stand, showing a first embodiment of my new design;
 FIG. 2 is a right-side elevational view of FIG. 1, the left-side elevational view being a mirror image thereof;
 FIG. 3 is a top plan view of FIG. 1;
 FIG. 4 is a front elevational view of FIG. 1;
 FIG. 5 is a rear elevational view of FIG. 1;
 FIG. 6 is a bottom plan view of FIG. 1;
 FIG. 7 is a perspective view of a second embodiment thereof;
 FIG. 8 is a top plan view of FIG. 7;
 FIG. 9 is a right-side elevational view of FIG. 7, the left-side elevational view being a mirror image thereof;
 FIG. 10 is a rear elevational view thereof;
 FIG. 11 is a front elevational view thereof; and,
 FIG. 12 is a bottom plan view thereof.

The broken lines showing a guitar in FIGS. 1 and 7 depict environmental matter and form no part of the claimed design.

1 Claim, 3 Drawing Sheets

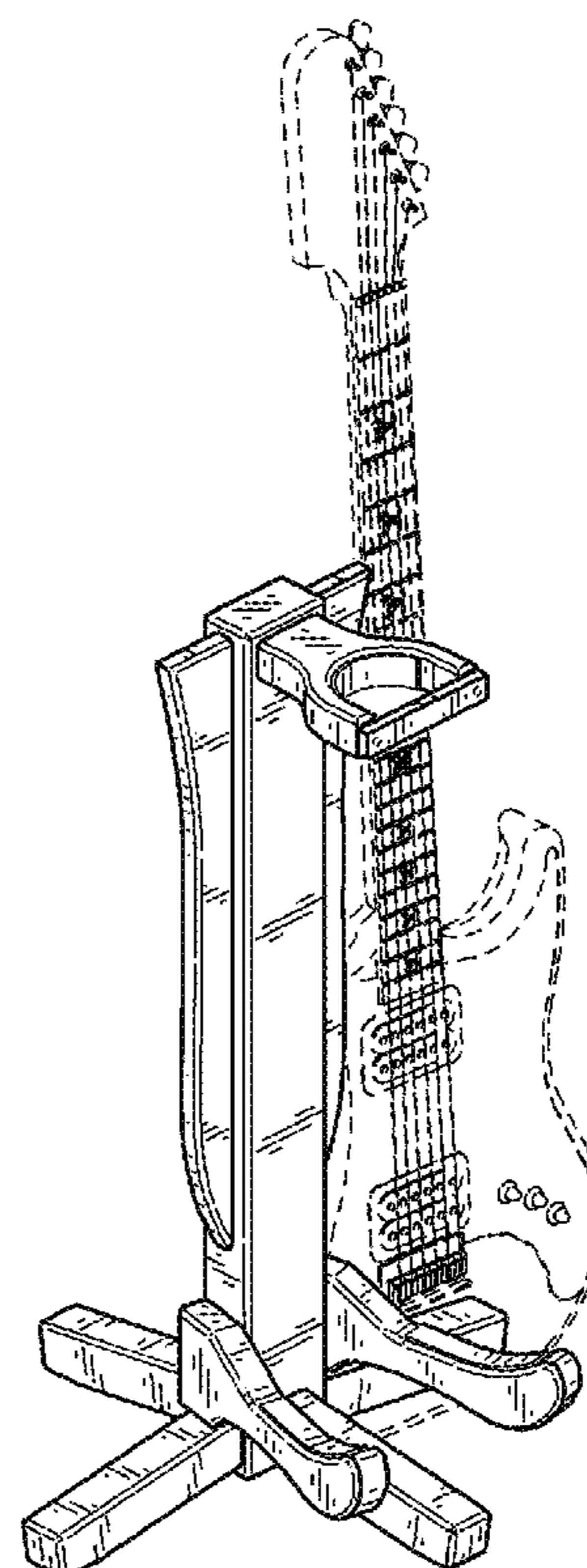
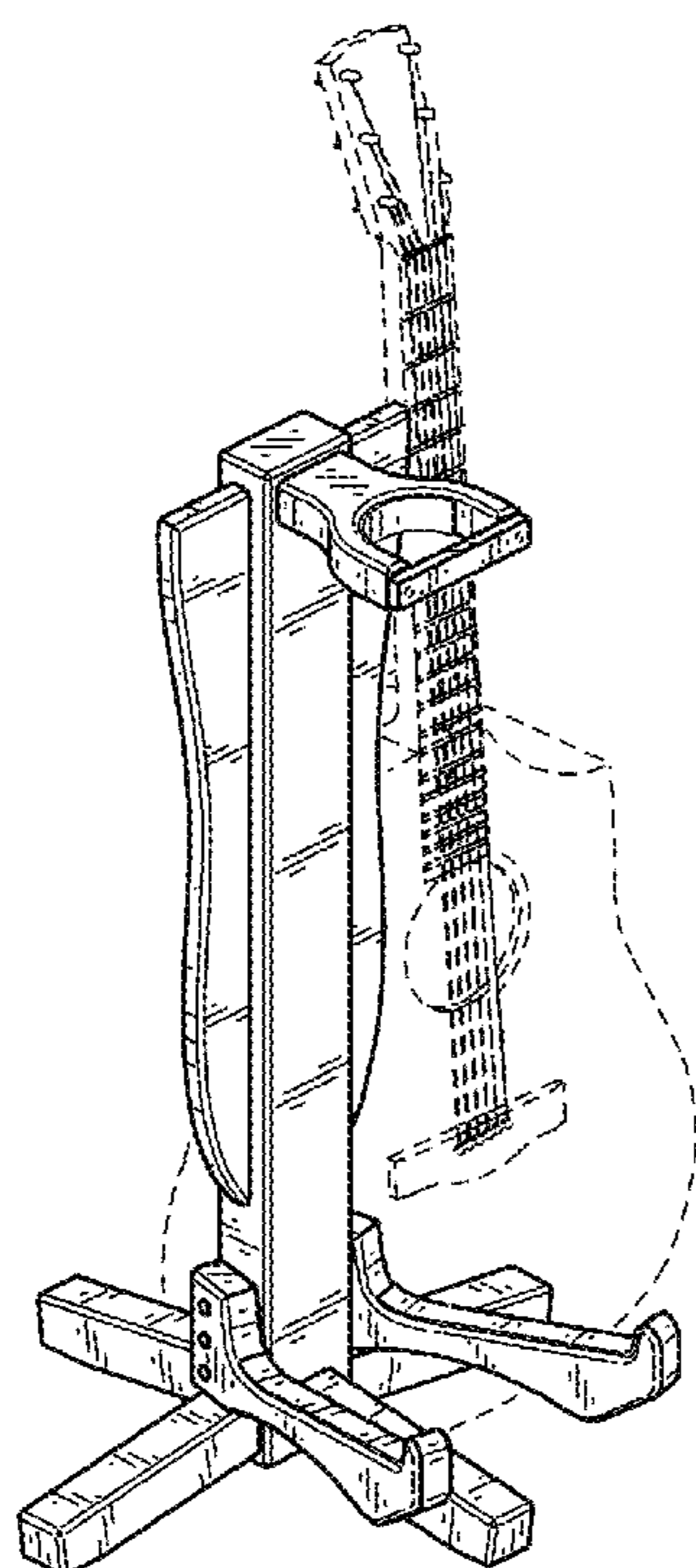

FIG. 1

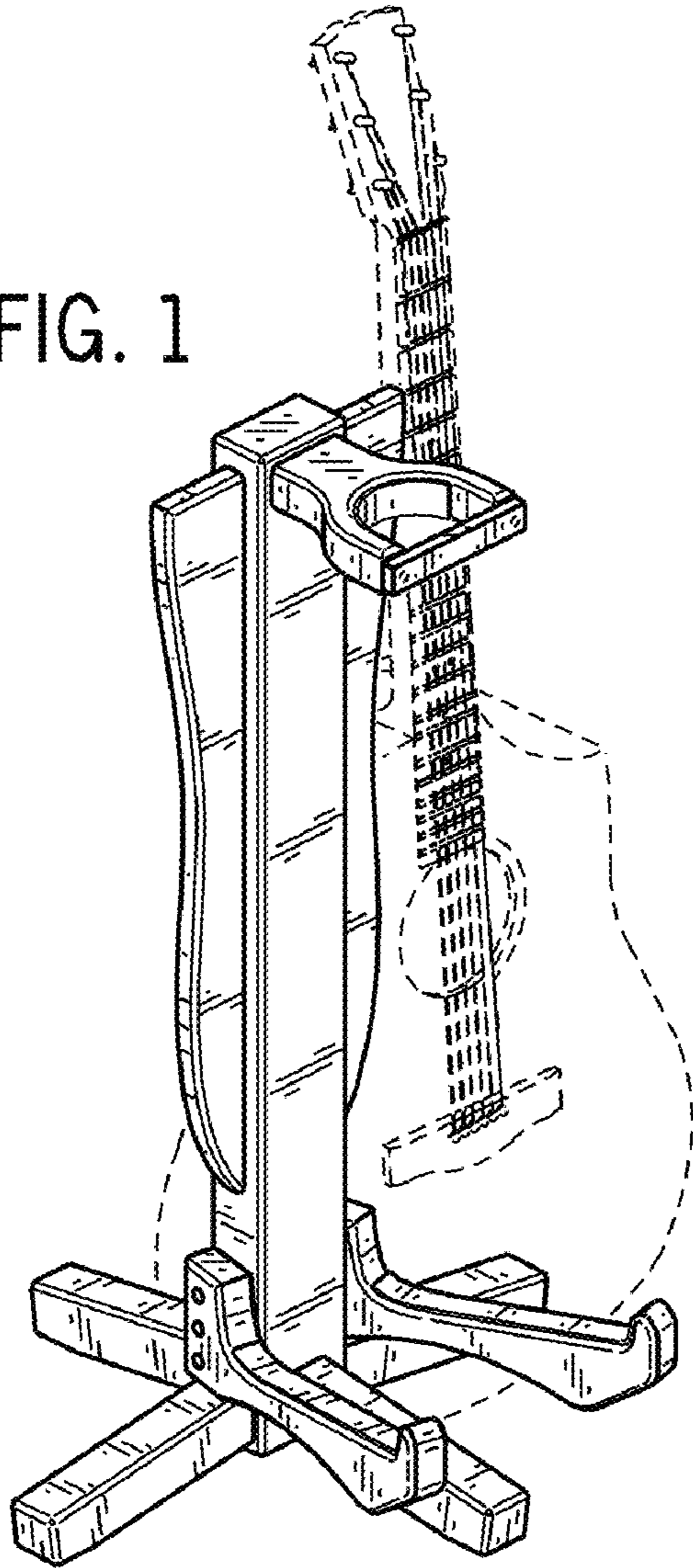

FIG. 2

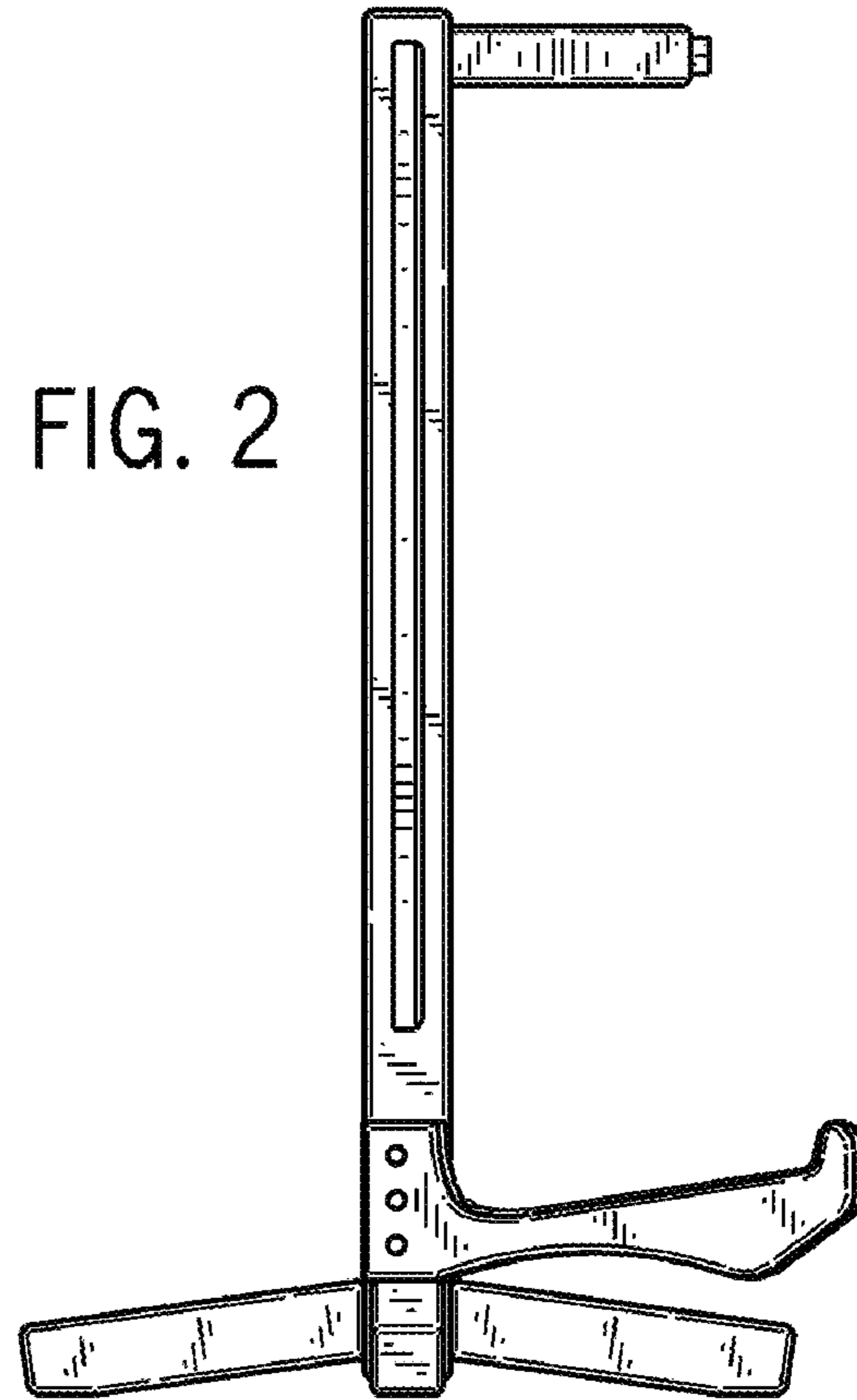

FIG. 3

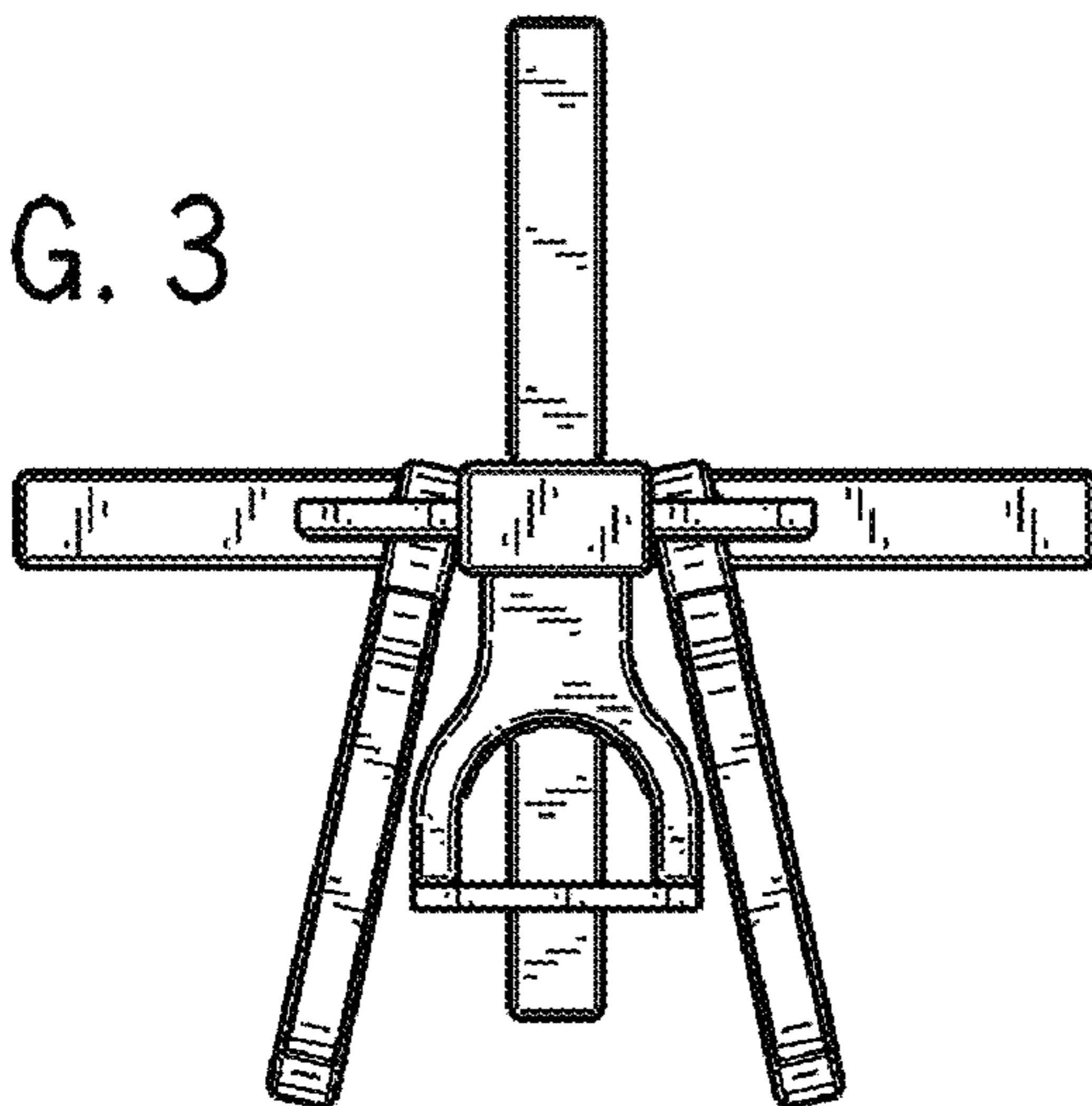

FIG. 4

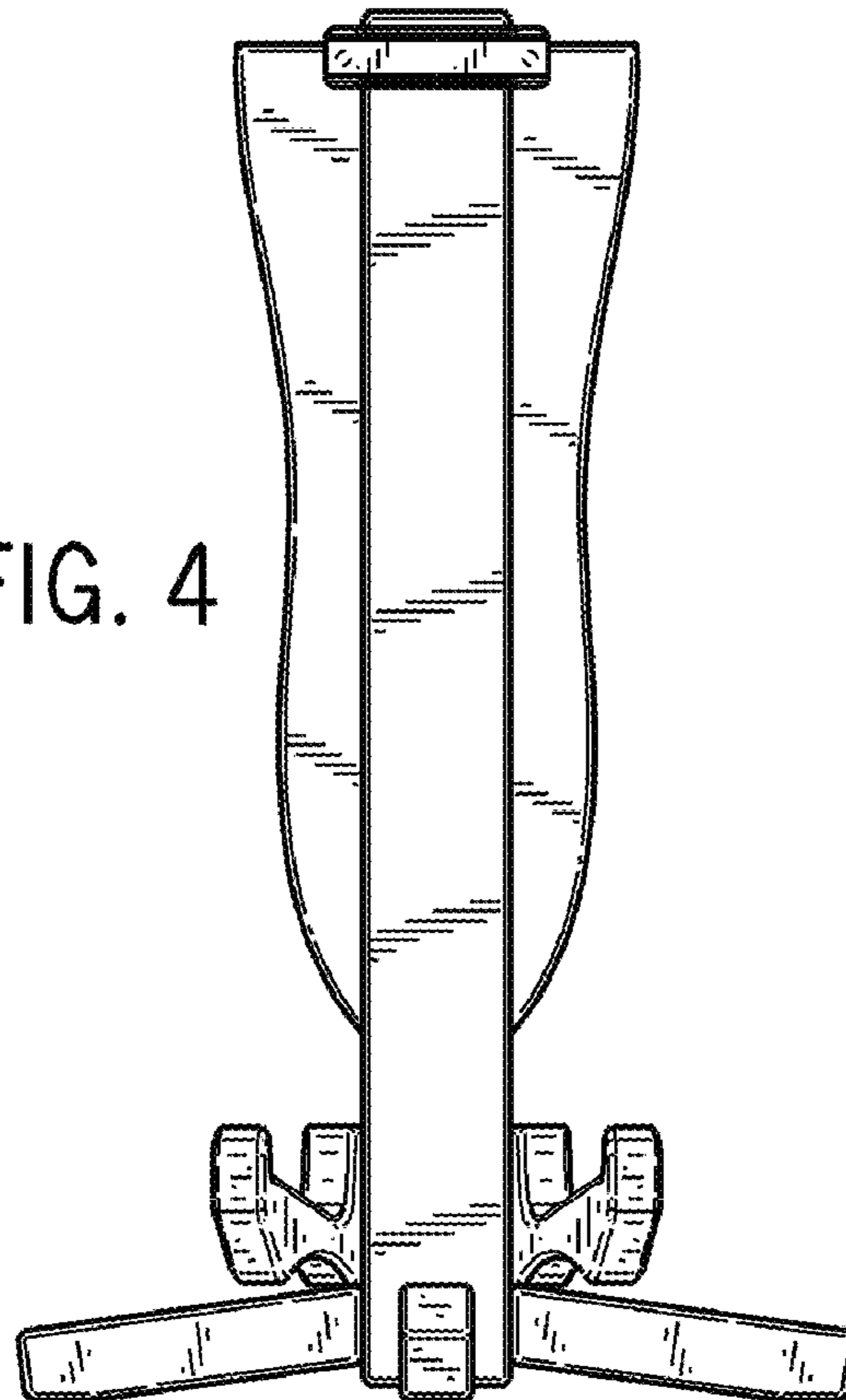

FIG. 5

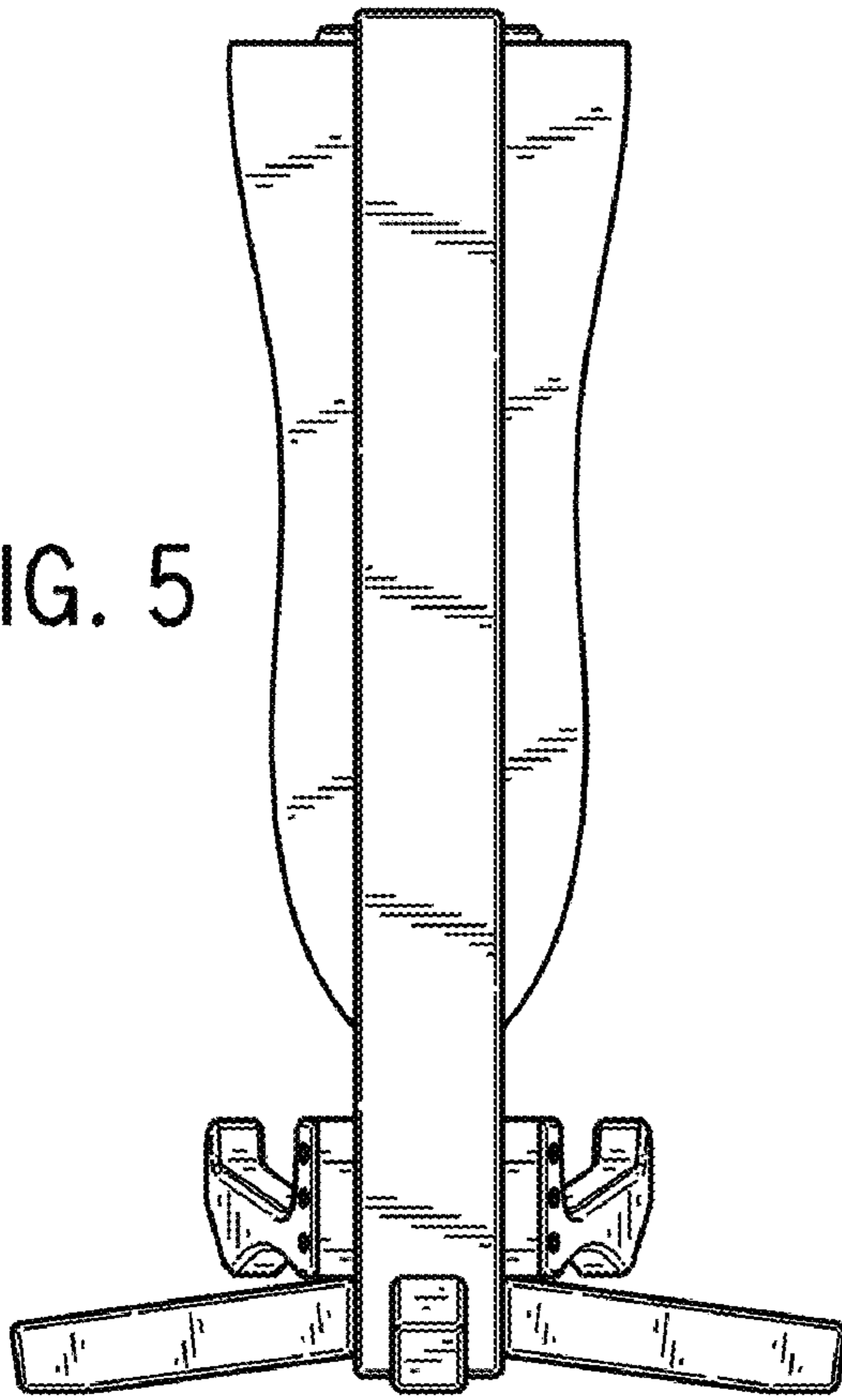

FIG. 7

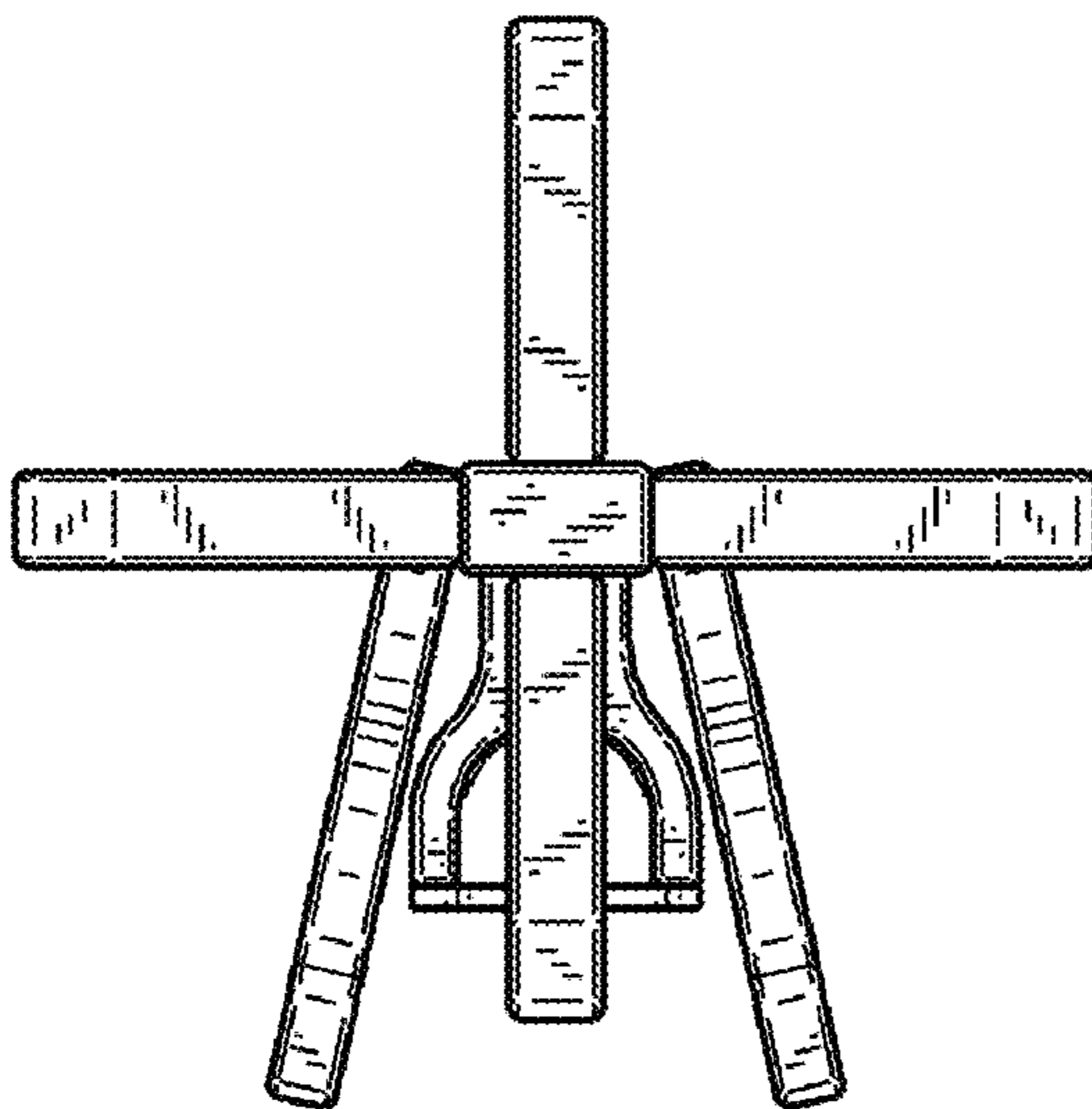
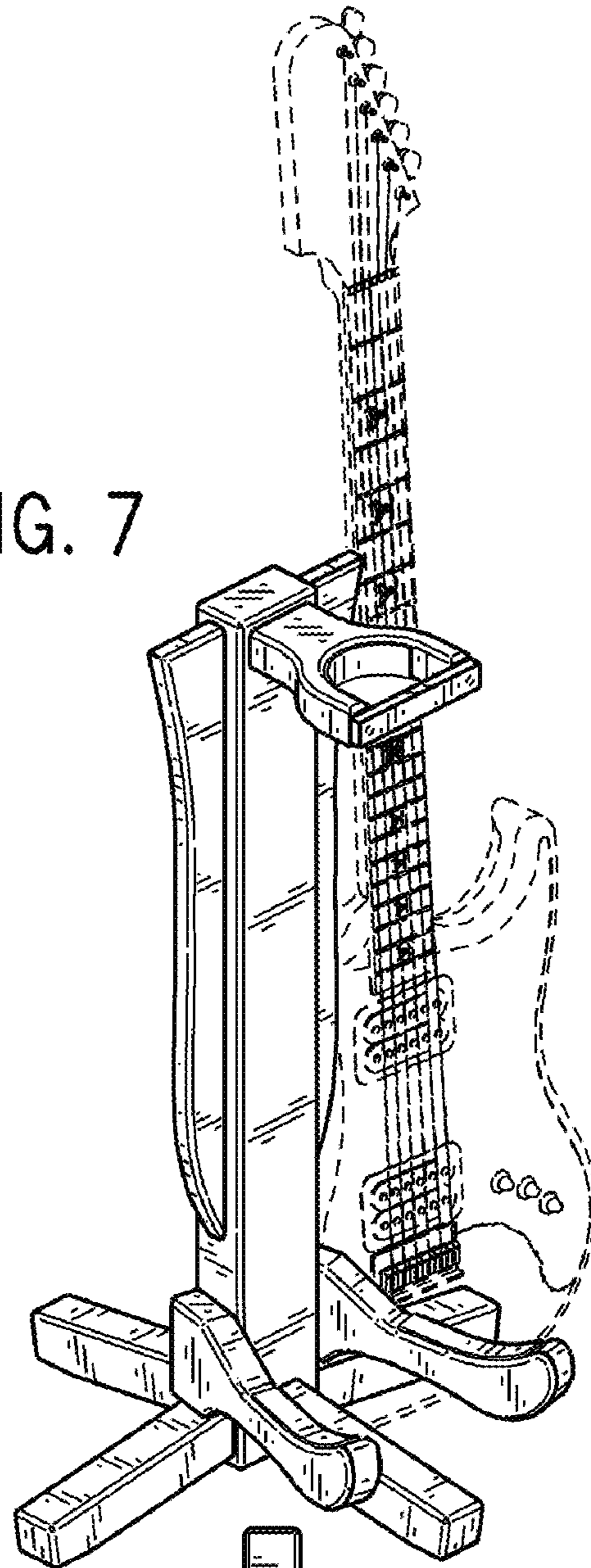

FIG. 6

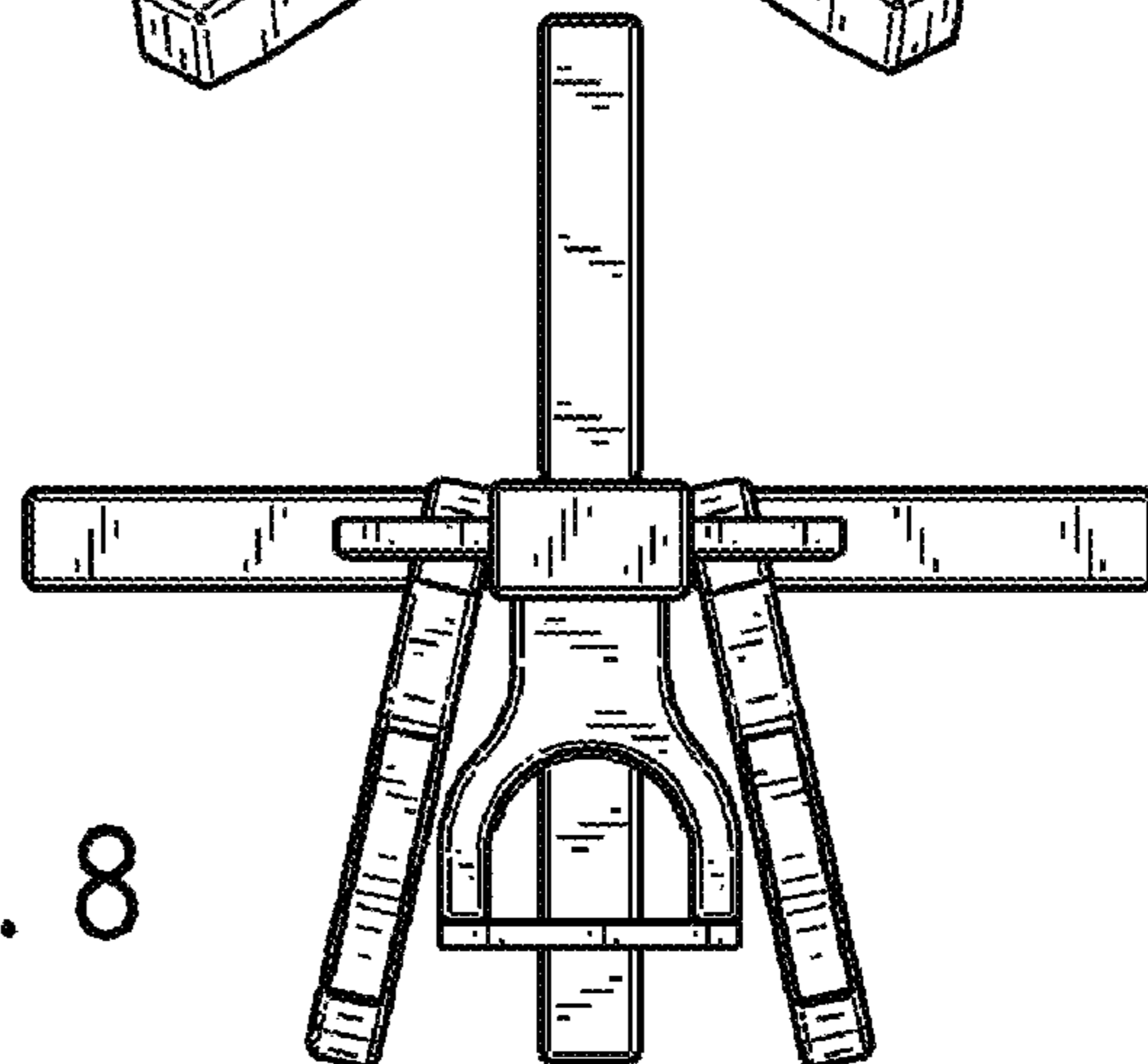

FIG. 8

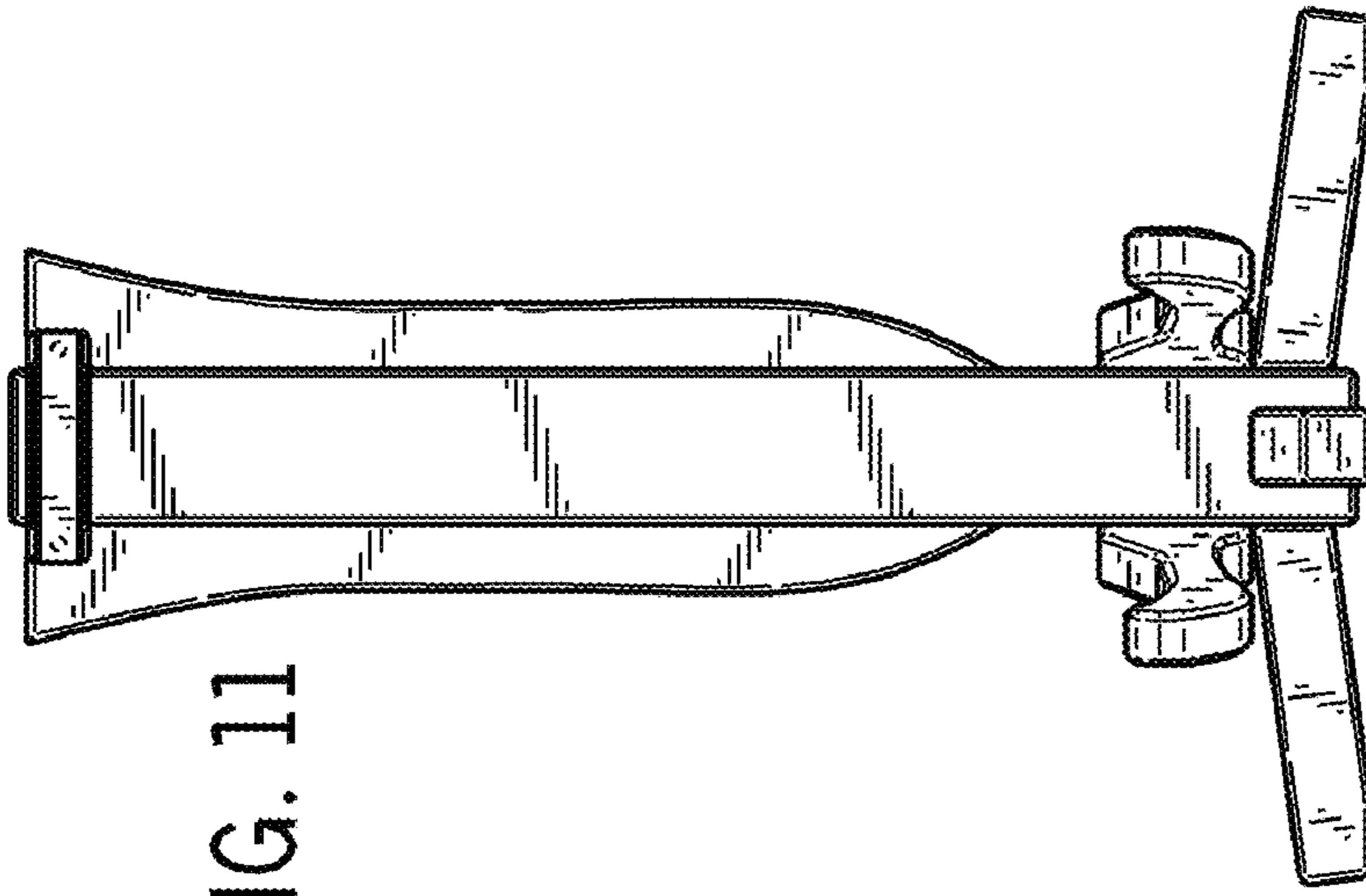

FIG. 9

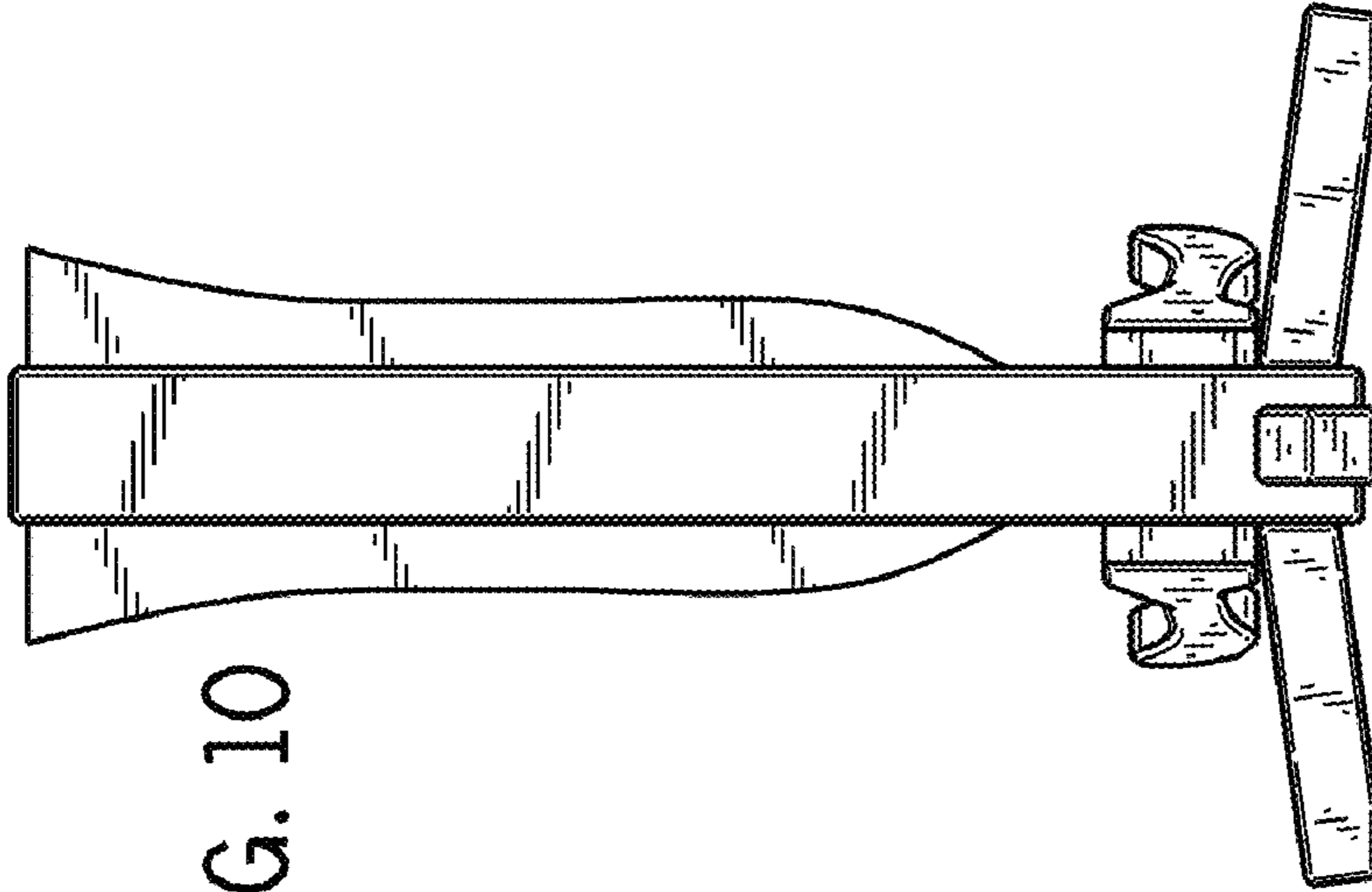

FIG. 10

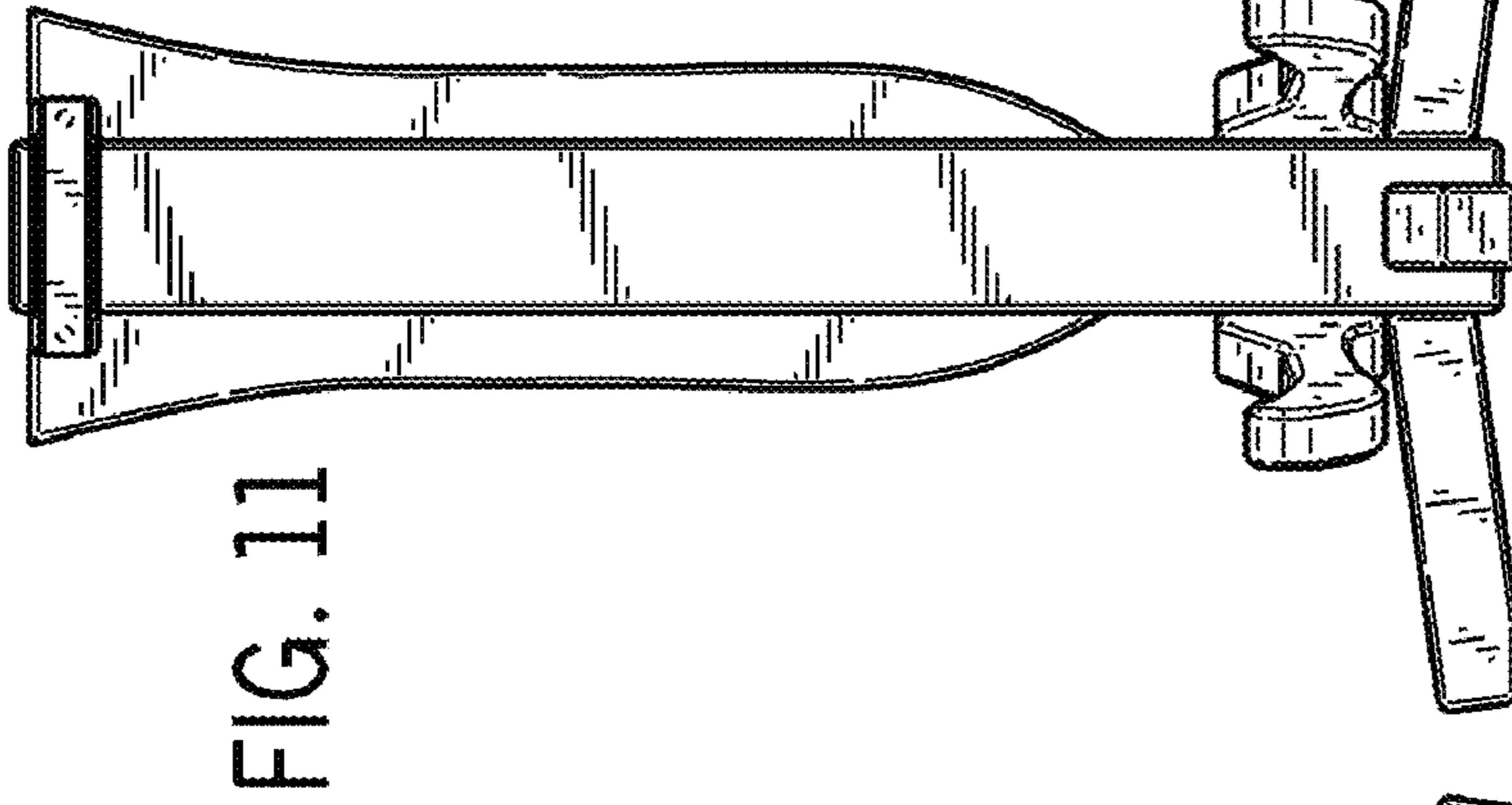

FIG. 11

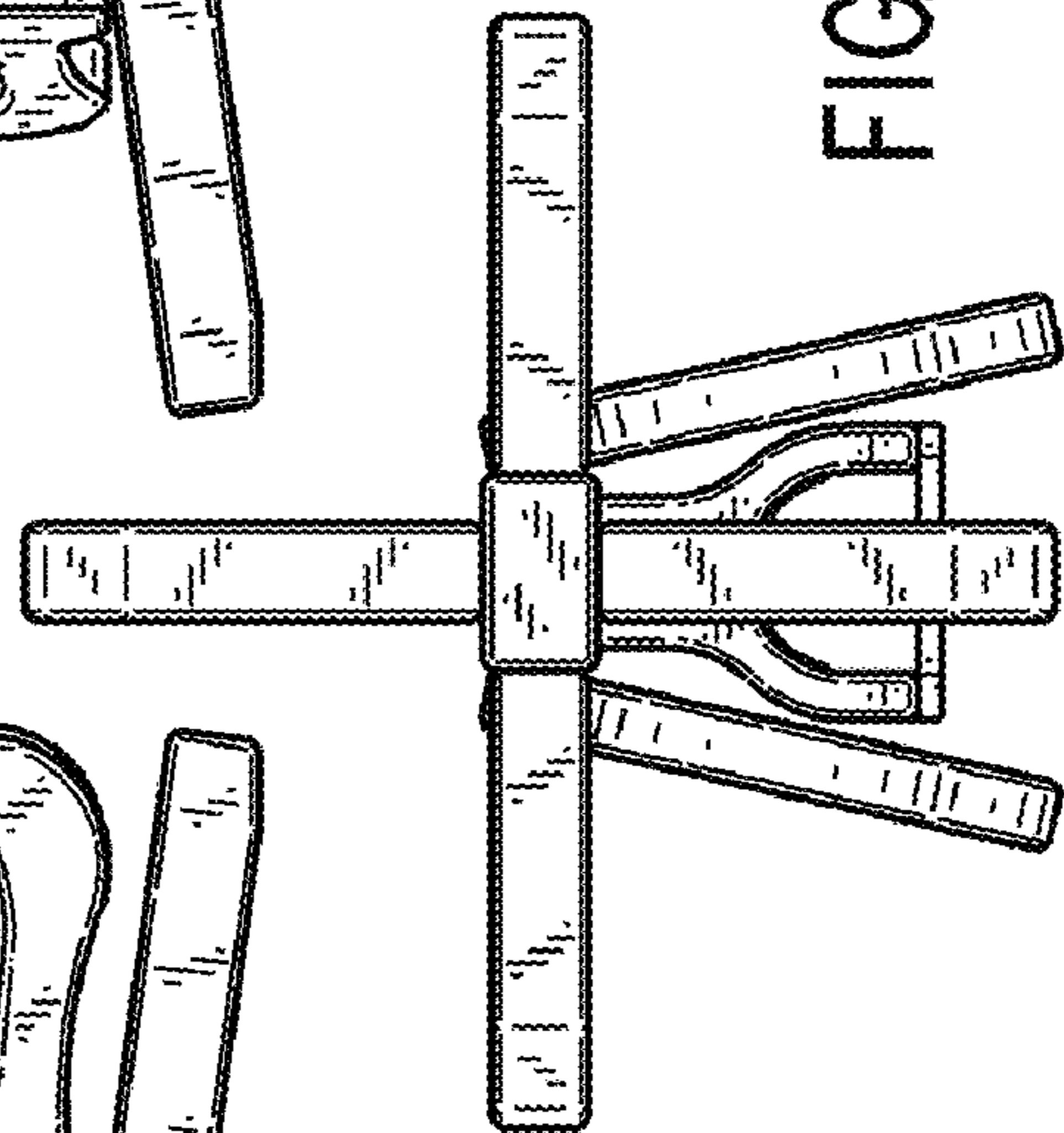

FIG. 12