



US00D674827S

(12) **United States Design Patent**
Andersson

(10) **Patent No.:** **US D674,827 S**
(45) **Date of Patent:** **** Jan. 22, 2013**

(54) **GEAR DRIVE**

(75) Inventor: **Jan Andersson**, Erlangen (DE)

(73) Assignee: **Siemens Aktiengesellschaft**, München (DE)

(**) Term: **14 Years**

(21) Appl. No.: **29/403,881**

(22) Filed: **Oct. 12, 2011**

(30) **Foreign Application Priority Data**

Apr. 12, 2011 (EM) 001270516

(51) **LOC (9) Cl.** **15-99**

(52) **U.S. Cl.** **D15/148**

(58) **Field of Classification Search** D15/5,
D15/148, 149, 199; 74/395, 464; 280/5.5-5.524;
427/249.19; 428/408; 475/83, 331-335,
475/344, 345, 901

See application file for complete search history.

(56) **References Cited**

U.S. PATENT DOCUMENTS

D368,919 S *	4/1996	Lannoch	D15/148
D406,596 S *	3/1999	Ziegler et al.	D15/148
D410,659 S *	6/1999	Lannoch	D15/148
D414,790 S *	10/1999	Lannoch	D15/148
D416,922 S *	11/1999	Lannoch	D15/148

D417,229 S *	11/1999	Lannoch	D15/148
6,432,022 B1 *	8/2002	Bayer	475/331
D479,541 S *	9/2003	Lannoch	D15/148
D479,543 S *	9/2003	Lannoch	D15/148
D479,725 S *	9/2003	Lannoch	D15/148
D514,607 S *	2/2006	Wittenstein	D15/148
D527,739 S *	9/2006	De Luca et al.	D15/5
D529,059 S *	9/2006	Lin	D15/148
7,182,709 B2 *	2/2007	Christ et al.	475/348
D571,837 S *	6/2008	Lannoch	D15/148
D598,938 S *	8/2009	Mijno	D15/148
D613,770 S *	4/2010	Kitamura et al.	D15/7
D619,631 S *	7/2010	Otsuka	D15/149
D654,092 S *	2/2012	Lugli et al.	D15/5
2004/0166986 A1 *	8/2004	Bayer et al.	475/331

* cited by examiner

Primary Examiner — Patricia Palasik

(74) *Attorney, Agent, or Firm* — Henry M. Feiereisen, LLC

(57) **CLAIM**

The ornamental design for a gear drive, as shown and described.

DESCRIPTION

FIG. 1 is a front elevational view of a gear drive;
FIG. 2 is a rear elevational view thereof;
FIG. 3 is a top plan view thereof;
FIG. 4 is a bottom plan view thereof;
FIG. 5 is a left side elevational view thereof;
FIG. 6 is a right side elevational view thereof; and,
FIG. 7 is a front, left side and top perspective view thereof.

1 Claim, 7 Drawing Sheets

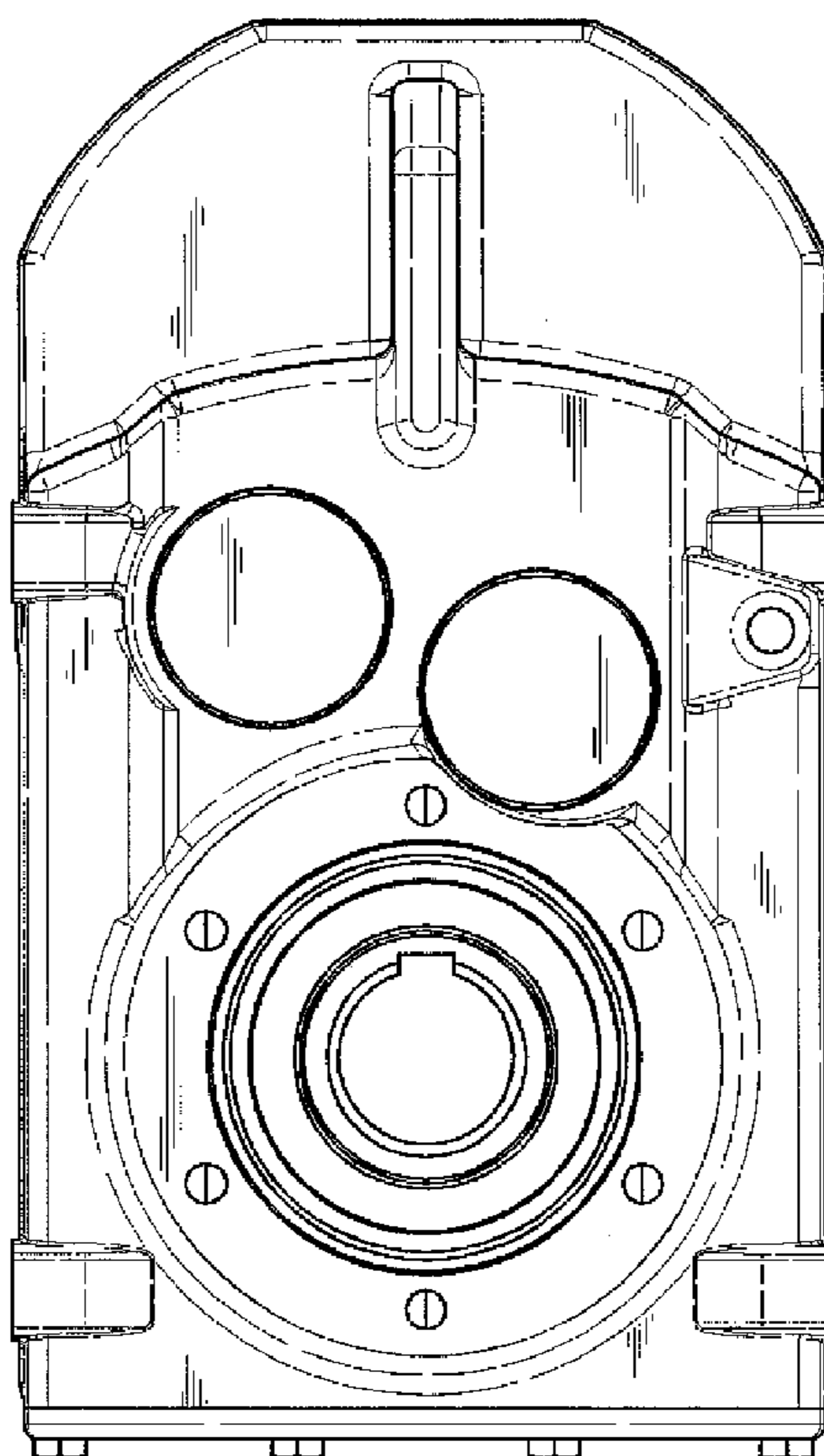

FIG.1

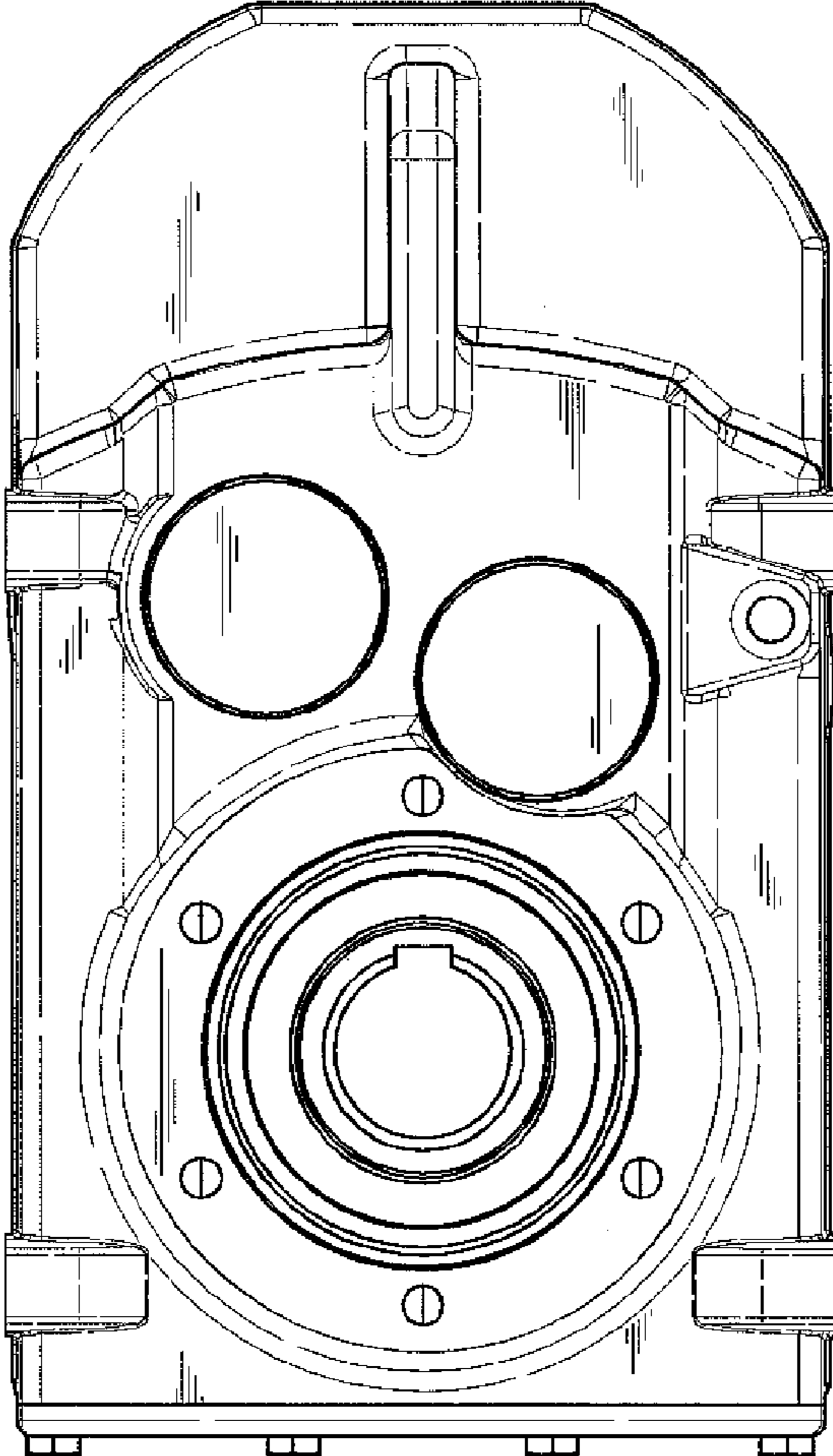

FIG 2

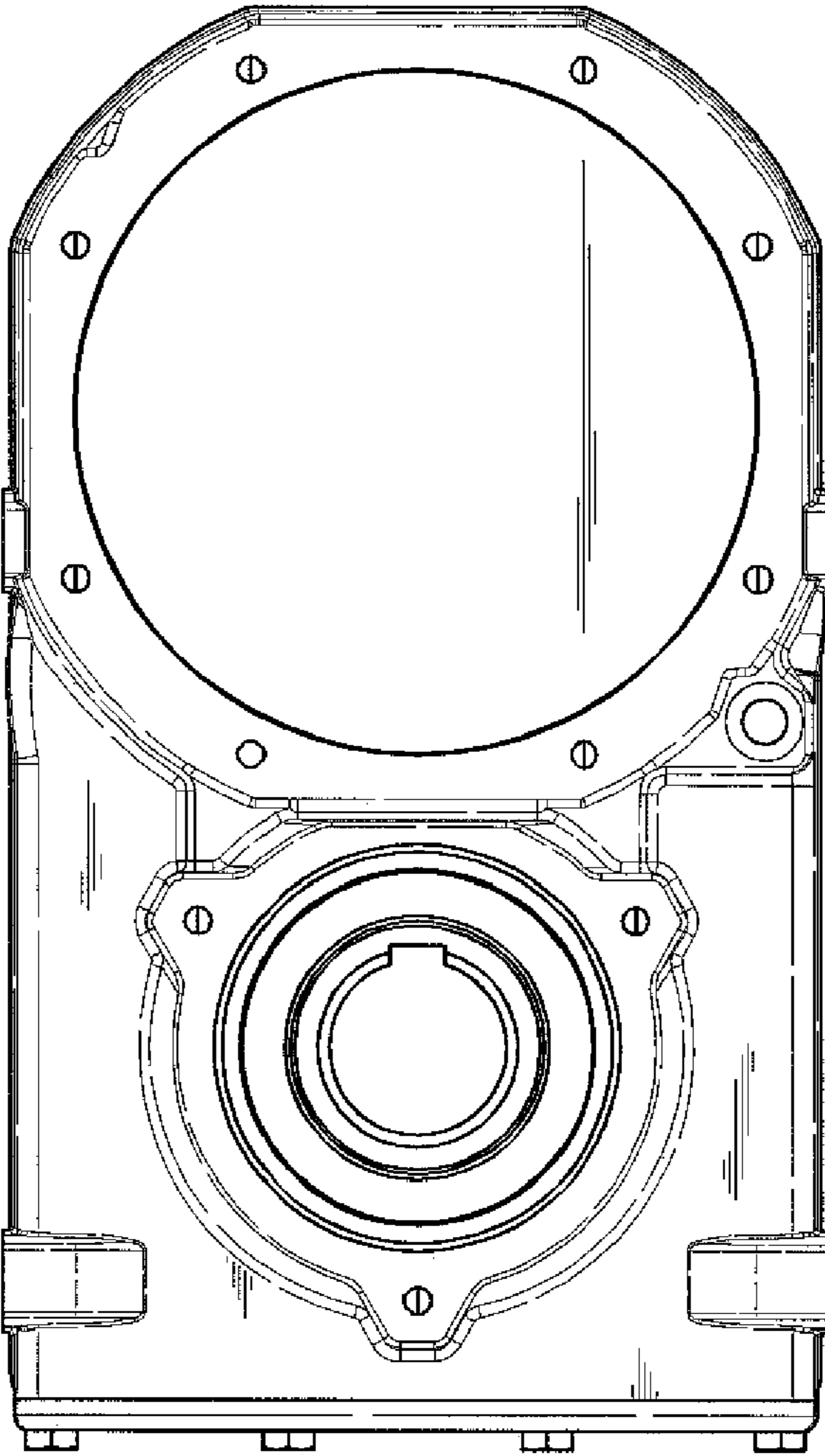

FIG 3

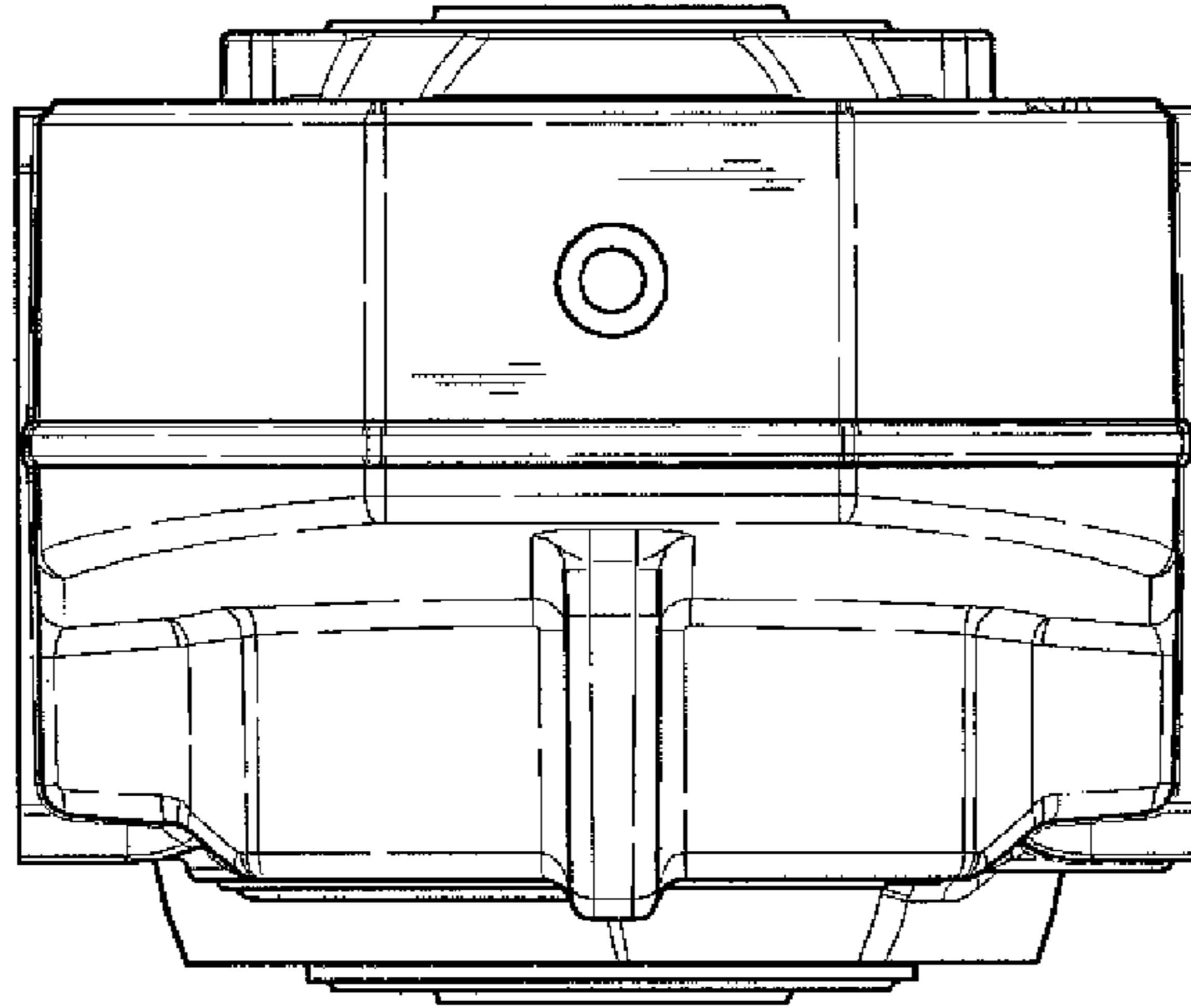

FIG 4

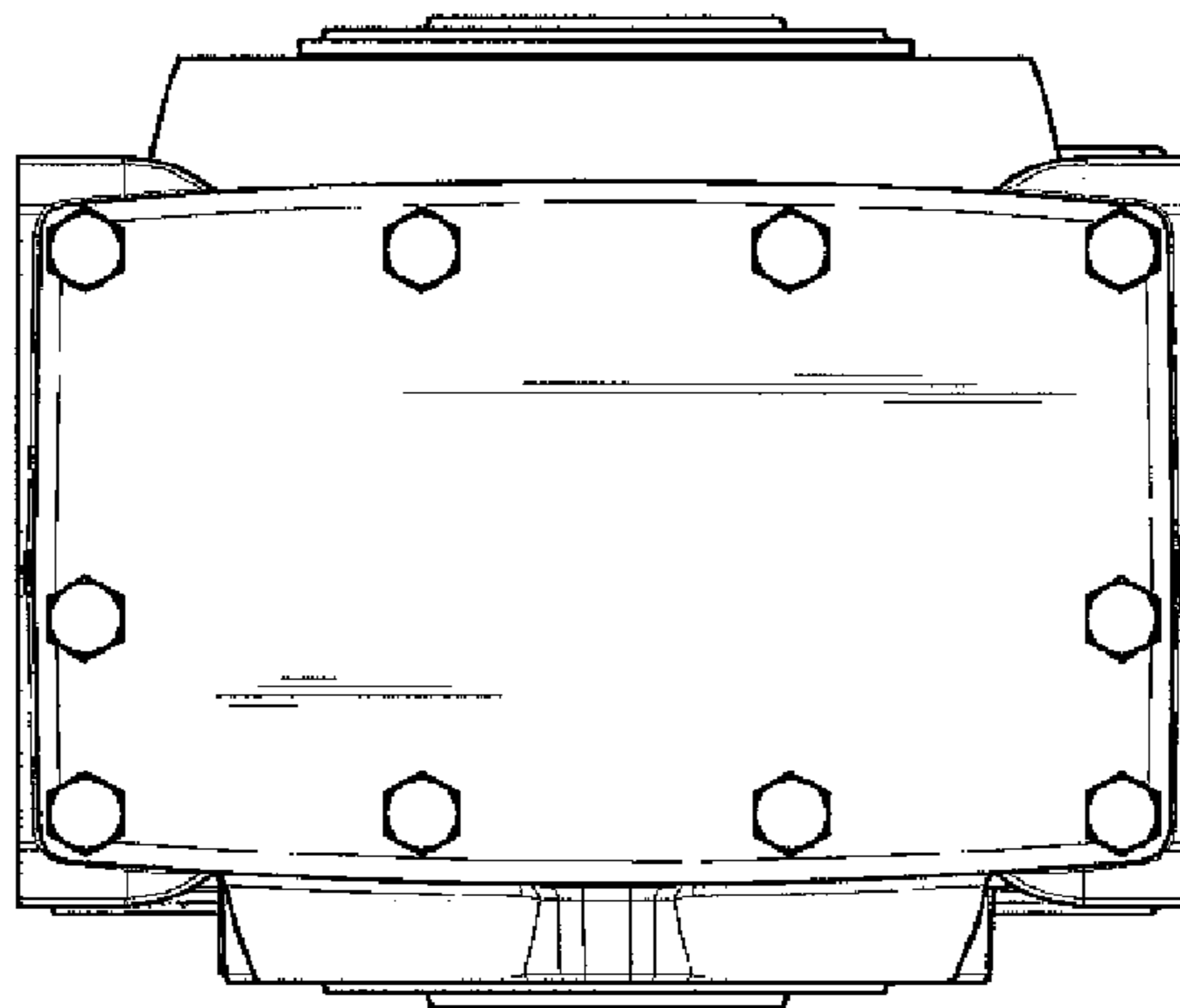

FIG 5

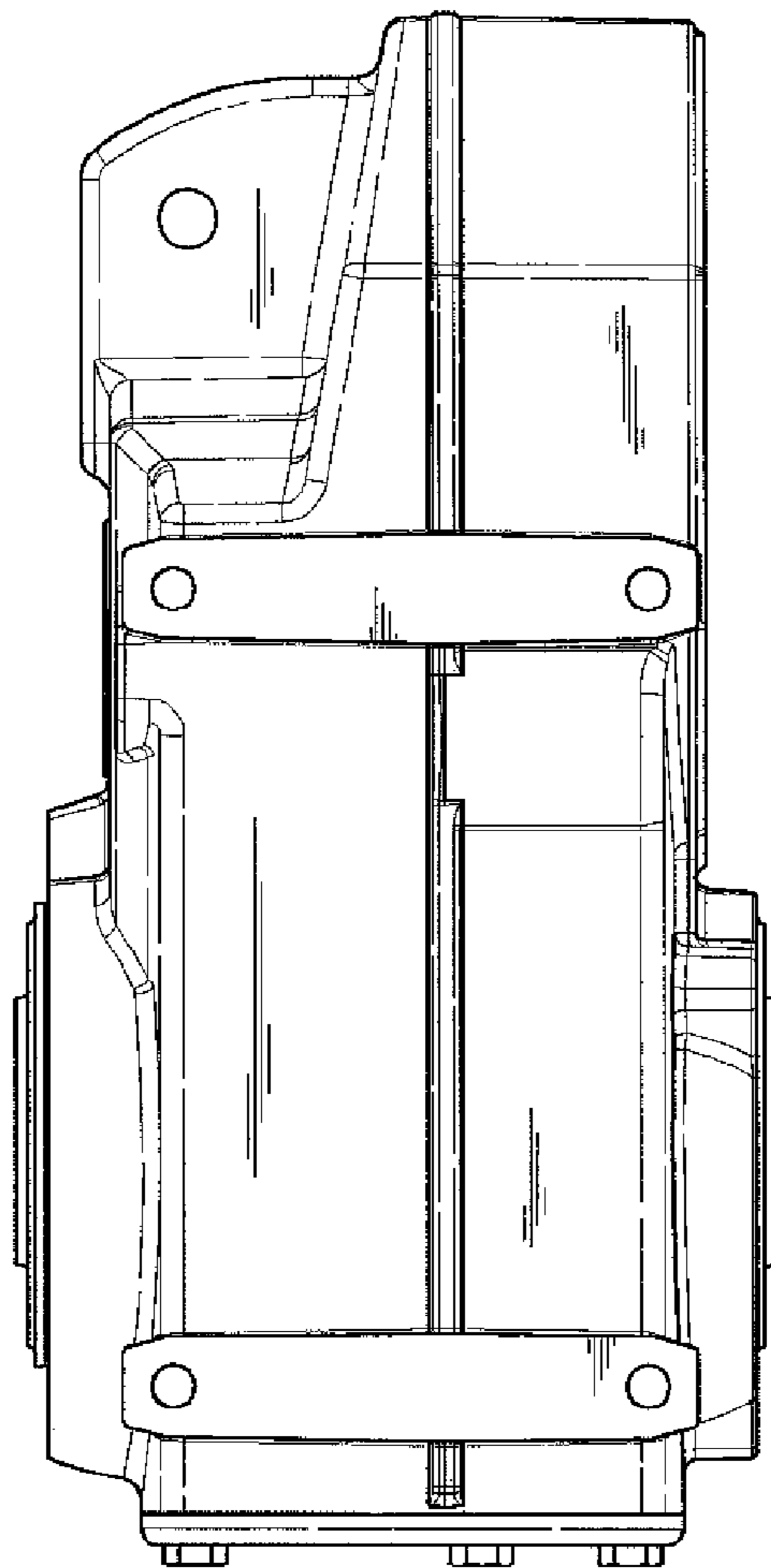

FIG 6

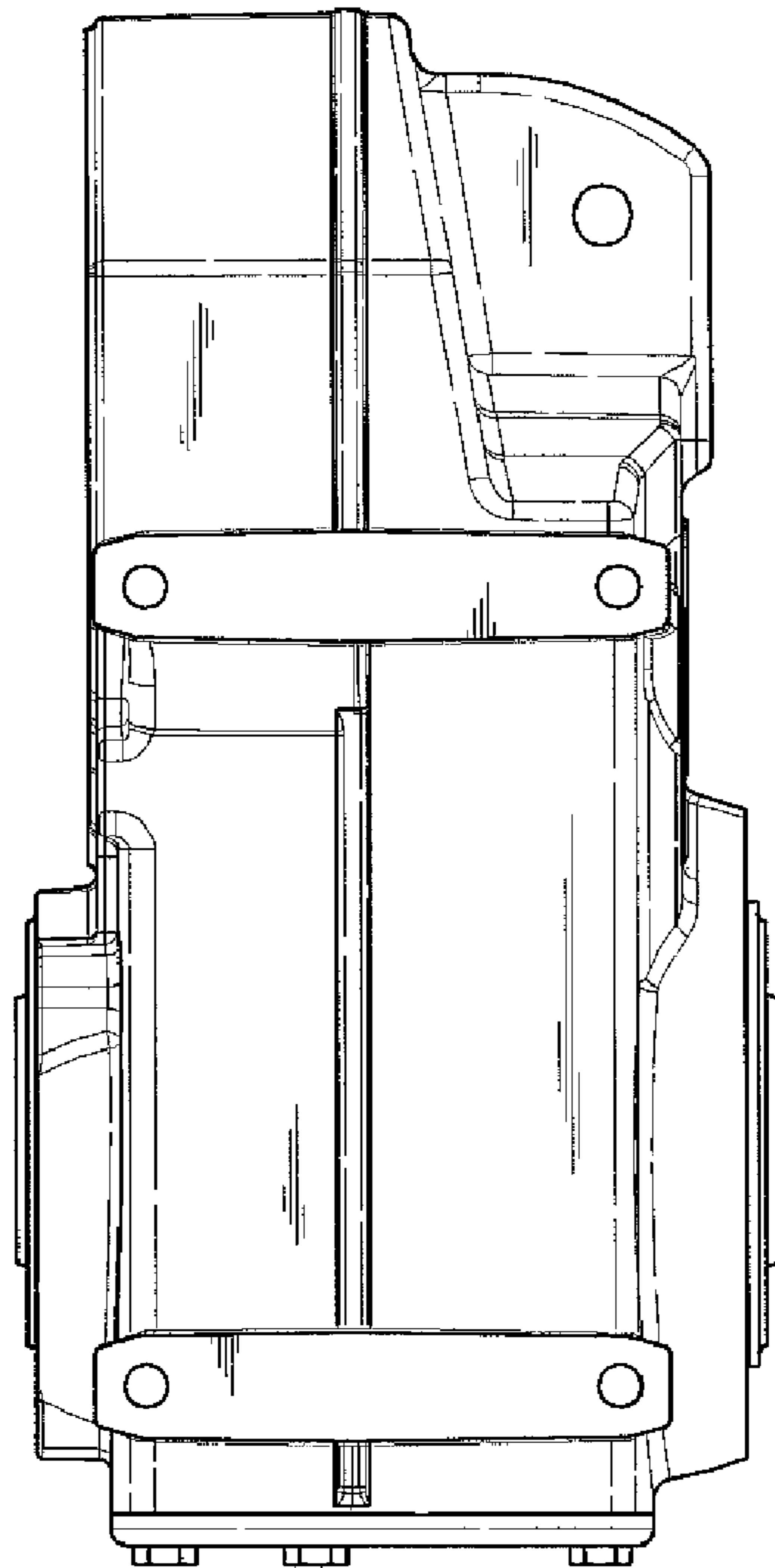

FIG 7

