



US00D674821S

(12) **United States Design Patent**  
**Budde**

(10) **Patent No.:** **US D674,821 S**  
(45) **Date of Patent:** **\*\* Jan. 22, 2013**

(54) **VEHICLE ROOF**

(75) Inventor: **Paul Budde**, Harsewinkel (DE)

(73) Assignee: **CLAAS KGaA mbH**, Harsewinkel (DE)

(\*\*) Term: **14 Years**

(21) Appl. No.: **29/424,925**

(22) Filed: **Jun. 18, 2012**

**Related U.S. Application Data**

(62) Division of application No. 29/402,635, filed on Sep. 26, 2011.

(30) **Foreign Application Priority Data**

Mar. 28, 2011 (EP) ..... 001841693

(51) **LOC (9) Cl.** ..... **15-03**

(52) **U.S. Cl.** ..... **D15/30**

(58) **Field of Classification Search** ..... D15/10,  
D15/22-26, 28, 30, 31; 180/89.11, 89.12,  
180/89.13, 89.19, 900; 296/190.01, 190.08,  
296/210, 190, 202

See application file for complete search history.

(56) **References Cited**

U.S. PATENT DOCUMENTS

D208,402	S	*	8/1967	Hofmann	.....	D15/30
D229,046	S	*	11/1973	Purcell et al.	.....	D15/30
3,802,530	A	*	4/1974	Purcell et al.	.....	180/89.12
RE29,123	E	*	1/1977	Malm et al.	.....	296/35.1
D249,522	S	*	9/1978	Elfes et al.	.....	D15/30
D275,199	S	*	8/1984	Schmidt et al.	.....	D15/30
D297,329	S	*	8/1988	Monehaie et al.	.....	D15/30
5,413,188	A	*	5/1995	Ui	.....	180/89.12
D384,358	S	*	9/1997	Smith	.....	D15/30
D528,134	S	*	9/2006	Vandendriessche et al.	..	D15/30
D541,825	S	*	5/2007	Pettersson	.....	D15/30
7,347,488	B2	*	3/2008	Hayes et al.	.....	296/190.08

\* cited by examiner

*Primary Examiner* — Mark Goodwin

(74) *Attorney, Agent, or Firm* — Michael J. Striker

(57) **CLAIM**

The ornamental design for a vehicle roof, as shown and described.

**DESCRIPTION**

FIG. 1 is a top front perspective view of a vehicle roof showing my new design;  
FIG. 2 is a top rear perspective view thereof;  
FIG. 3 is a front view thereof;  
FIG. 4 is a back view thereof;  
FIG. 5 is a left side view thereof;  
FIG. 6 is a right side view thereof; and,  
FIG. 7 is a top plan view thereof.

**1 Claim, 7 Drawing Sheets**

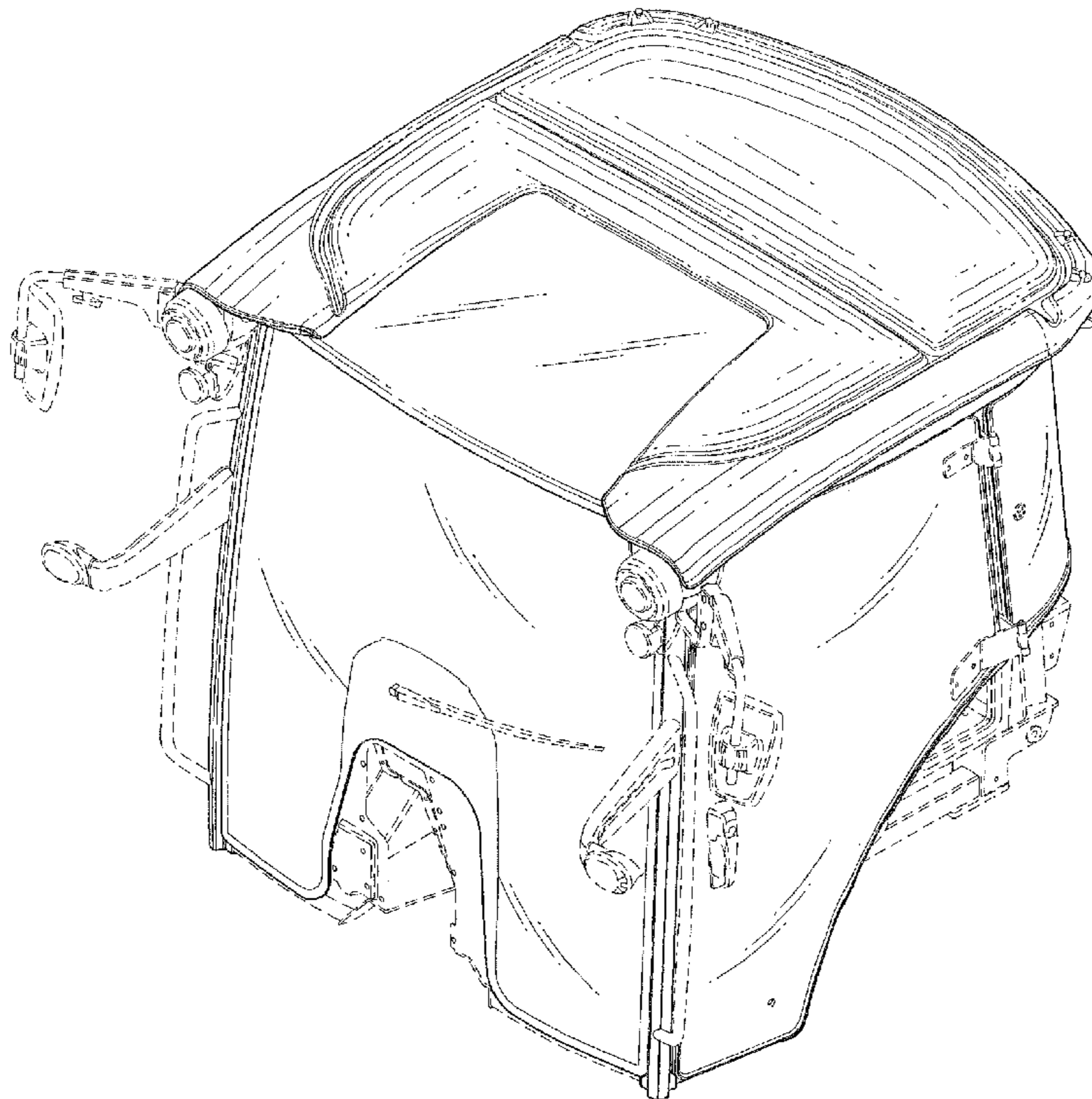

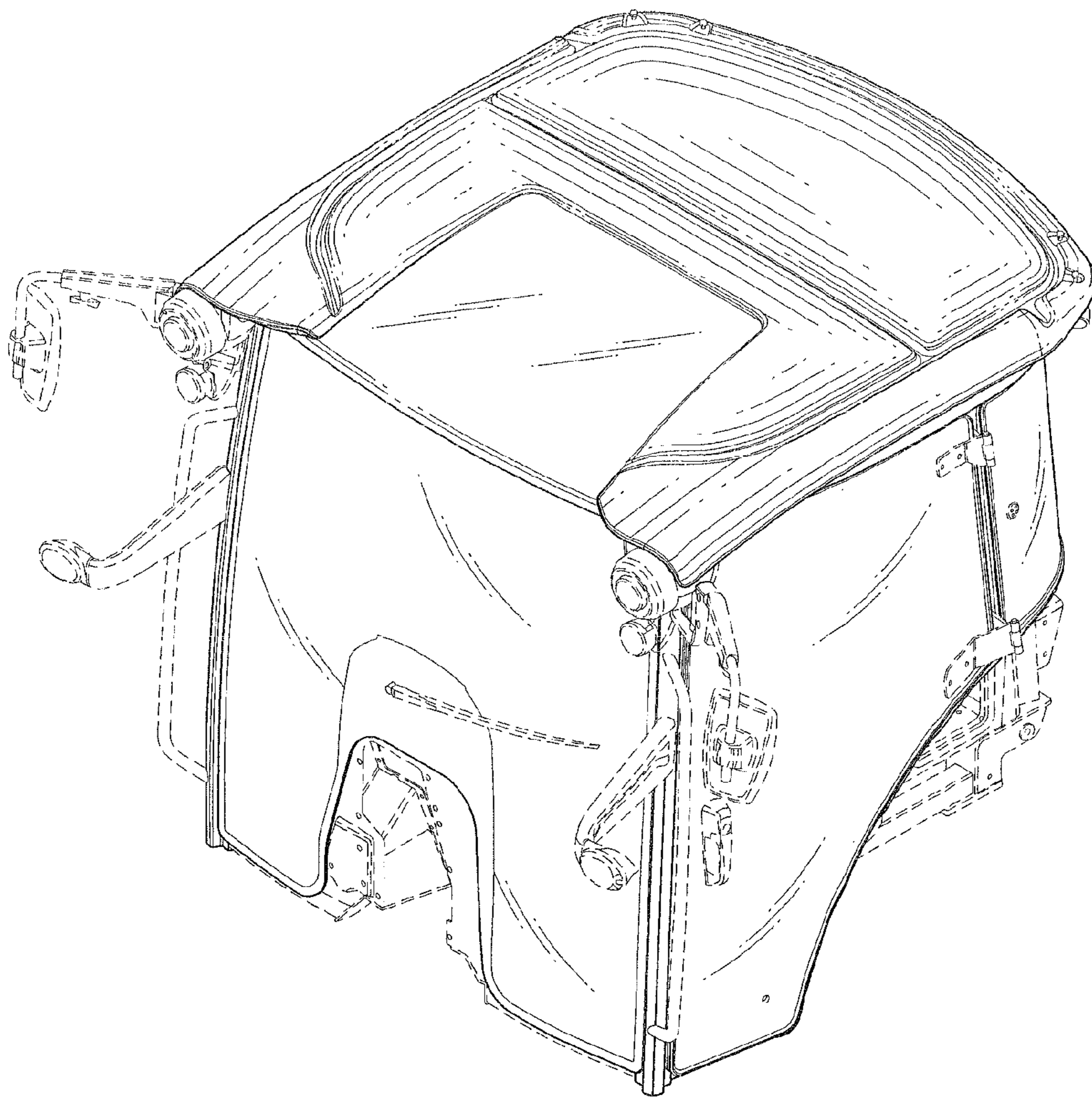

FIG. 1

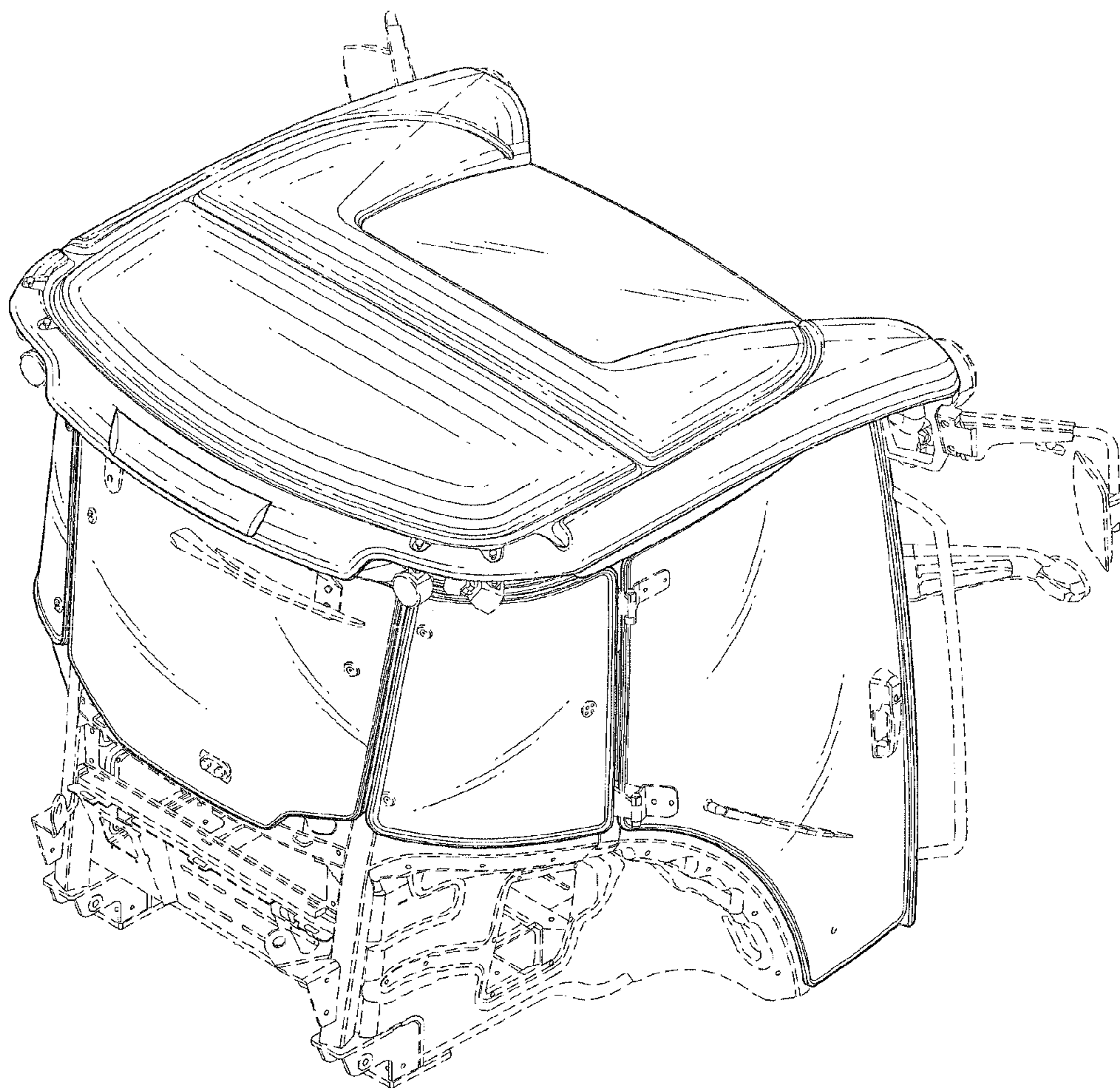

FIG. 2

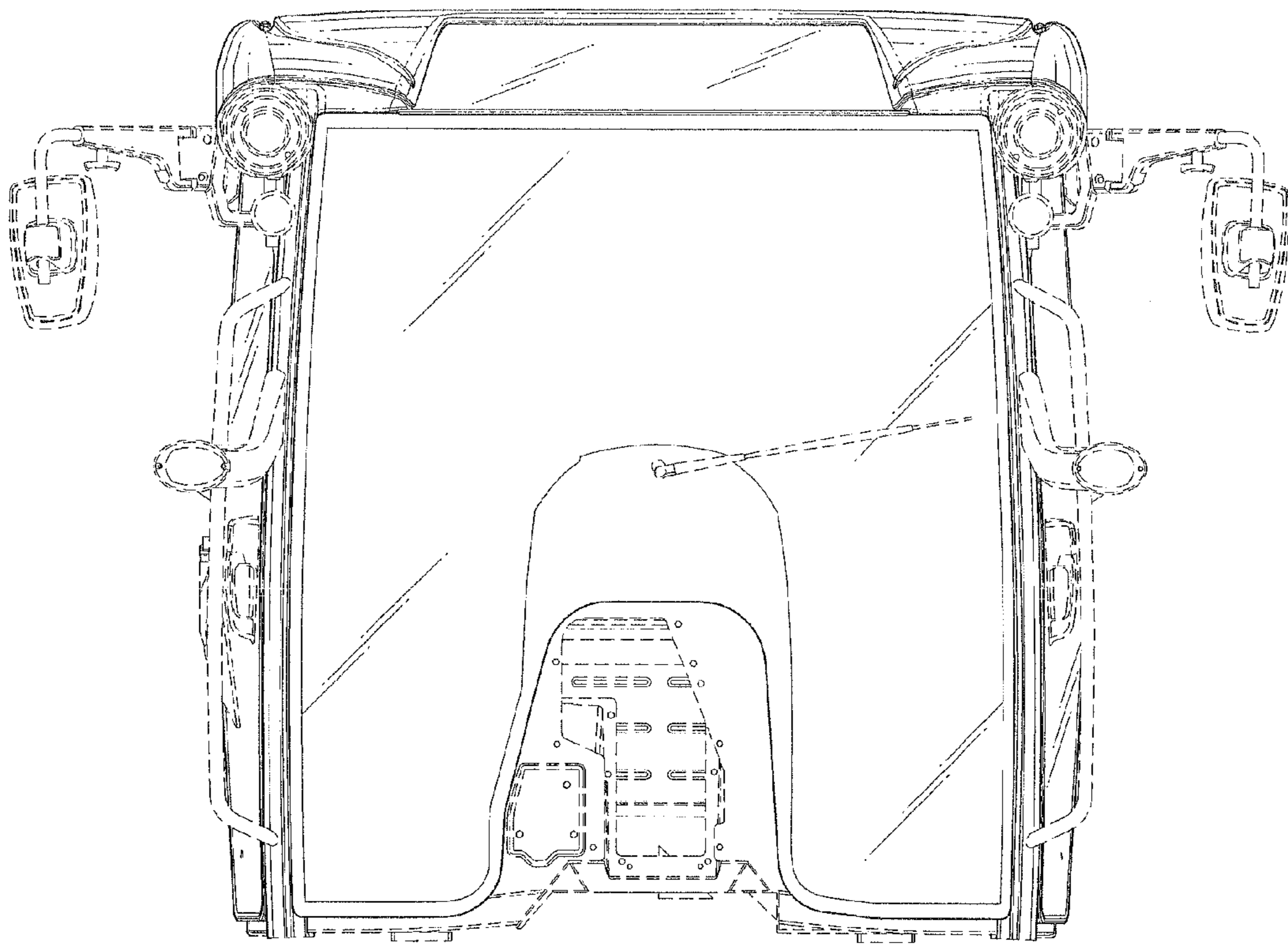

FIG. 3

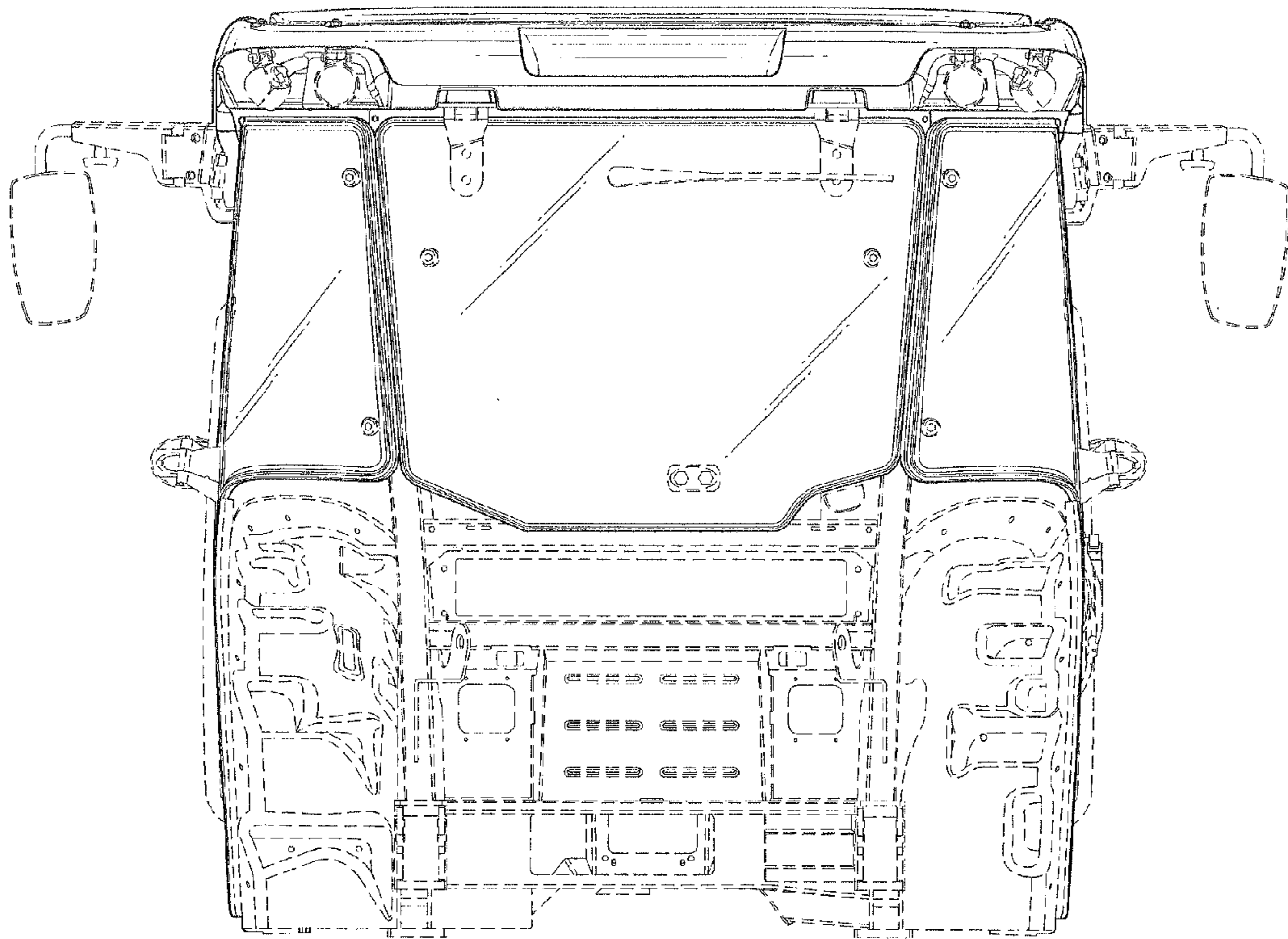

FIG. 4

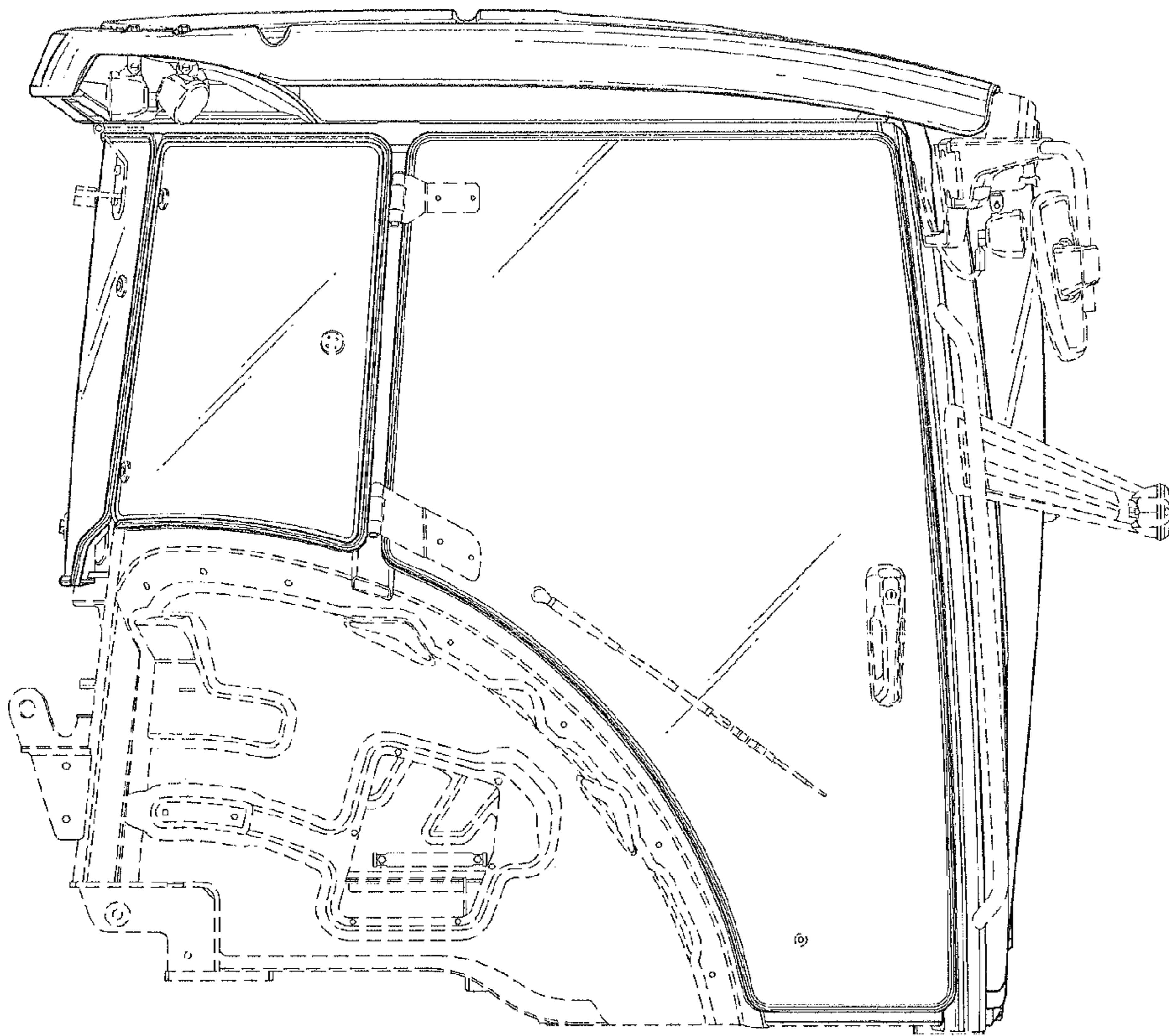

FIG. 5

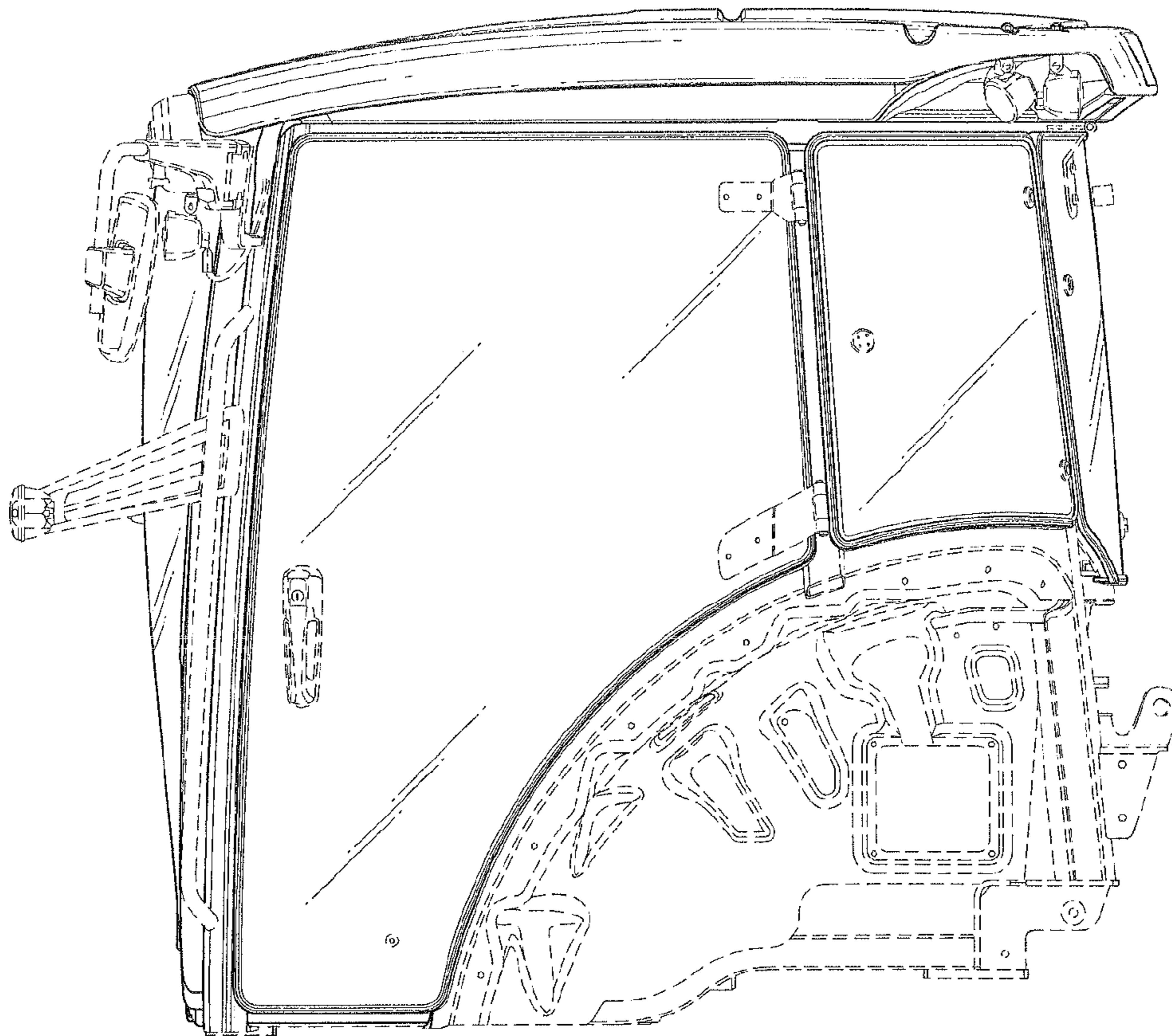

FIG. 6

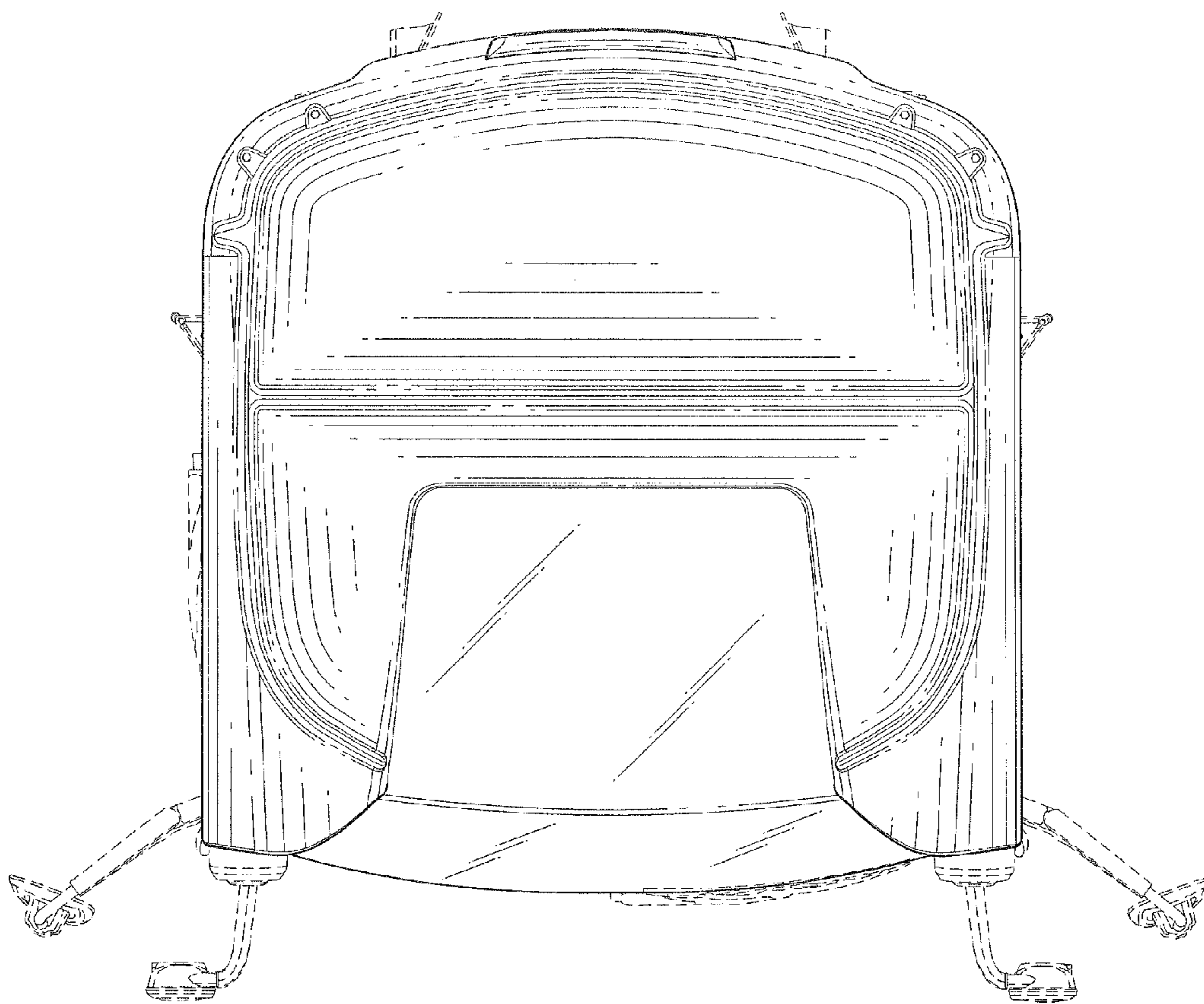

FIG. 7