



US00D674764S

(12) **United States Design Patent**
Suzuki

(10) **Patent No.:** **US D674,764 S**

(45) **Date of Patent:** **** Jan. 22, 2013**

(54) **AMPLIFIER FOR GUITAR**

(75) Inventor: **Toshihide Suzuki**, Hamamatsu (JP)

(73) Assignee: **Yamaha Corporation**, Shizuoka (JP)

(**) Term: **14 Years**

(21) Appl. No.: **29/414,564**

(22) Filed: **Feb. 29, 2012**

(30) **Foreign Application Priority Data**

Aug. 29, 2011 (JP) 2011-019446
Aug. 29, 2011 (JP) 2011-019448

(51) **LOC (9) Cl.** **14-03**

(52) **U.S. Cl.** **D14/188**

(58) **Field of Classification Search** D14/168,
D14/169, 179, 188, 194-198, 215, 217, 257,
D14/265, 299, 496; 330/1 R, 3, 4, 250; 381/86,
381/120; 455/344-351

See application file for complete search history.

(56) **References Cited**

U.S. PATENT DOCUMENTS

D237,089 S * 10/1975 Walker D14/196
D478,564 S * 8/2003 Rizzi D14/188
D495,012 S * 8/2004 Morimoto D14/188
D546,814 S * 7/2007 Takita et al. D14/168
D582,391 S * 12/2008 Morimoto D14/214
D636,374 S * 4/2011 Smith D14/188

OTHER PUBLICATIONS

Massia68, "Yamaha THR 5 Guitar Buzz Issue & Amp Review (Viral)", <http://www.youtube.com/watch?v=FyjOHbY5TL0>,

YouTube video, dated Nov. 19, 2011, accessed Sep. 9, 2012, 1pg. (screenshot).*

* cited by examiner

Primary Examiner — Keli L Hill

(74) *Attorney, Agent, or Firm* — Sughrue Mion, PLLC

(57) **CLAIM**

The ornamental design for an amplifier for a guitar, as shown and described.

DESCRIPTION

FIG. 1 is a perspective view of the front, top and right side of an amplifier for a guitar according to a first embodiment showing my new design;

FIG. 2 is a front view thereof;

FIG. 3 is a rear view thereof;

FIG. 4 is a left side view thereof;

FIG. 5 is a right side view thereof;

FIG. 6 is a top plan view thereof;

FIG. 7 is a bottom view thereof;

FIG. 8 is a perspective view of the front, top and right side of an amplifier for a guitar according to a second embodiment showing my new design;

FIG. 9 is a front view thereof;

FIG. 10 is a rear view thereof;

FIG. 11 is a left side view thereof;

FIG. 12 is a right side view thereof

FIG. 13 is a top plan view thereof; and,

FIG. 14 is a bottom view thereof.

The broken line showing of the amplifier for a guitar is included for the purpose of illustrating portions of the amplifier for a guitar and forms no part of the claimed design.

1 Claim, 12 Drawing Sheets

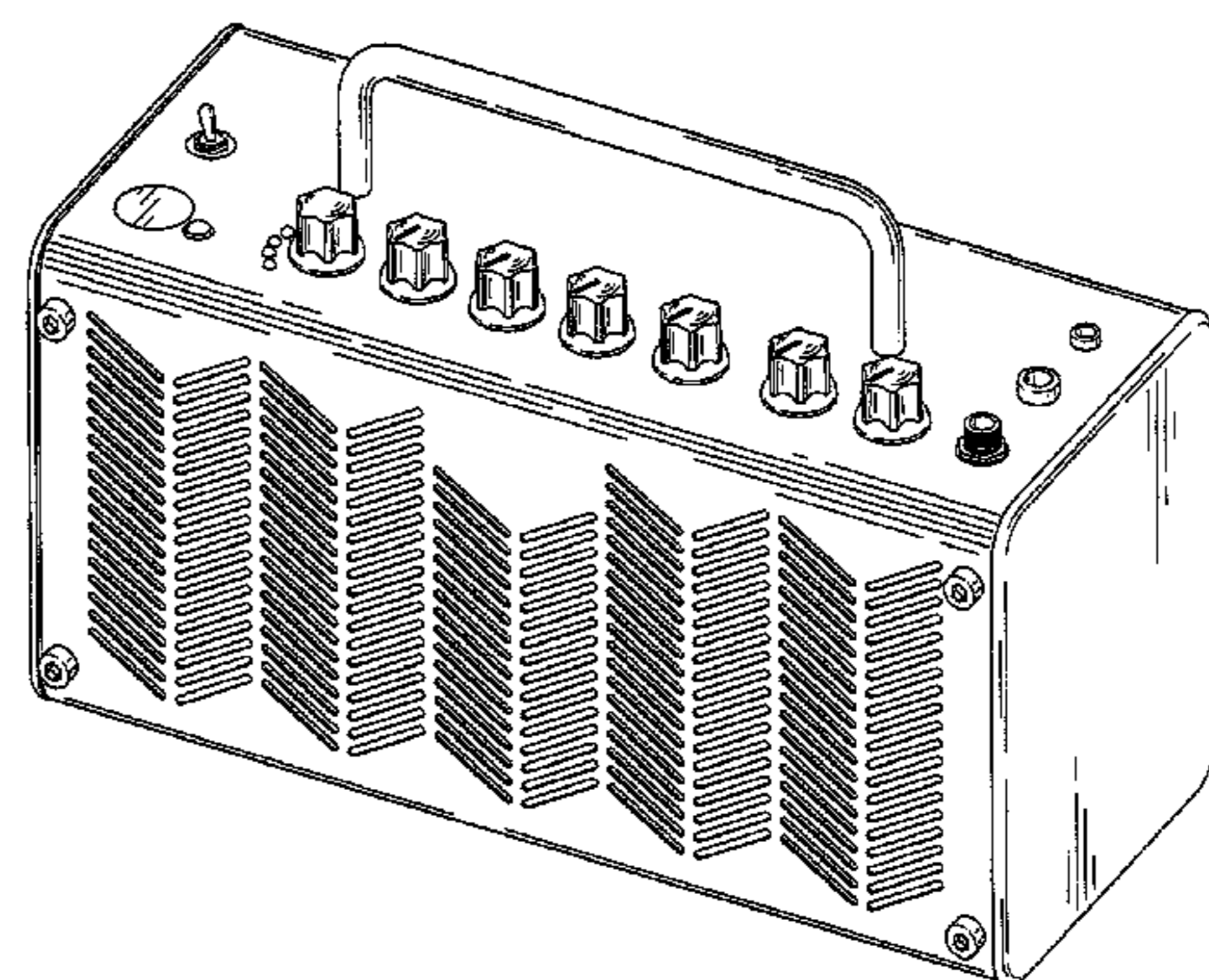
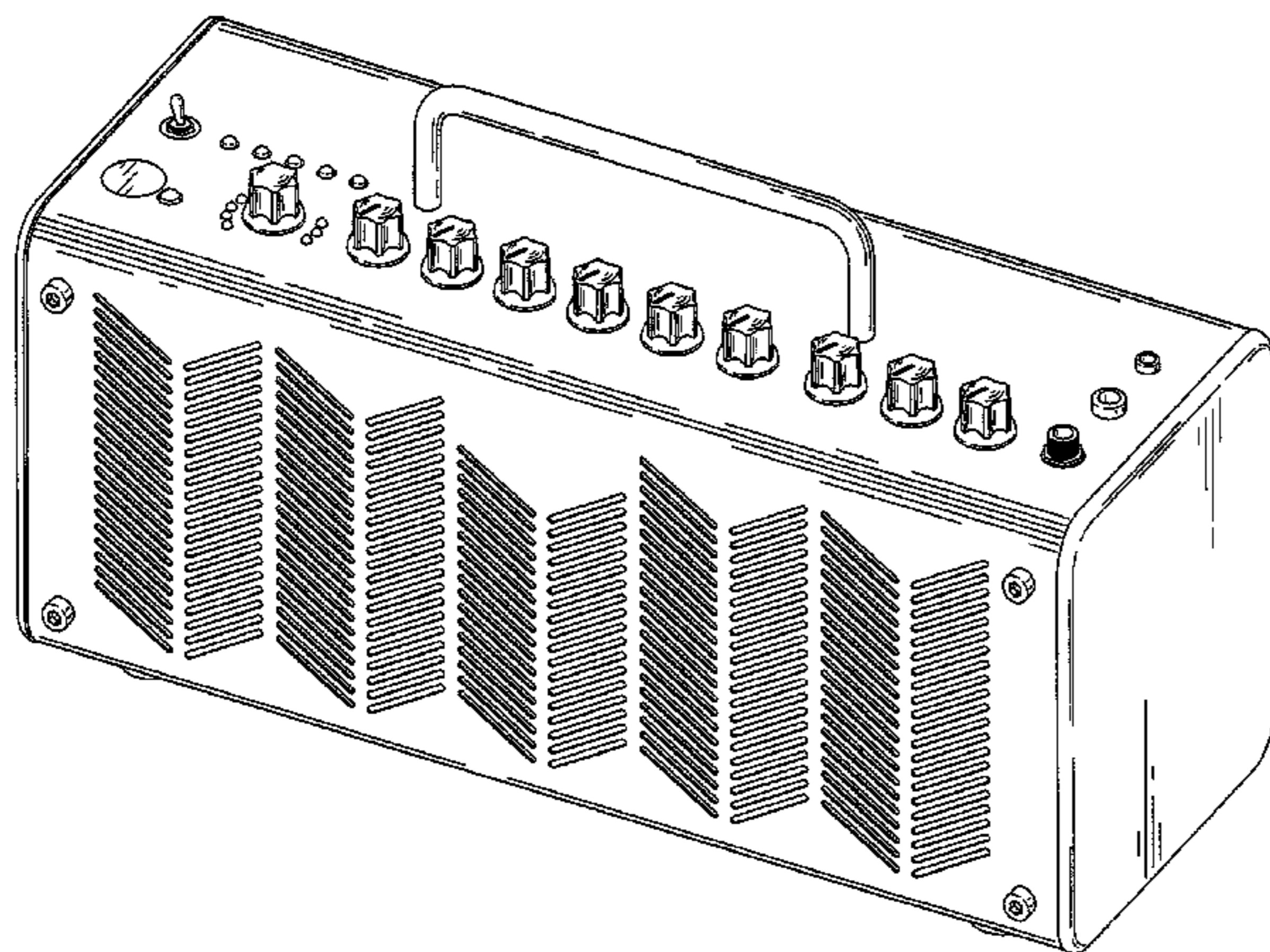

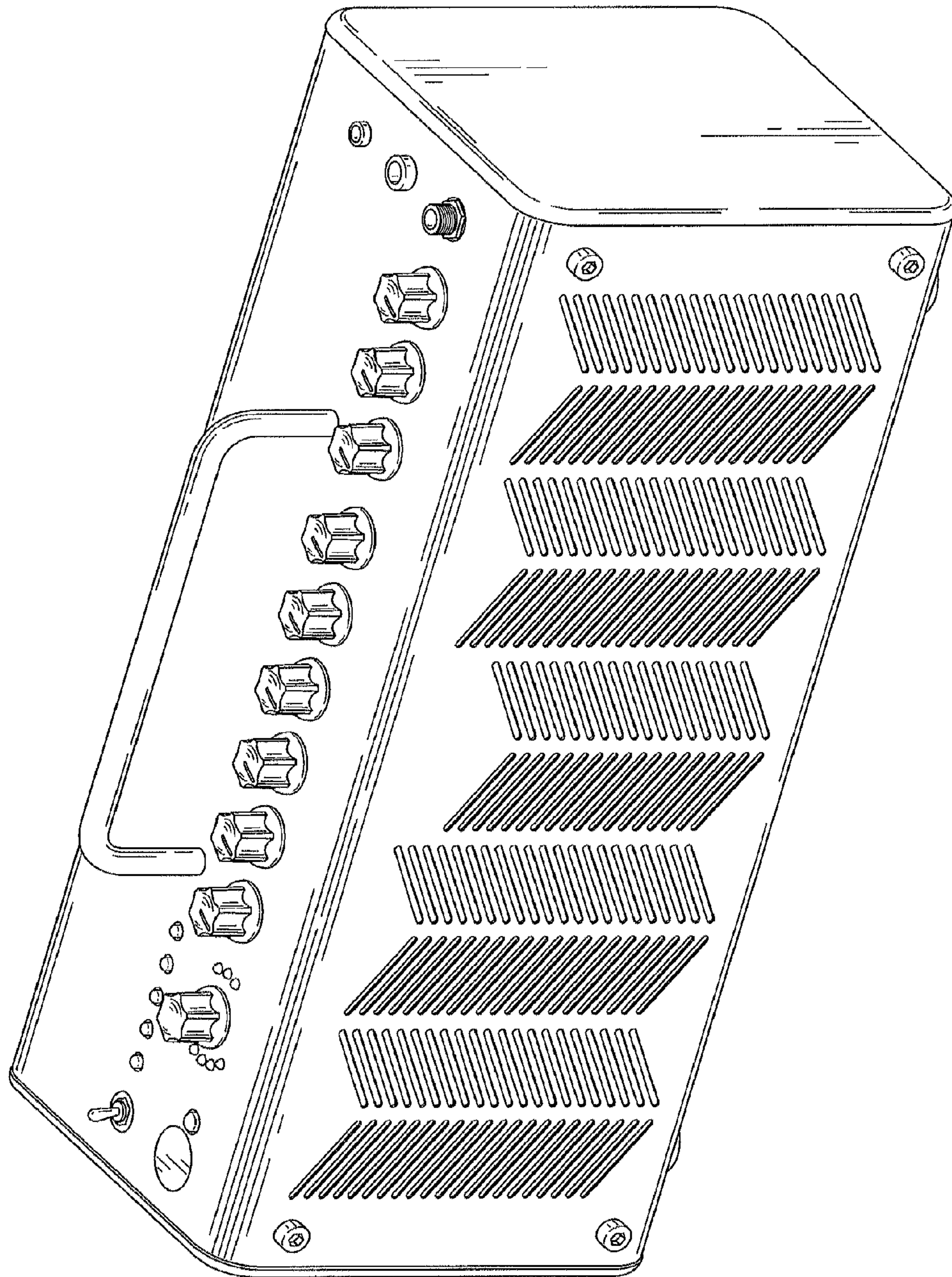

FIG. 1

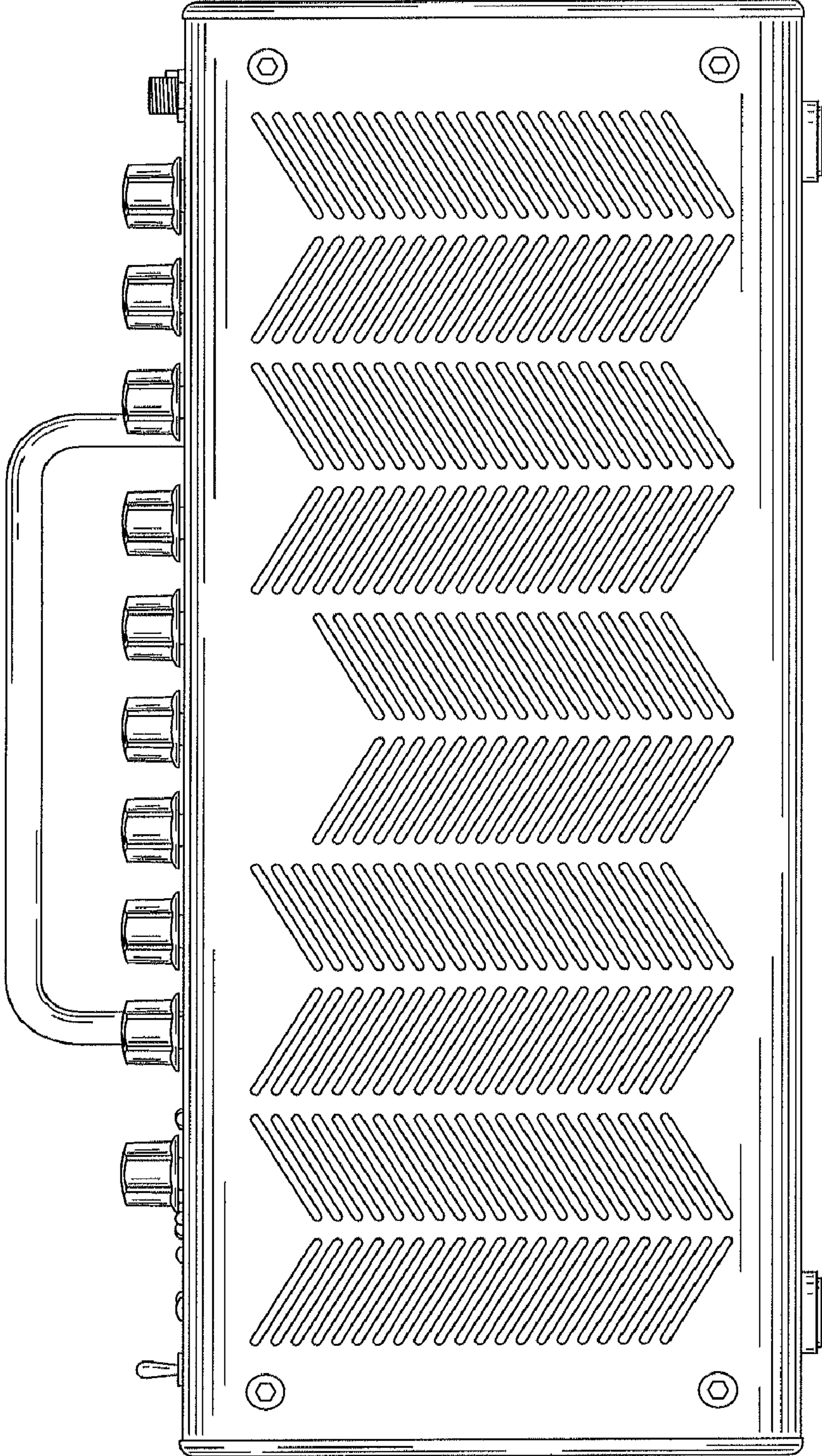

FIG. 2

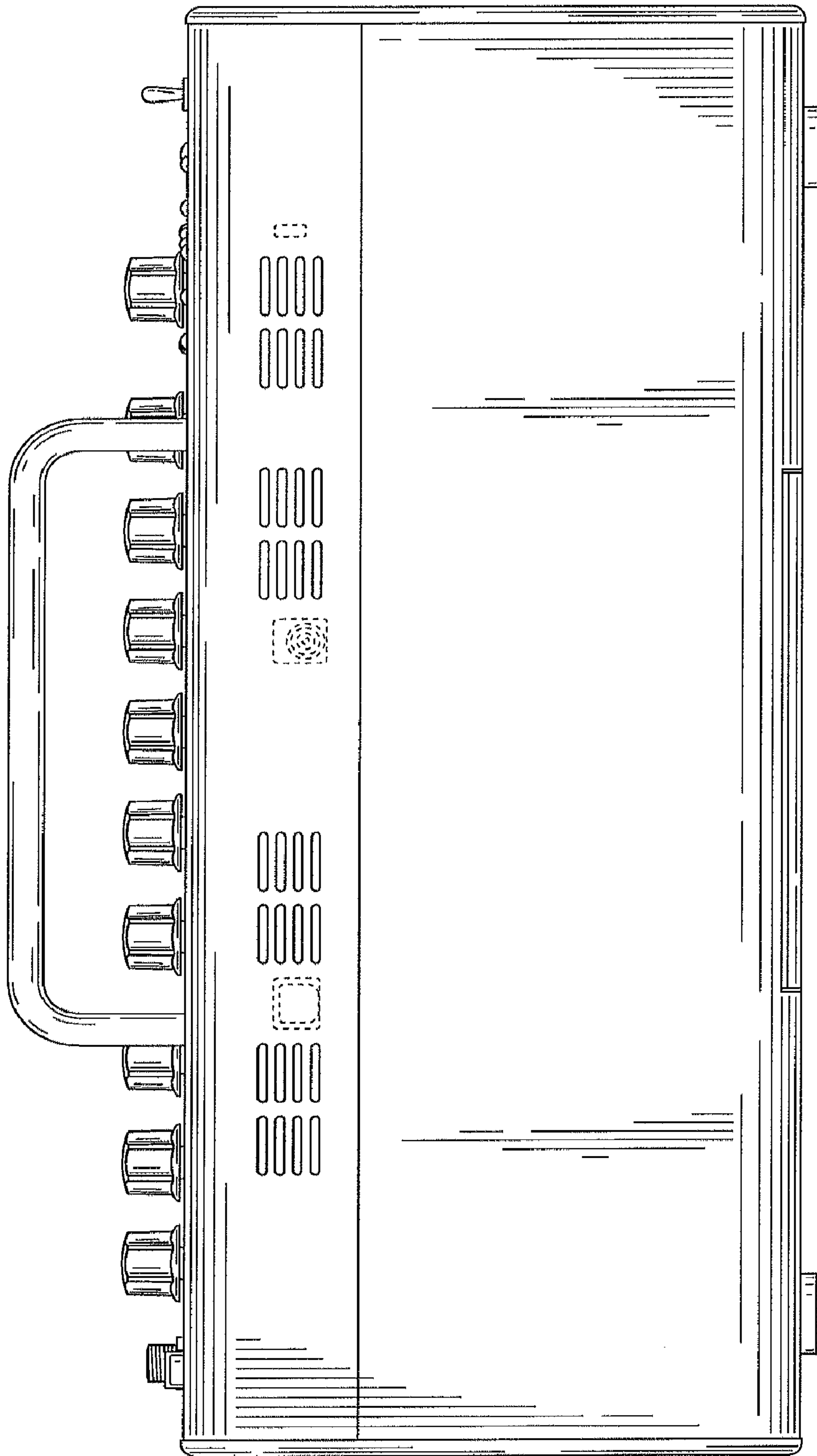

FIG. 3

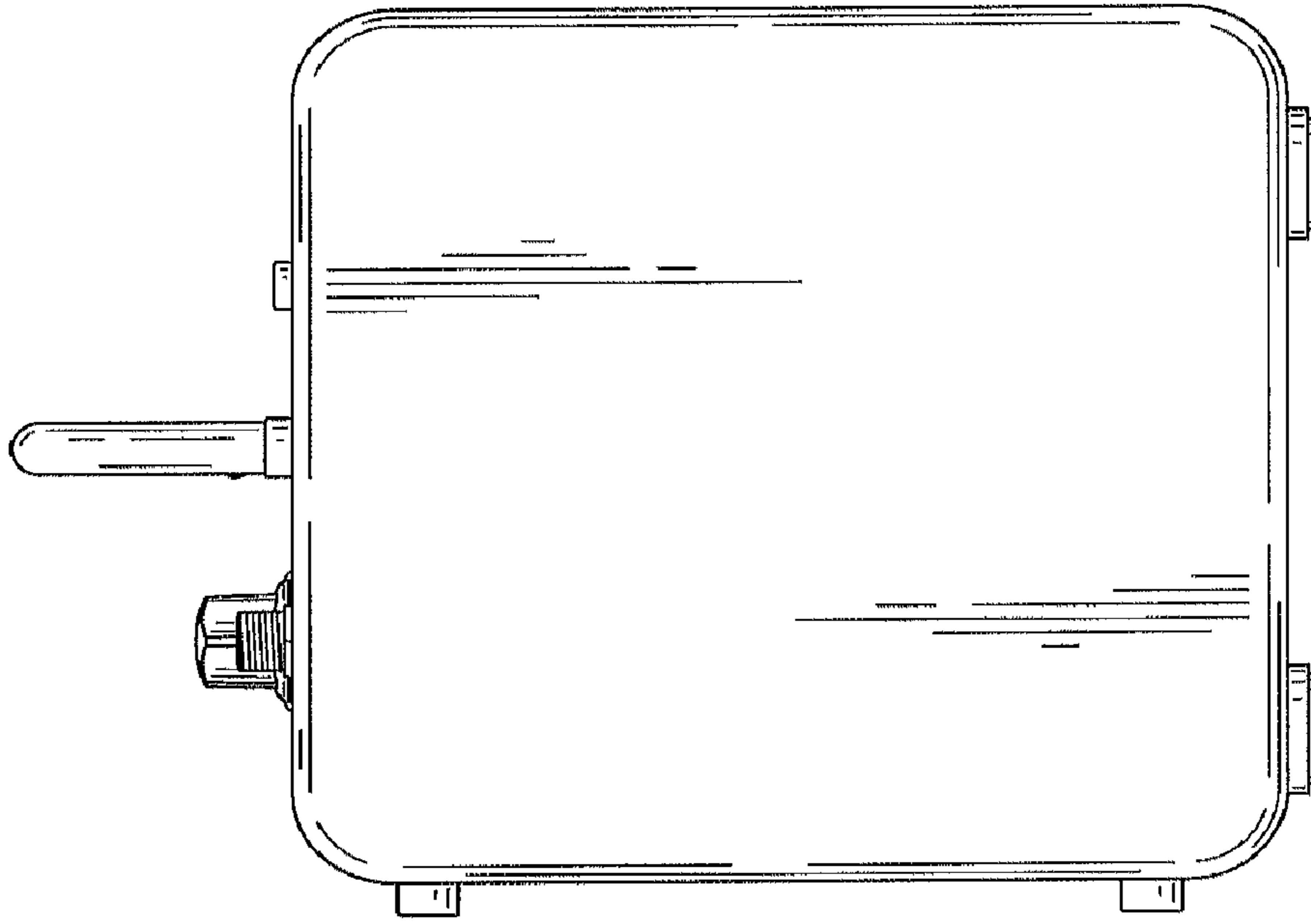

FIG. 4

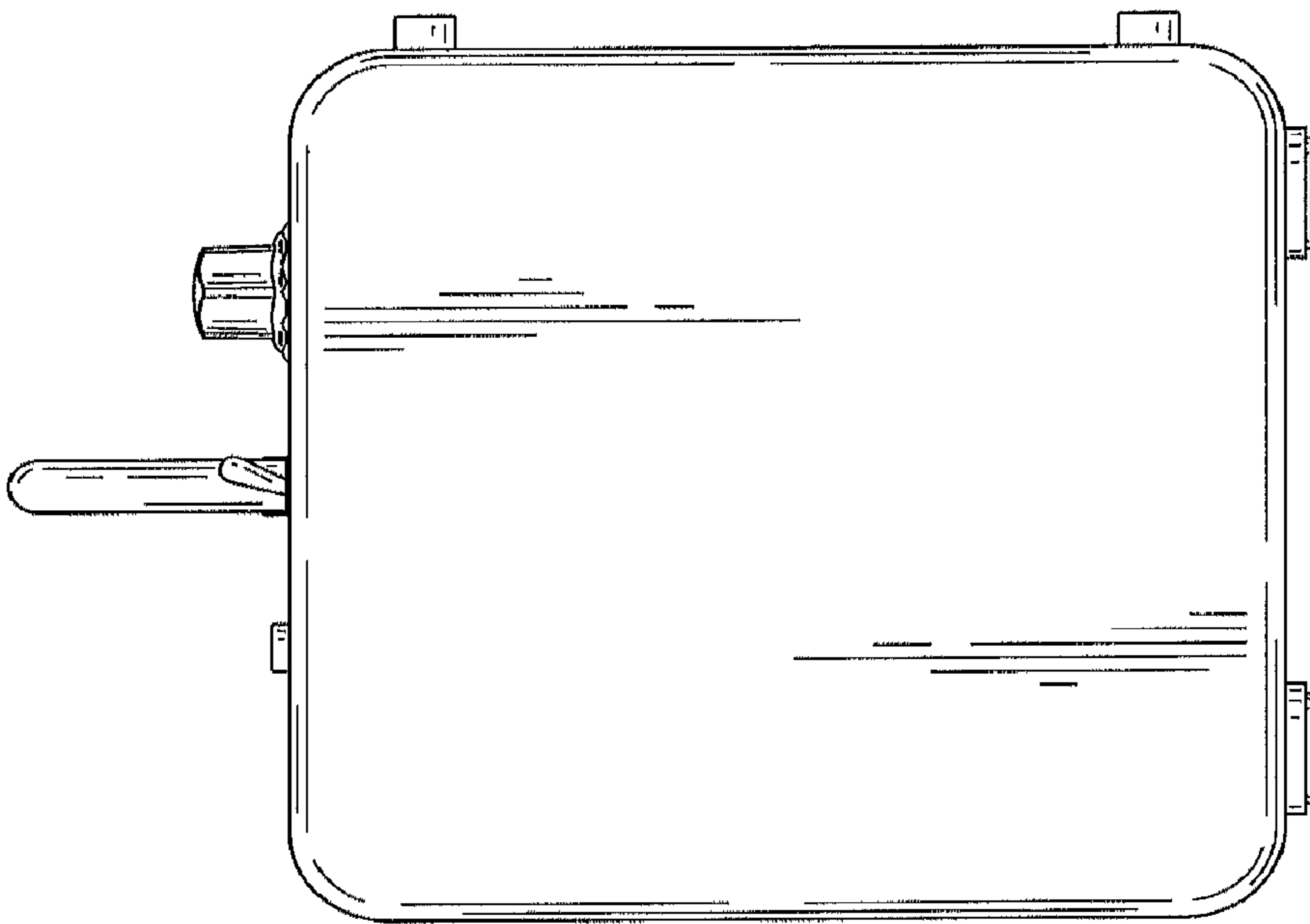

FIG. 5

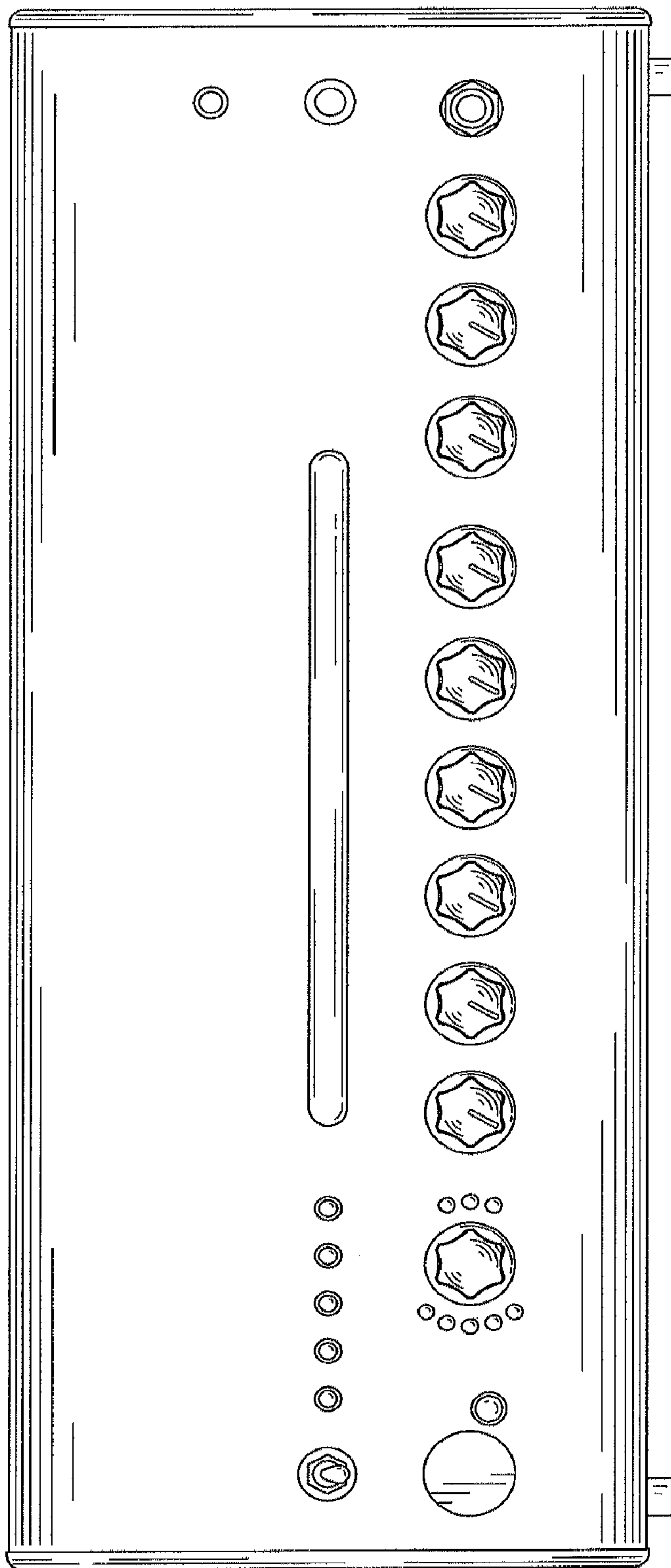

FIG. 6

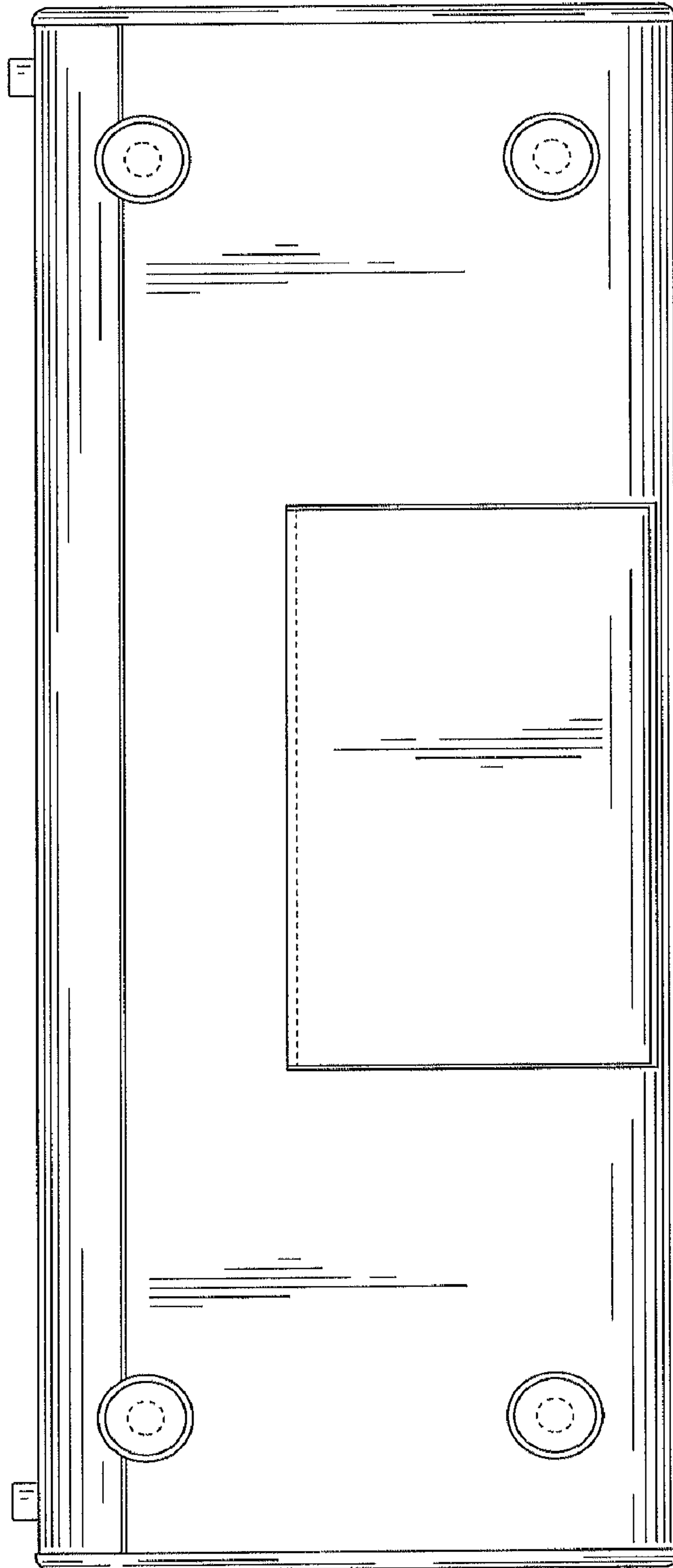

FIG. 7

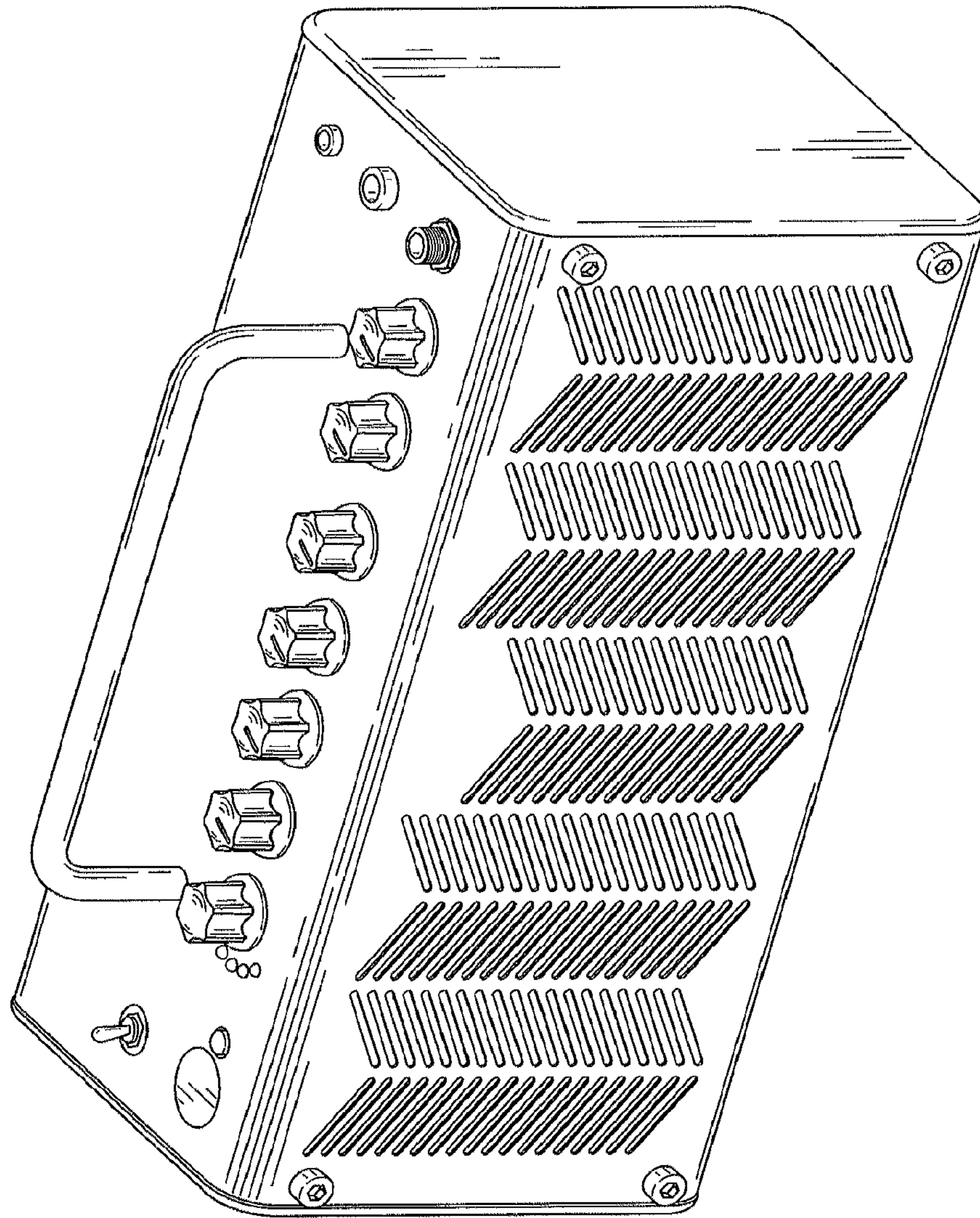

FIG. 8

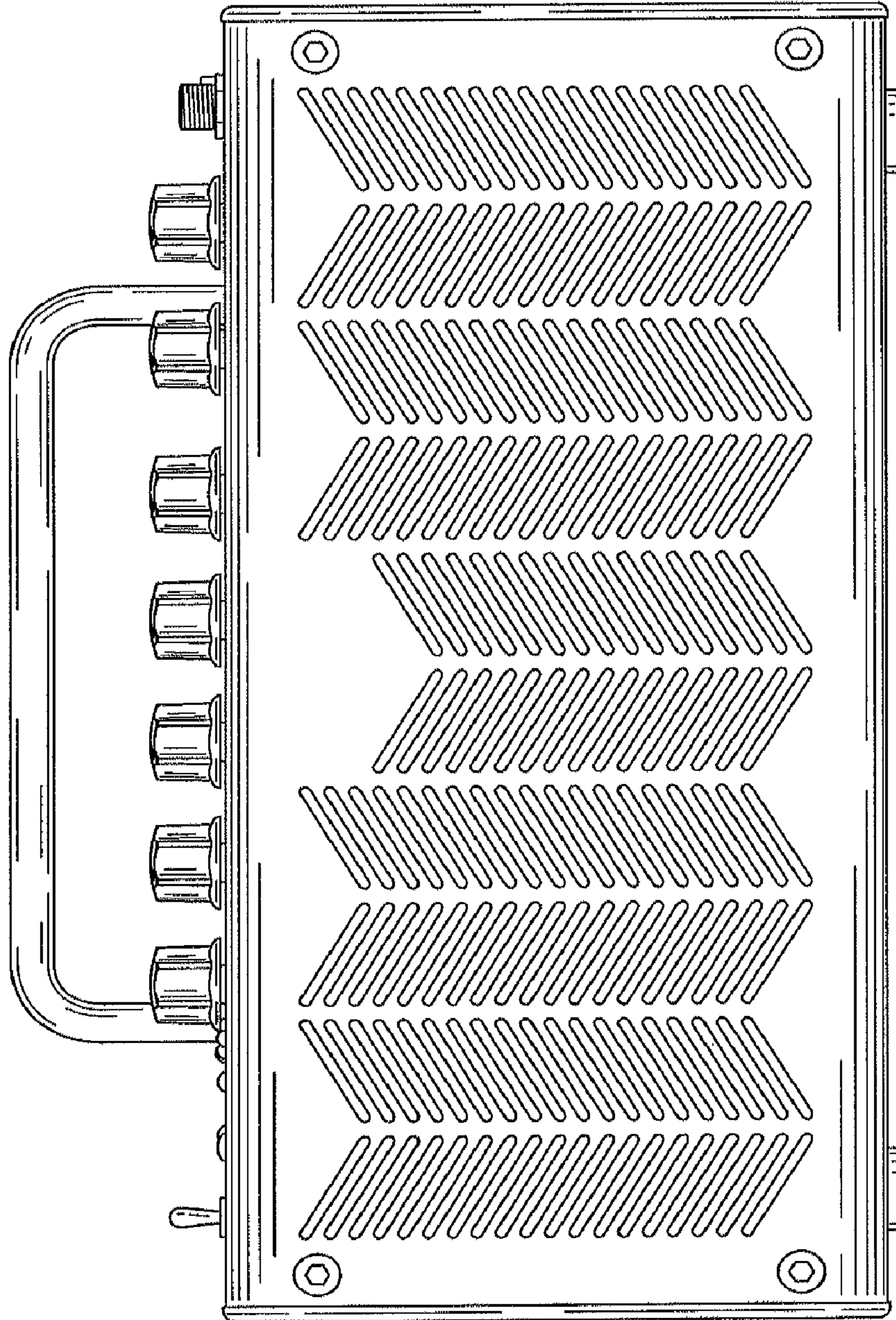

FIG. 9

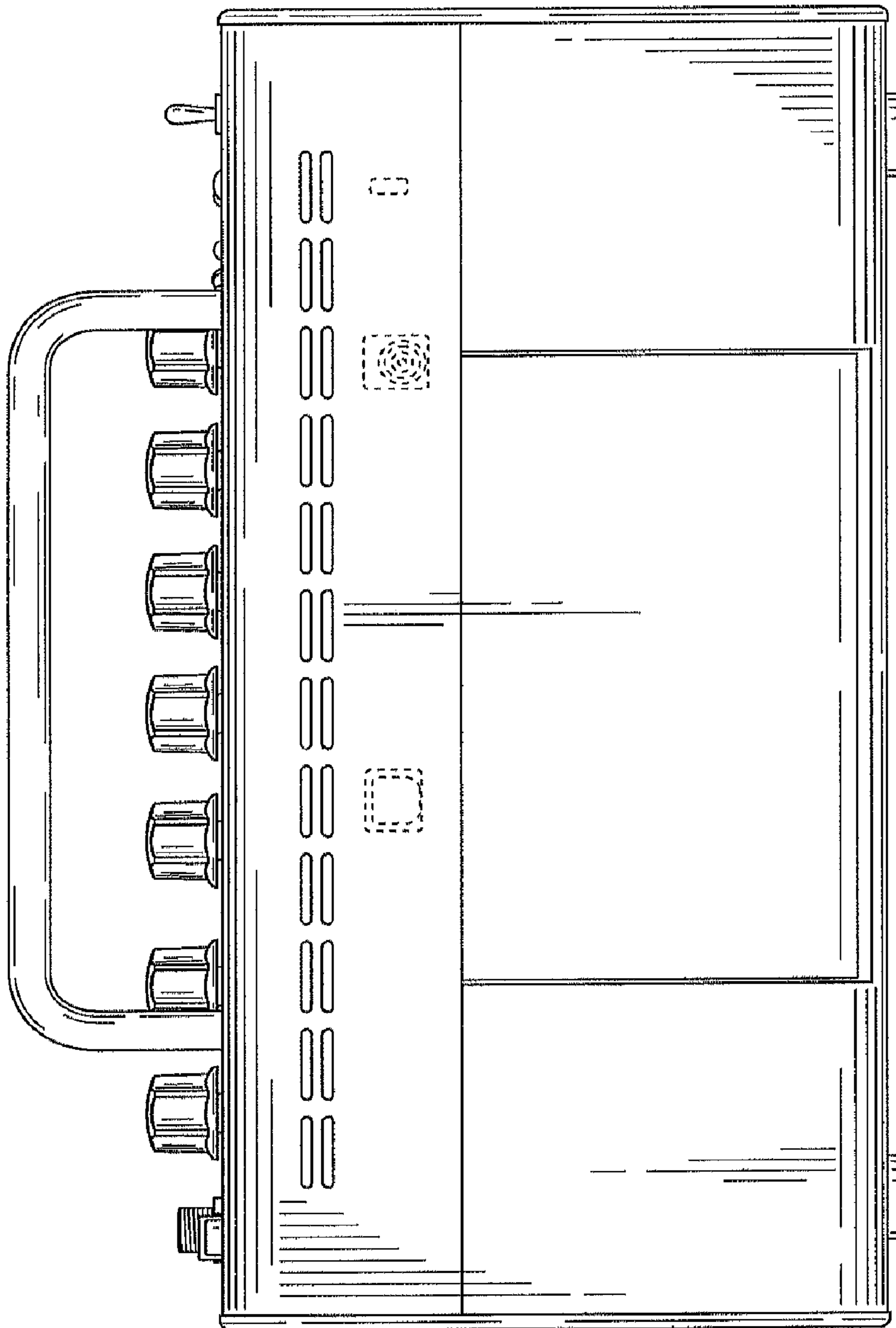

FIG. 10

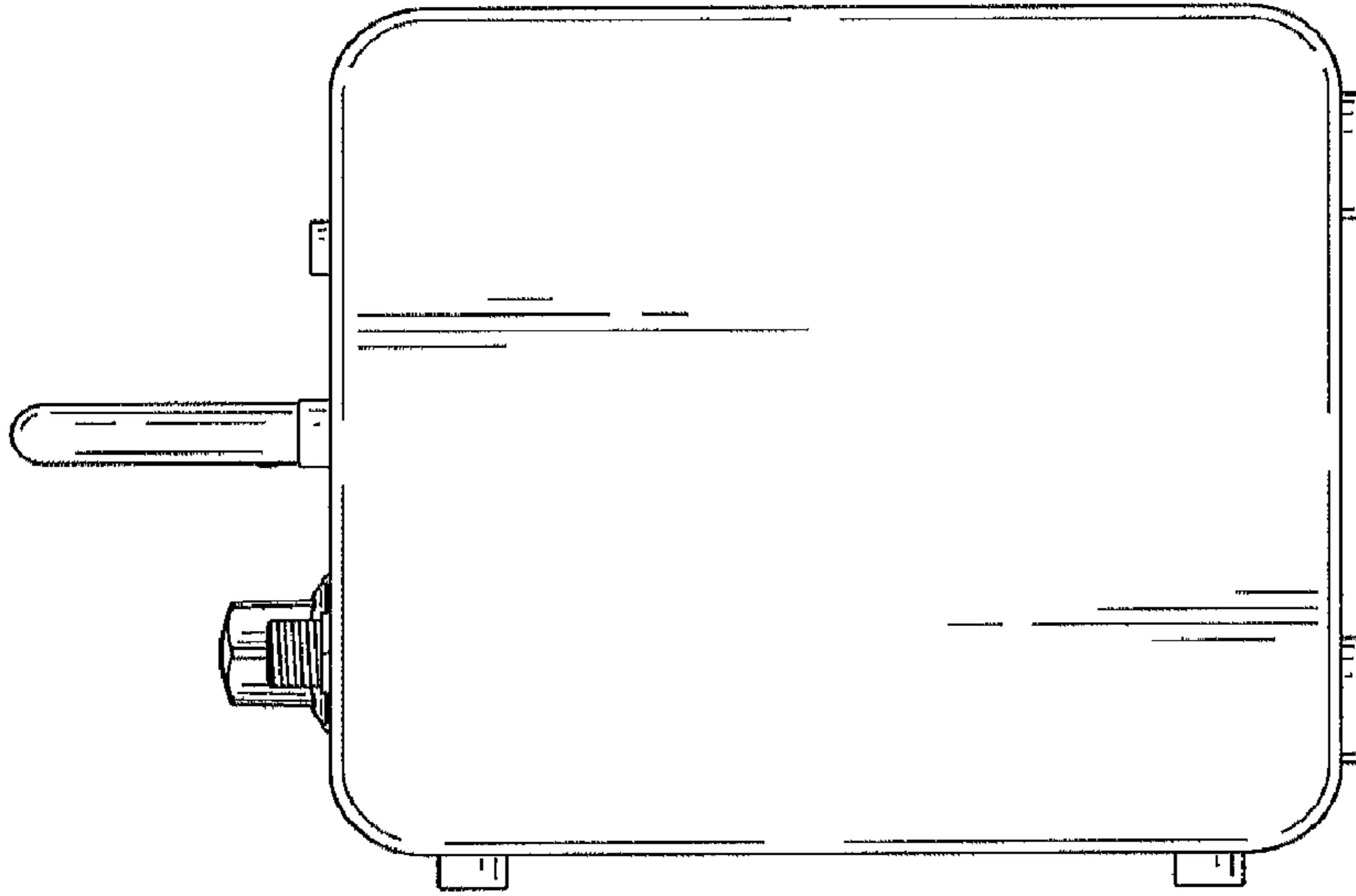

FIG. 11

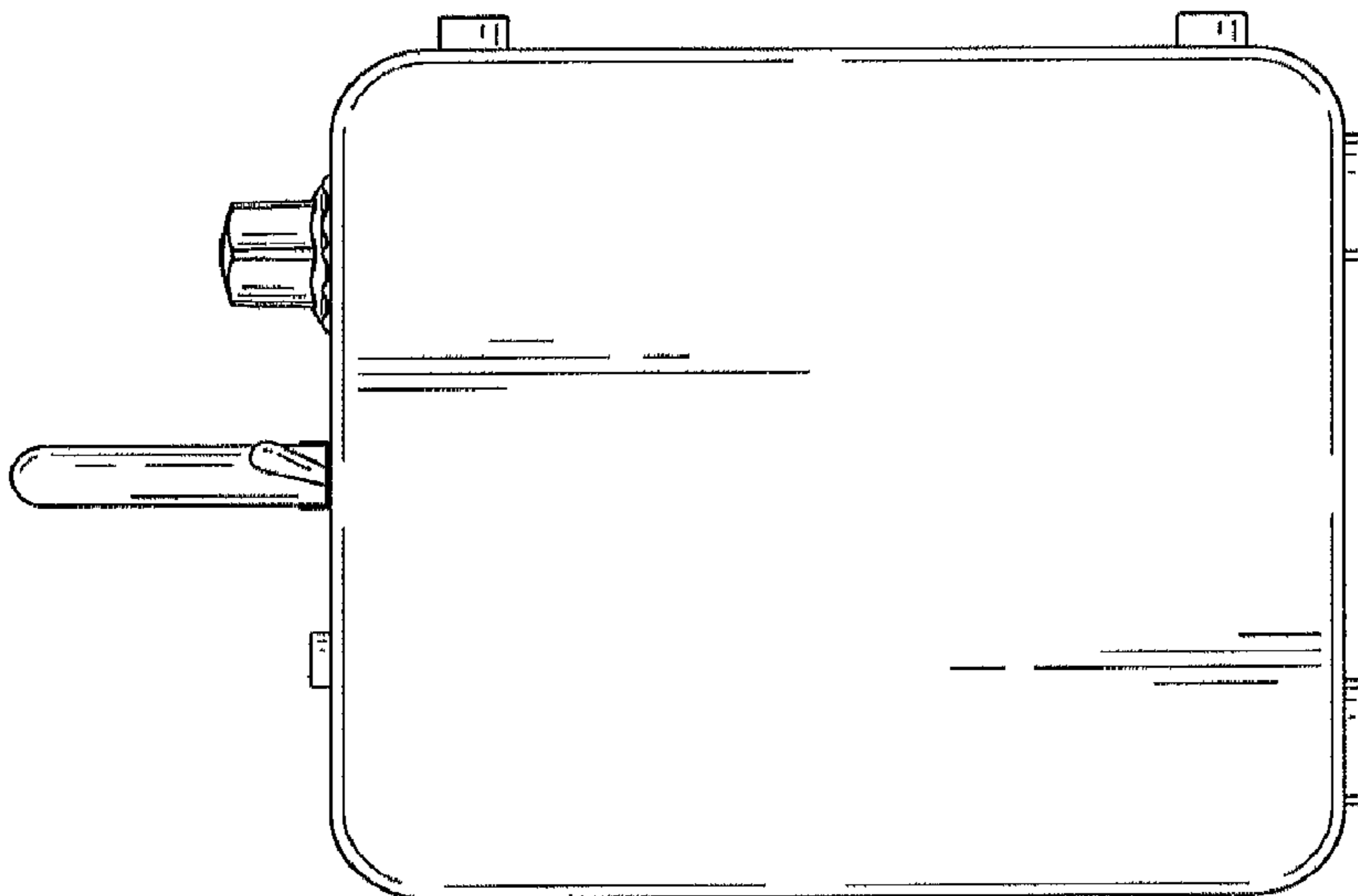

FIG. 12

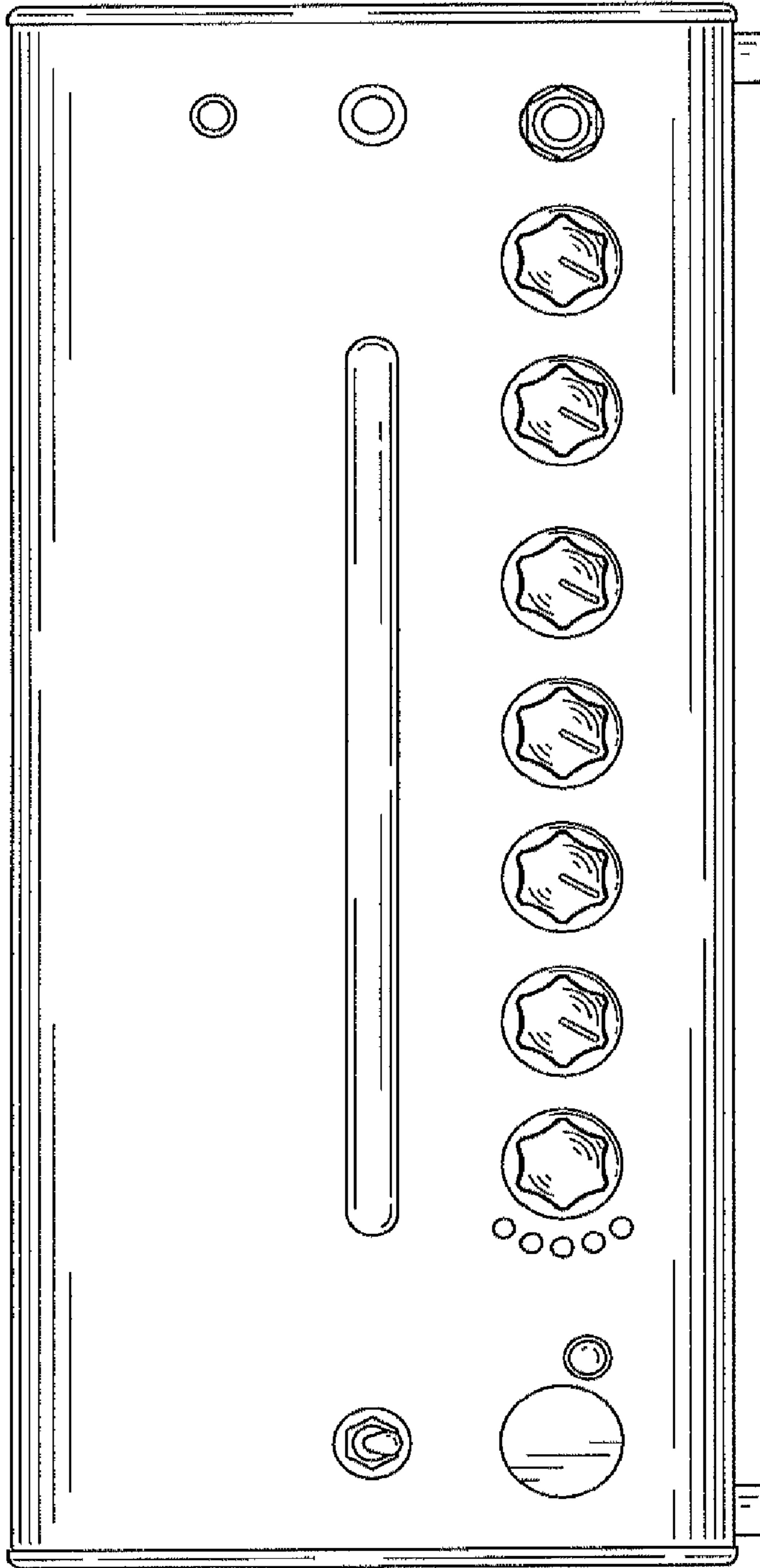

FIG. 13

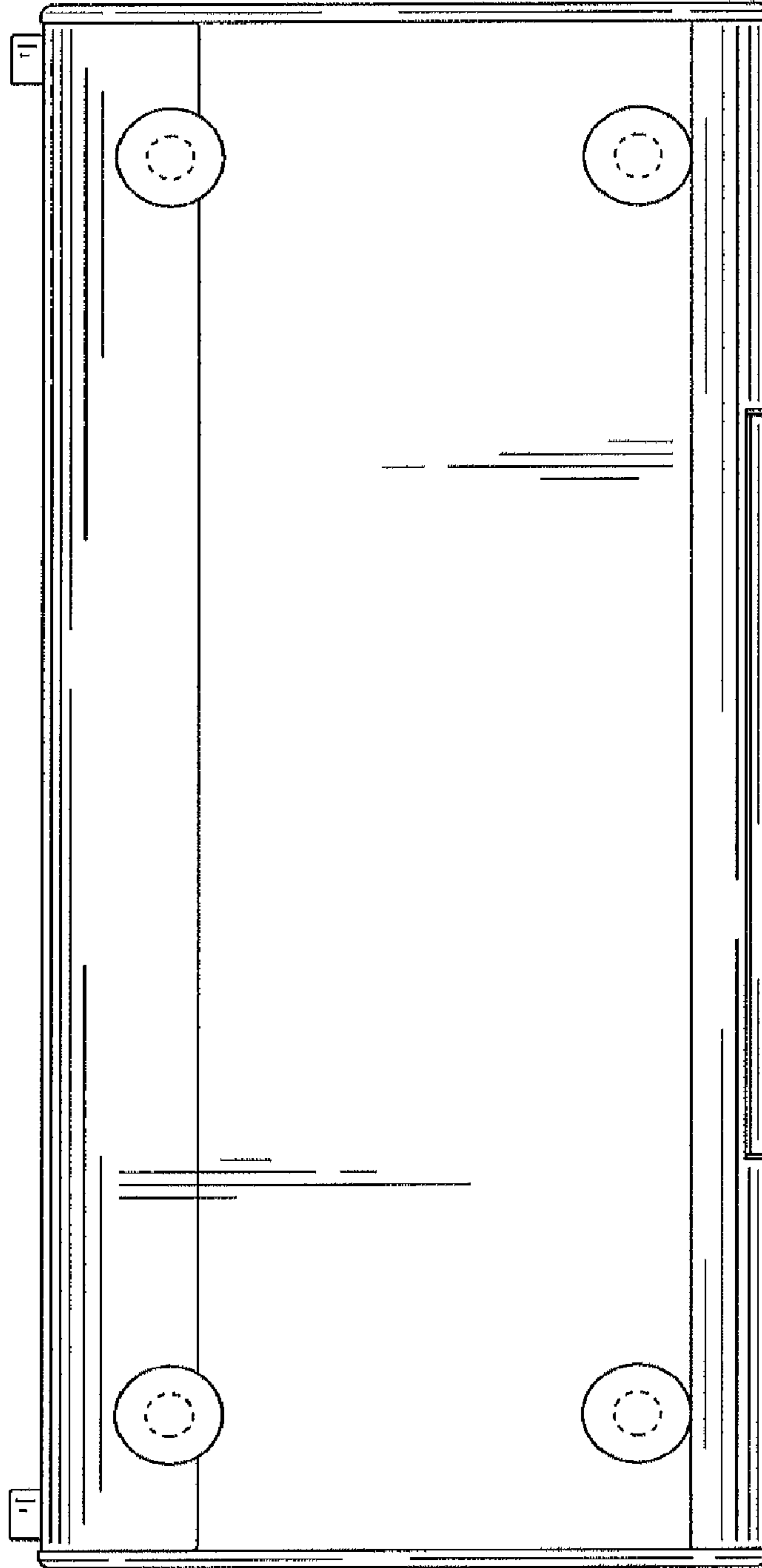

FIG. 14