



US00D674599S

(12) **United States Design Patent**
Guyon et al.

(10) **Patent No.:** **US D674,599 S**

(45) **Date of Patent:** **** Jan. 22, 2013**

(54) **HANDBAG**

(75) Inventors: **Isabelle Guyon**, Paris (FR); **Sophie Delafontaine**, Versailles (FR); **Philippe Cassegrain**, Paris (FR)

(73) Assignee: **S.A.S. Jean Cassegrain**, Paris (FR)

(**) Term: **14 Years**

(21) Appl. No.: **29/406,266**

(22) Filed: **Nov. 11, 2011**

(30) **Foreign Application Priority Data**

Aug. 6, 2011 (EM) 001874983

(51) **LOC (9) Cl.** **03-01**

(52) **U.S. Cl.** **D3/232**

(58) **Field of Classification Search** D3/232-233,
D3/240-246; 150/100, 103-110, 113-114,
150/117-119

See application file for complete search history.

(56) **References Cited**

U.S. PATENT DOCUMENTS

D110,618 S *	7/1938	Lewis	D3/240
D426,060 S *	6/2000	Chapelier	D3/303
D489,891 S	5/2004	Guyon		
D511,891 S *	11/2005	Suppangig	D3/246
D530,083 S	10/2006	Guyon		
D530,509 S	10/2006	Delafontaine		
D530,510 S *	10/2006	Suppangig	D3/246
D539,032 S	3/2007	Guyon		
D587,450 S *	3/2009	Ralston	D3/232

D606,744 S *	12/2009	Vidal	D3/232
D618,458 S	6/2010	Guyon et al.		
D620,251 S	7/2010	Guyon et al.		
D627,156 S *	11/2010	Dreyfuss	D3/243
D628,380 S	12/2010	Guyon et al.		
D634,118 S	3/2011	Guyon et al.		
D643,211 S *	8/2011	Yuson	D3/232

OTHER PUBLICATIONS

“Collection Automne”, Longchamp, Paris, 2011.
“Collection Printemps”, Longchamp, Paris, 2012.

* cited by examiner

Primary Examiner — Holly Baynham

(74) *Attorney, Agent, or Firm* — Gottlieb, Rackman & Reisman, P.C.

(57) **CLAIM**

The ornamental design for a handbag, as shown and described.

DESCRIPTION

FIG. 1 is a front elevational view of the handbag showing our new design;

FIG. 2 is a top plan view thereof, the handles of the bag being diverted from each other;

FIG. 3 is a right side elevational view thereof, the left side elevational view being a mirror image thereof;

FIG. 4 is a rear elevational view thereof; and,

FIG. 5 is a bottom plan view thereof, the handles of the bag being diverted from each other.

The broken lines in FIGS. 1-5 show the stitching and are part of the claimed design.

1 Claim, 4 Drawing Sheets

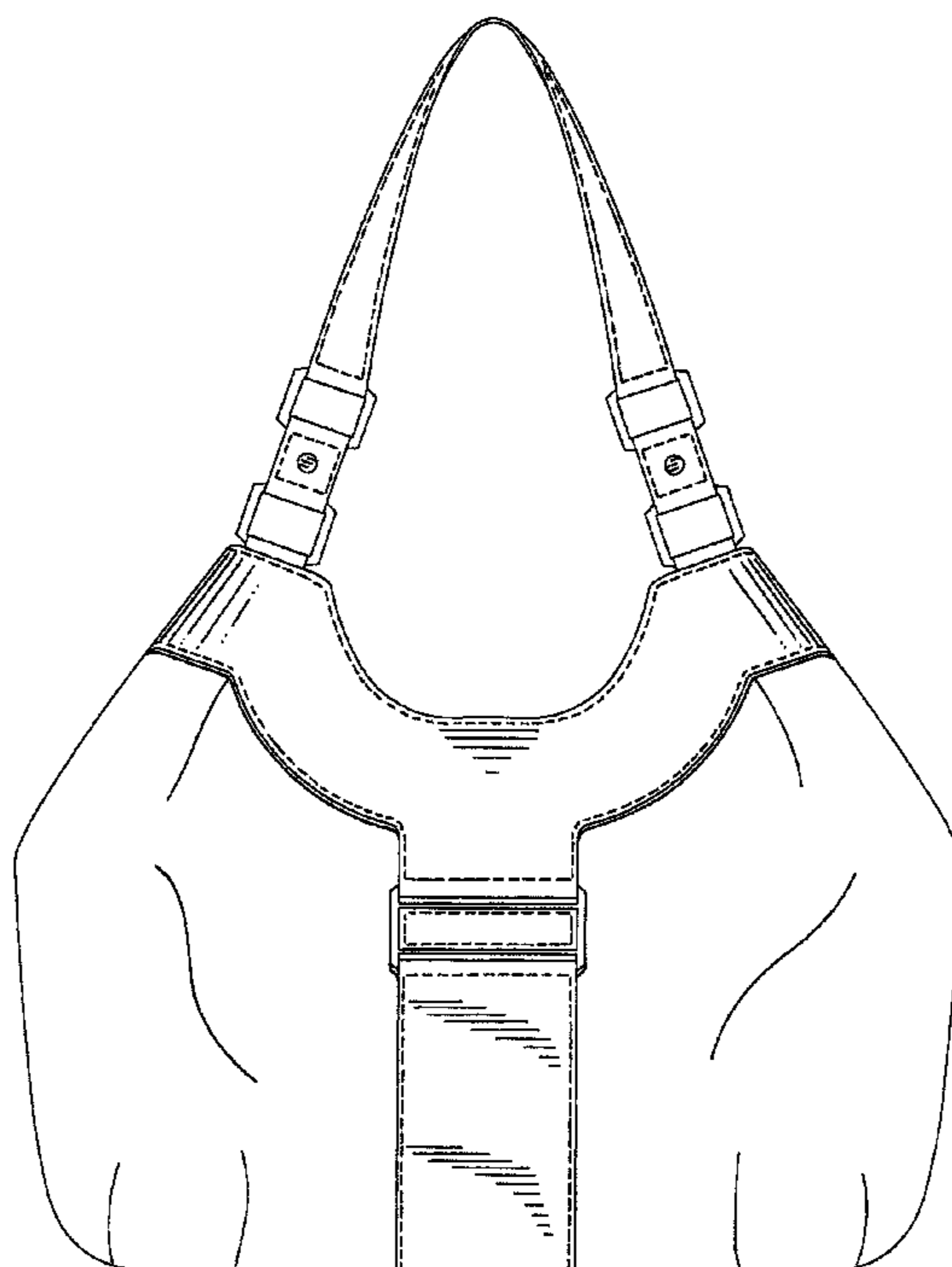
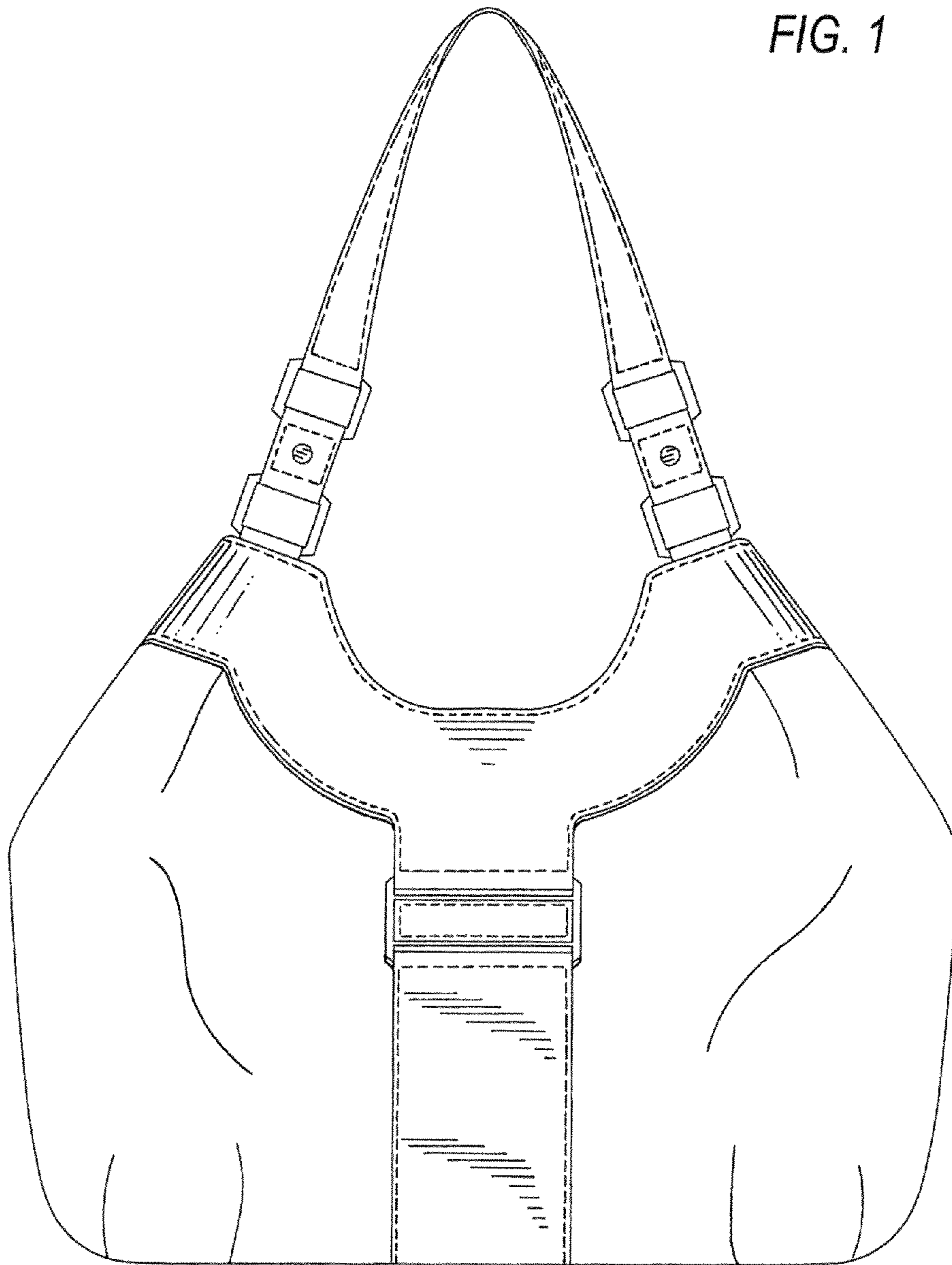

FIG. 1



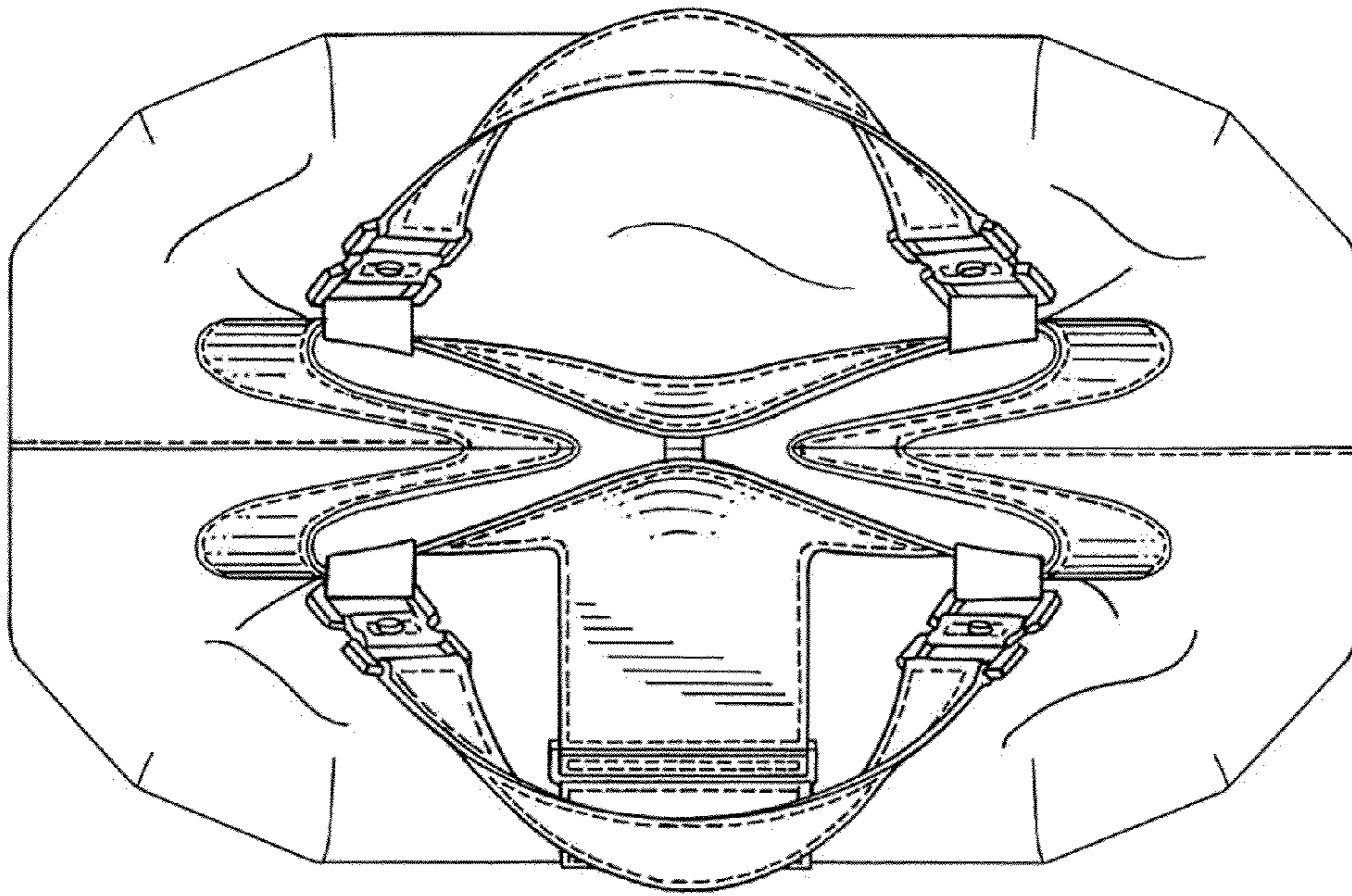

FIG. 2

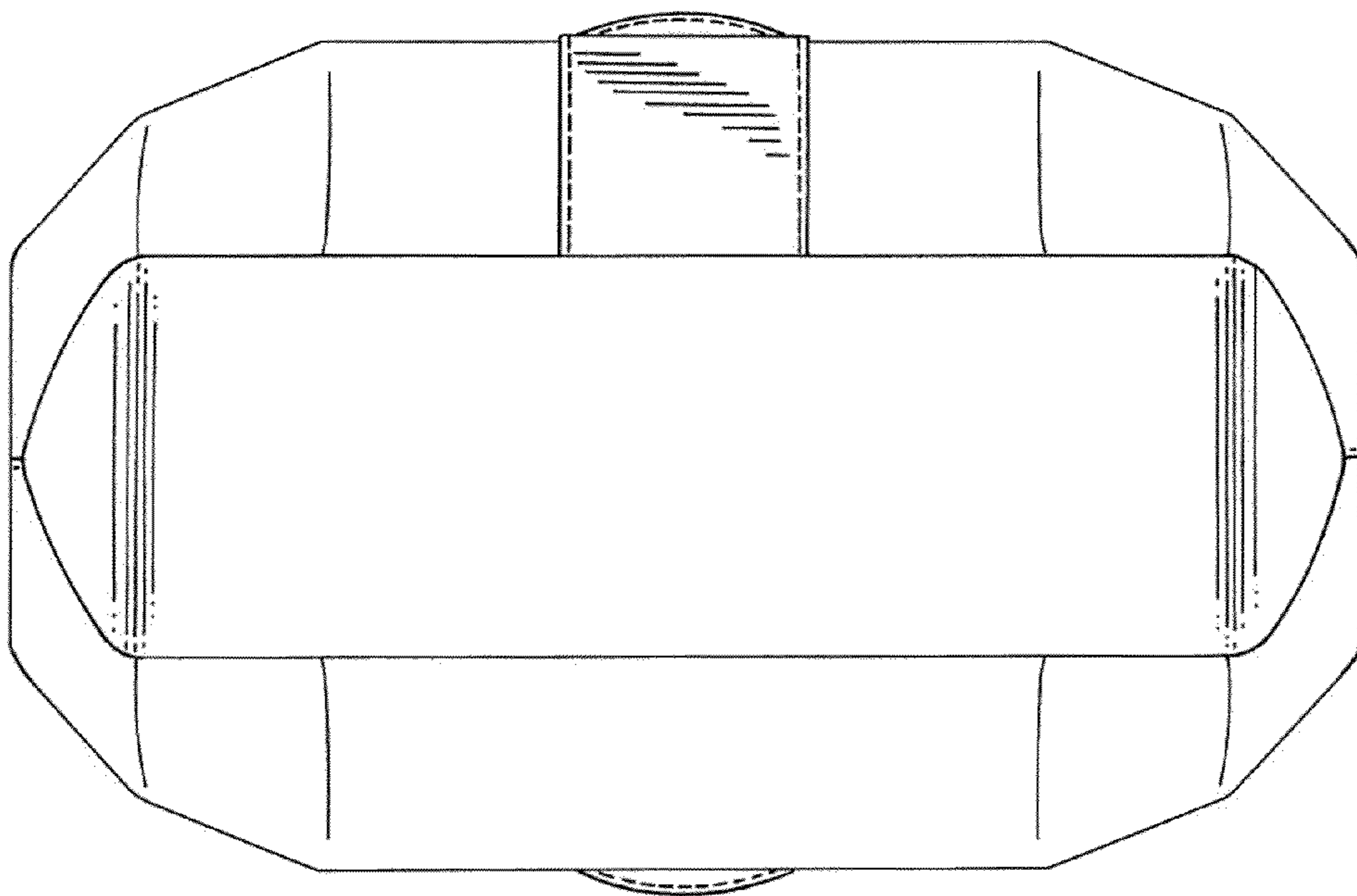

FIG. 5

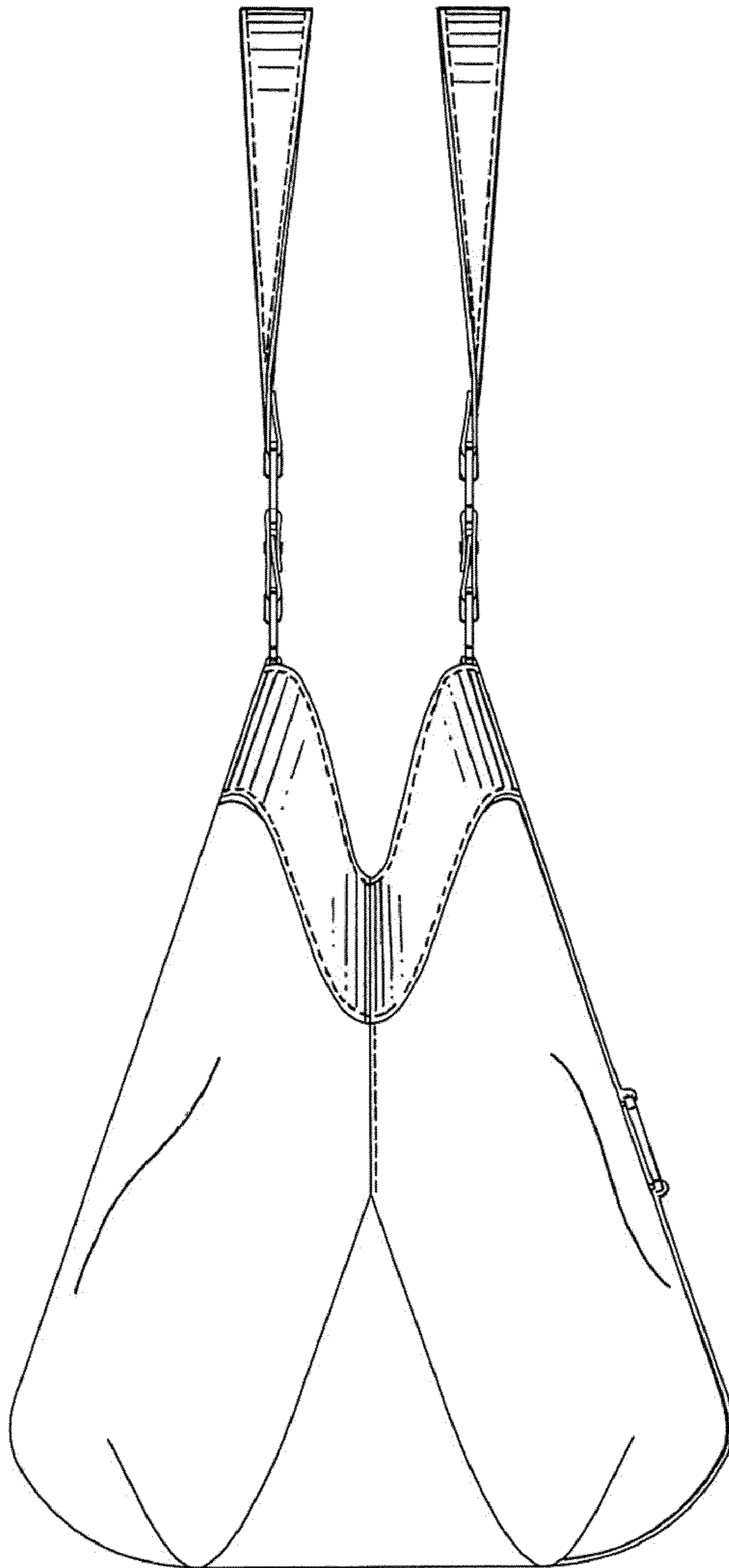

FIG. 3



FIG. 4