



US00D674192S

(12) **United States Design Patent**  
**Li**

(10) **Patent No.:** **US D674,192 S**  
(45) **Date of Patent:** **\*\* Jan. 15, 2013**

(54) **PULL ROD OF A LUGGAGE**

(75) Inventor: **Shun Yu Li**, Shanghai (CN)

(73) Assignee: **Shanghai Shentai Plastics Co., Ltd.**,  
Shanghai (CN)

(\*\*) Term: **14 Years**

(21) Appl. No.: **29/375,783**

(22) Filed: **Sep. 27, 2010**

(30) **Foreign Application Priority Data**

Jun. 11, 2010 (CN) ..... 2010 3 0203807

(51) **LOC (9) Cl.** ..... **03-01**

(52) **U.S. Cl.** ..... **D3/318**

(58) **Field of Classification Search** ..... D3/204,  
D3/318, 226, 230, 232, 243, 245, 246, 247,  
D3/249, 272, 273, 275, 276, 279, 283-285,  
D3/289, 290, 299, 303, 315, 294-296, 903;  
206/6.1, 235, 457, 349, 373, 5, 38, 380, 579,  
206/581; D8/350

See application file for complete search history.

(56) **References Cited**

**U.S. PATENT DOCUMENTS**

D370,997 S *	6/1996	Hsieh	.....	D3/318
D393,746 S *	4/1998	Wang	.....	D3/318
D440,046 S *	4/2001	Kuo	.....	D3/318
D447,929 S *	9/2001	Chang	.....	D8/350
D472,713 S *	4/2003	Lee	.....	D3/318
D491,367 S *	6/2004	Moon	.....	D3/318
D506,313 S *	6/2005	Neumann	.....	D3/318
D570,601 S *	6/2008	Drew et al.	.....	D3/318
D591,511 S *	5/2009	Wu	.....	D3/318
D607,644 S *	1/2010	Wu	.....	D3/318
D633,300 S *	3/2011	Fair	.....	D3/318

D634,545 S *	3/2011	Fair	.....	D3/318
D637,398 S *	5/2011	Jiang	.....	D3/318
D644,435 S *	9/2011	Weng	.....	D3/279
D648,132 S *	11/2011	Wu	.....	D3/318

\* cited by examiner

*Primary Examiner* — Ian Simmons

*Assistant Examiner* — Charles Hanson

(74) *Attorney, Agent, or Firm* — McCracken & Frank LLC

(57) **CLAIM**

The ornamental design for a pull rod of a luggage, as shown and described herein.

**DESCRIPTION**

FIG. 1 is the front view of the design.  
 FIG. 2 is the back view of the design.  
 FIG. 3 is the left view of the design.  
 FIG. 4 is the right view of the design.  
 FIG. 5 is the top view of the design.  
 FIG. 6 is the bottom view of the design.  
 FIG. 7 is the front view of the design when the pull rod is pulled out.  
 FIG. 8 is the back view of the design when the pull rod is pulled out.  
 FIG. 9 is the left view of the design when the pull rod is pulled out.  
 FIG. 10 is the right view of the design when the pull rod is pulled out.  
 FIG. 11 is the front view of the design when the pull rod is pulled out further; and,  
 FIG. 12 is the back view of the design when the pull rod is pulled out further.  
 The broken lines in FIGS. 11 and 12 are included to indicate a break along the length of the lower section of the pull rod because it is longer than the space available. These broken lines form no part of the claimed design.

**1 Claim, 5 Drawing Sheets**

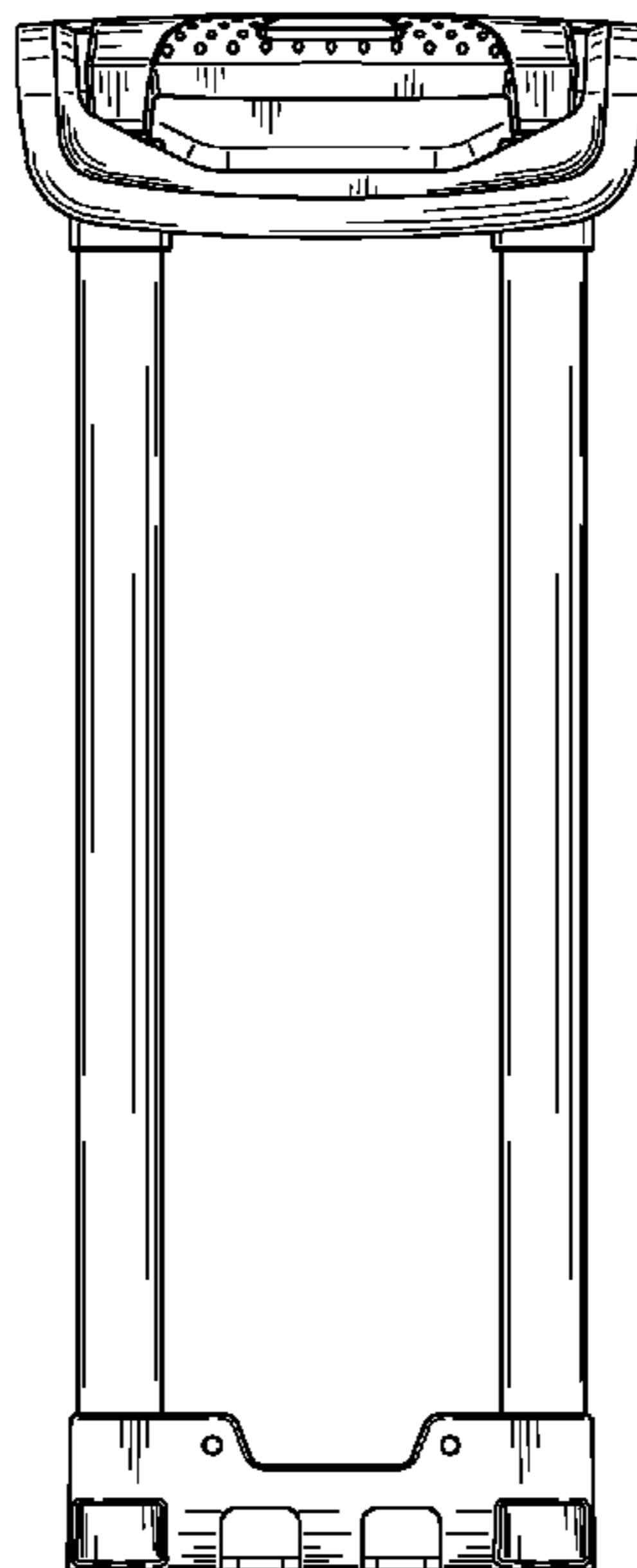

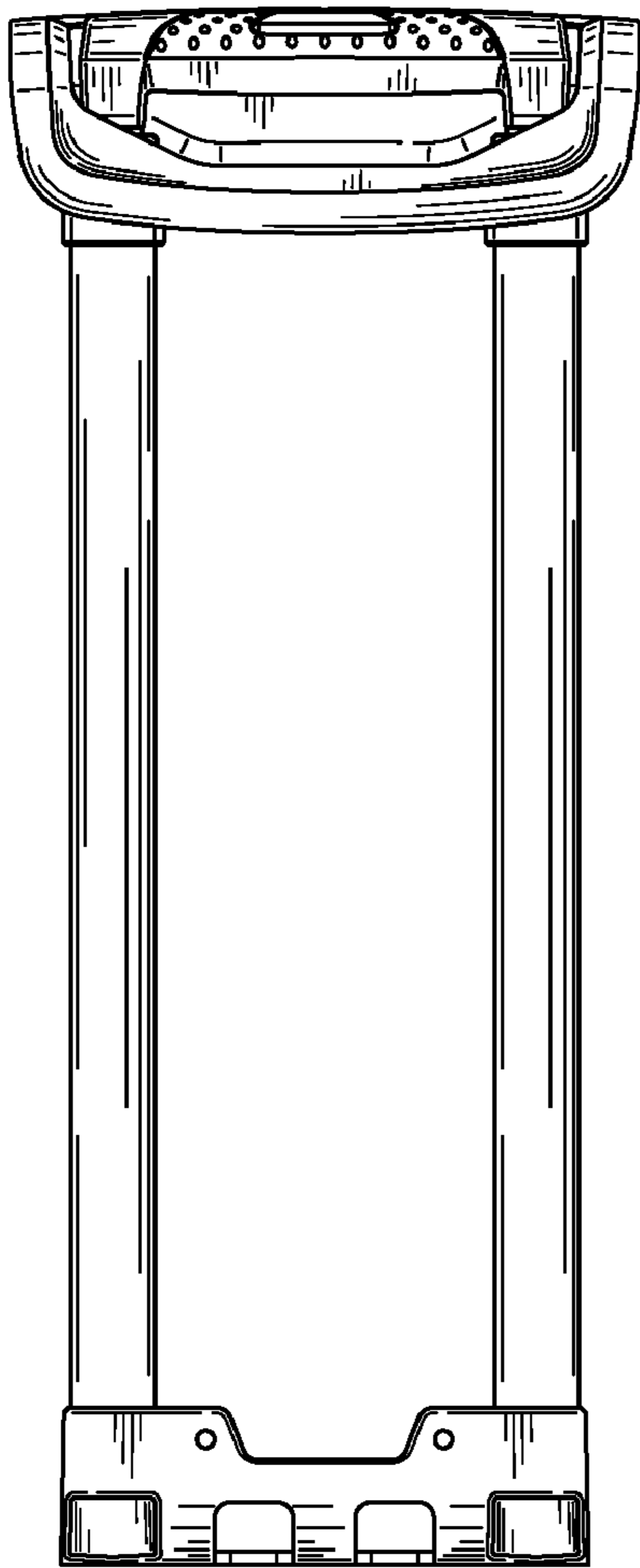

FIG. 1

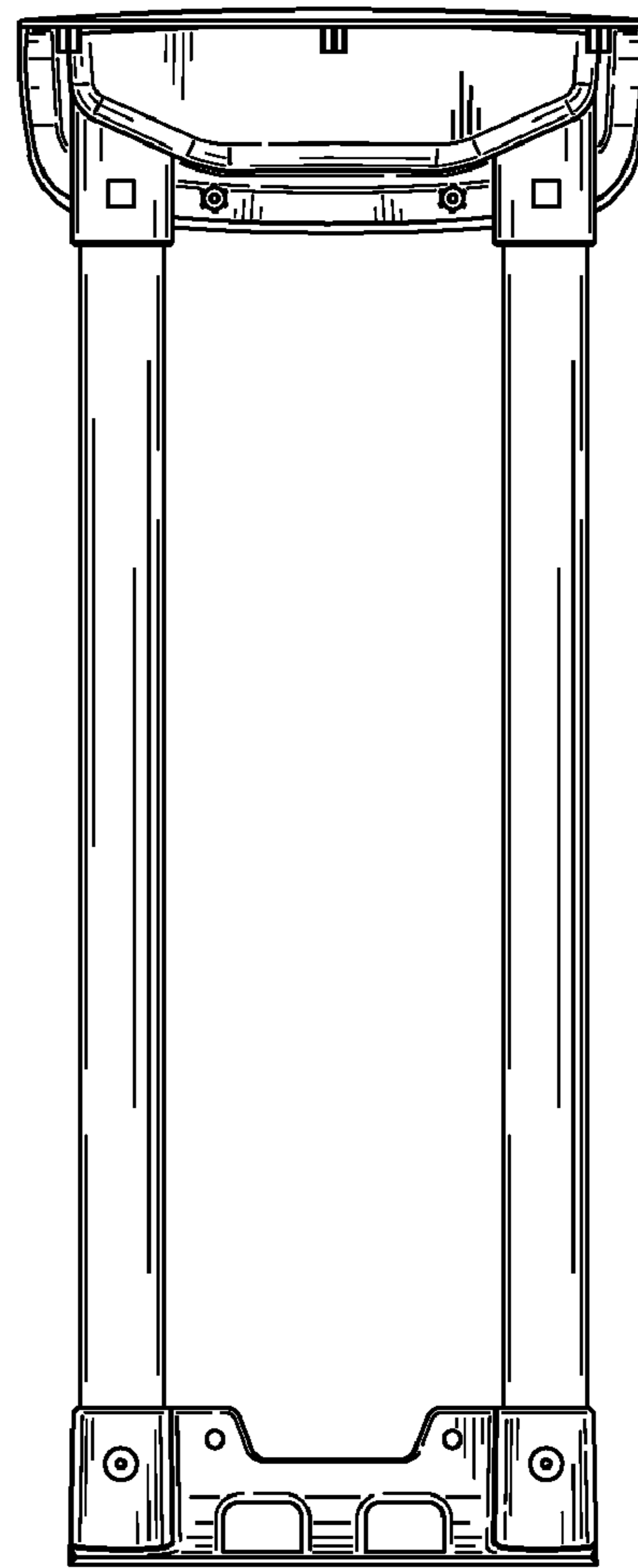

FIG. 2

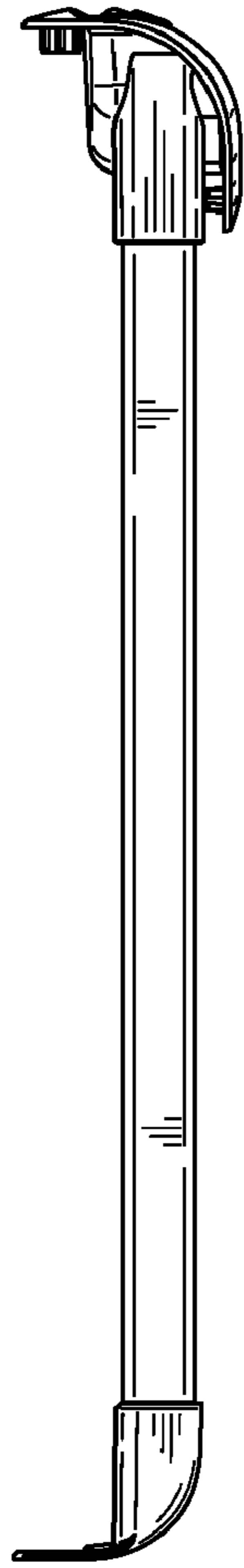

FIG. 3

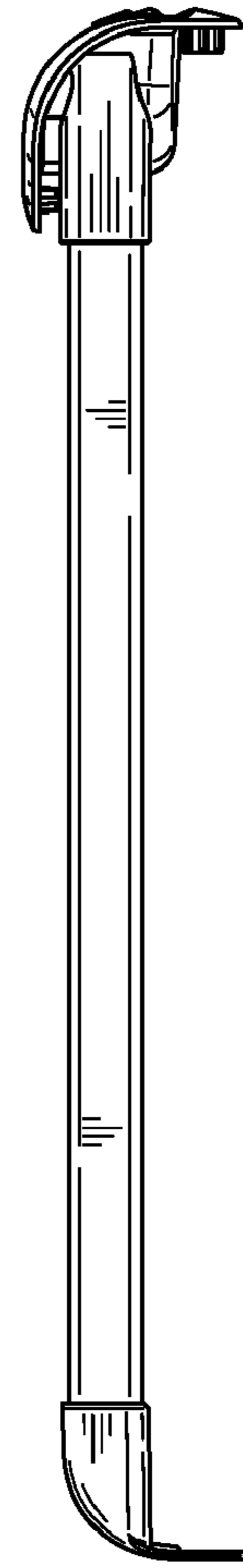

FIG. 4

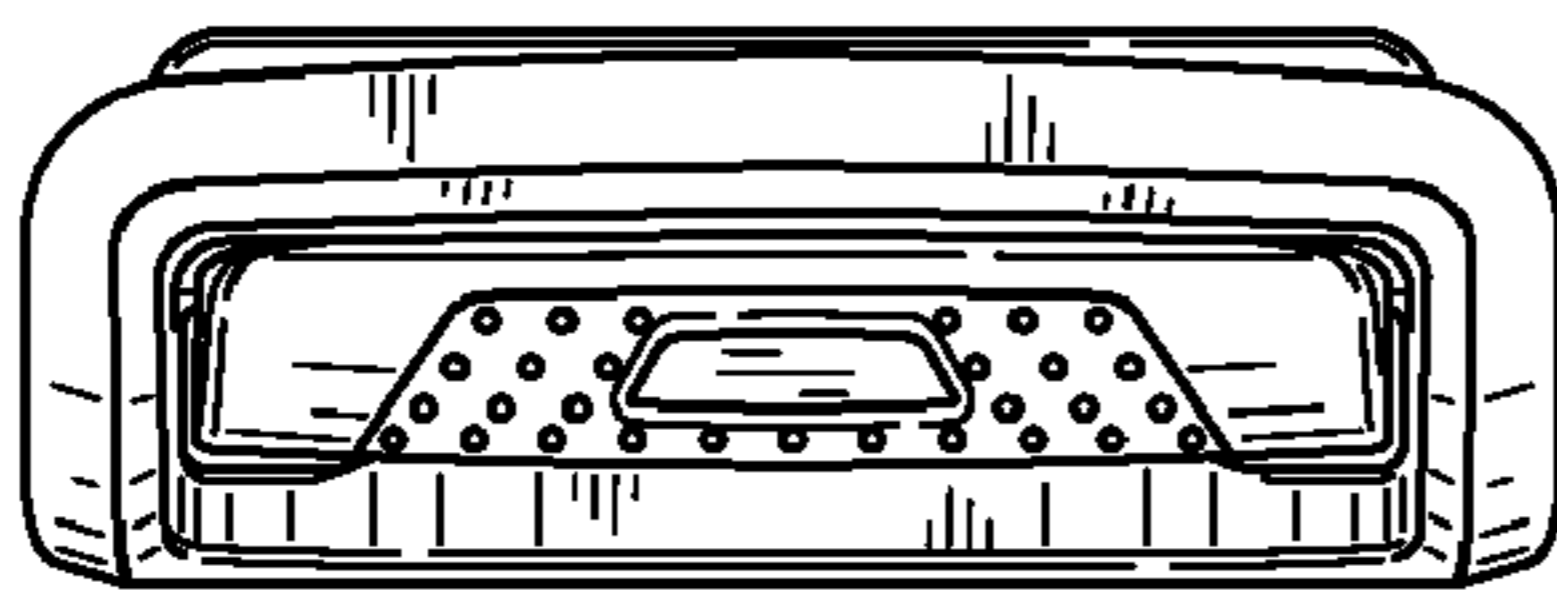

FIG. 5

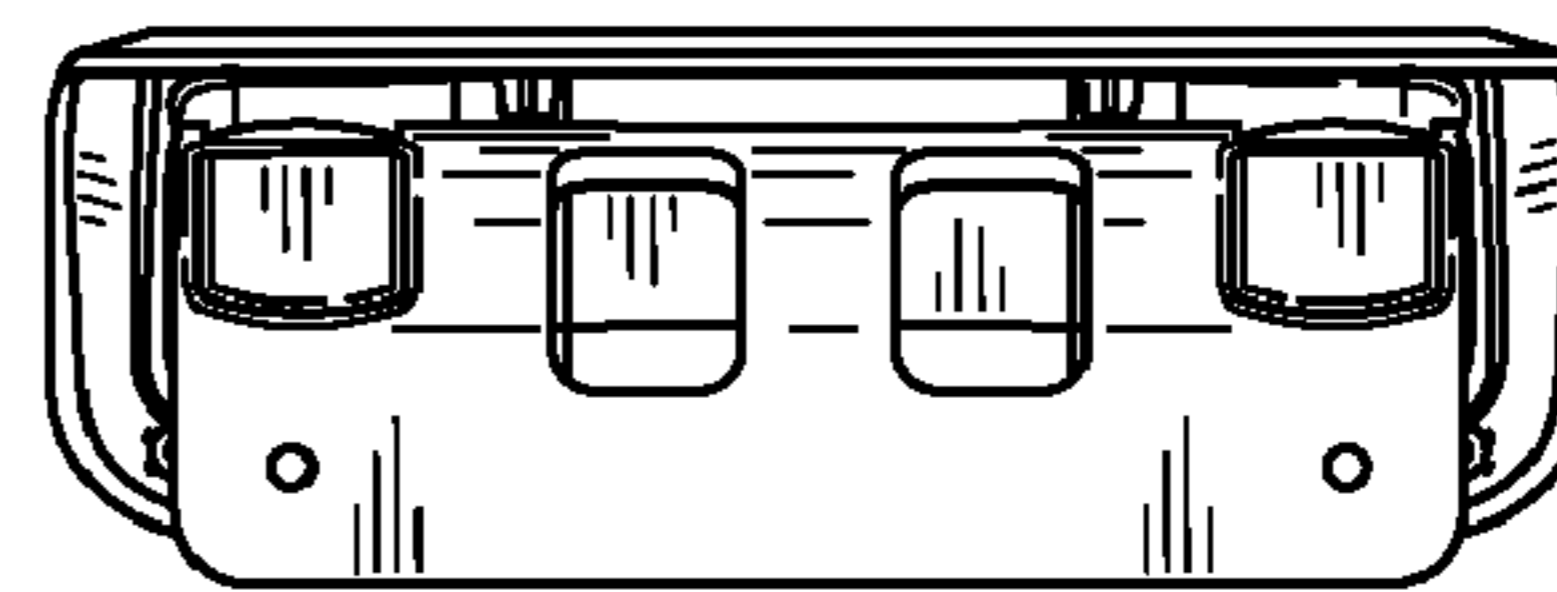

FIG. 6

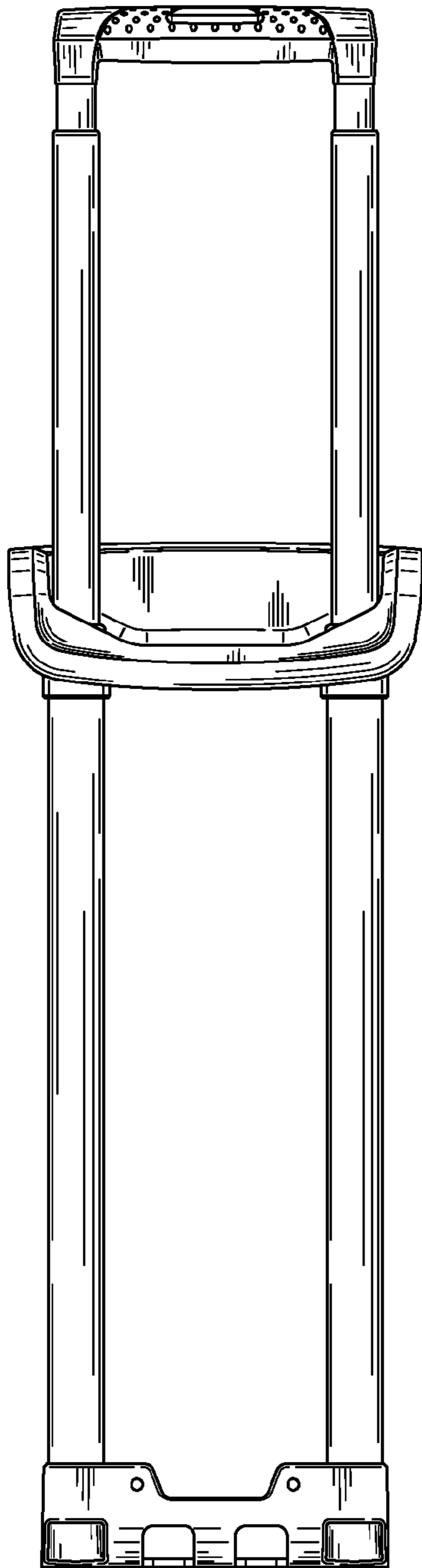

FIG. 7

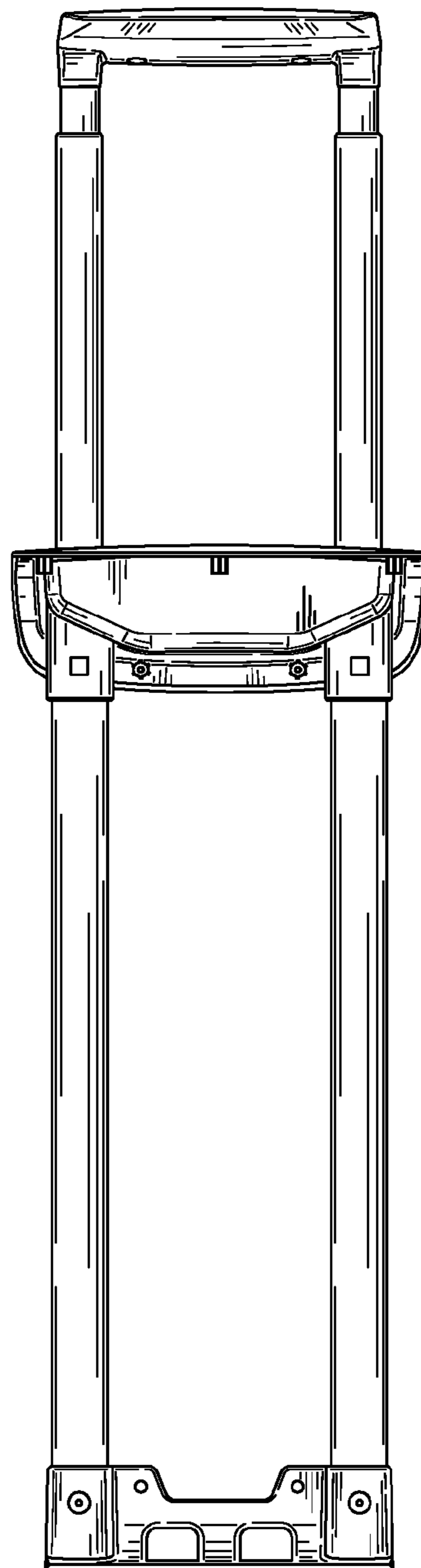

FIG. 8

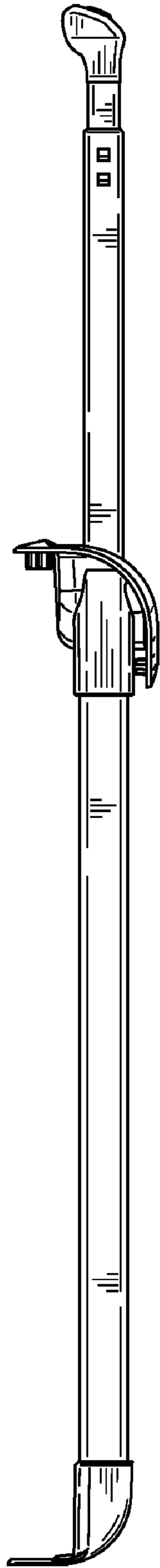

FIG. 9

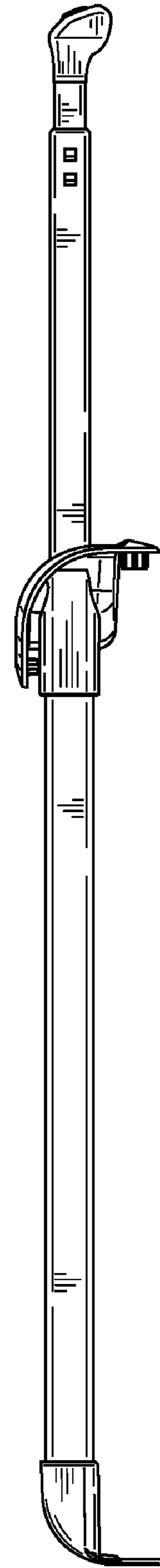

FIG. 10

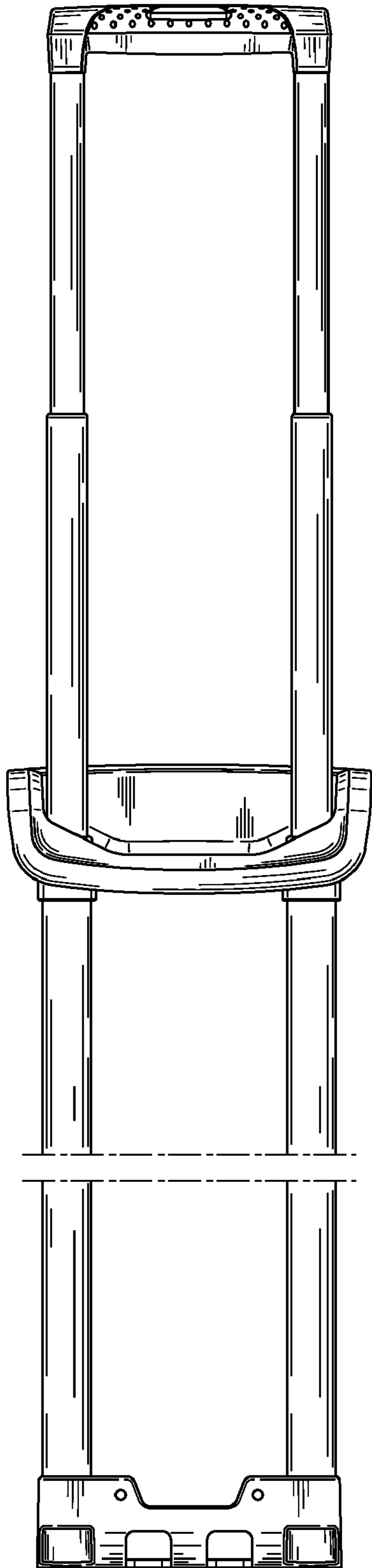

FIG. 11

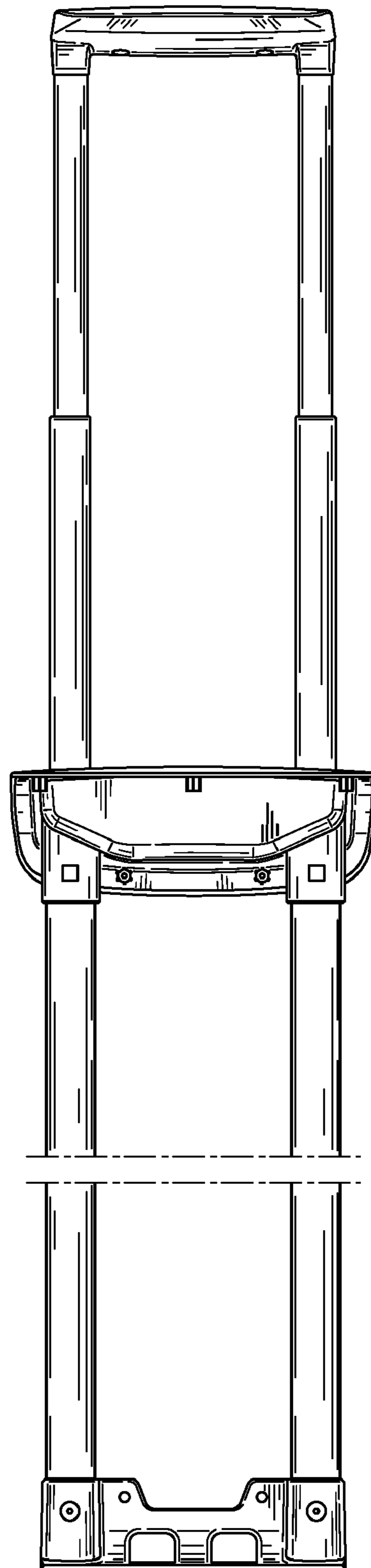

FIG. 12