



US00D673981S

(12) **United States Design Patent**
Kopacz et al.

(10) **Patent No.:** **US D673,981 S**
(45) **Date of Patent:** **** Jan. 8, 2013**

(54) **ASPHALT SCREED**

(75) Inventors: **Jason W. Kopacz**, St. Louis Park, MN (US); **Joseph P. Spree**, Champlin, MN (US); **Tobin D. Rasmusson**, Bloomington, MN (US); **Tony P. Steinhagen**, Maple Grove, MN (US); **Joe A. Frerich**, Champlin, MN (US); **Brett W. Engel**, Brooklyn Park, MN (US); **Douglas W. Halverson**, Isanti, MN (US)

(73) Assignee: **Caterpillar Paving Products Inc.**, Minneapolis, MN (US)

(**) Term: **14 Years**

(21) Appl. No.: **29/403,108**

(22) Filed: **Sep. 30, 2011**

(51) **LOC (9) Cl.** **15-03**

(52) **U.S. Cl.** **D15/19; D15/22**

(58) **Field of Classification Search** D15/10, D15/13, 19, 22-26, 28; 404/110, 101, 108, 404/75, 102, 118, 84.08, 105

See application file for complete search history.

(56) **References Cited**

U.S. PATENT DOCUMENTS

D135,005 S * 2/1943 Baumgardner D15/10
(Continued)

FOREIGN PATENT DOCUMENTS

EP 1577443 9/2005

OTHER PUBLICATIONS

“AB 340 Extending Screed”, document downloaded from the Voegele Website at <http://www.voegele.info/en/produkte/einbaubohlen/ausziehbohlen/ab_340/AB_340_-_Einzelseite.php>.

(Continued)

Primary Examiner — Mark Goodwin

(74) Attorney, Agent, or Firm — Carl E. Myers

(57) **CLAIM**

The ornamental design for an asphalt screed, as shown and described.

DESCRIPTION

FIG. 1 is a front view of an asphalt screed showing our new design in an extended configuration.

FIG. 2 is a right front perspective view of an asphalt screed showing our new design in an extended configuration.

FIG. 3 is a right side view of an asphalt screed showing our new design in an extended configuration.

FIG. 4 is a right rear perspective view of an asphalt screed showing our new design in an extended configuration.

FIG. 5 is a rear view of an asphalt screed showing our new design in an extended configuration.

FIG. 6 is a right rear perspective view of an asphalt screed showing our new design in an extended configuration.

FIG. 7 is a left side view of an asphalt screed showing our new design in an extended configuration.

FIG. 8 is a left front perspective view of an asphalt screed showing our new design in an extended configuration.

FIG. 9 is a plan view of an asphalt screed showing our new design in an extended configuration.

FIG. 10 is a front view of an asphalt screed showing our new design in a retracted configuration.

FIG. 11 is a right front perspective view of an asphalt screed showing our new design in a retracted configuration.

FIG. 12 is a right side view of an asphalt screed showing our new design in a retracted configuration.

FIG. 13 is a right rear perspective view of an asphalt screed showing our new design in a retracted configuration.

FIG. 14 is a rear view of an asphalt screed showing our new design in a retracted configuration.

FIG. 15 is a right rear perspective view of an asphalt screed showing our new design in a retracted configuration.

FIG. 16 is a left side view of an asphalt screed showing our new design in a retracted configuration.

FIG. 17 is a left front perspective view of an asphalt screed showing our new design in a retracted configuration; and,

FIG. 18 is a plan view of an asphalt screed showing our new design in a retracted configuration.

The broken line showing of an asphalt paver is included for the purpose of illustrating environmental structure and forms no part of the claimed design.

1 Claim, 18 Drawing Sheets

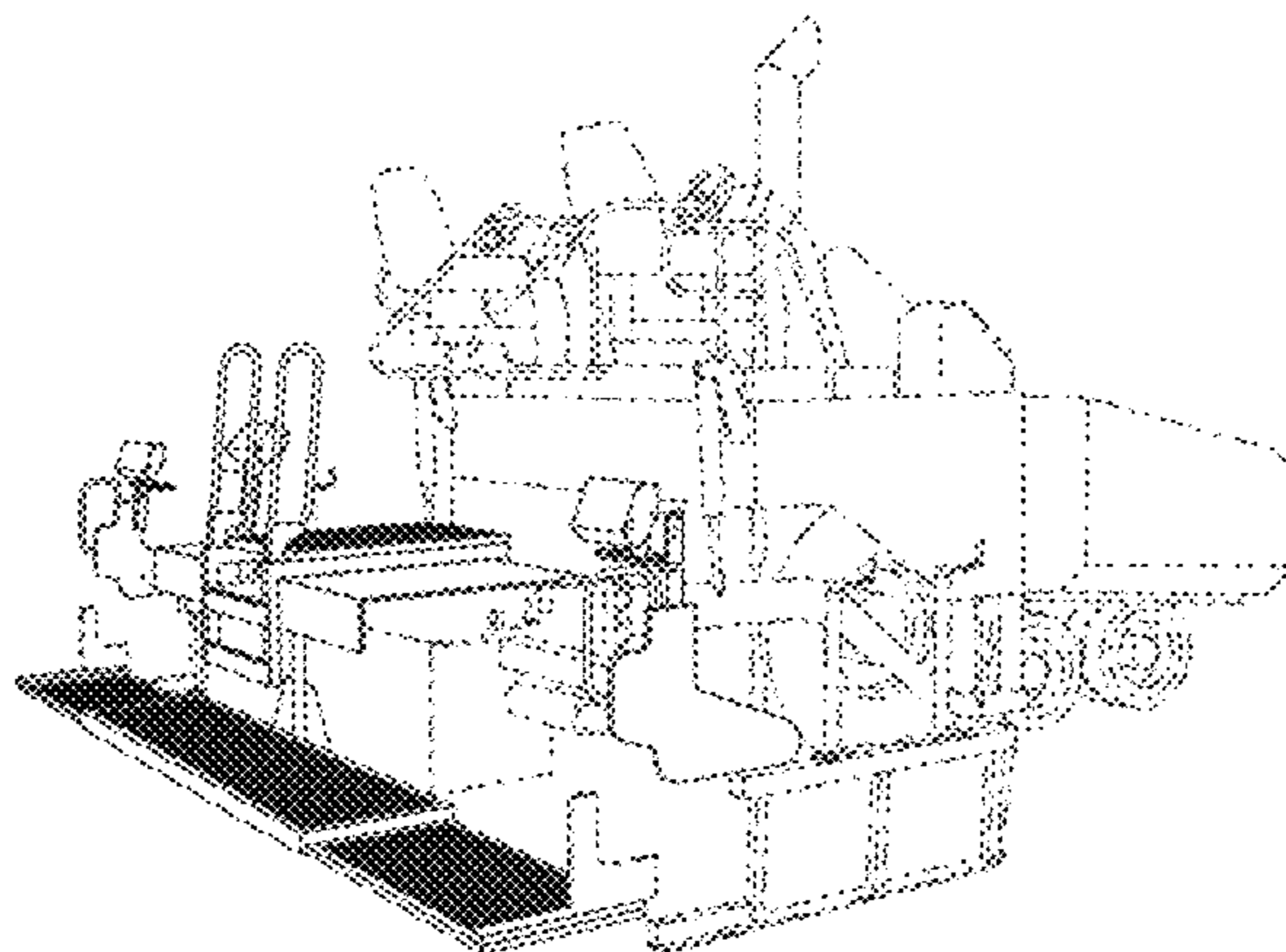

U.S. PATENT DOCUMENTS

3,000,277	A *	9/1961	Crane et al.	404/118
D206,177	S *	11/1966	Unruh	D8/10
D214,435	S *	6/1969	Naeve	D12/218
D219,011	S *	10/1970	Marushak et al.	D12/218
D239,966	S *	5/1976	Swisher et al.	D15/22
3,997,277	A *	12/1976	Swisher et al.	404/84.05
D256,466	S *	8/1980	Smith et al.	D15/22
D266,850	S *	11/1982	Godbersen	D15/22
D323,511	S *	1/1992	Swisher, Jr.	D15/23
5,201,603	A *	4/1993	Bassett et al.	404/84.1
5,201,604	A *	4/1993	Ferguson et al.	404/110
5,203,642	A	4/1993	Heller et al.	
D362,449	S *	9/1995	Swisher, Jr.	D15/22
5,511,900	A *	4/1996	Macku	404/84.1
D370,917	S *	6/1996	Swisher, Jr.	D15/29
D397,121	S *	8/1998	Smith	D15/15
6,007,272	A *	12/1999	Macku et al.	404/92
6,099,205	A *	8/2000	Macku et al.	404/92
D433,425	S *	11/2000	Surridge et al.	D15/17
6,193,437	B1 *	2/2001	Heims	404/110
6,273,636	B1	8/2001	Johanpeter	
6,375,386	B1 *	4/2002	Macku et al.	404/17
D457,175	S *	5/2002	Goebert et al.	D15/33
D500,056	S *	12/2004	DeYoung et al.	D15/33
D526,336	S *	8/2006	Maas et al.	D15/28
D527,393	S *	8/2006	Maas et al.	D15/28
D562,350	S *	2/2008	Higashikawa	D15/17
D573,611	S *	7/2008	Geier	D15/20
D578,142	S *	10/2008	Ewringmann	D15/22
D589,067	S *	3/2009	Yamamoto	D15/28
D591,775	S *	5/2009	Kokitkar et al.	D15/28
D599,825	S *	9/2009	Schneider et al.	D15/22
D608,374	S *	1/2010	De Rycke et al.	D15/33
D618,711	S *	6/2010	Tokuhara	D15/28
D623,670	S *	9/2010	Escobar	D15/28
D632,308	S *	2/2011	Kopacz et al.	D15/19
D635,158	S *	3/2011	Berning et al.	D15/33
D635,159	S *	3/2011	Berning et al.	D15/33
D635,160	S *	3/2011	Berning et al.	D15/33
D635,593	S *	4/2011	Berning et al.	D15/33
D638,860	S *	5/2011	Kopacz et al.	D15/19
D642,599	S *	8/2011	Busley	D15/33
D643,858	S *	8/2011	Kopacz et al.	D15/19
D643,860	S *	8/2011	Busley	D15/33
D644,669	S *	9/2011	Escobar	D15/28
D650,396	S *	12/2011	Ewringmann	D15/22
D652,432	S *	1/2012	Kopacz et al.	D15/19

OTHER PUBLICATIONS

“AB500-2 and AB 600-2 Extending Screeds” document downloaded from the Vogele website at <http://www.resansil.com/english/images/vogele/ab500_2_ab600_2_en.pdf>.

“Omniscreed IA” document downloaded from the Volvo website at <http://www.volvoce.com/SiteCollectionDocuments/VCE/Documents%20Global/blaw%20knox%20screeds/22A1004066_Volvo_OmniScreed%20IA%20Product%20Brochure.pdf>.

“Wedge-Lock Screeds” document downloaded from the Volvo website at <http://www.volvoce.com/SiteCollectionDocuments/VCE/Documents%20Global/blaw%20knox%20screeds/22A1004065_Volvo_Wedge-Lock%20Screed%20Product%20Brochure.pdf>.

“Blaw-Knox Screeds” document downloaded from the Volvo website at <<http://www.volvoce.com/constructionequipment/na/en-us/products/pavers/blawknoxscreeds/pages/introduction.aspx>>.

“ABG Screed—Variomatic” document downloaded from the Volvo website at <<http://www.volvoce.com/constructionequipment/na/en-us/products/pavers/abgscreedsvariomatic/Pages/introduction.aspx>>.

“Ultimat 200” document downloaded from the Volvo website at <http://www.volvoce.com/SiteCollectionDocuments/VCE/Documents%20Global/blaw%20knox%20screeds/Ultimat200_22A1005745_Ir.pdf>.

“Eagle Series Screed” document downloaded from the Roadtec website at <http://www.roadtec.com/images/roadtec_literature/screeds/screeds.pdf>.

“EZ III” document downloaded from the Carlson website at <<http://www.carlsonpavingproducts.com/downloads/screedIII.pdf>>.

“EZ IV” document downloaded from the Carlson website at <<http://www.carlsonpavingproducts.com/downloads/screed-IV.pdf>>.

“VB340TV-E” document downloaded from the Dynapac website at <<http://www.dynapac.com/en/Products/?product=122&cat=45>>.

“Apollo Screed” document downloaded from the Apollo website at <<http://www.apollo.co.in/hydrostatic-sensor-paver-finishers-ap-550-gallery.html>>.

“Screed on AFW 500 E/G paver” document downloaded from the Ammann website at <http://www.ammann-group.it/fileadmin/ammann/pdf/fertiger/ammann-paver_AFW500_en.pdf>.

“Caterpillar Extend-A-Mat” document downloaded from the Caterpillar website at <<http://www.cat.com/cda/layout?m=607793&x=7>>.

“Caterpillar Vers-A-Mat” document downloaded from the Caterpillar website at <<http://www.cat.com/cda/layout?m=607792&x=7>>.

* cited by examiner

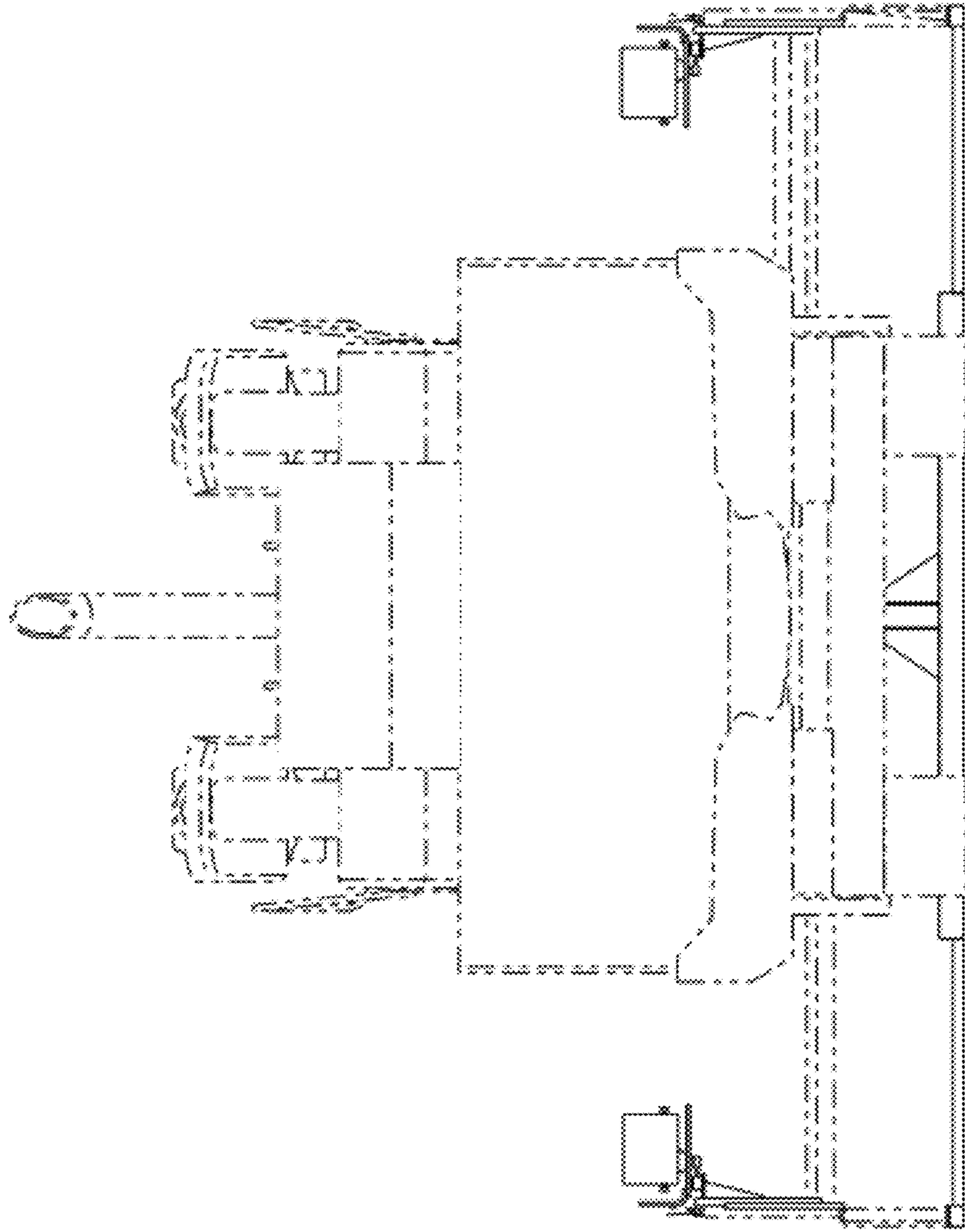

FIG. 1

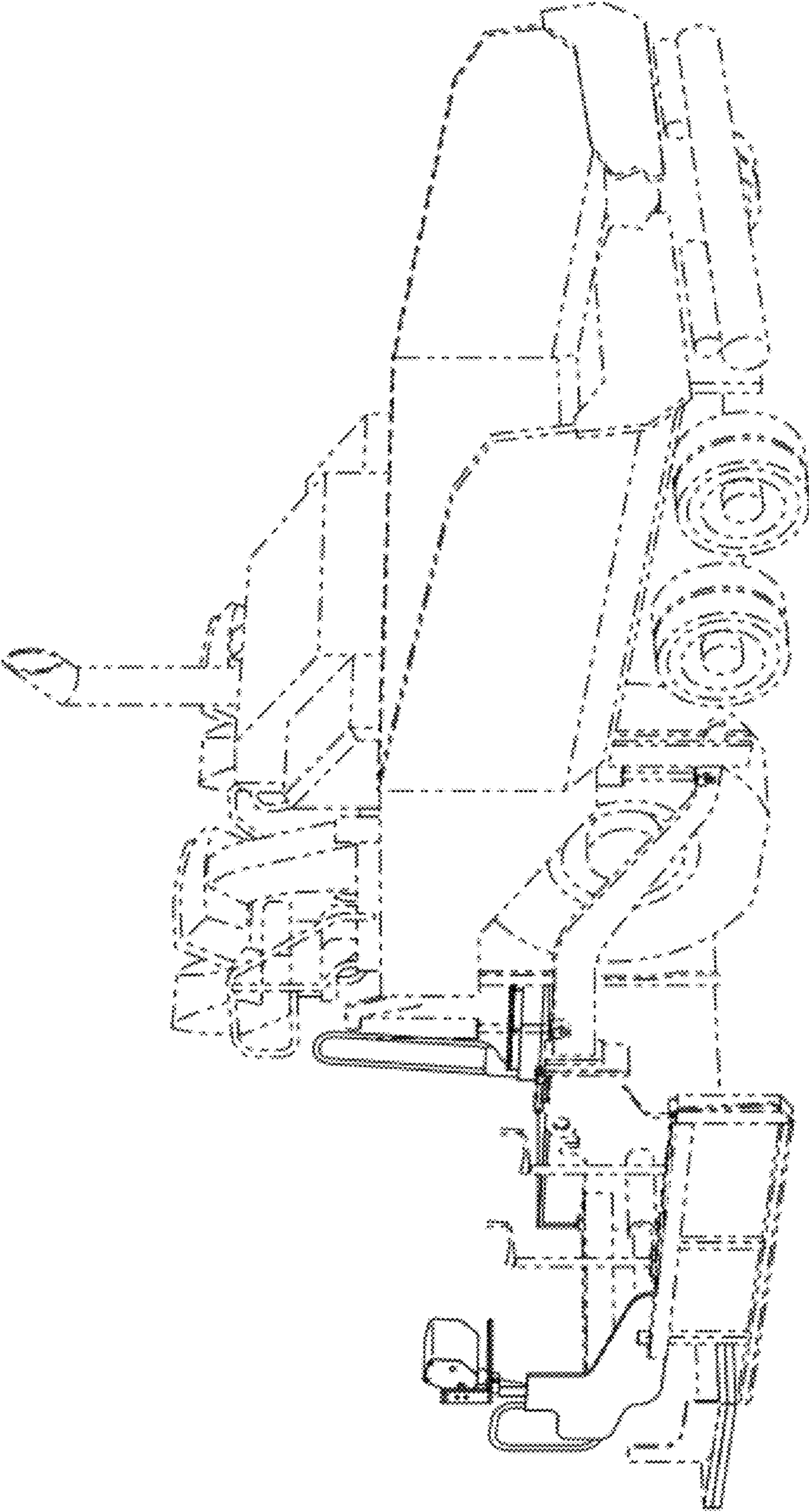

FIG. 2

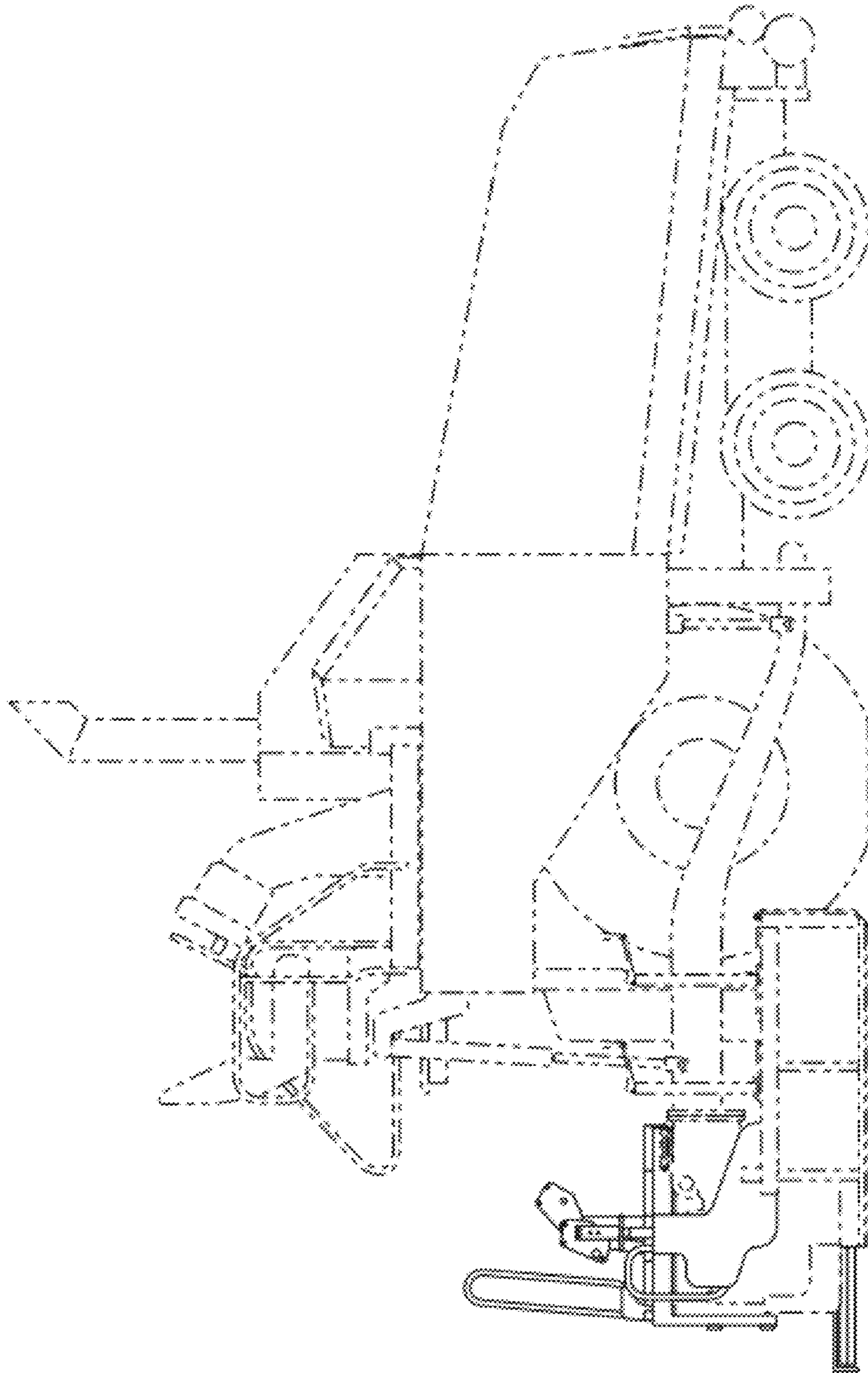

FIG. 3

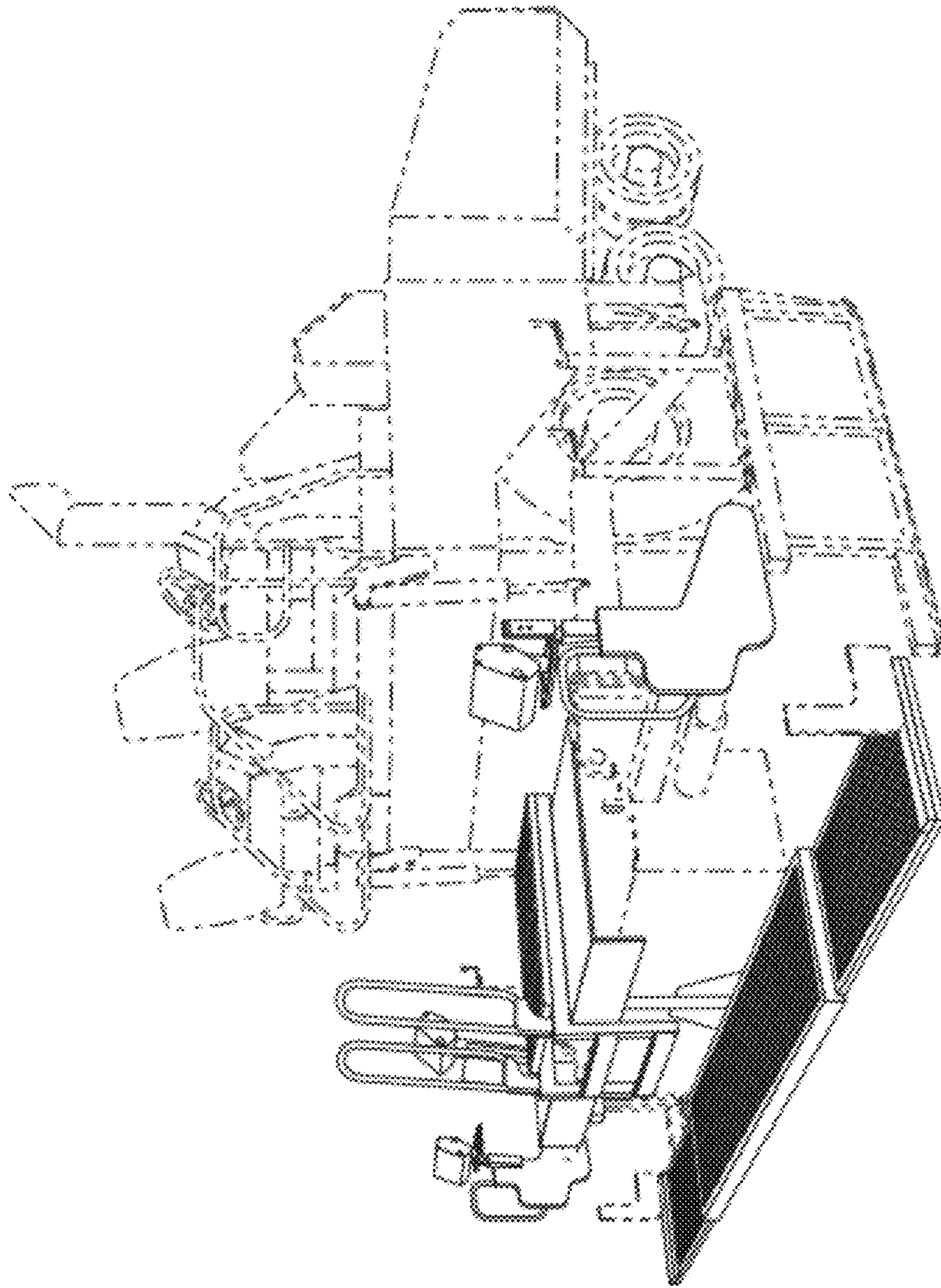

FIG. 4

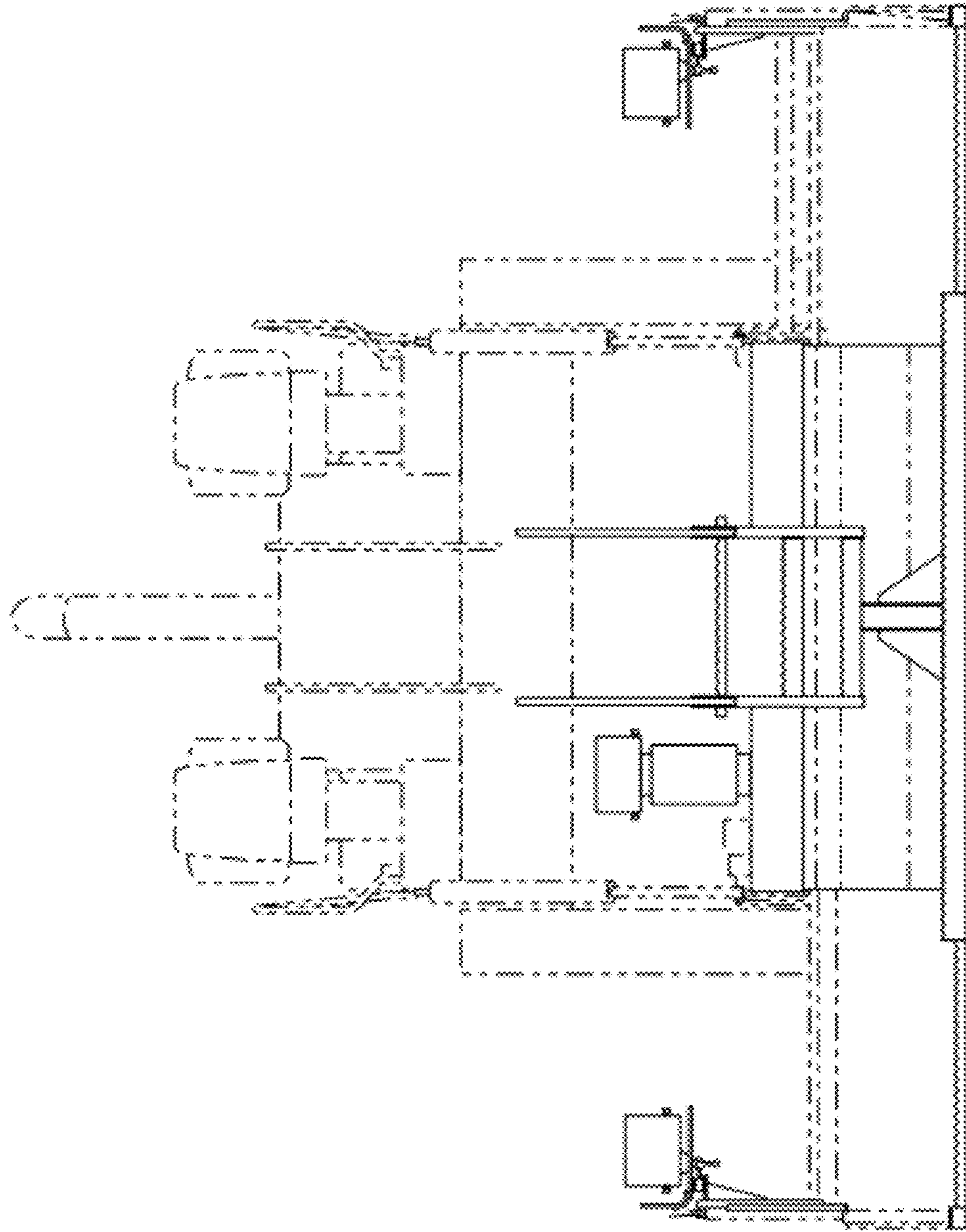

FIG. 5

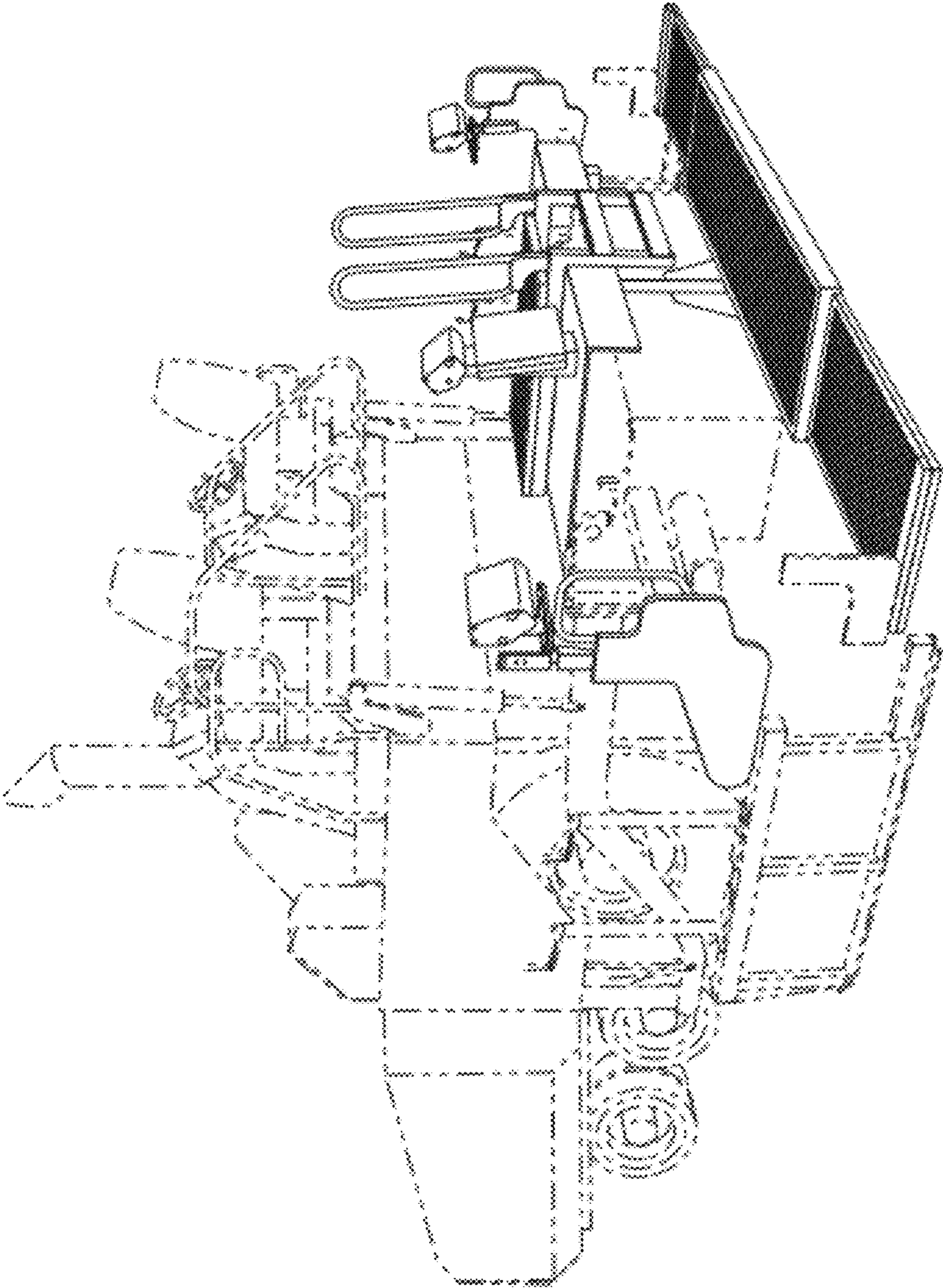

FIG. 6

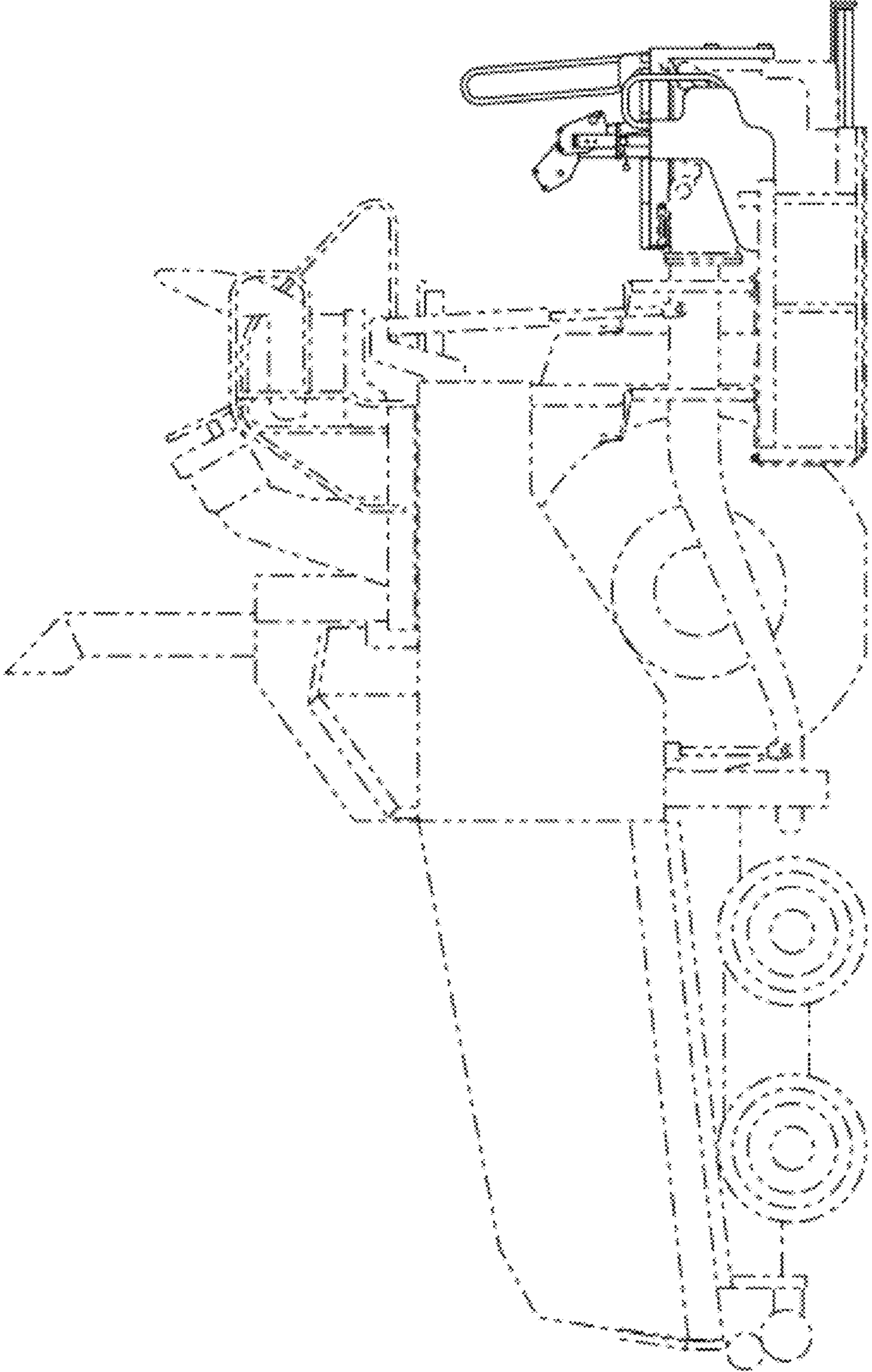

FIG. 7

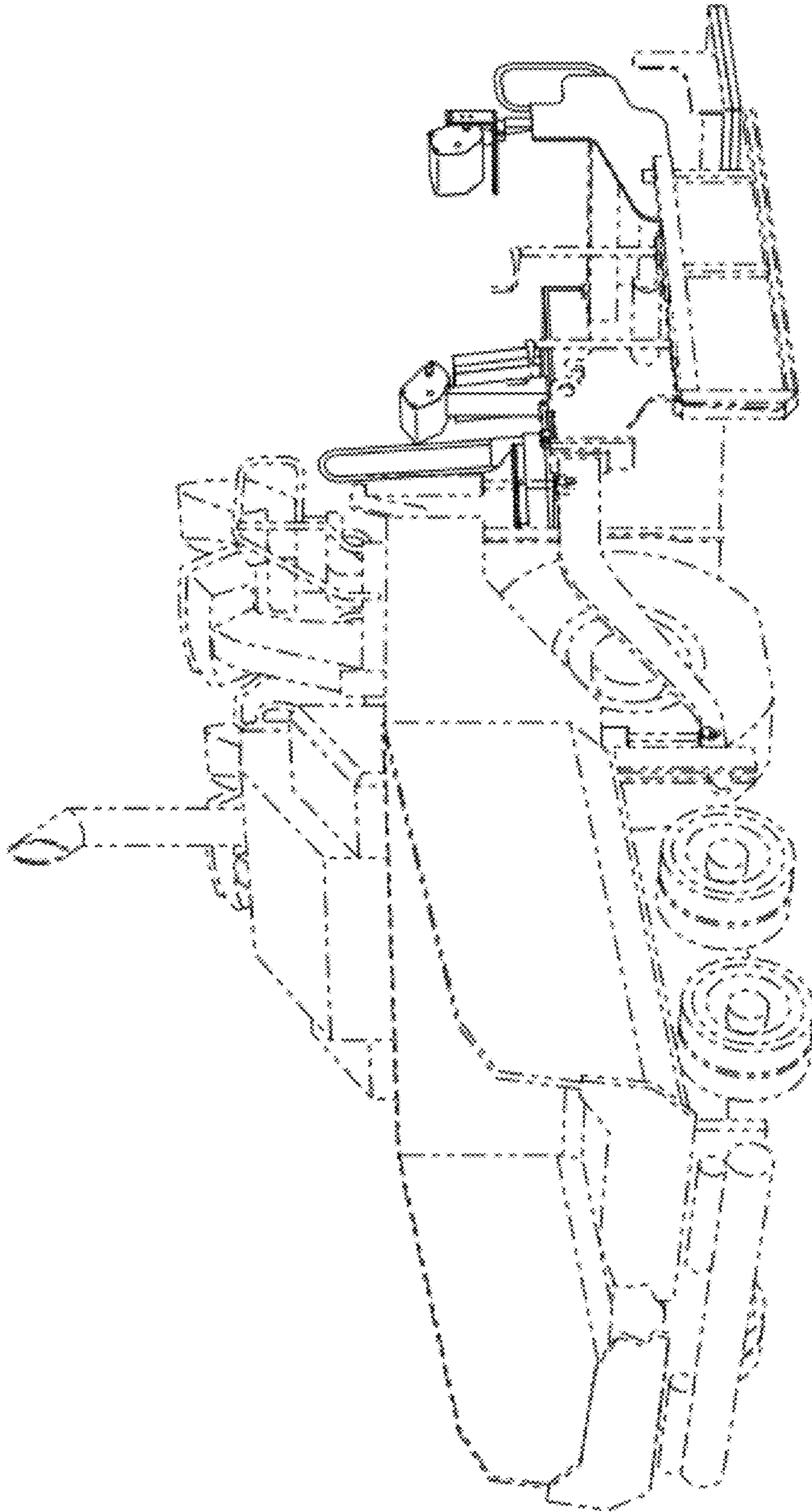

FIG. 8

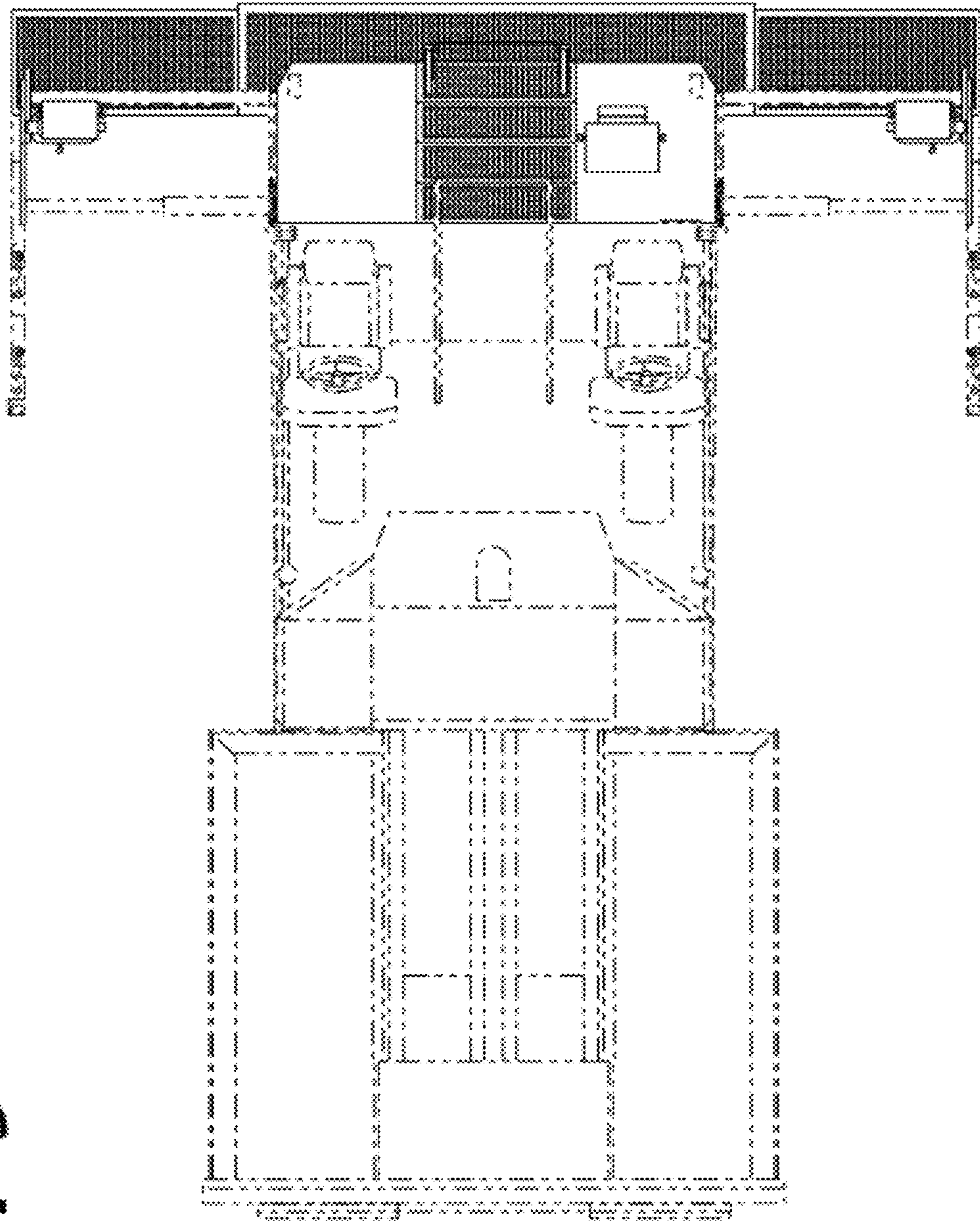

FIG. 9

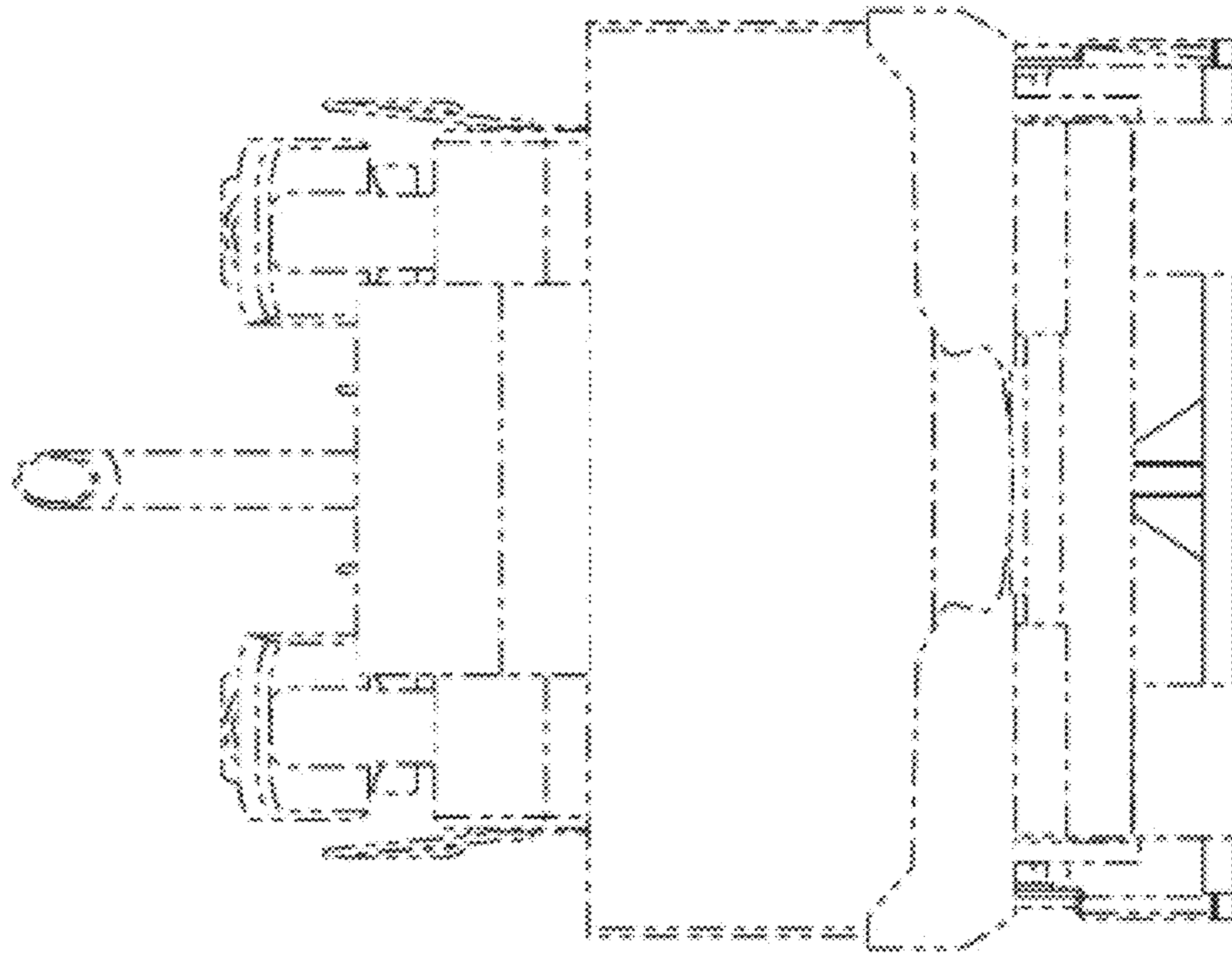

FIG. 10

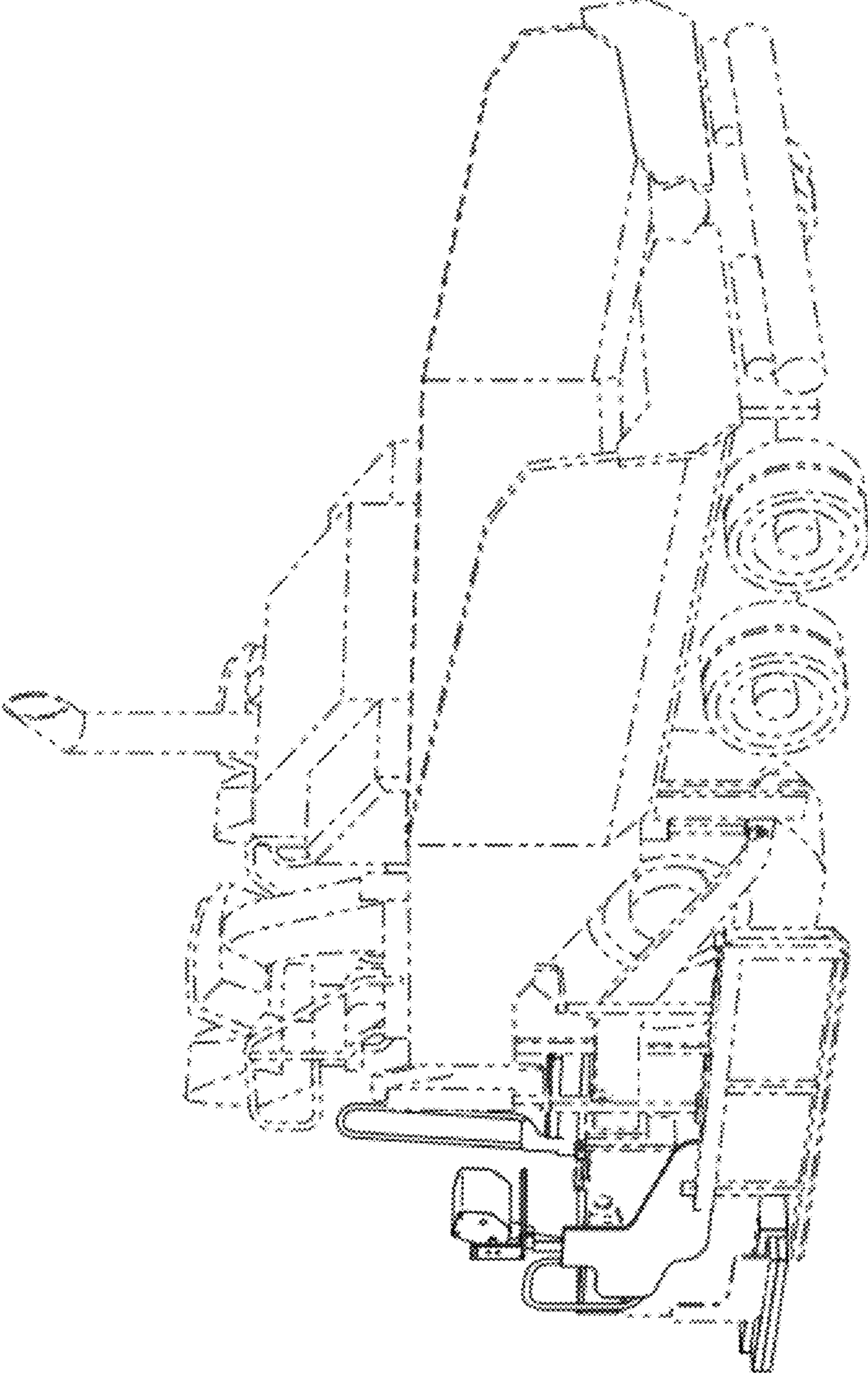

FIG. 11

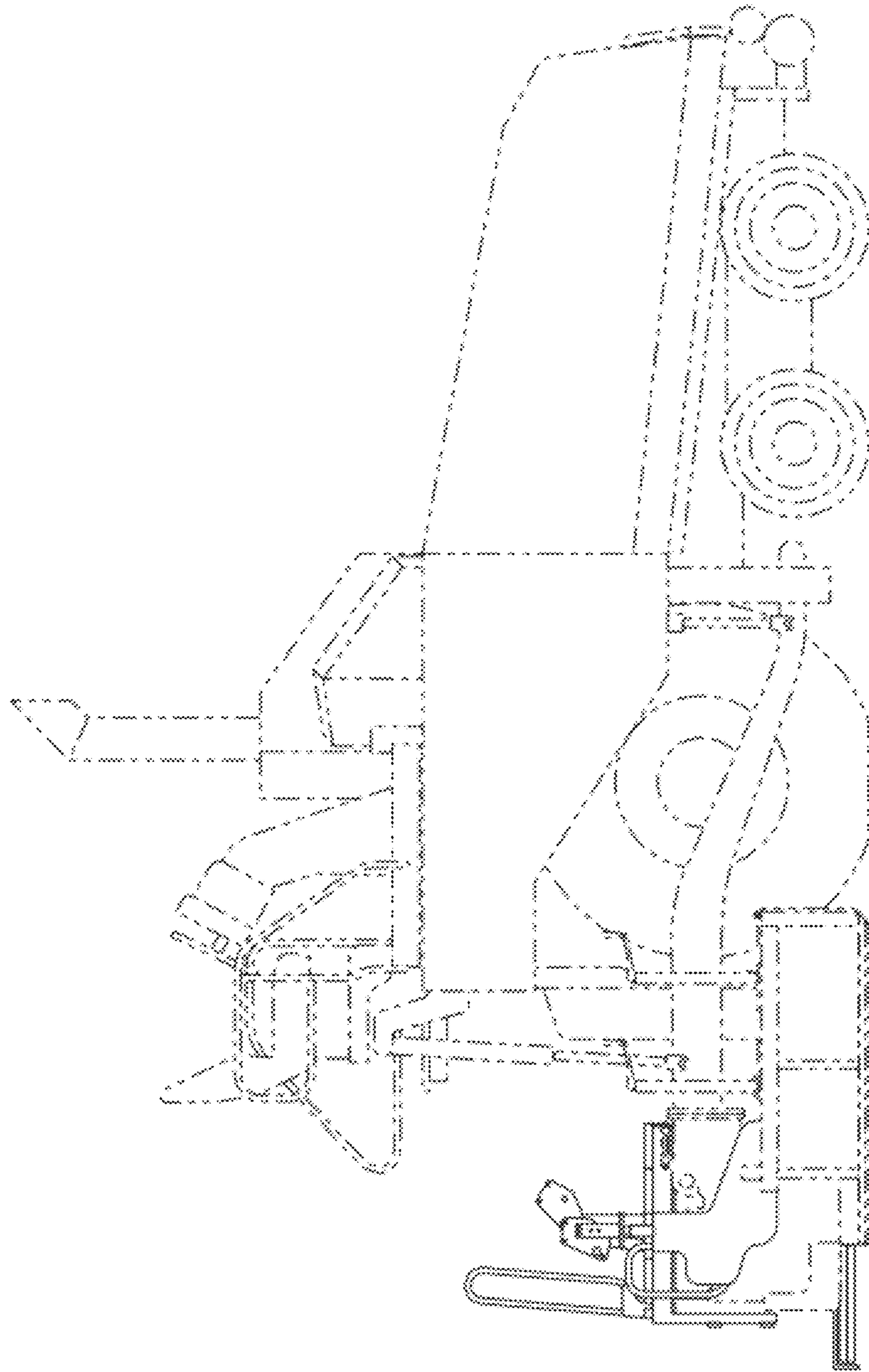

FIG. 12

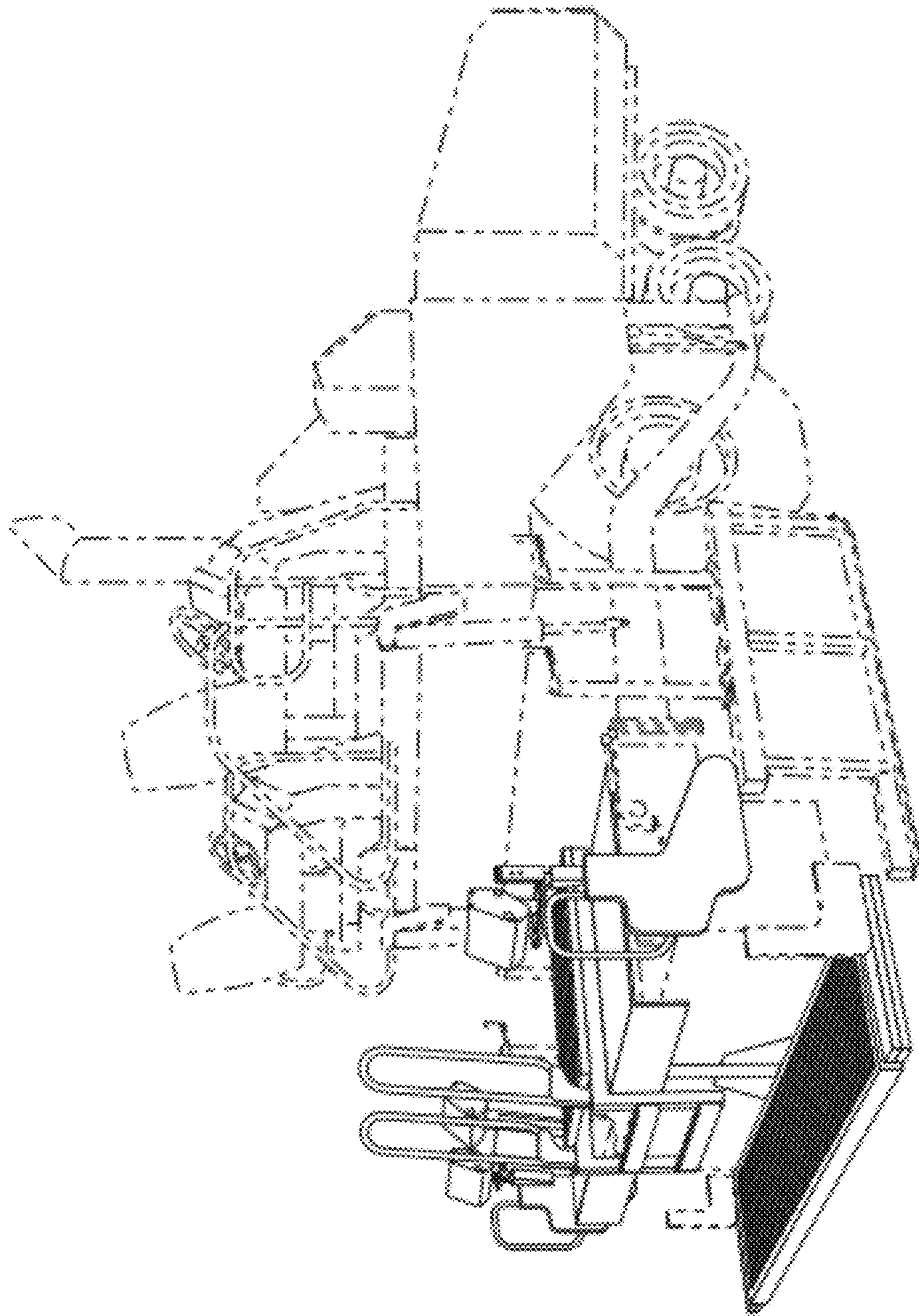

FIG. 13

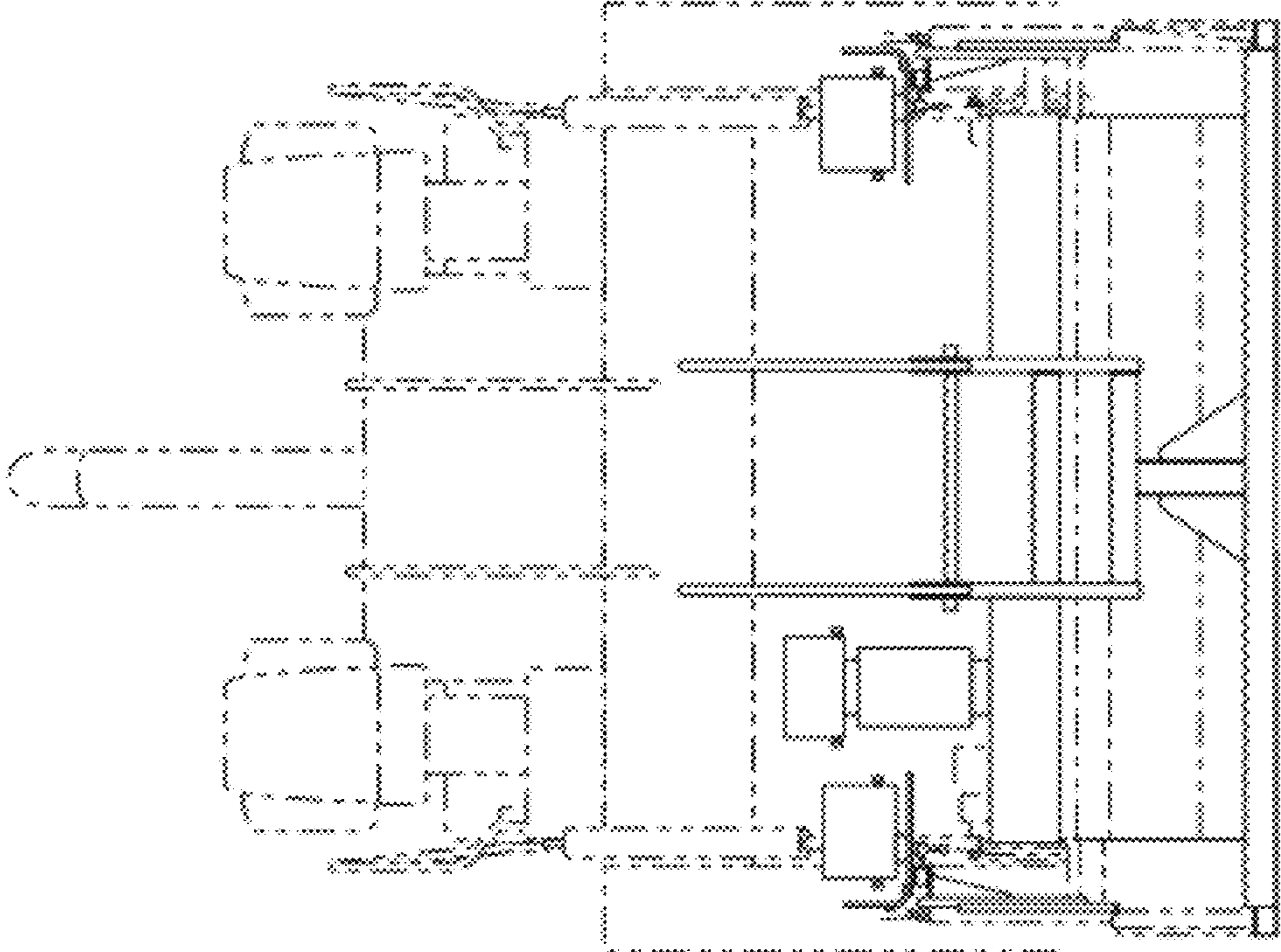

FIG. 14

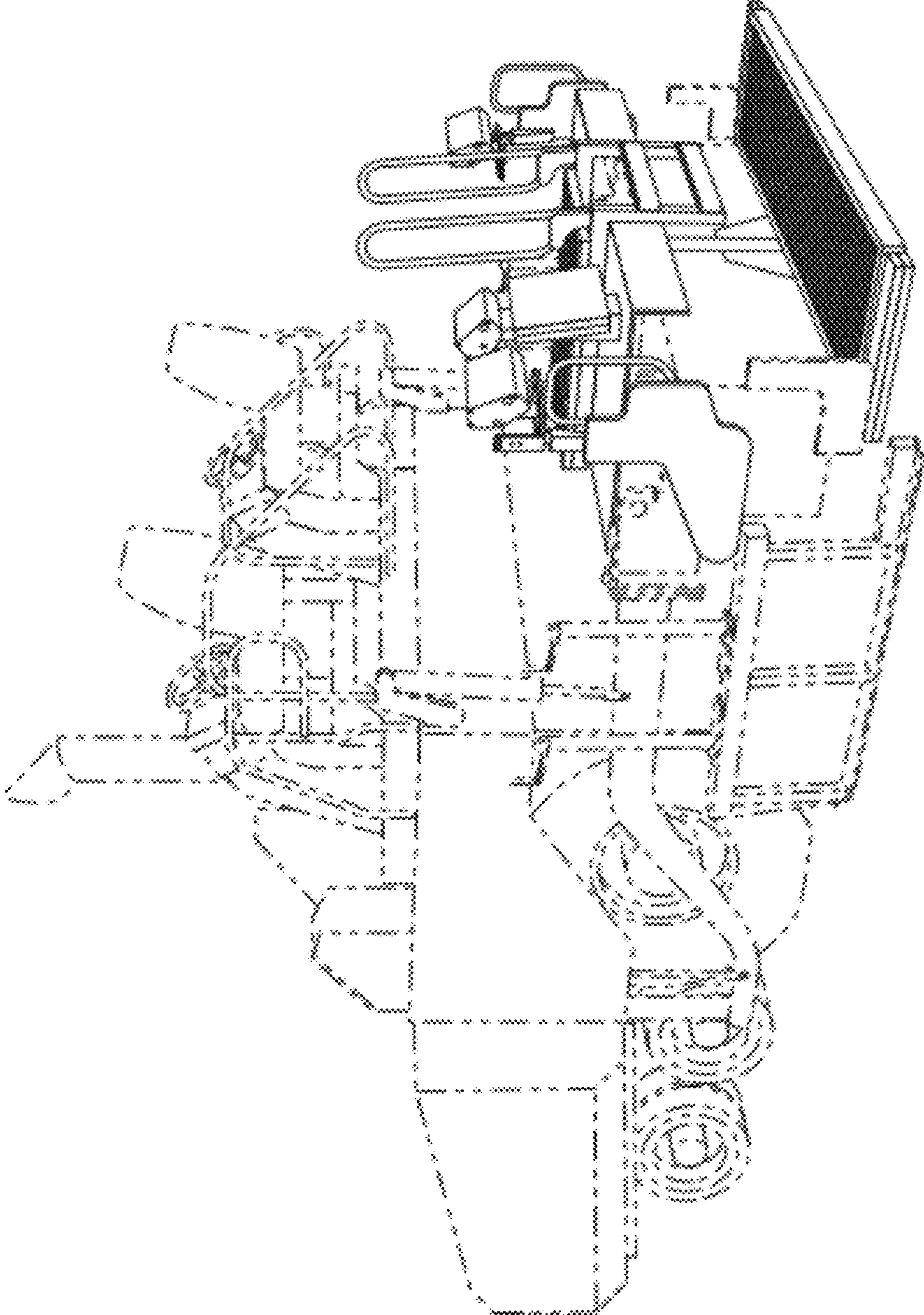

FIG. 15

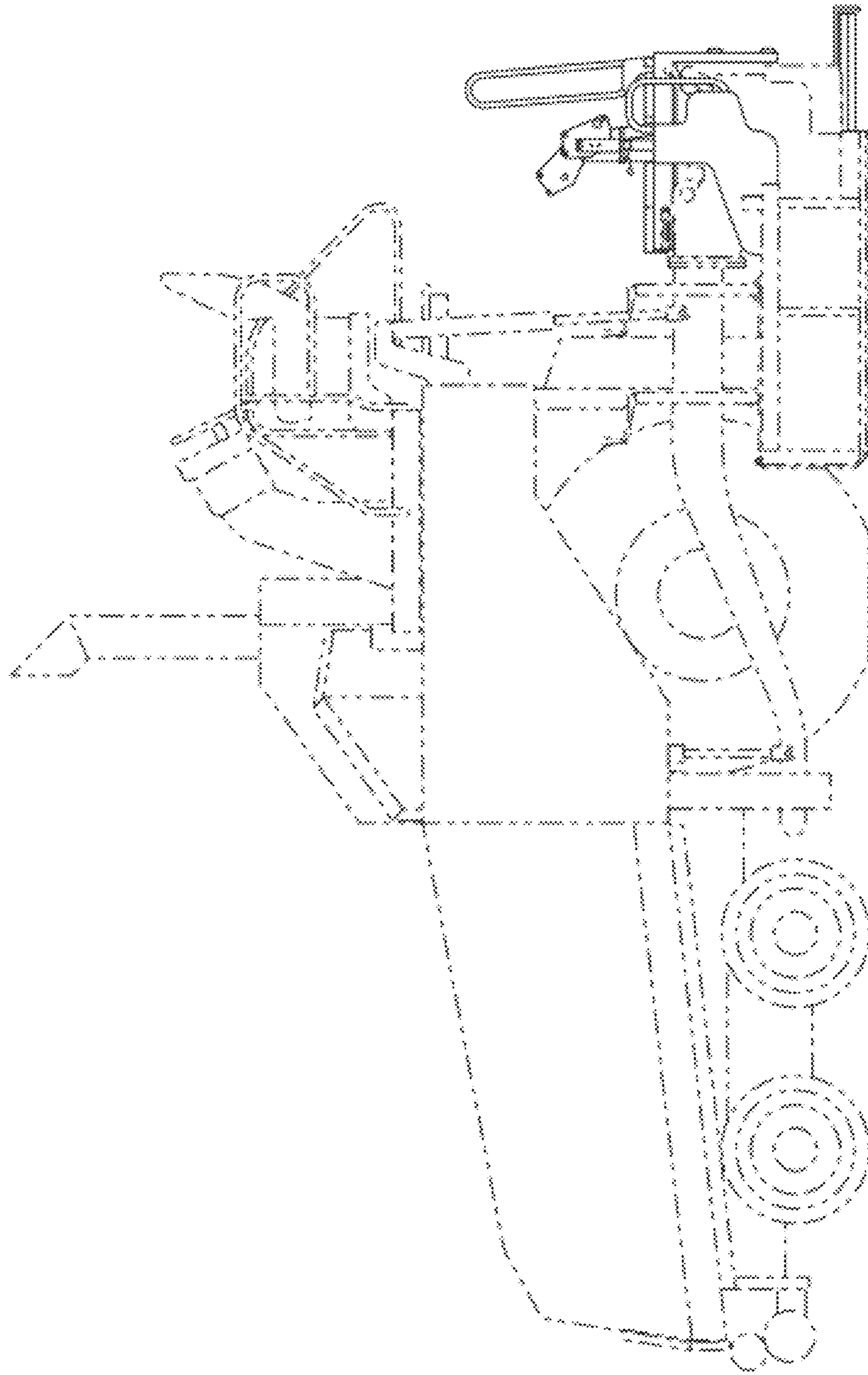

FIG. 16

FIG. 17

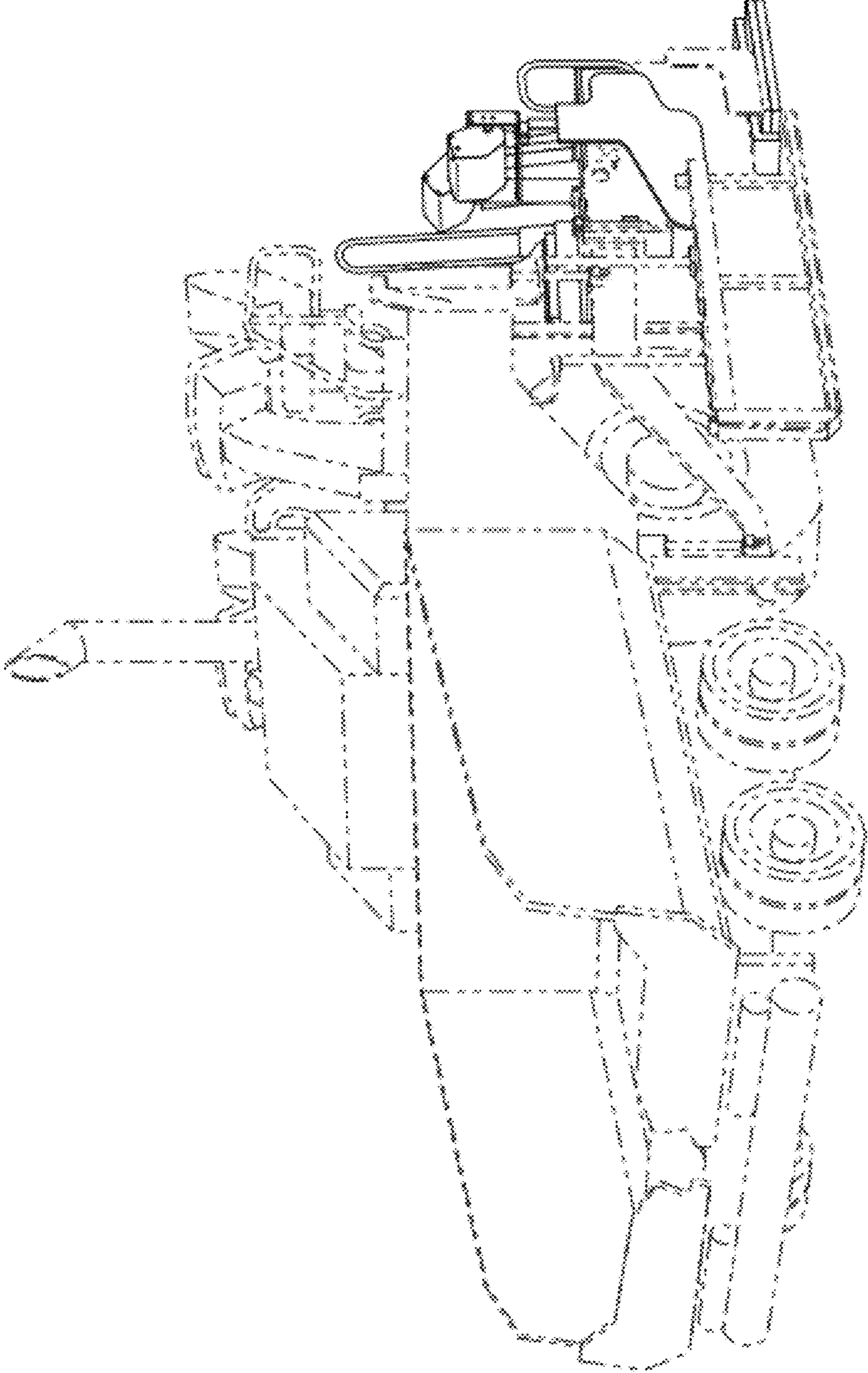

FIG. 18

