



US00D673491S

(12) **United States Design Patent**  
**Wang**

(10) **Patent No.:** **US D673,491 S**

(45) **Date of Patent:** **\*\* Jan. 1, 2013**

(54) **VEHICLE FLOOR MAT HAVING A LOWER WINTER MAT AND A REMOVABLE UPPER SUMMER MAT**

(76) Inventor: **Calvin Wang**, City of Industry, CA (US)

(\*\*) Term: **14 Years**

(21) Appl. No.: **29/428,350**

(22) Filed: **Jul. 30, 2012**

**Related U.S. Application Data**

(63) Continuation-in-part of application No. 29/348,324, filed on Dec. 22, 2009, now abandoned.

(51) **LOC (9) Cl.** ..... **12-16**

(52) **U.S. Cl.** ..... **D12/203**

(58) **Field of Classification Search** ..... D12/203;  
D6/582-586, 592-594; 280/163-164.1;  
15/215-217; 428/138.141; 296/97.23  
See application file for complete search history.

(56) **References Cited**

**U.S. PATENT DOCUMENTS**

D220,259 S *	3/1971	Gerber	.....	D12/203
D259,417 S *	6/1981	Bell et al.	.....	D12/203
D348,646 S *	7/1994	Reuben	.....	D12/203
D467,532 S *	12/2002	Kraines	.....	D12/203
D548,663 S *	8/2007	Thomas	.....	D12/203
D585,349 S *	1/2009	Mason	.....	D12/203
D610,958 S *	3/2010	Assil	.....	D12/203
D622,648 S *	8/2010	Lu	.....	D12/203
D632,626 S *	2/2011	Koblenzer	.....	D12/203

\* cited by examiner

*Primary Examiner* — Stacia Cadmus

(74) *Attorney, Agent, or Firm* — Albert O. Cota

(57) **CLAIM**

The ornamental design for a vehicle floor mat having a lower winter mat and a removable upper summer mat, as shown and described.

**DESCRIPTION**

FIG. 1 is a top plan view of a vehicle floor mat having a lower winter mat and a removable upper summer mat showing my new design;

FIG. 2 is a cross-sectional view thereof, taken along the lines 2-2 of FIG. 1;

FIG. 3 is a cross-sectional view thereof, taken along the lines 3-3 of FIG. 1;

FIG. 4 is a top plan view of the lower winter mat thereof, showing an outline of the upper summer mat and a plurality of male attachment studs;

FIG. 5 is a cross-sectional view thereof, taken along the lines 5-5 of FIG. 4;

FIG. 6 is a cross-sectional view thereof, taken along the lines 6-6 of FIG. 4;

FIG. 7 is a top plan view of the upper summer mat thereof, showing a plurality of eyelets in alignment with the plurality of said male attachment studs and an optional elevated foot pad;

FIG. 8 is a cross-sectional view thereof, taken along the lines 8-8 of FIG. 7;

FIG. 9 is a cross-sectional view thereof; taken along the lines 9-9 of FIG. 7; and,

FIG. 10 is an exploded view showing the removable upper summer mat prior to being attached to the lower winter mat.

**1 Claim, 4 Drawing Sheets**

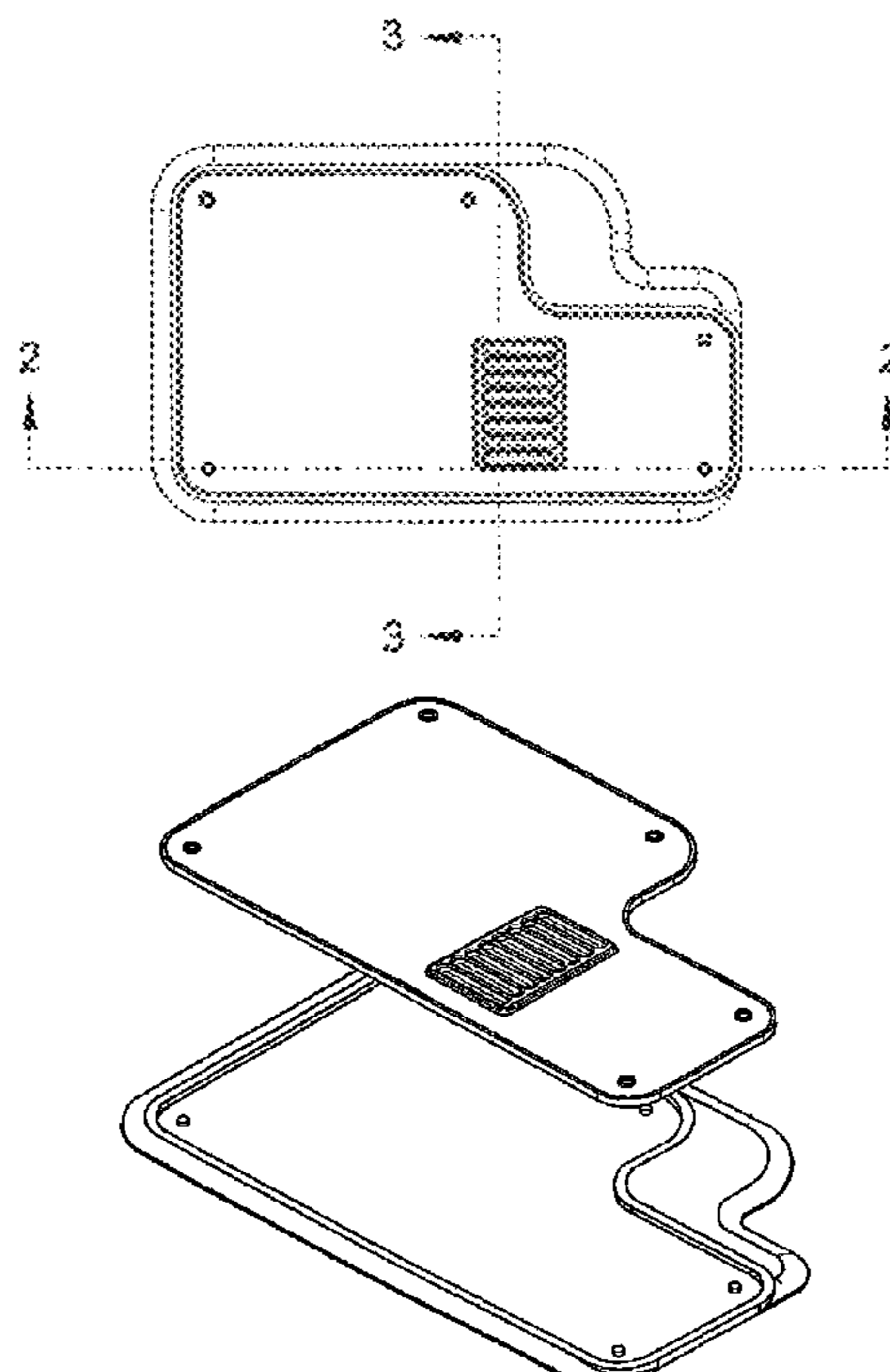

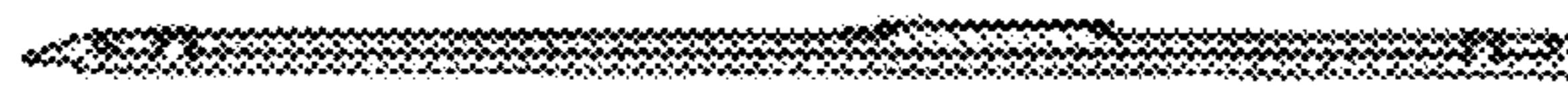
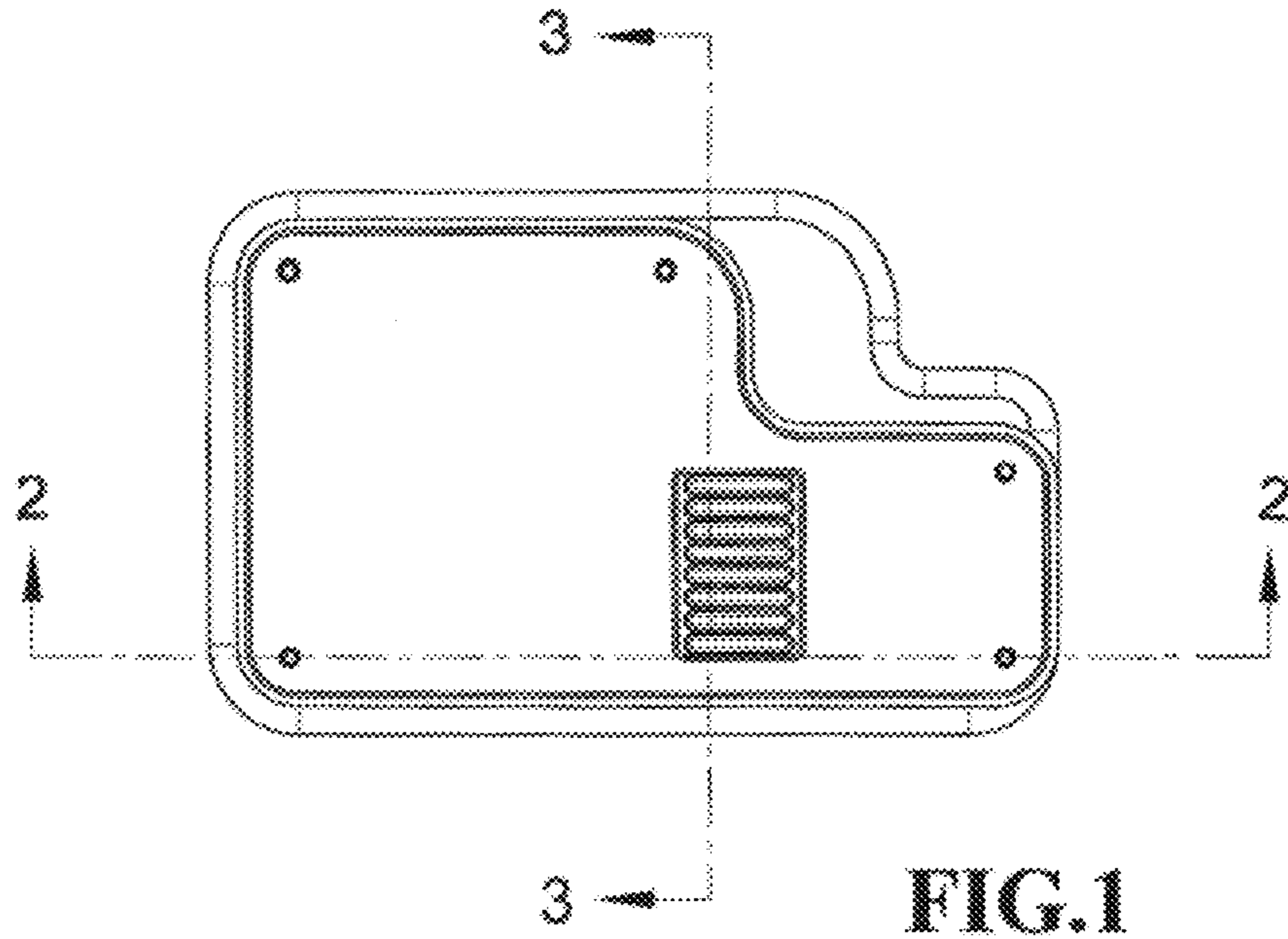

FIG. 2



FIG. 3

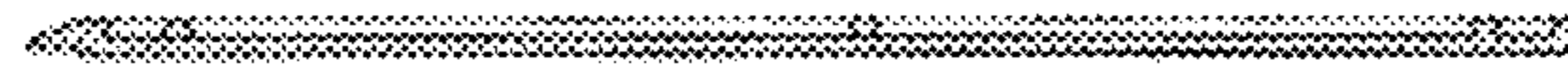
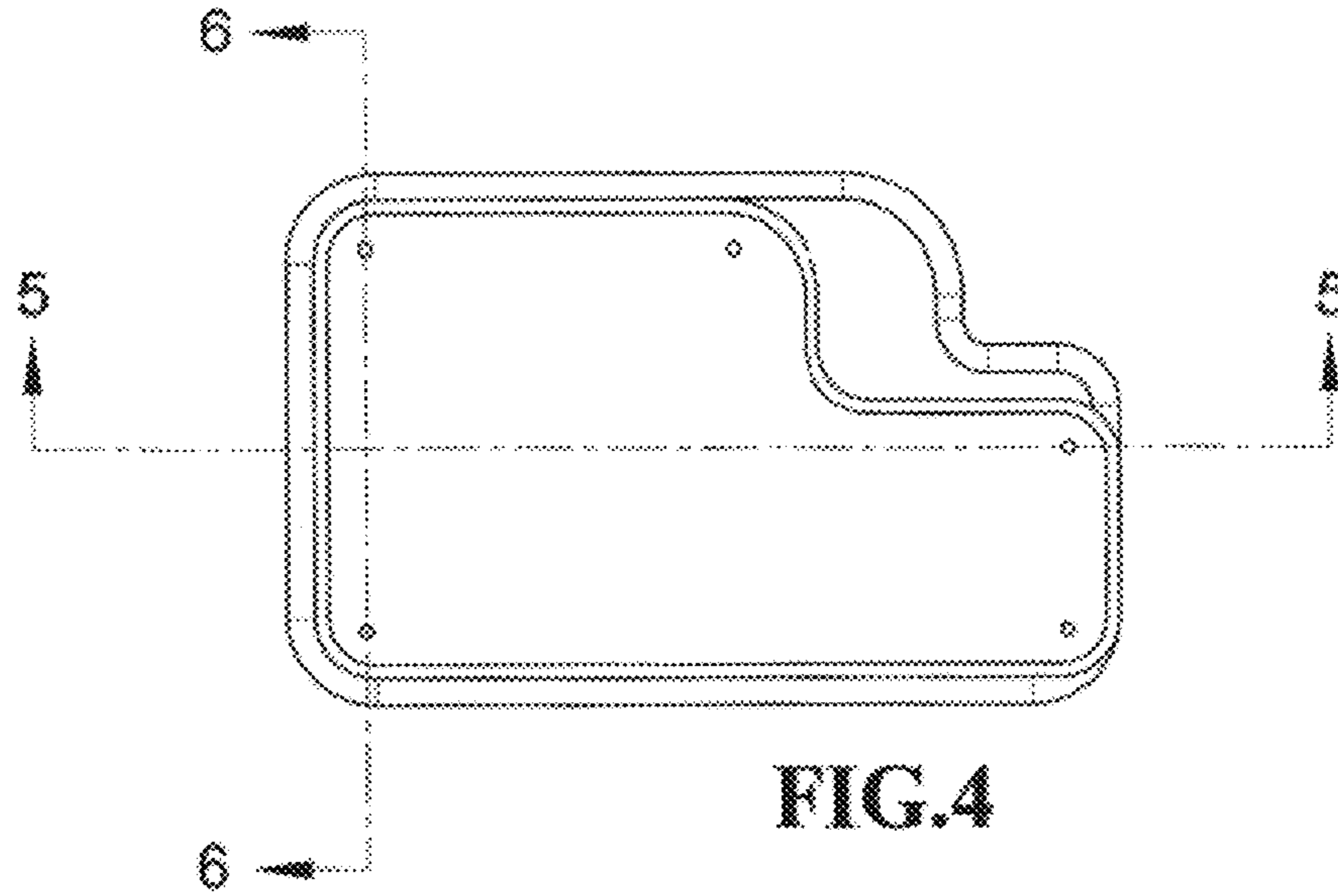

FIG. 5



FIG. 6

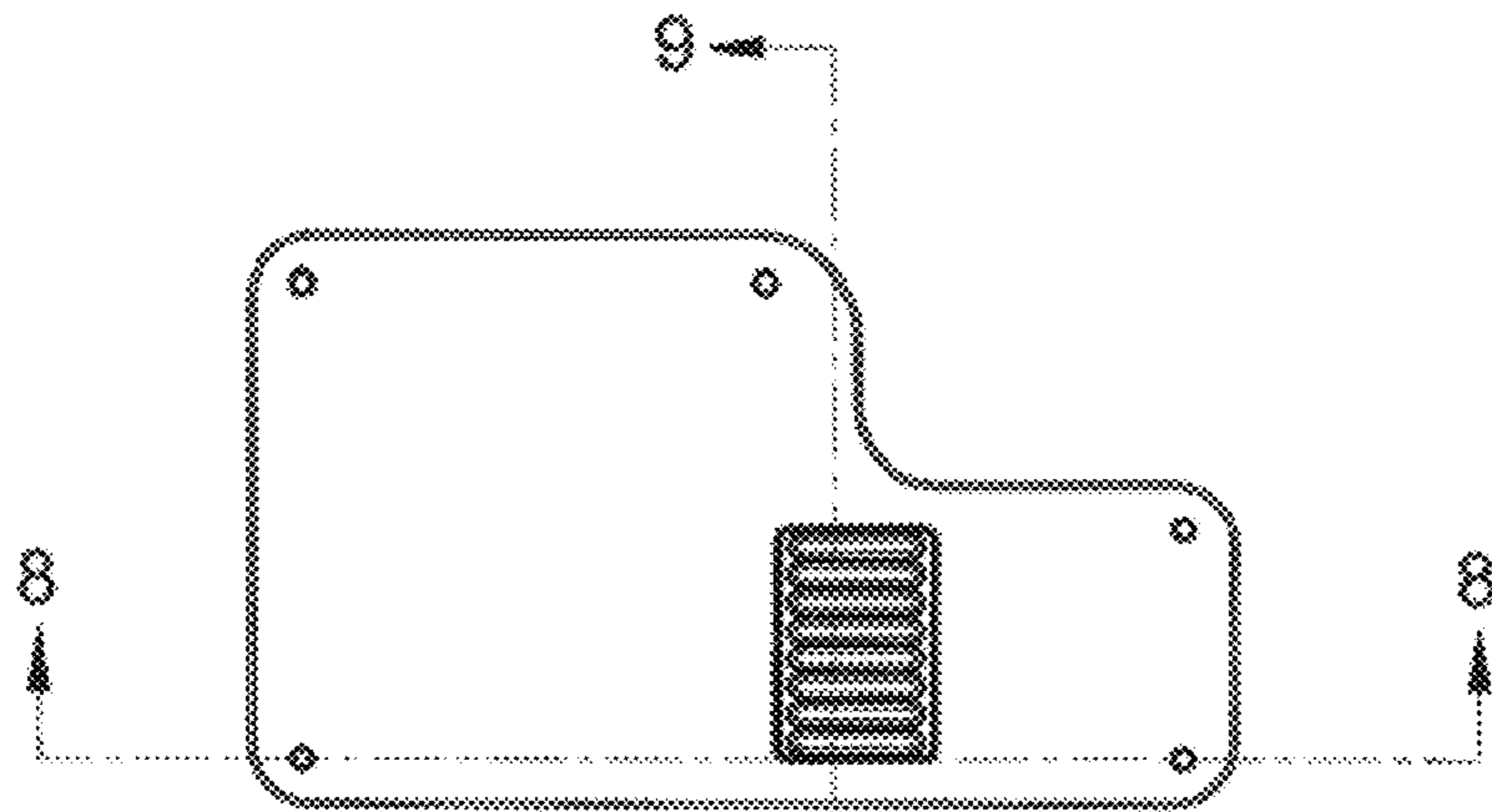

FIG. 7

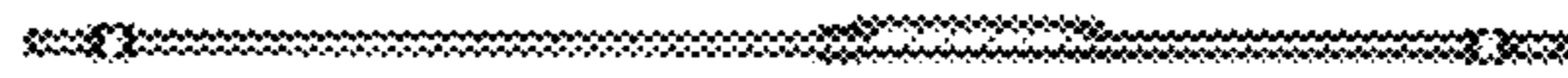

FIG. 8



FIG. 9

FIG.10

