



US00D673489S

(12) **United States Design Patent**
Hanson et al.

(10) **Patent No.:** **US D673,489 S**
(45) **Date of Patent:** **** Jan. 1, 2013**

- (54) **PORTIONS OF A TRUCK CAB**
- (75) Inventors: **Eric J. Hanson**, Valparaiso, IN (US);
Gary C. Bryant, Chillicothe, IL (US)
- (73) Assignee: **Caterpillar Inc.**, Peoria, IL (US)
- (**) Term: **14 Years**
- (21) Appl. No.: **29/411,241**
- (22) Filed: **Jan. 18, 2012**

- D504,642 S 5/2005 Perfetti et al.
- D523,793 S 6/2006 Beigel
- D536,287 S 2/2007 Beigel et al.
- D537,761 S 3/2007 Beigel et al.
- D540,725 S 4/2007 Gunter et al.
- D556,654 S 12/2007 Lee et al.
- D571,696 S 6/2008 Rosen et al.
- D589,846 S 4/2009 Tanaka
- D605,986 S * 12/2009 Raghavendran et al. D12/163
- D621,756 S * 8/2010 Angelo et al. D12/184
- D627,692 S * 11/2010 Cheng D12/163
- D628,134 S * 11/2010 Salnick et al. D12/196
- D631,800 S * 2/2011 Peltola et al. D12/163
- D654,417 S * 2/2012 Peltola et al. D12/196

(Continued)

Related U.S. Application Data

- (62) Division of application No. 29/381,435, filed on Dec. 20, 2010, now Pat. No. Des. 655,227.
- (51) **LOC (9) Cl.** **12-16**
- (52) **U.S. Cl.** **D12/196**
- (58) **Field of Classification Search** D12/163,
D12/196, 171, 216, 90-92, 86; 180/68.1,
180/68.6; 296/193.11
See application file for complete search history.

OTHER PUBLICATIONS

Photograph of 2009 Ford Work Truck, F650/F750, http://www.comtruck.ford.com/pdf/brochures/MediumDuty_Catalog.pdf, Accessed May 6, 2010 prior to Application Filing Date.

(Continued)

Primary Examiner — Melody N Brown

(74) *Attorney, Agent, or Firm* — Finnegan, Henderson, Farabow, Garrett & Dunner LLP

(56) **References Cited**

U.S. PATENT DOCUMENTS

- D307,126 S 4/1990 Allendorph et al.
- D328,273 S 7/1992 McGrew, Jr. et al.
- D335,272 S 5/1993 Allendorph et al.
- D366,638 S 1/1996 Tucker et al.
- D367,027 S 2/1996 Onopa et al.
- D382,841 S 8/1997 Norwood et al.
- D391,908 S 3/1998 Allendorph et al.
- D394,035 S 5/1998 Stosel et al.
- D394,624 S 5/1998 Allendorph et al.
- D412,689 S 8/1999 Onopa
- D426,800 S 6/2000 Zimmerman
- D437,574 S 2/2001 Beigel
- D450,277 S 11/2001 Onopa
- D455,381 S 4/2002 Maher et al.
- D458,197 S 6/2002 Maher et al.
- D466,450 S 12/2002 Maher et al.
- D502,897 S 3/2005 Delashaw et al.
- D502,901 S 3/2005 Delashaw et al.

(57) **CLAIM**

The ornamental design for a portions of a truck cab, as shown and described.

DESCRIPTION

FIG. 1 is a front right perspective view of portions of a truck cab showing our new design; FIG. 2 is a right side view thereof; FIG. 3 is a top view thereof; FIG. 4 is a front view thereof; and, FIG. 5 is a back right perspective view thereof. The broken lines of the figures showing additional portions of the truck are included for the purpose of illustrating environmental structure and form no part of the claimed design.

1 Claim, 5 Drawing Sheets

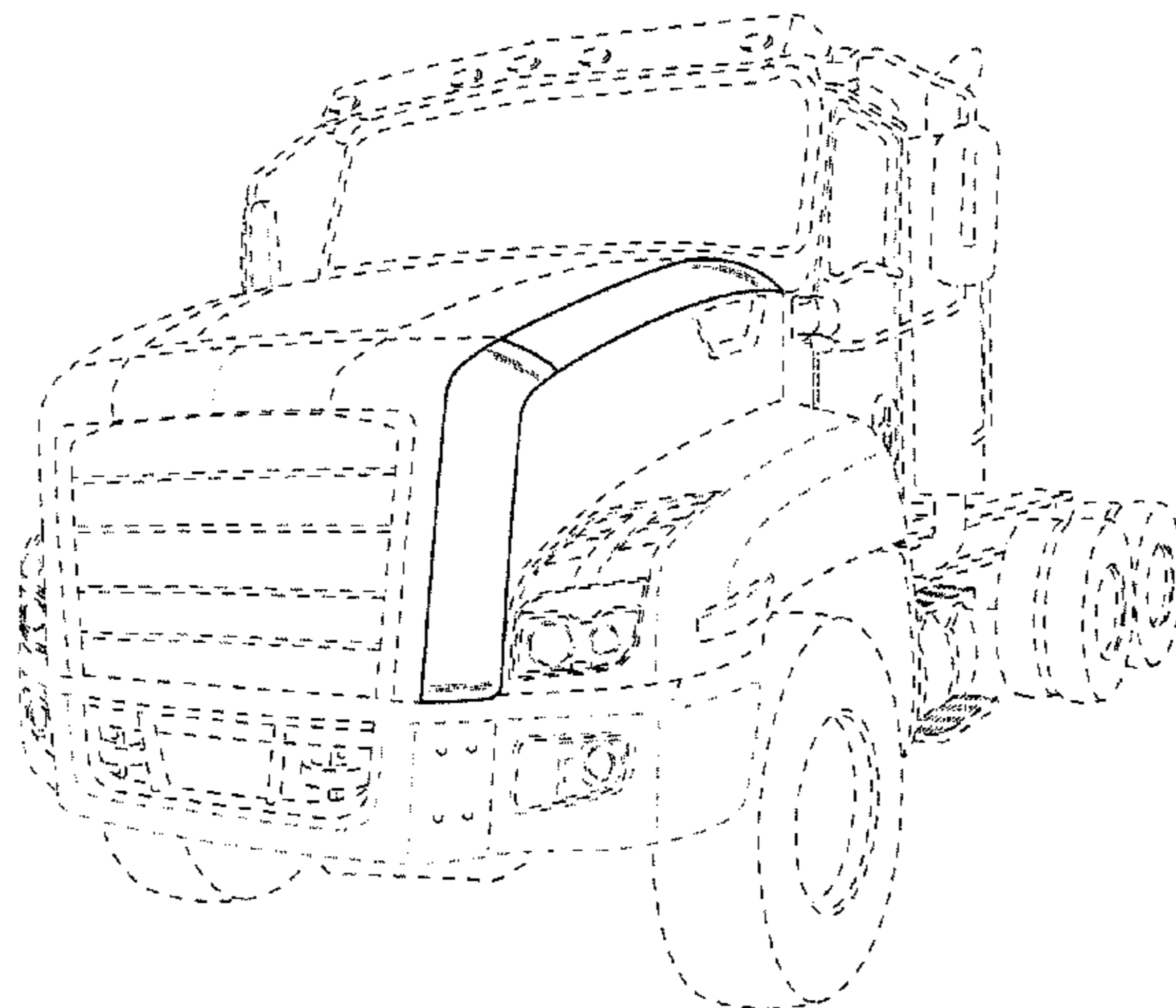

U.S. PATENT DOCUMENTS

D655,226 S * 3/2012 Hanson et al. D12/163
D655,227 S * 3/2012 Hanson et al. D12/173

OTHER PUBLICATIONS

Photograph of 2005 Ford F150 Lariat, <http://dustinsfordtruck.com/Documents/Pictures.html>, Accessed May 6, 2010 prior to Application Filing Date.

Photograph of 2010 GMC Sierra 1500 Truck, <http://www.pickupsplus.com/370>, Accessed: May 6, 2010 prior to Application Filing Date.

Photograph of 2010 GMC Terrain, http://www.cars.com/go/features/autoshow/vehicle.jsp?vehicletype=production&autoshowyear=2009&vehicle=production_gmc_terrain, Accessed: May 6, 2010 prior to Application Filing Date.

Photograph of 2007 GMC Topkick "Ironhide", <http://www.autoweek.com/article/20070726/FREE/70725006>, Accessed May 6, 2010, prior to Application Filing Date.

Photograph of 2007 International CXT, <http://www.cargurus.com/Cars/Pictures-c16490-pi35667819-2007-CXT.html>, Accessed May 6, 2010, prior to Application Filing Date.

Photograph of 2007 Toyota Tundra, <http://reviews.carreview.com/blog/2007toyota-tundra-review-big-trucks-make-big-impressions/>, Accessed May 6, 2010 prior to Application Filing Date.

Photograph of 2010 Peterbilt 348, <http://www.peterbilt.com/voc348.1.aspx>, Accessed May 6, 2010, prior to Application Filing Date.

Photograph of 2010 Peterbilt 587, <http://www.peterbilt.com/aero587.1.aspx>, Accessed May 6, 2010, prior to Application Filing Date.

Photograph of 2010 Mack Granite Model, <http://www.mackgranite.com/>, Accessed May 6, 2010, prior to Application Filing Date.

Photograph of 2010 Navistar Transtar, <http://internationaltrucks.com/Trucks/Trucks/Series/TranStar>, Accessed May 6, 2010, prior to Application Filing Date.

Photograph of 2010 Navistar Workstar, <http://www.internationaltrucks.com/Trucks/Trucks/Series/WorkStar>, Accessed May 6, 2010, prior to Application Filing Date.

Photograph of 2010 Navistar Prostar+, <http://www.internationaltrucks.com/Trucks/Trucks/Series/ProStar>, Accessed May 6, 2010, prior to Application Filing Date.

Photograph of 2011 Hino Trucks (for North America), http://www.hino.com/trucks/story_874.php, Accessed May 6, 2010, prior to Application Filing Date.

Photograph of Bell B35D Articulated Truck, MK VI, <http://www.bellequipment.com/live/internet/homepage.nsf/0/304071492?OpenDocument>, Accessed May 6, 2010, prior to Application Filing Date.

Photograph of Terex TA30 Articulated Truck, <http://www.terex.com/attachment.php?action=LAUNCH&nav=prod&id=8bd46ee794d7d7c40e965941c5463448>, Accessed May 6, 2010, prior to Application Filing Date.

* cited by examiner

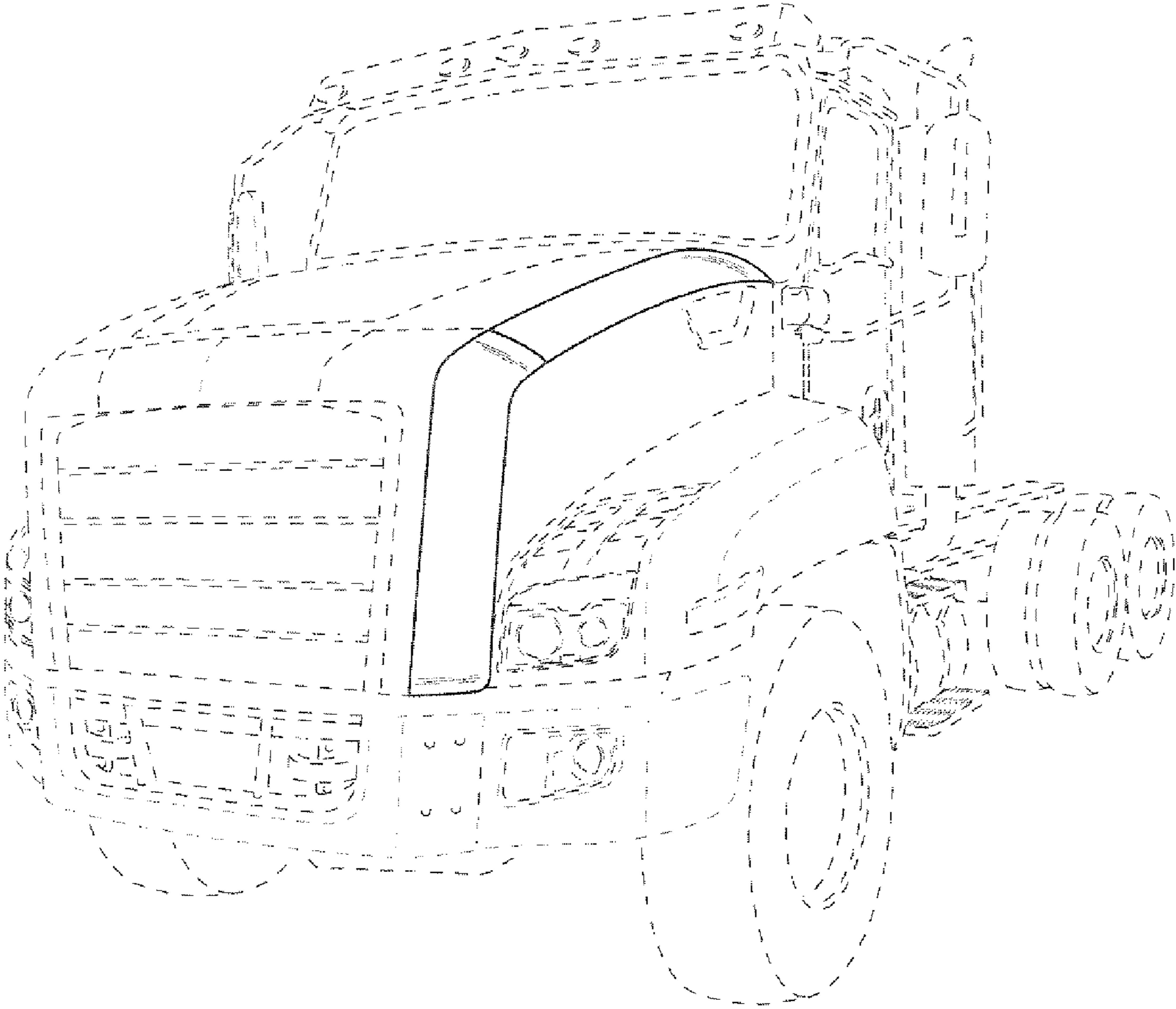

FIG. 1

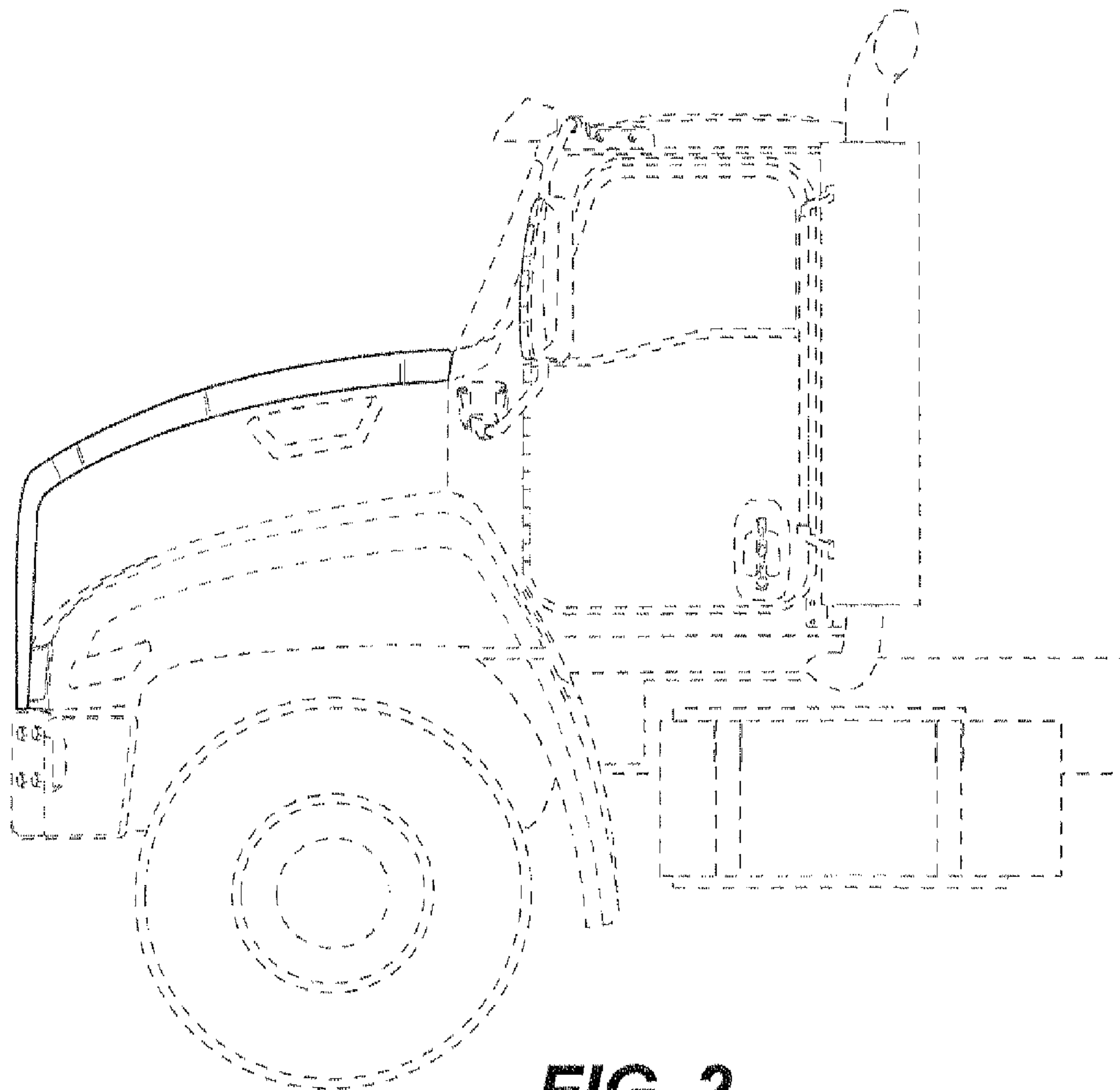

FIG. 2

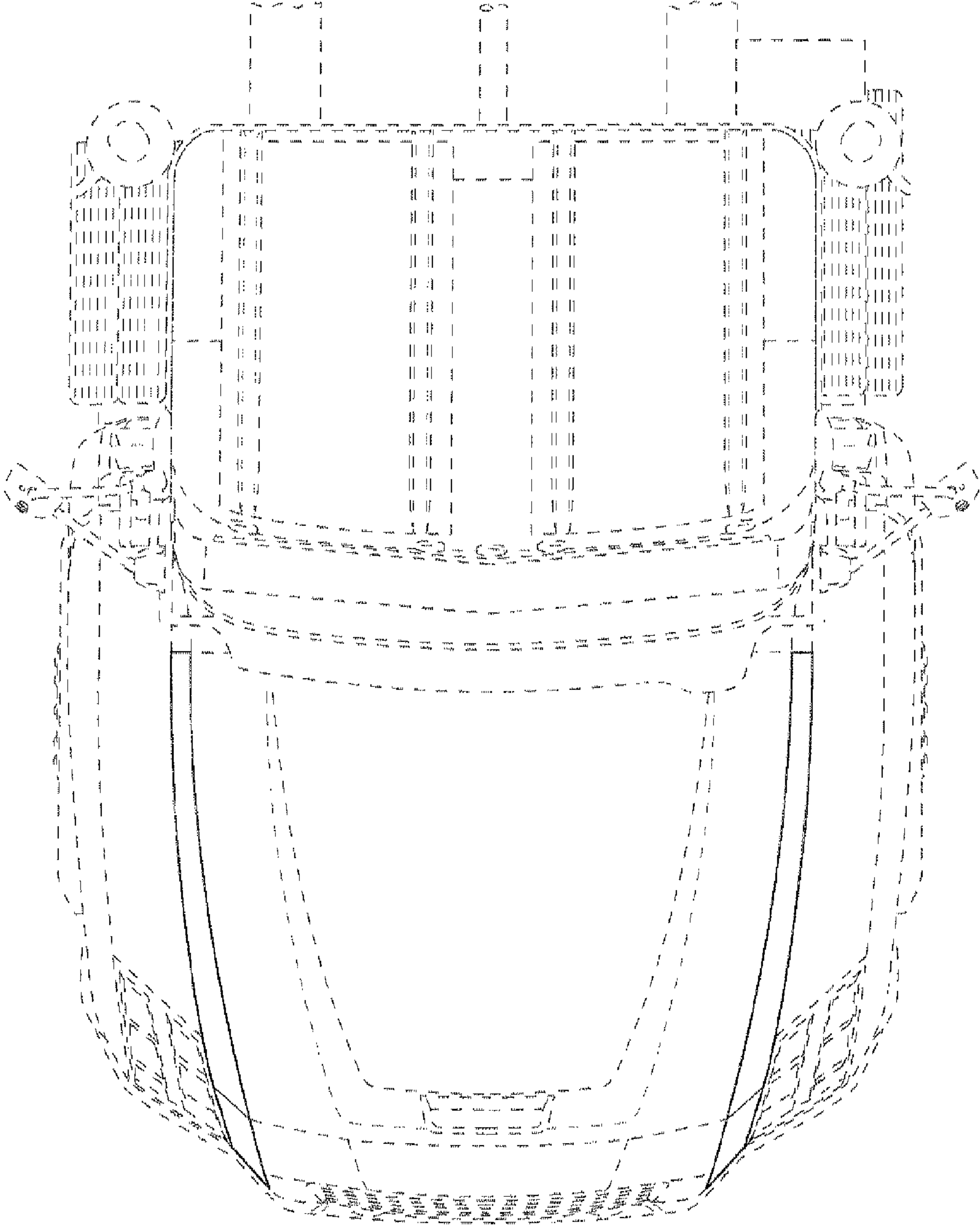

FIG. 3

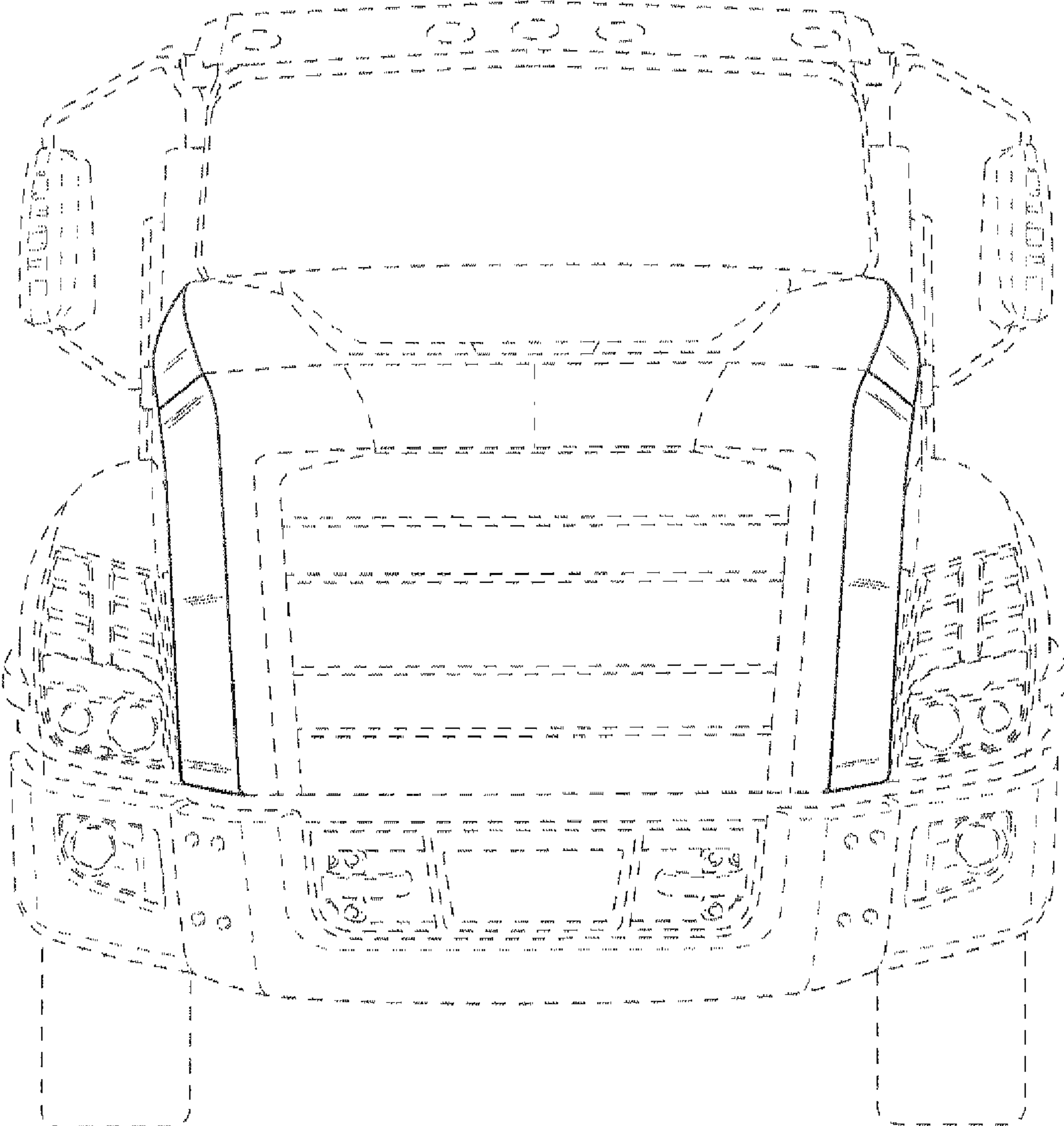

FIG. 4

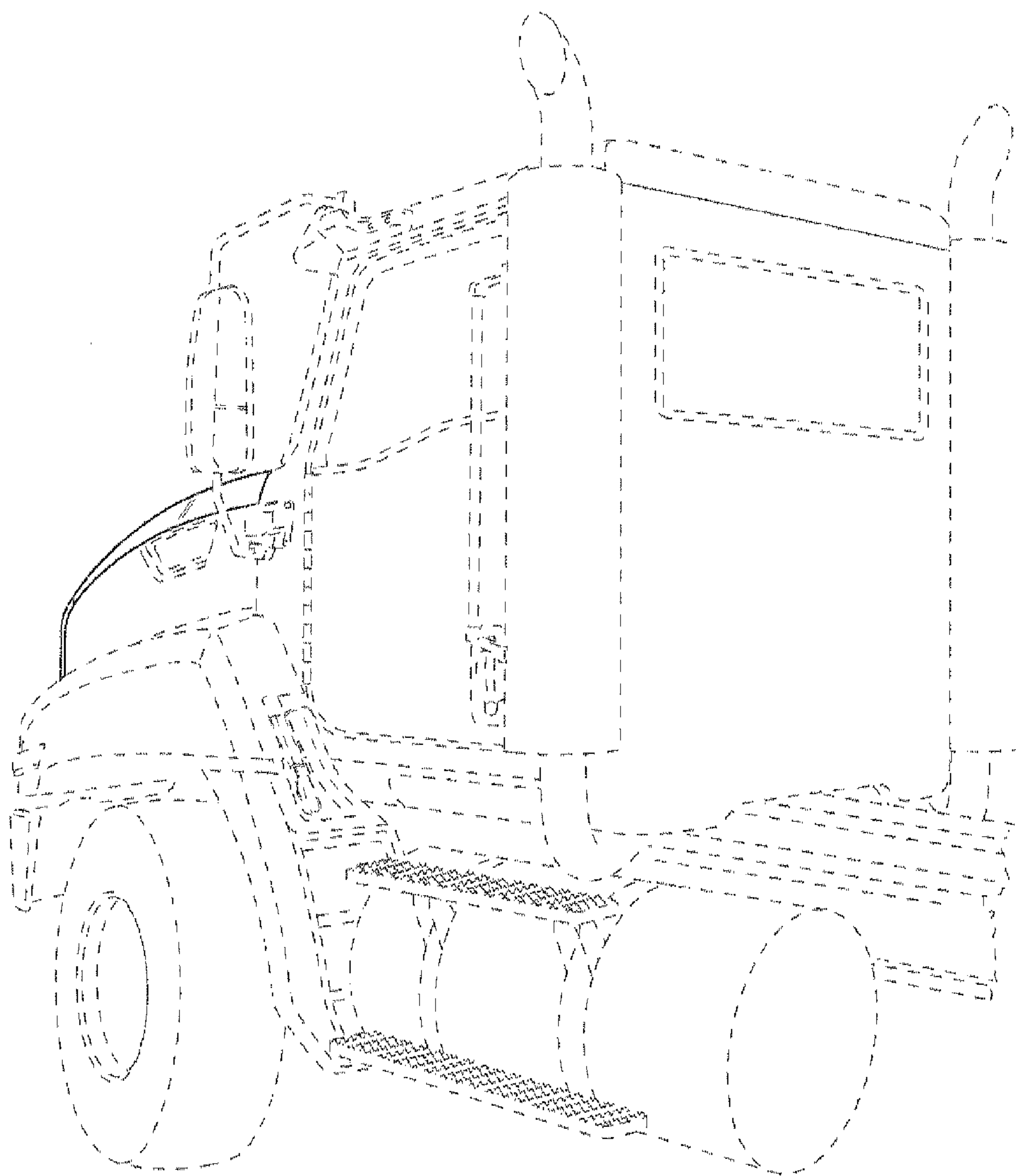

FIG. 5