



US00D673239S

(12) **United States Design Patent**  
**Cheng**

(10) **Patent No.:** **US D673,239 S**

(45) **Date of Patent:** **\*\* Dec. 25, 2012**

(54) **MULTIPLE RAIL FOR SIGHTING DEVICE**

(76) Inventor: **Carson Cheng**, Industry, CA (US)

(\*\*) Term: **14 Years**

(21) Appl. No.: **29/374,279**

(22) Filed: **Jul. 22, 2011**

(51) **LOC (9) Cl.** ..... **22-01**

(52) **U.S. Cl.** ..... **D22/109**

(58) **Field of Classification Search** ..... D22/100,  
D22/108-110, 199; 42/11, 72, 90, 85, 71.01,  
42/75.02, 106, 113-114, 124-125, 127-128;  
248/201, 205.1

See application file for complete search history.

(56) **References Cited**

**U.S. PATENT DOCUMENTS**

D291,470	S	*	8/1987	Bechtel	.....	D22/110
D383,826	S	*	9/1997	Weigand	.....	D22/110
5,826,363	A	*	10/1998	Olson	.....	42/75.01
D445,475	S	*	7/2001	Spear	.....	D22/108
D544,564	S	*	6/2007	Swan	.....	D22/108
D579,511	S	*	10/2008	Norberg et al.	.....	D22/110
7,870,688	B1	*	1/2011	Dasiukevich	.....	42/124

2005/0229465	A1	*	10/2005	Dextraze	.....	42/85
2009/0101776	A1	*	4/2009	Peterson et al.	.....	248/205.1
2010/0154280	A1	*	6/2010	LaFrance et al.	.....	42/124
2011/0107644	A1	*	5/2011	Faifer	.....	42/75.02
2011/0185617	A1	*	8/2011	Brixius	.....	42/71.01

\* cited by examiner

*Primary Examiner* — Michael A Pratt

(74) *Attorney, Agent, or Firm* — Raymond Y. Chan; David and Raymond Patent Firm

(57) **CLAIM**

The ornamental design for a multiple rail for sighting device, as shown and described.

**DESCRIPTION**

FIG. 1 is a front perspective view of multiple rail for sighting device showing my new design;  
FIG. 2 is a front view thereof;  
FIG. 3 is a rear view thereof;  
FIG. 4 is a left end view thereof;  
FIG. 5 is a right end view thereof;  
FIG. 6 is a top view thereof; and,  
FIG. 7 is a bottom view thereof.

**1 Claim, 7 Drawing Sheets**

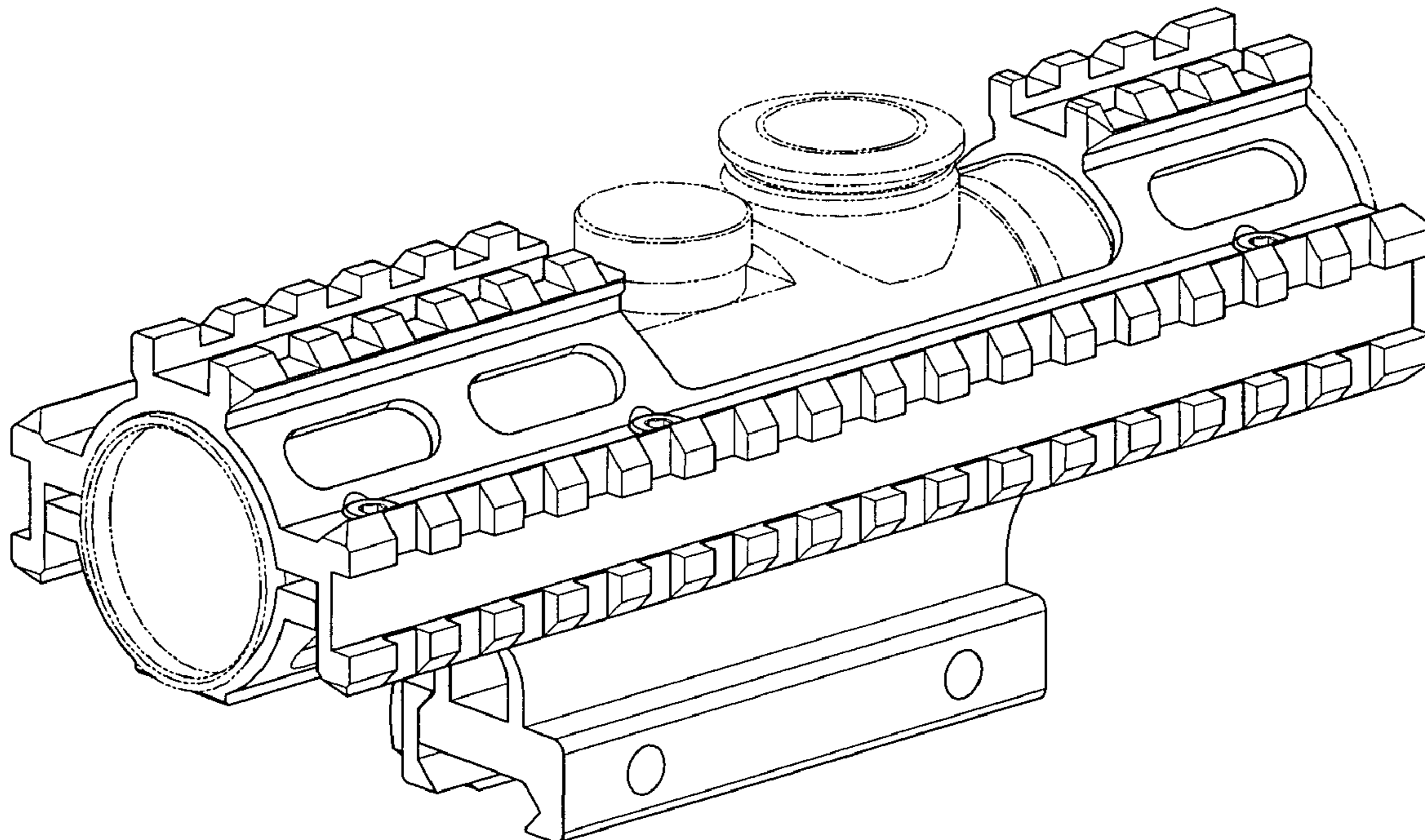

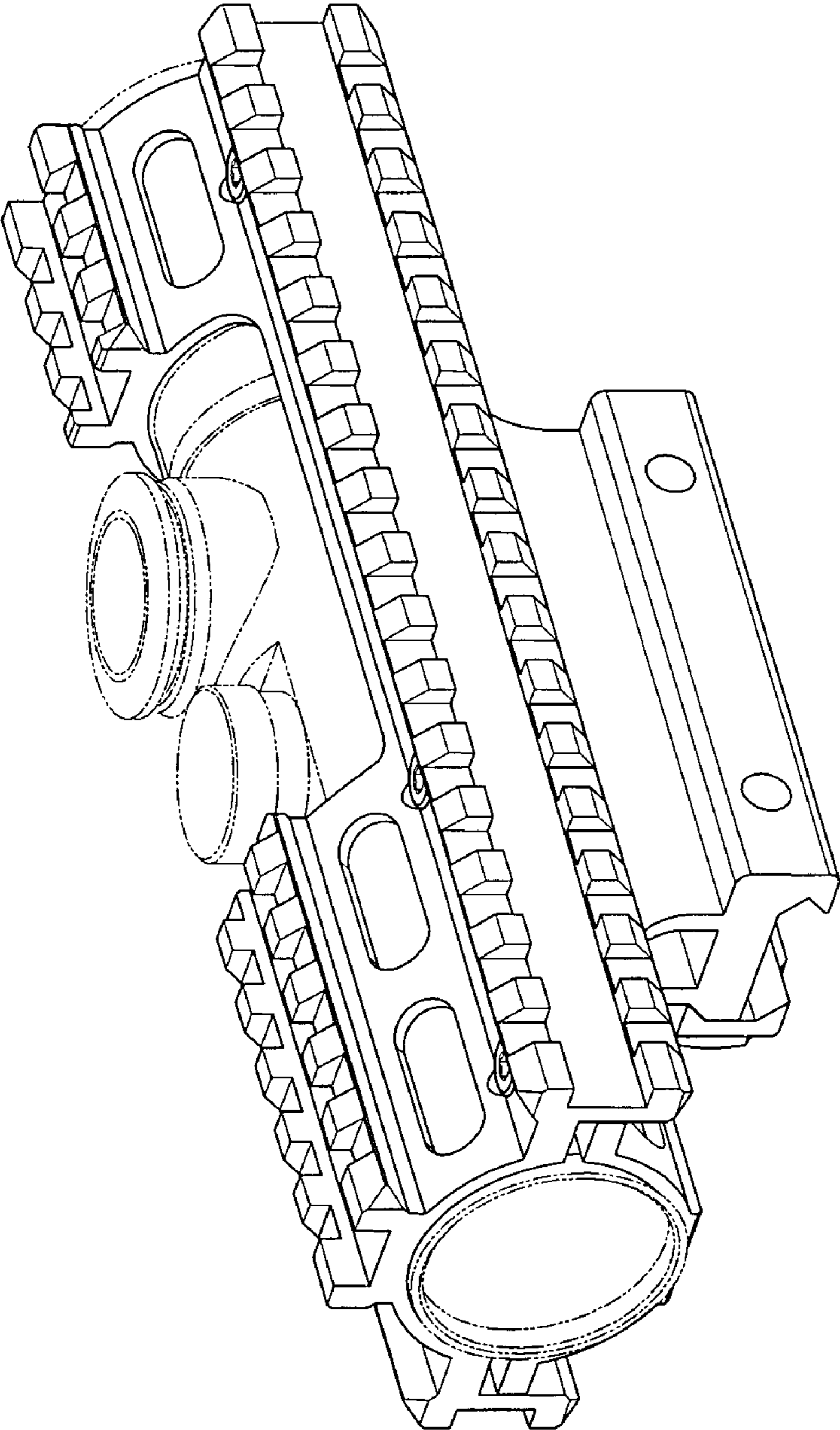

FIG. 1

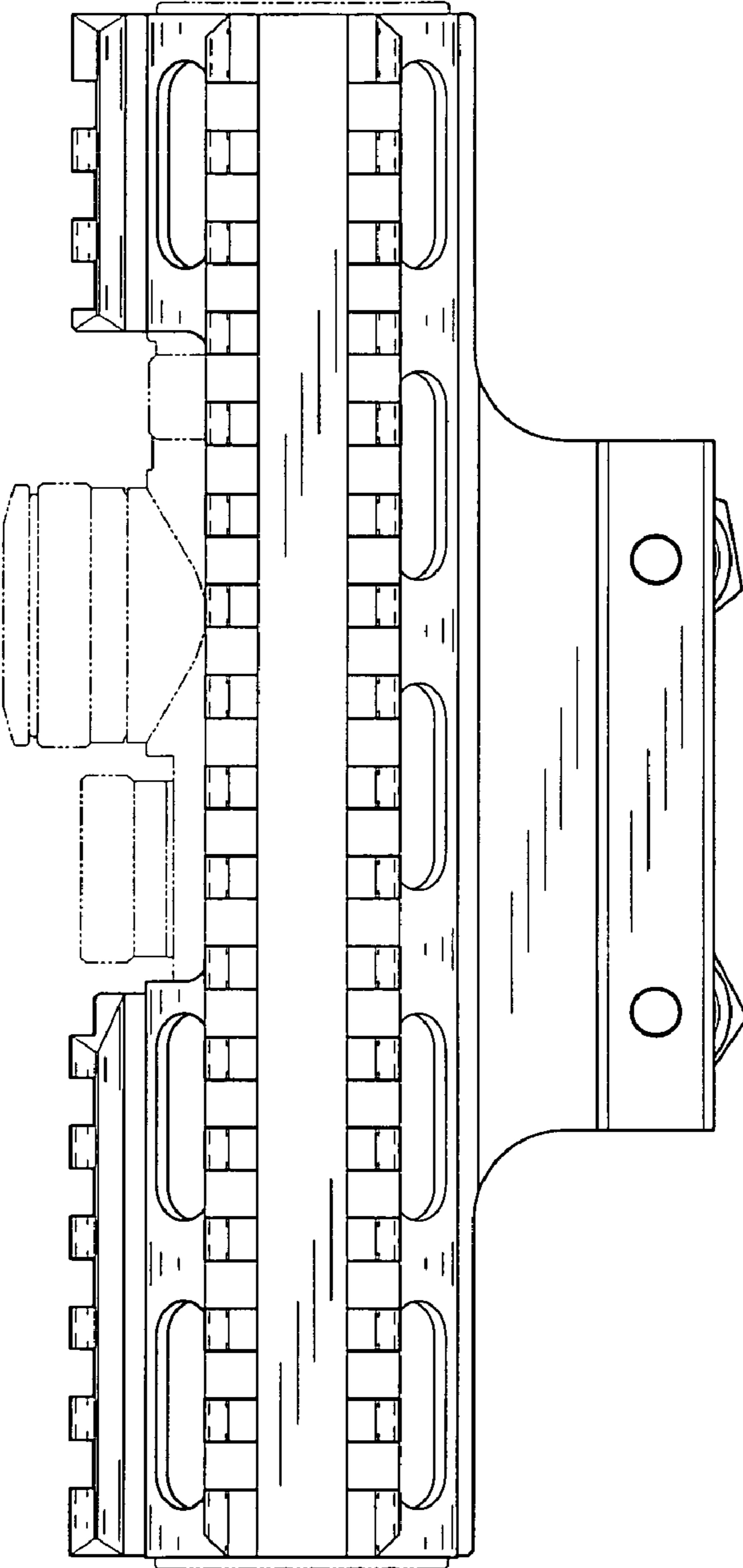

FIG. 2

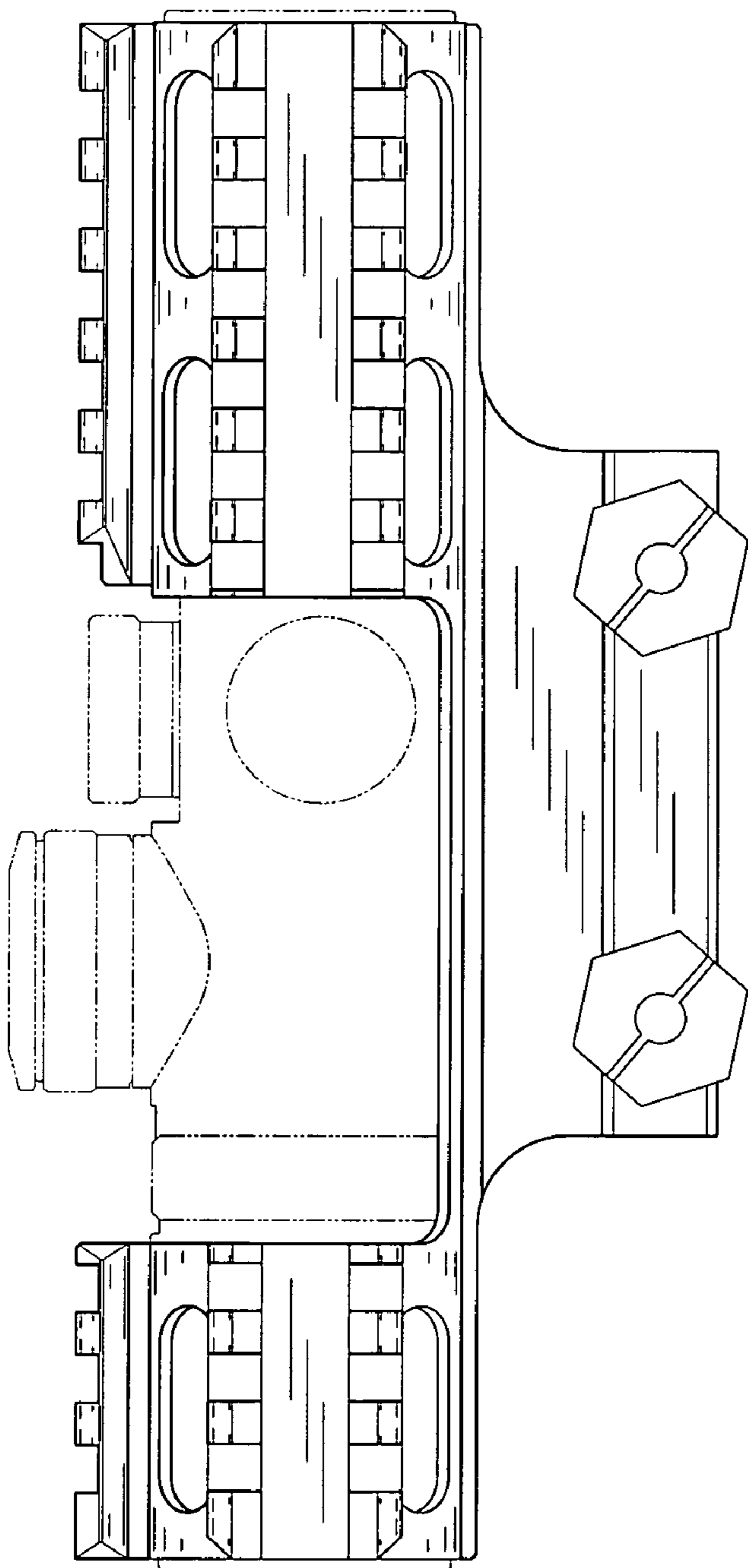

FIG. 3

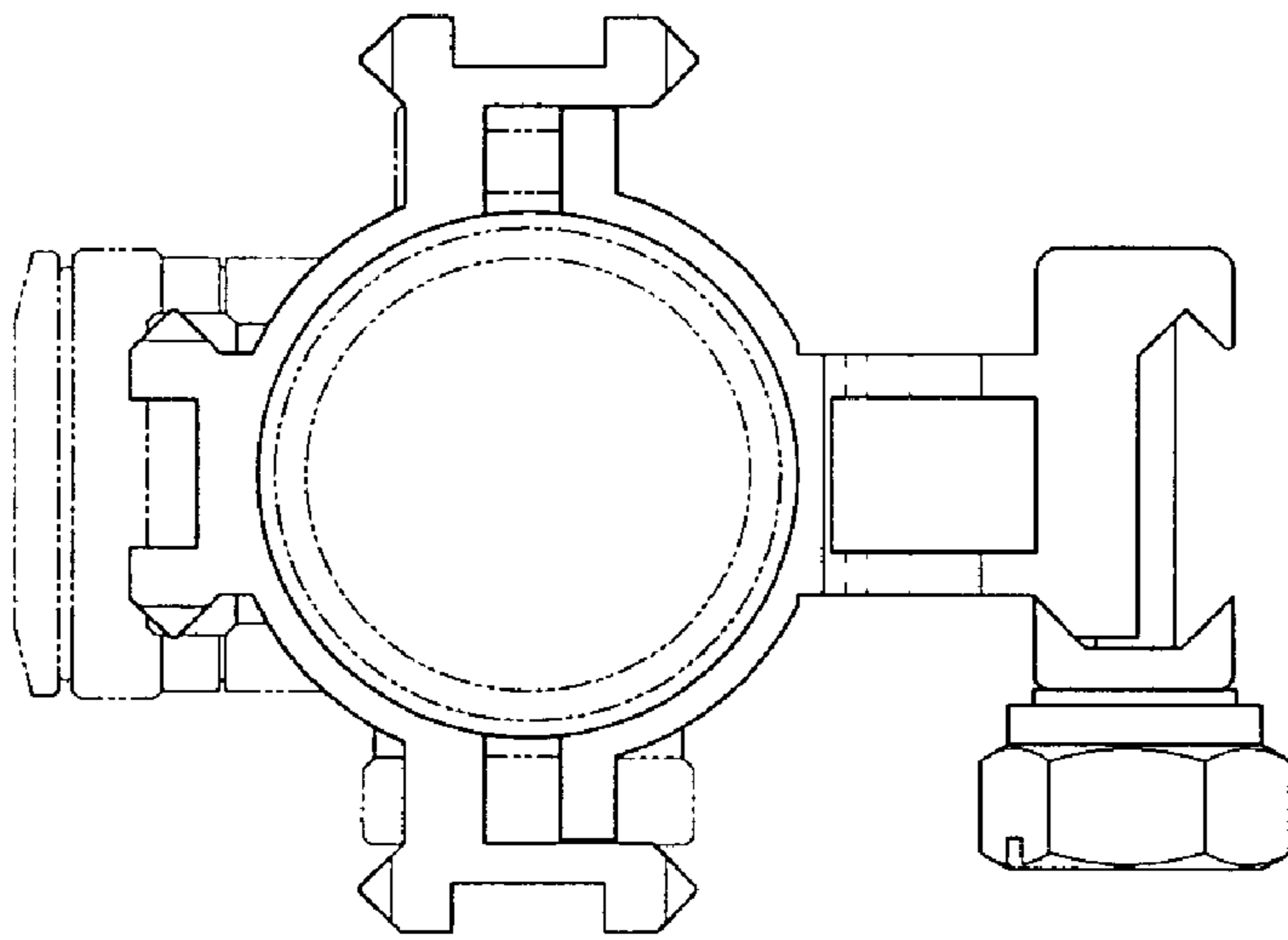

FIG. 4

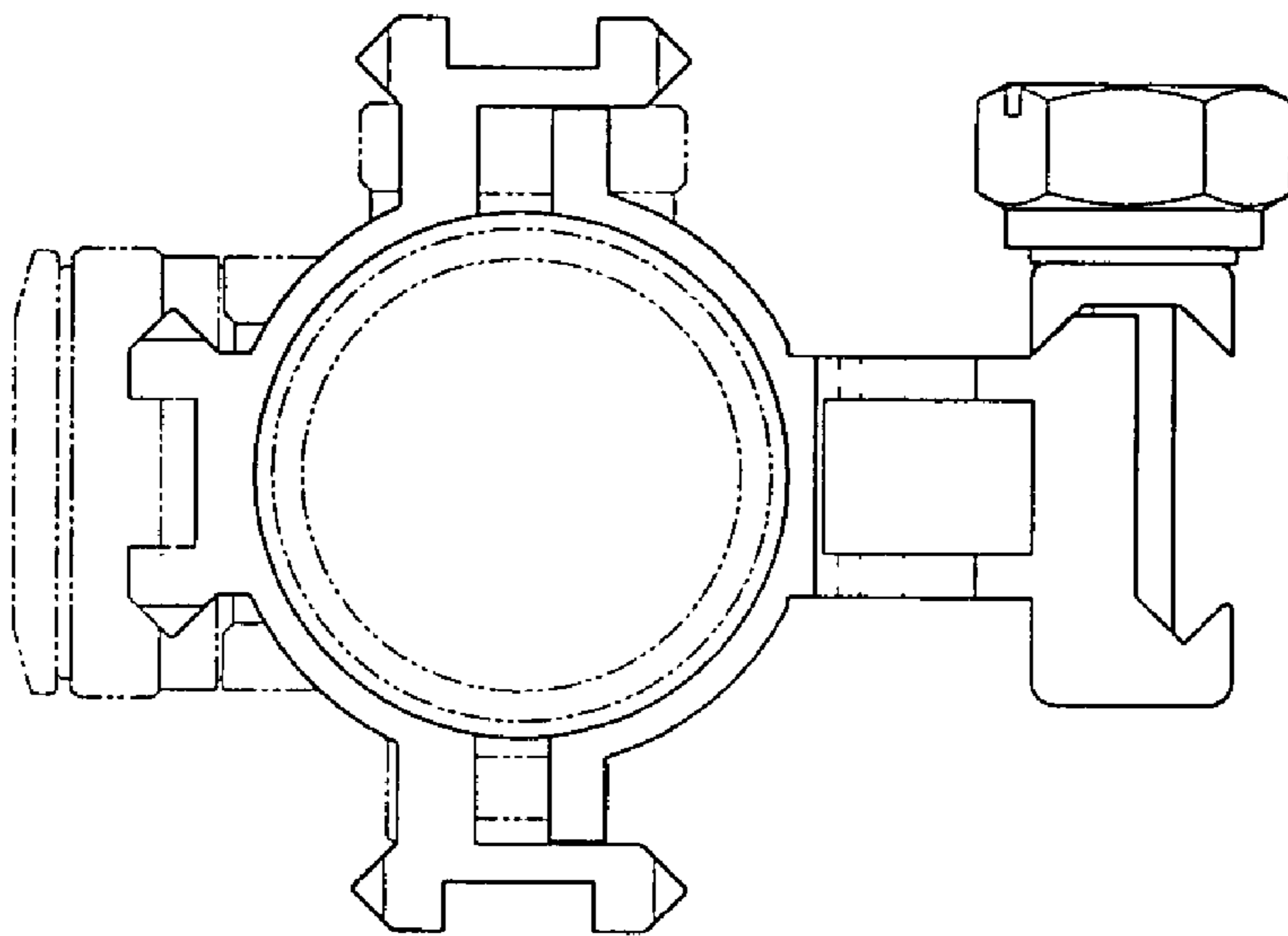

FIG. 5



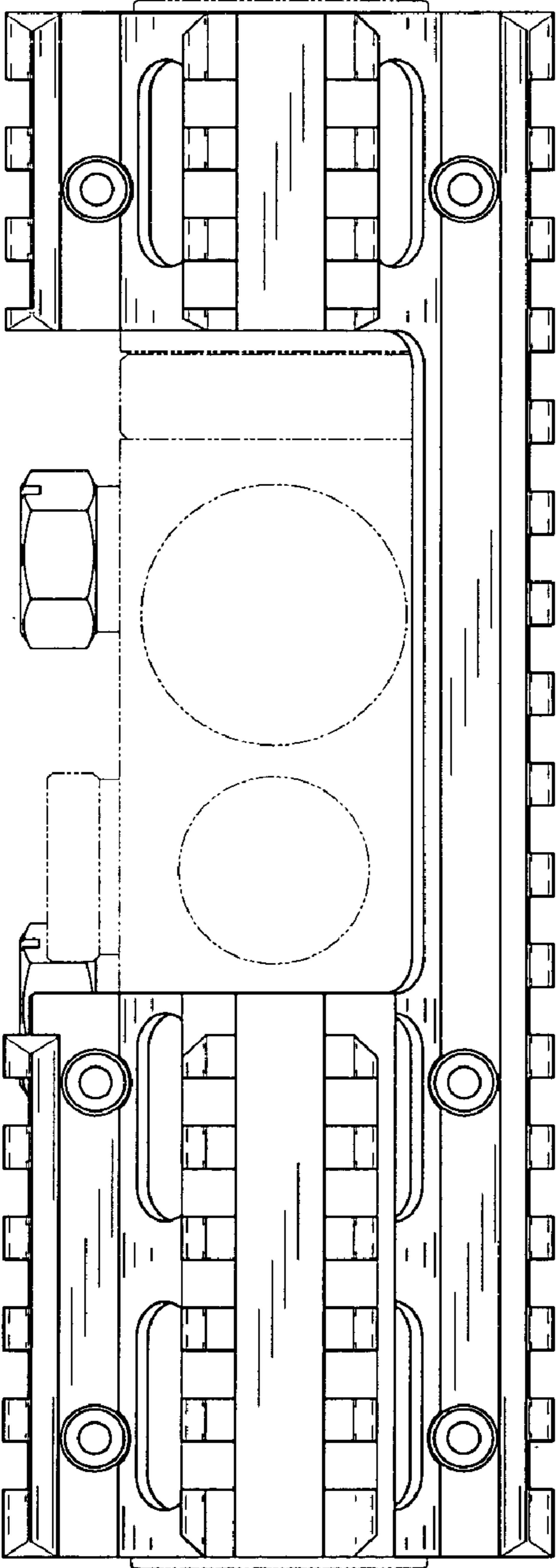

FIG. 6

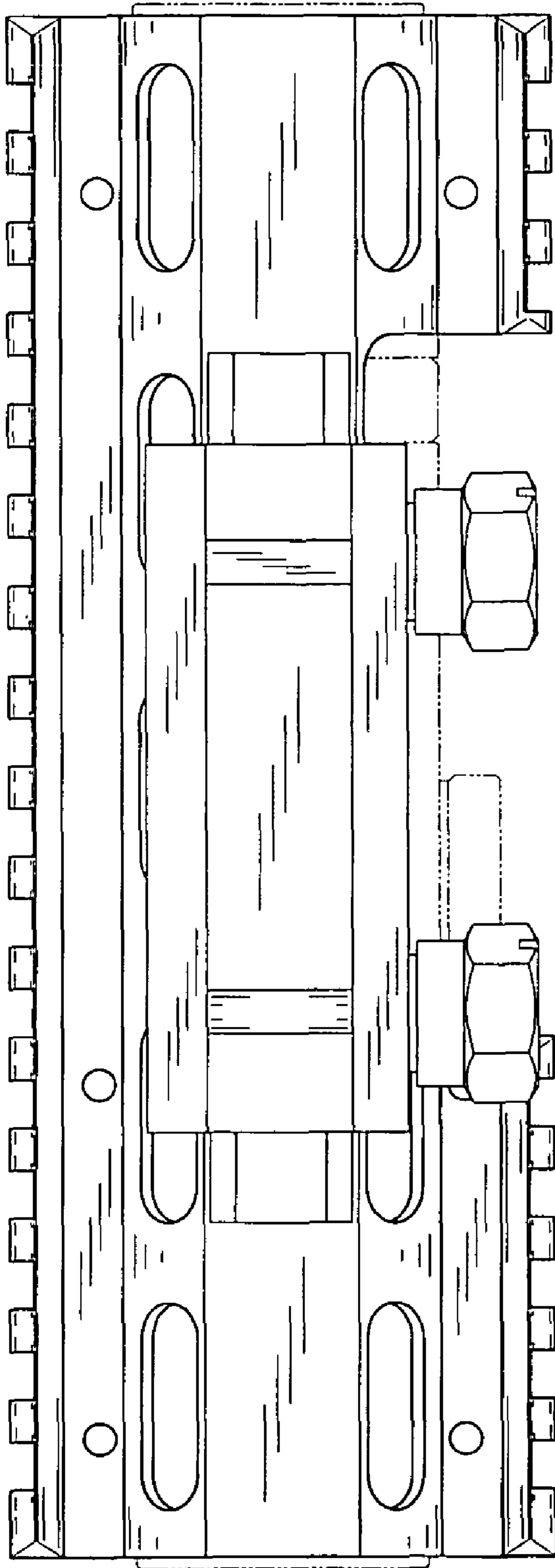

FIG. 7