



US00D673106S

(12) **United States Design Patent**  
**Rossman et al.**

(10) **Patent No.:** **US D673,106 S**

(45) **Date of Patent:** **\*\* Dec. 25, 2012**

(54) **LEVELING BLOCK WHEEL CHOCK**

(75) Inventors: **David J. Rossman**, Greenville, SC (US);  
**Bruce A. Angel**, Stokesdale, NC (US)

(73) Assignee: **Camco Manufacturing, Inc.**,  
Greensboro, NC (US)

(\*\*) Term: **14 Years**

(21) Appl. No.: **29/421,600**

(22) Filed: **Aug. 20, 2012**

(51) **LOC (9) Cl.** ..... **12-06**

(52) **U.S. Cl.** ..... **D12/217**

(58) **Field of Classification Search** ..... D12/217,  
D12/203, 400, 120, 180, 114; 14/69.5, 71.5;  
280/293, 507; 267/139-140; 410/30, 49,  
410/9; 211/20; 188/5, 32, 36, 4 R; 186/32,  
186/52; 248/346, 352, 221.12, 222.41, 222.51  
See application file for complete search history.

(56) **References Cited**

**U.S. PATENT DOCUMENTS**

D316,243 S *	4/1991	Henry	.....	D12/217
D326,254 S *	5/1992	Ziaylek et al.	.....	D12/217
D365,078 S *	12/1995	Ziaylek	.....	D12/217
D474,729 S *	5/2003	Sargent	.....	D12/217
D493,408 S	7/2004	Chrisco et al.		
7,040,461 B2	5/2006	Chrisco et al.		
D524,222 S *	7/2006	Chrisco et al.	.....	D12/217
D577,651 S	9/2008	Shaw		
D594,398 S *	6/2009	Tai	.....	D12/217
D601,479 S	10/2009	Shaw		
D646,614 S	10/2011	Brockington et al.		
D656,882 S *	4/2012	Beranek et al.	.....	D12/217
D662,026 S *	6/2012	Beranek et al.	.....	D12/217

**OTHER PUBLICATIONS**

Ref. No. 1, A: Wheel Chock, Trailer Aid Catalog Spring/Summer 2006, p. 16, Aug. 15, 2012, 1 Page.

Ref. No. 2, F: Super Wheel Chock, Camco RV Catalog 2007, p. 69, Aug. 15, 2012, 1 Page.

Ref. No. 3, Valterra A10-0908 Red Wheel Chock, website (www.amazon.com) Aug. 15, 2012, 1 Page.

Ref. No. 4, Buyers Rubber Wheel Chock, website (www.amazon.com) Aug. 15, 2012, 1 Page.

Ref. No. 5, Tri-Lynx 00018 Lynx Stop 'N. Chock Interlocking Wheel Chock, website (www.amazon.com) Aug. 15, 2012, 1 Page.

\* cited by examiner

*Primary Examiner* — Stacia Cadmus

(57) **CLAIM**

The ornamental design for a leveling block wheel chock, as shown and described.

**DESCRIPTION**

FIG. 1 is a front, top right perspective view of a leveling block wheel chock according to the invention;

FIG. 2 is a right elevational view according to the invention; and,

FIG. 3 is a left elevational view according to the invention; and,

FIG. 4 is a front elevational view according to the invention; and,

FIG. 5 is a rear elevational view according to the invention; and,

FIG. 6 is a top plan view according to the invention; and,

FIG. 7 is a bottom plan view according to the invention; and,

FIG. 8 is a back, bottom left perspective view according to the invention.

**1 Claim, 6 Drawing Sheets**

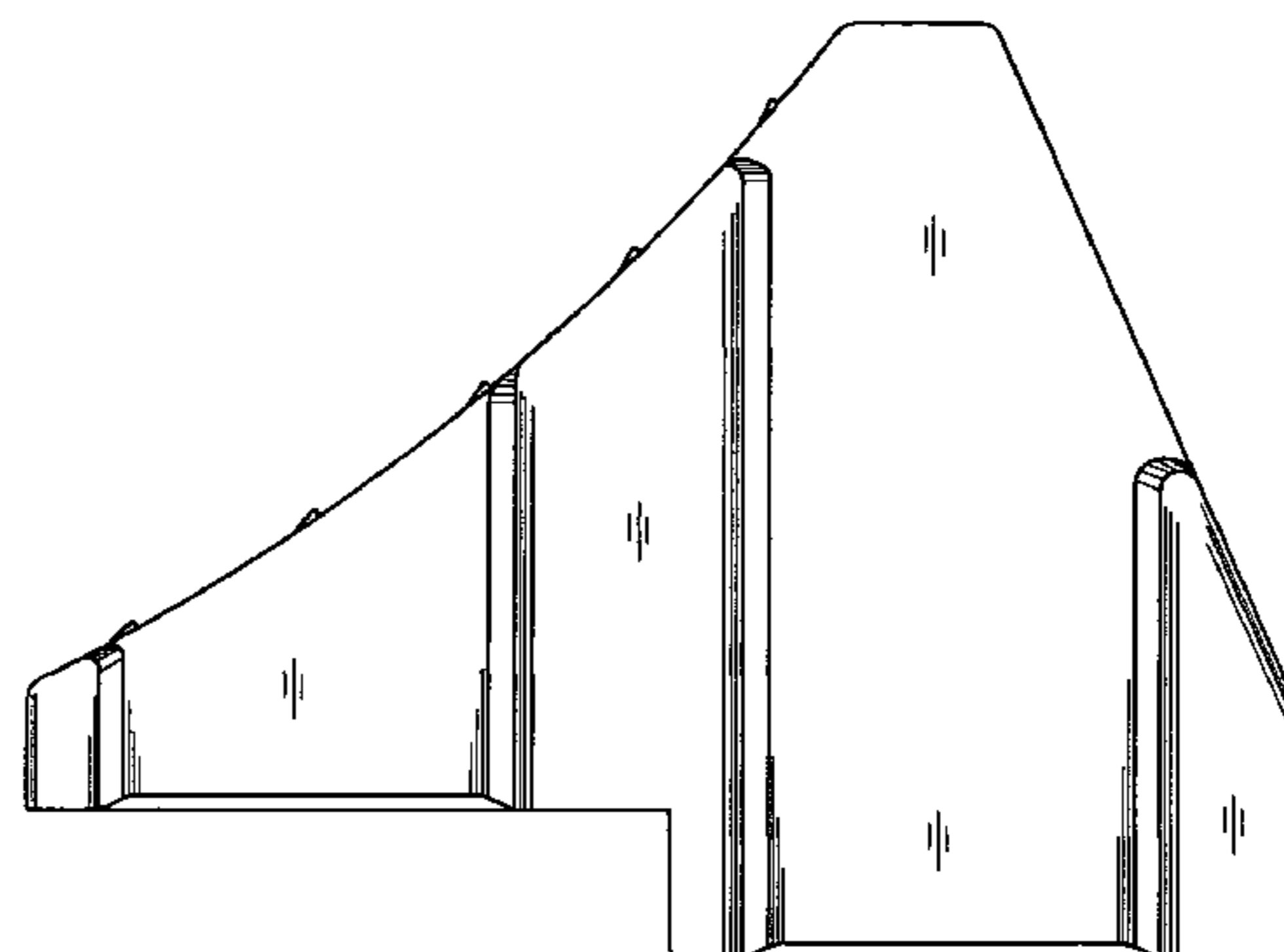
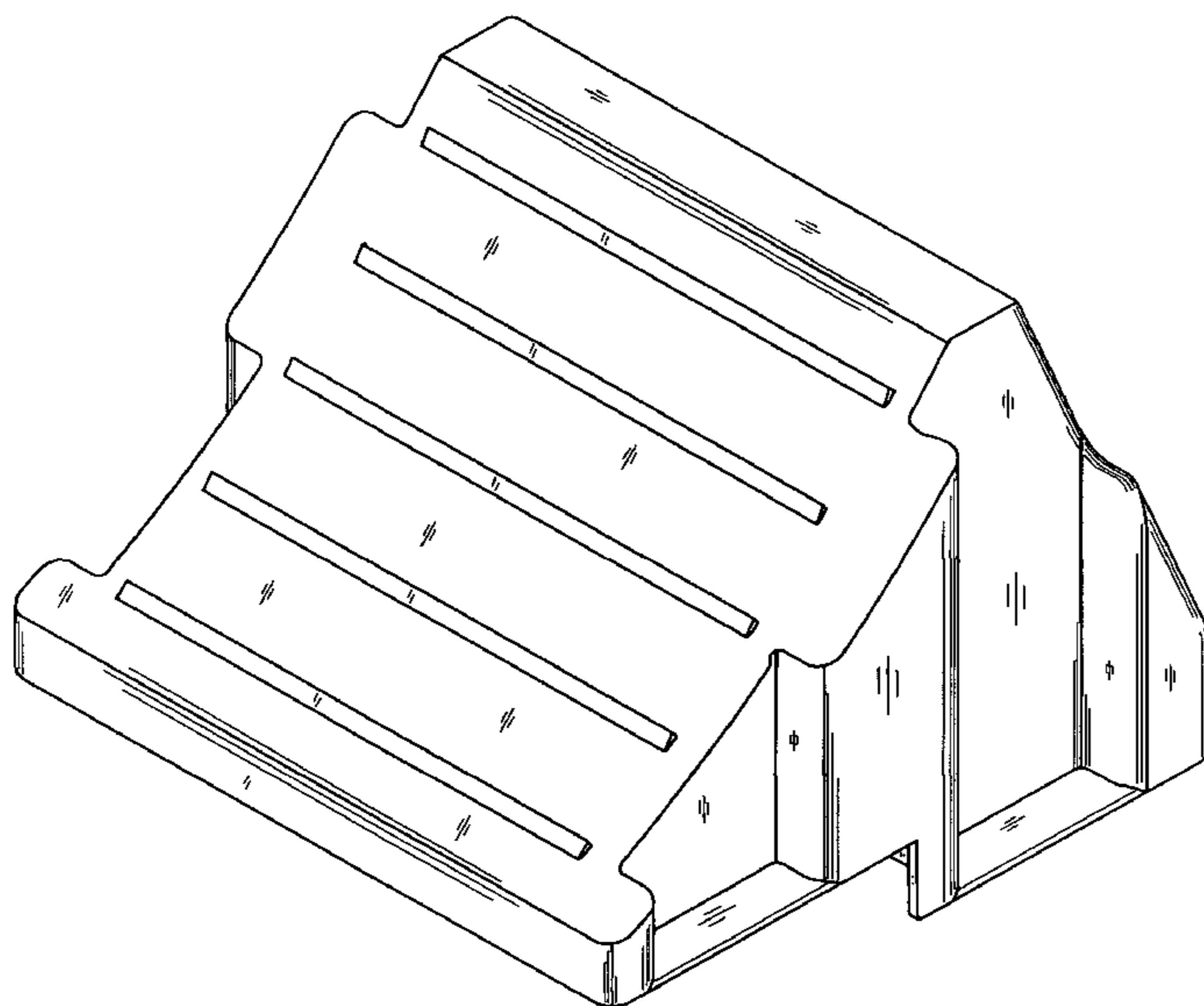

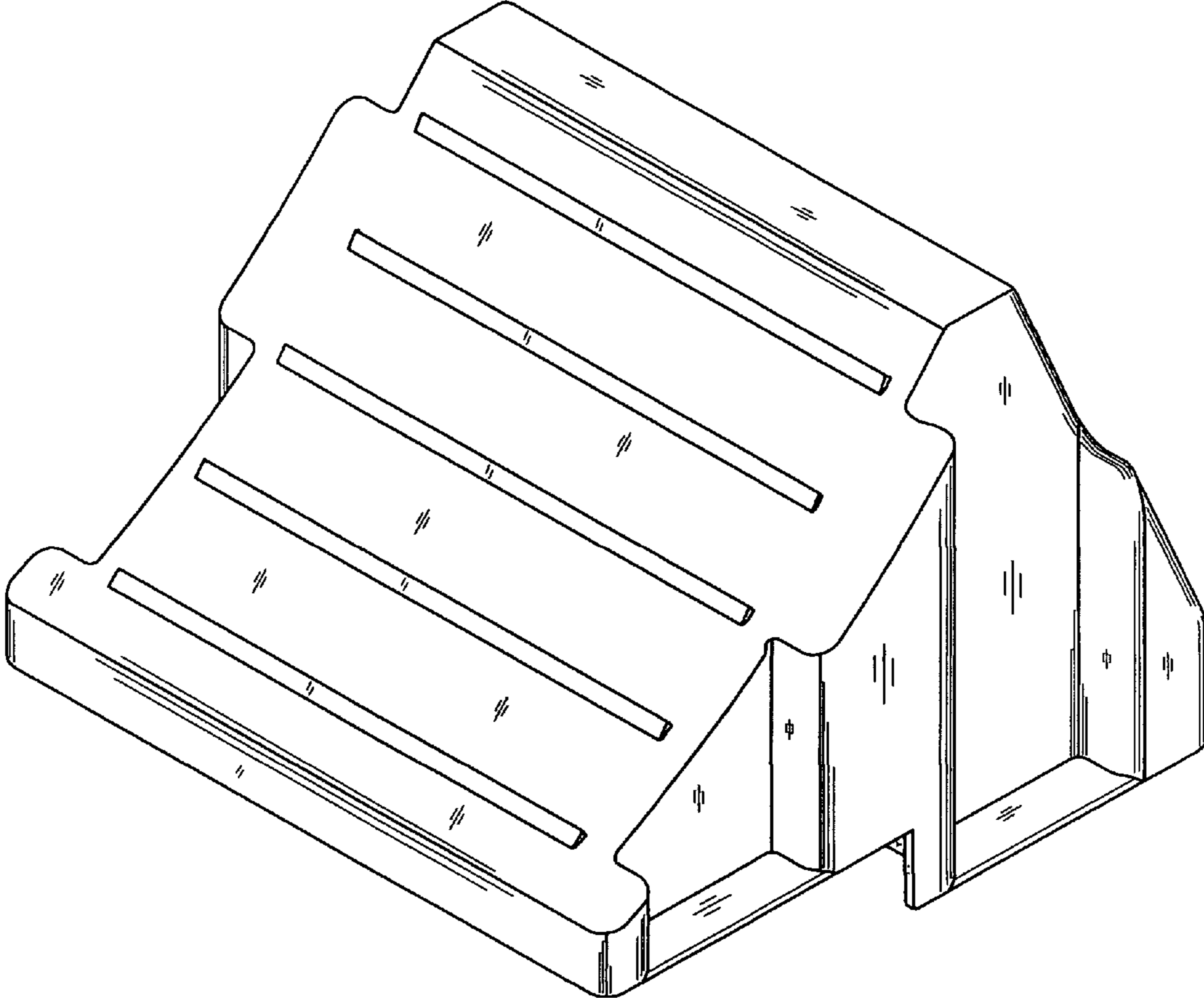

Fig. 1

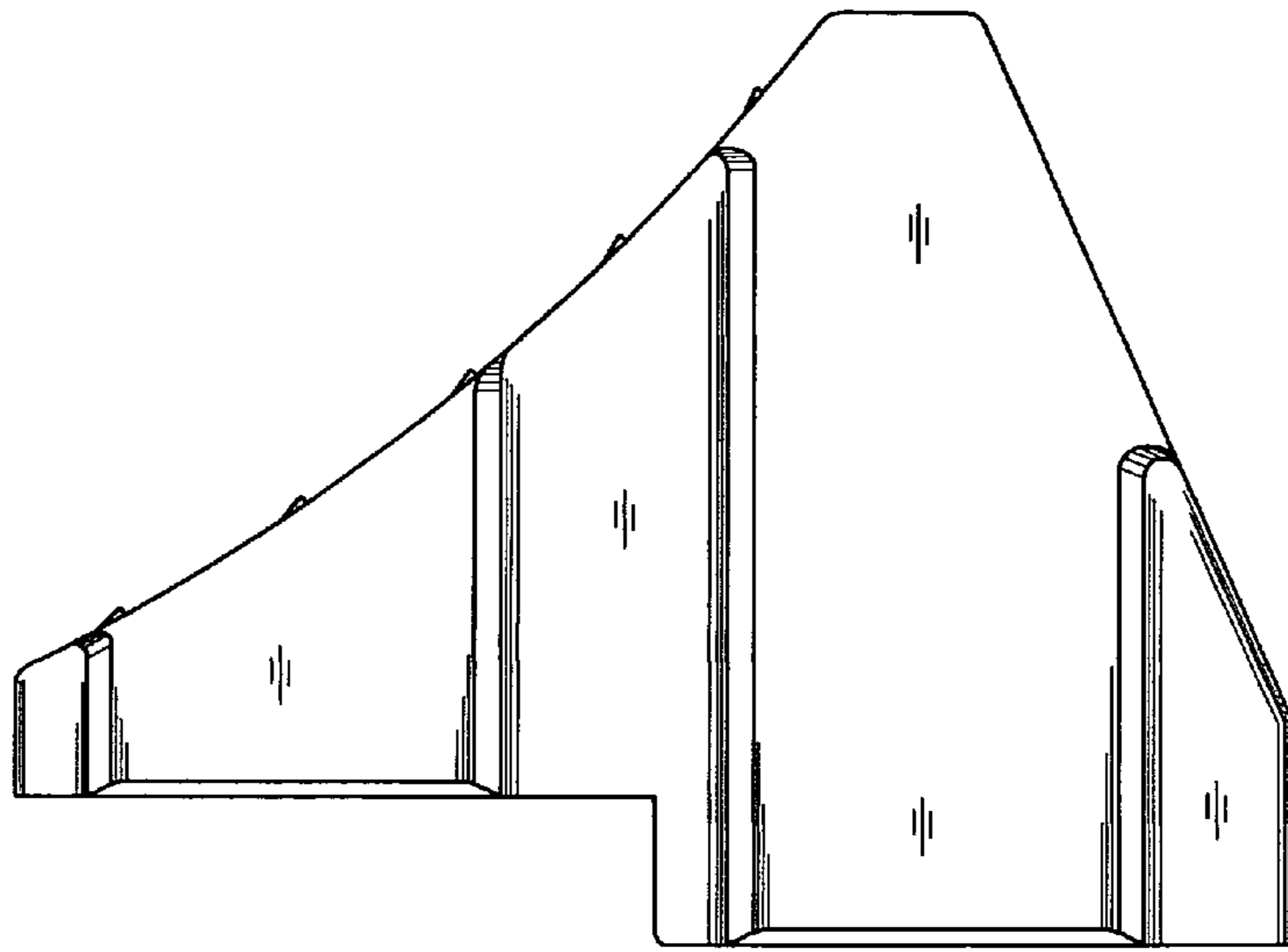

Fig. 2

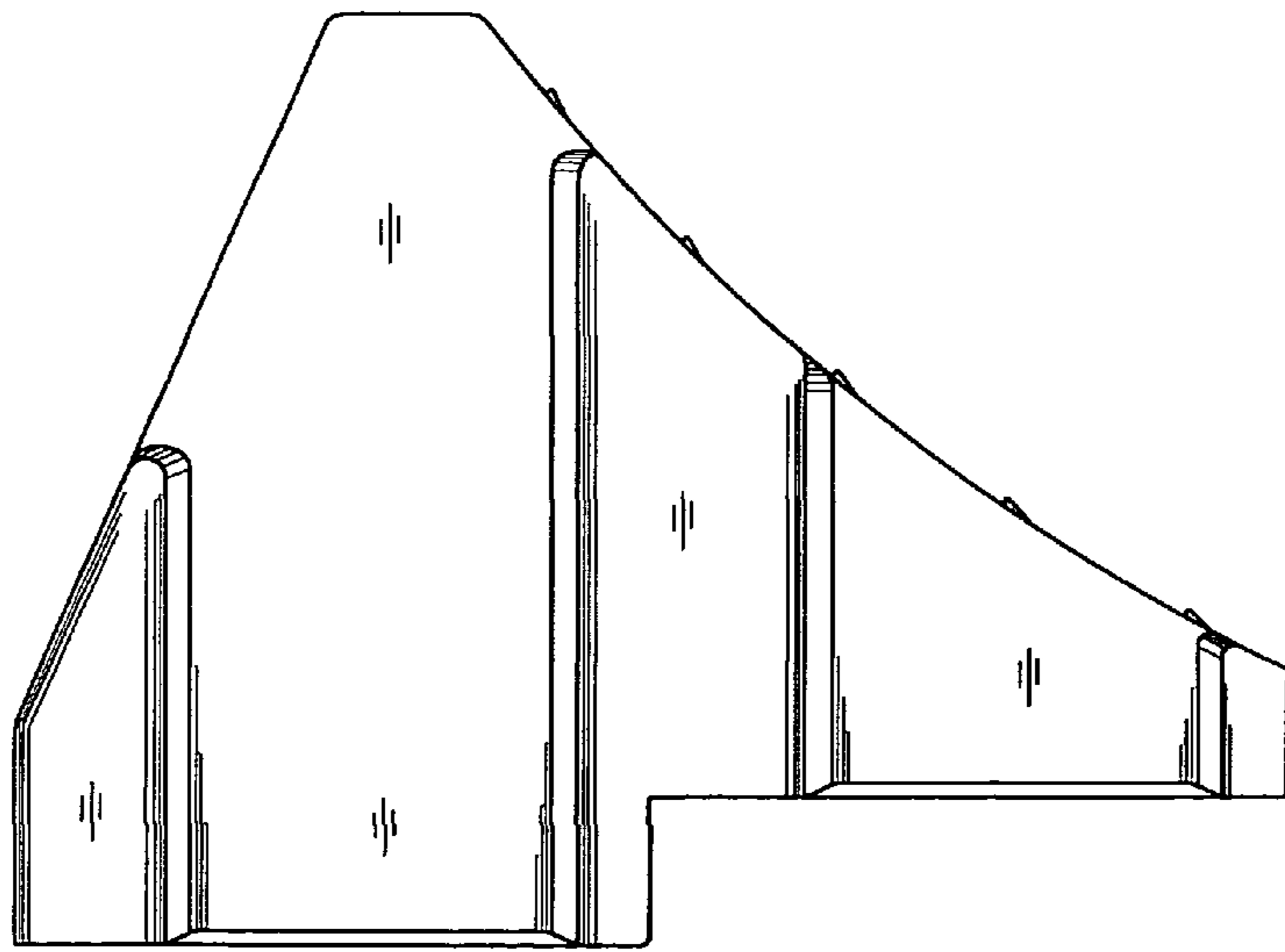

Fig. 3

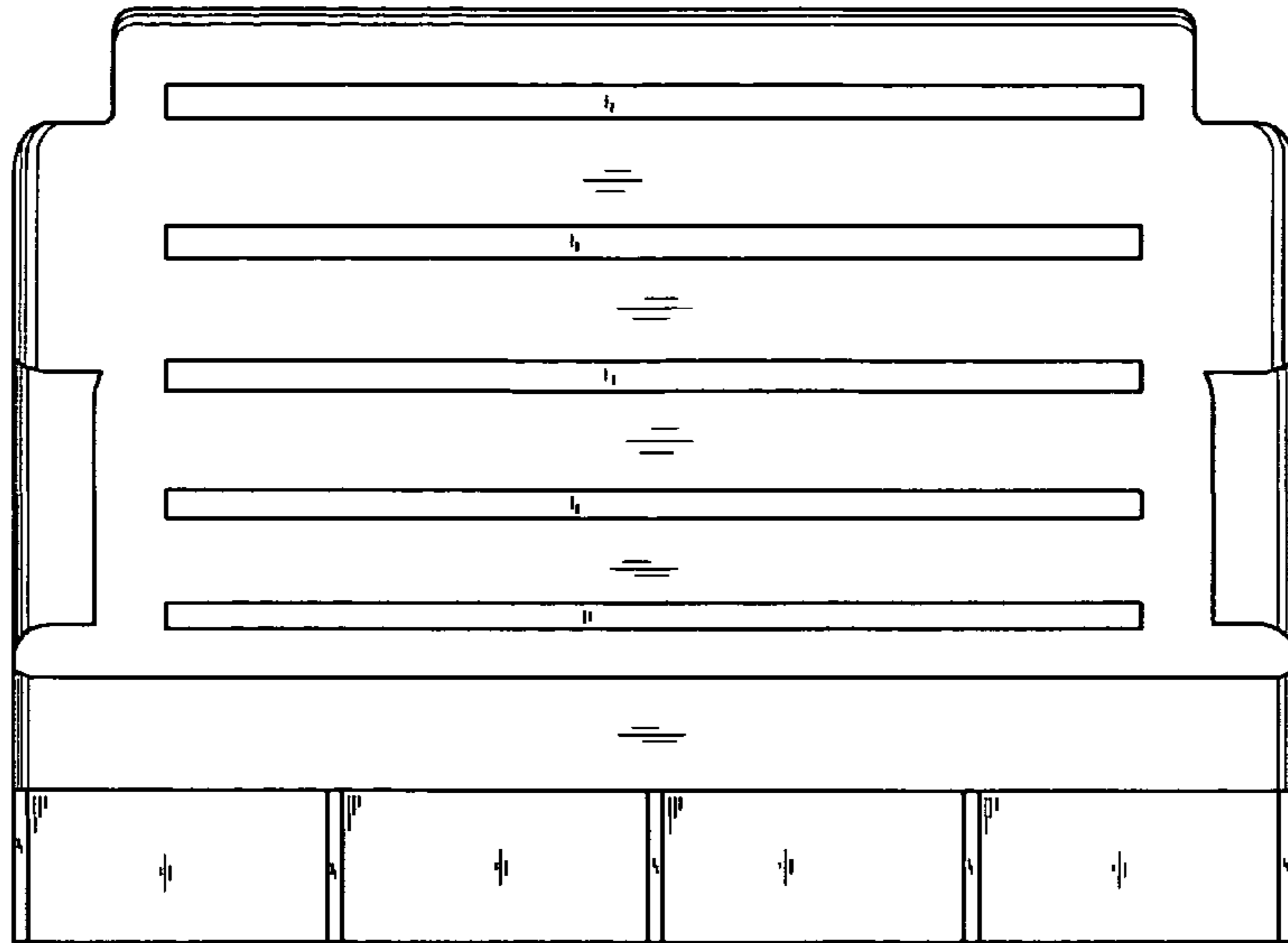

Fig. 4

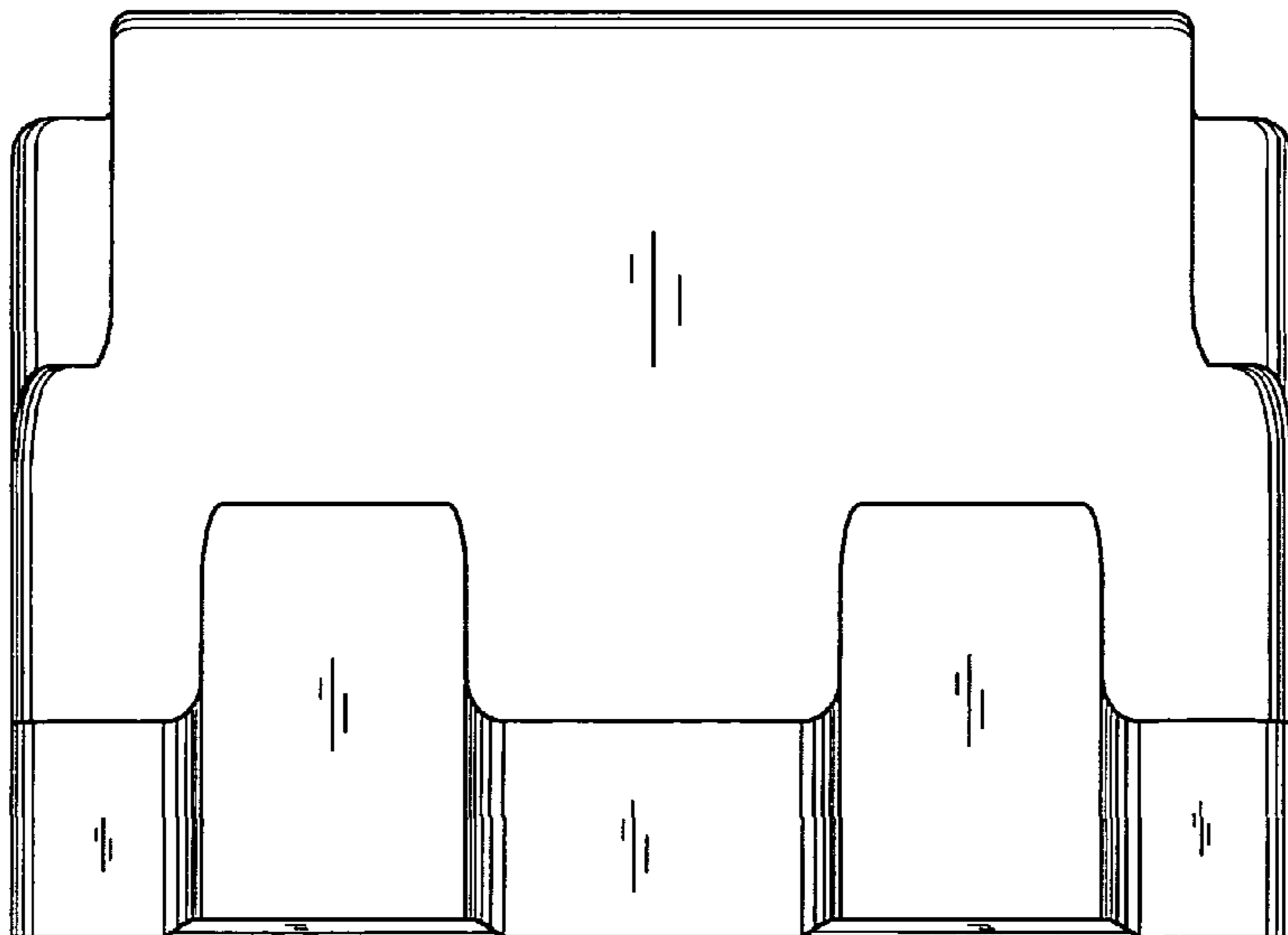

Fig. 5

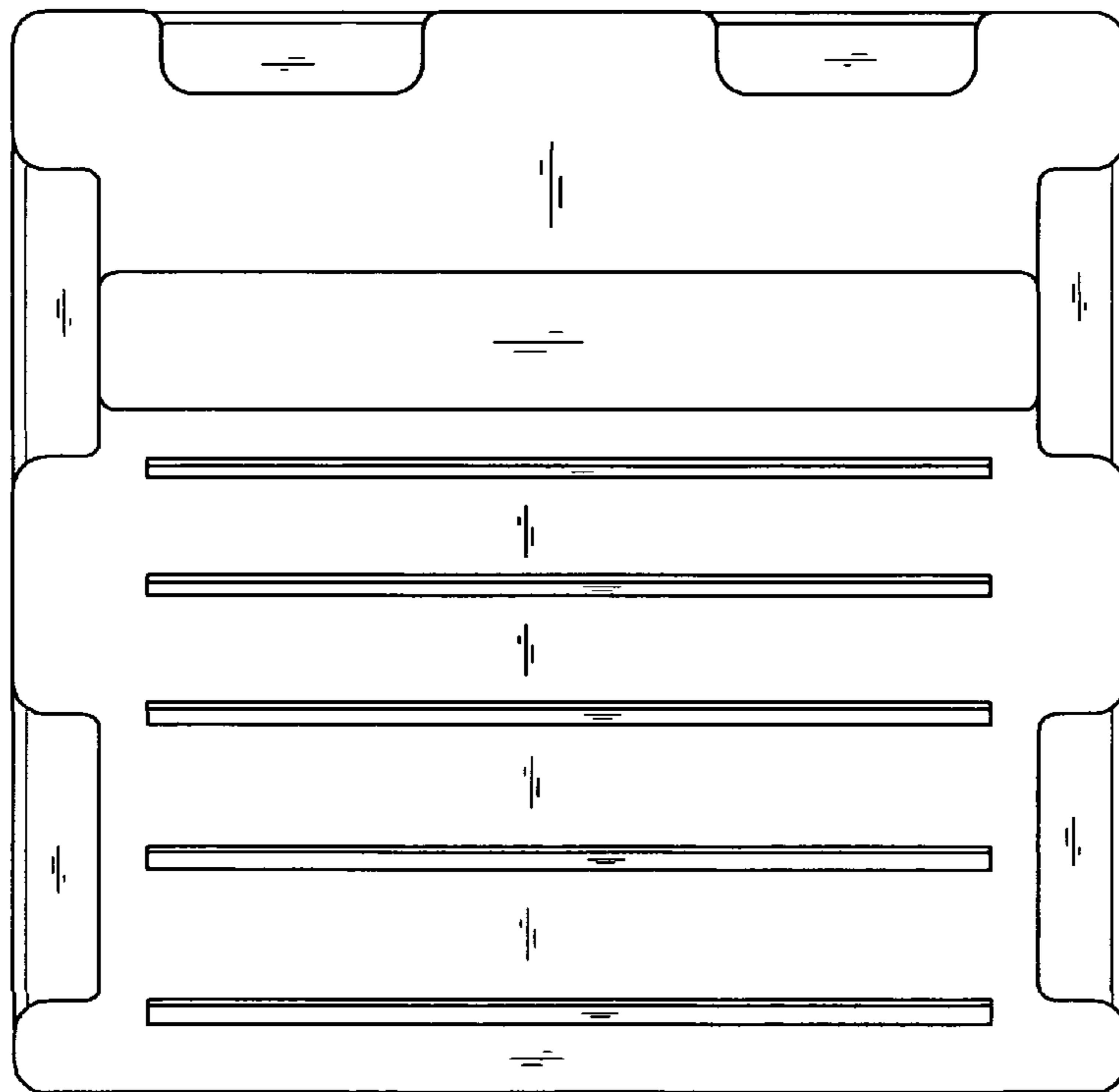

Fig. 6

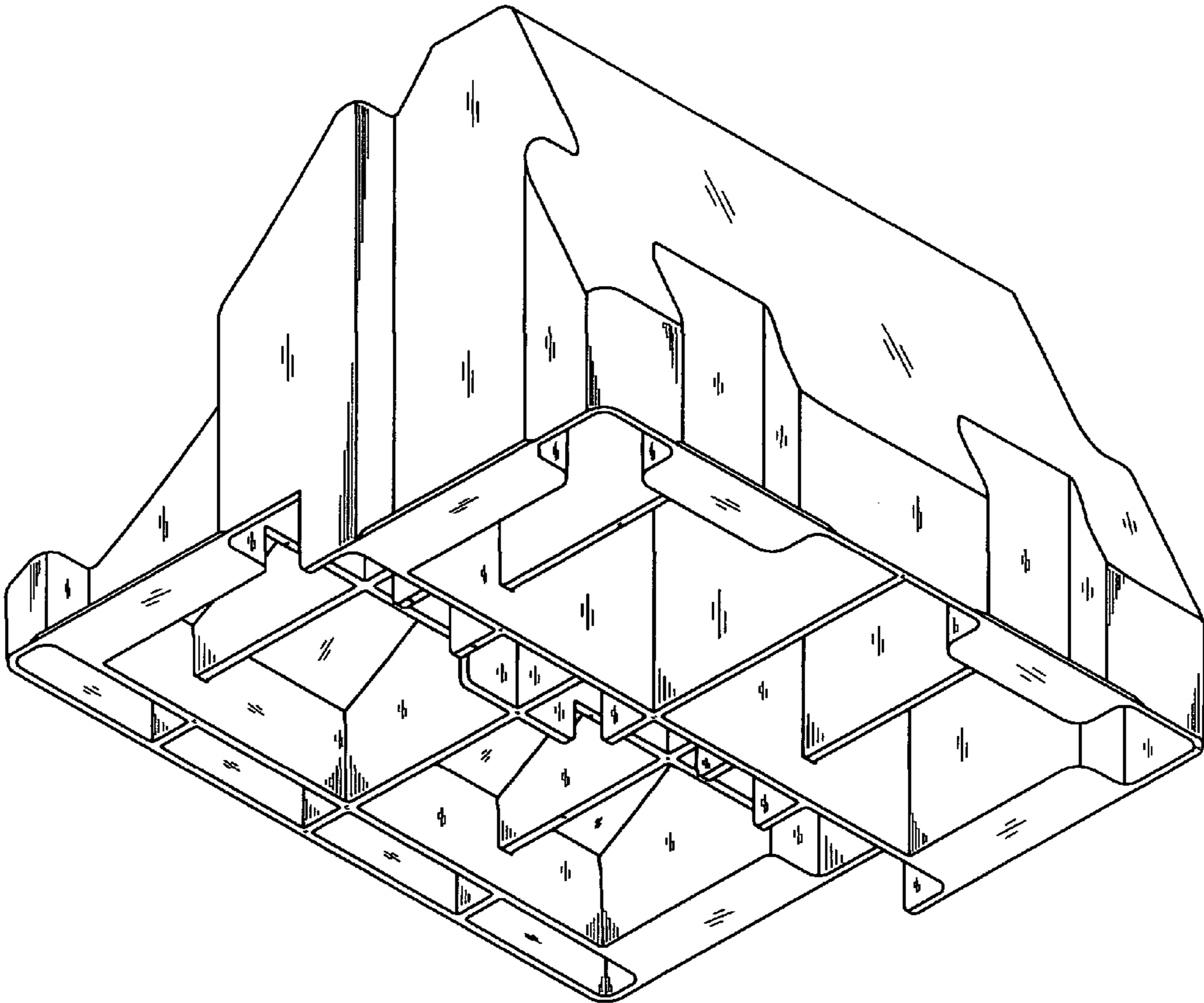

Fig. 7



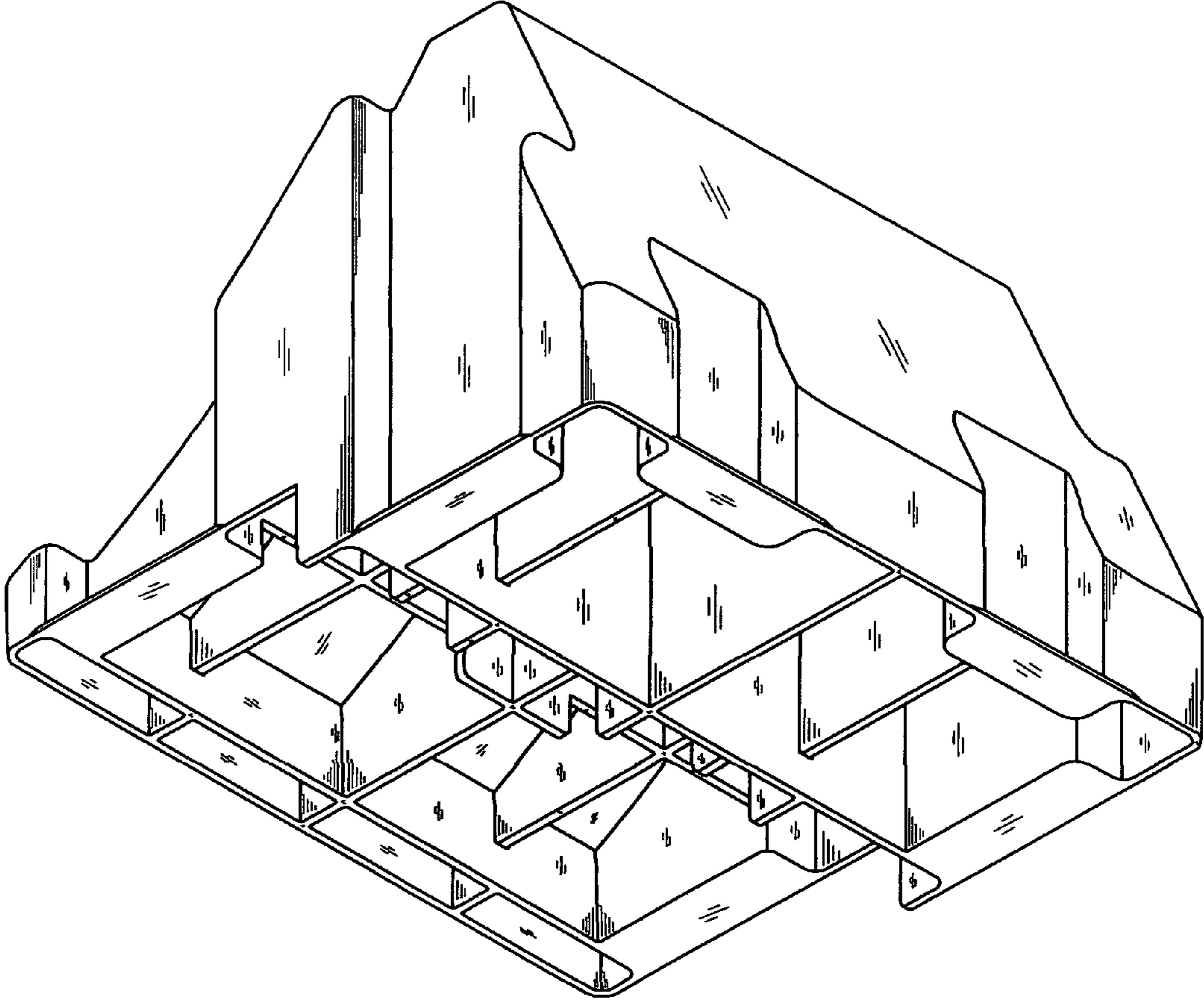

Fig. 8