

US00D672805S

(12) **United States Design Patent**
Peck

(10) **Patent No.:** **US D672,805 S**

(45) **Date of Patent:** **** Dec. 18, 2012**

(54) **PERCUSSION INSTRUMENT**

(75) Inventor: **David R. Peck**, Copley, OH (US)

(73) Assignee: **David R. Peck**, Copley, OH (US)

(**) Term: **14 Years**

(21) Appl. No.: **29/368,203**

(22) Filed: **Aug. 20, 2010**

(51) **LOC (9) Cl.** **17-04**

(52) **U.S. Cl.** **D17/22**

(58) **Field of Classification Search** D17/22,
D17/99; 84/DIG. 12, 723-733, 411 R, 412,
84/419-421, DIG. 3

See application file for complete search history.

(56) **References Cited**

U.S. PATENT DOCUMENTS

D174,401 S *	4/1955	Smirin	D17/22
D267,014 S *	11/1982	Migirian	D17/22
D297,945 S *	10/1988	Seiler	D17/22
D298,543 S *	11/1988	Benson et al.	D17/22
D321,528 S *	11/1991	Cohen et al.	D17/22
D348,895 S *	7/1994	Ito	D17/22
D413,618 S *	9/1999	Murwin	D17/22
D442,985 S *	5/2001	Liao	D17/22
D566,750 S *	4/2008	Monk	D17/22

* cited by examiner

Primary Examiner — Ian Simmons

Assistant Examiner — Carissa C Fitts

(74) *Attorney, Agent, or Firm* — Fay Sharpe LLP; Brian E. Turung

(57) **CLAIM**

The ornamental design for a percussion instrument, as shown and described.

DESCRIPTION

FIG. 1 is a front elevation view of a percussion instrument showing my new design;

FIG. 2 is a back elevation view of the percussion instrument showing my new design;

FIG. 3 is a top plan view of the percussion instrument showing my new design;

FIG. 4 is a side plan view of the percussion instrument showing my new design;

FIG. 5 is a back plan view of the percussion instrument showing my new design; and,

FIG. 6 is a front plan view of the percussion instrument showing my new design.

In the drawings, the broken lines depict environmental subject matter only and form no part of the claimed design.

1 Claim, 2 Drawing Sheets

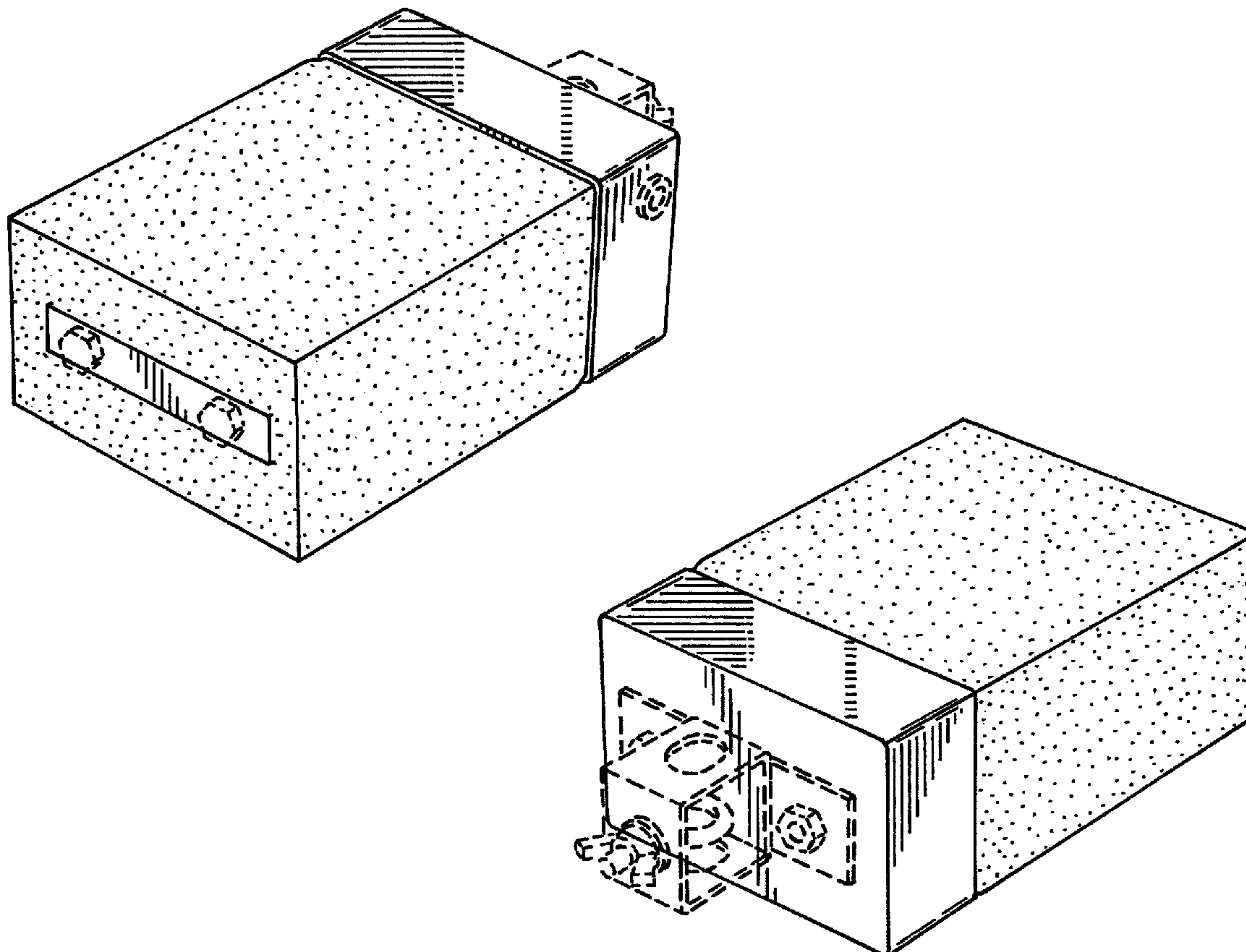

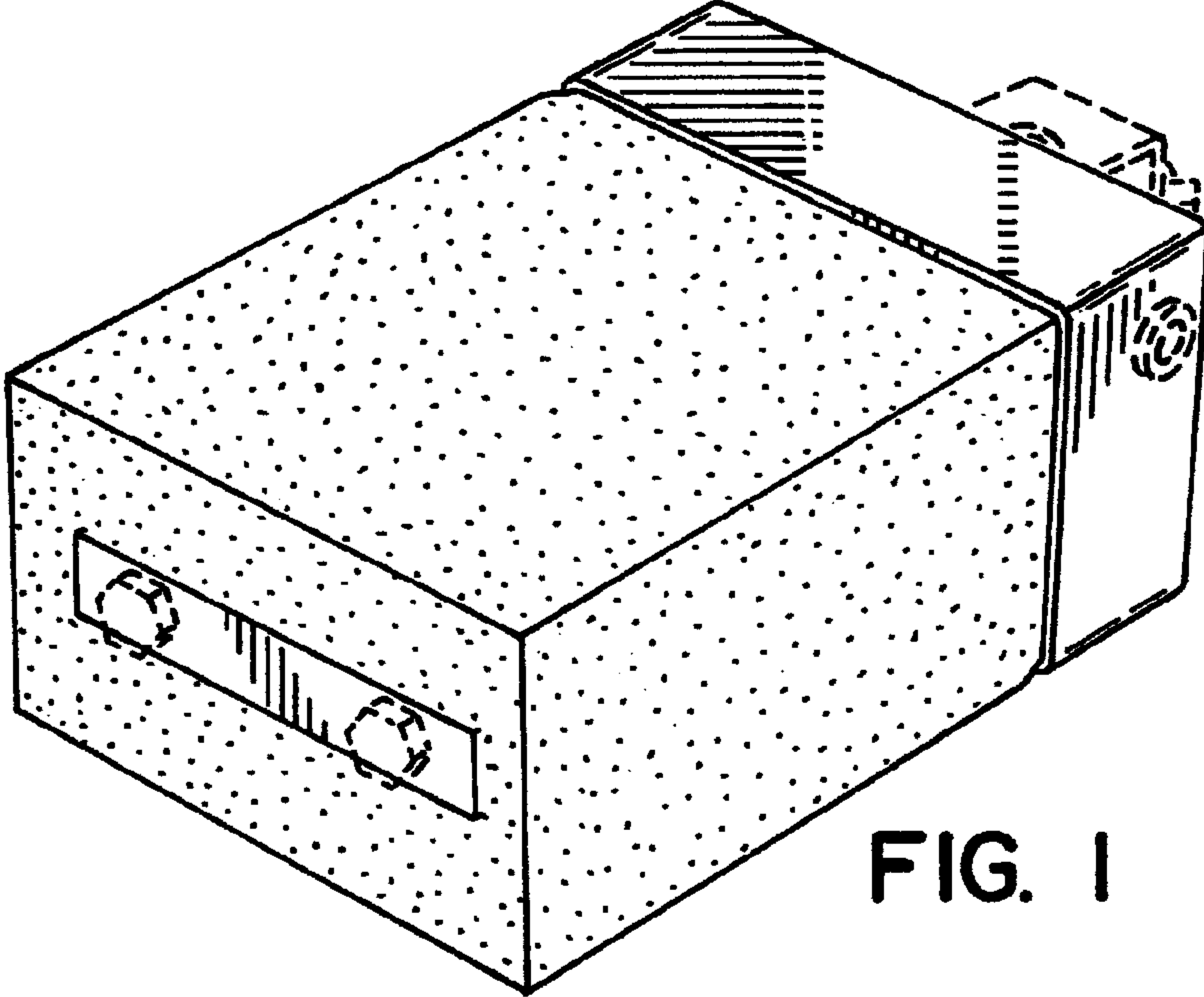

FIG. 1

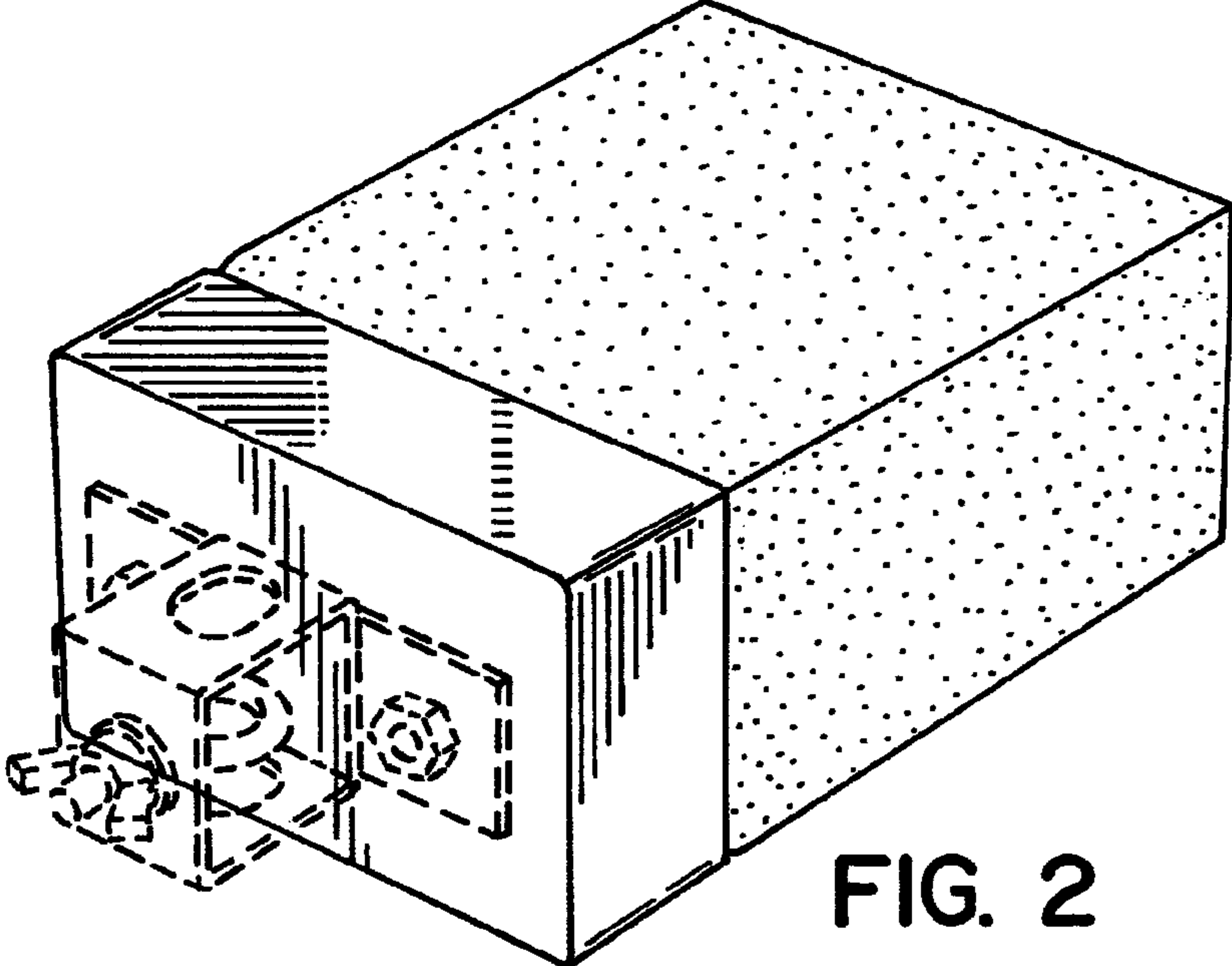

FIG. 2

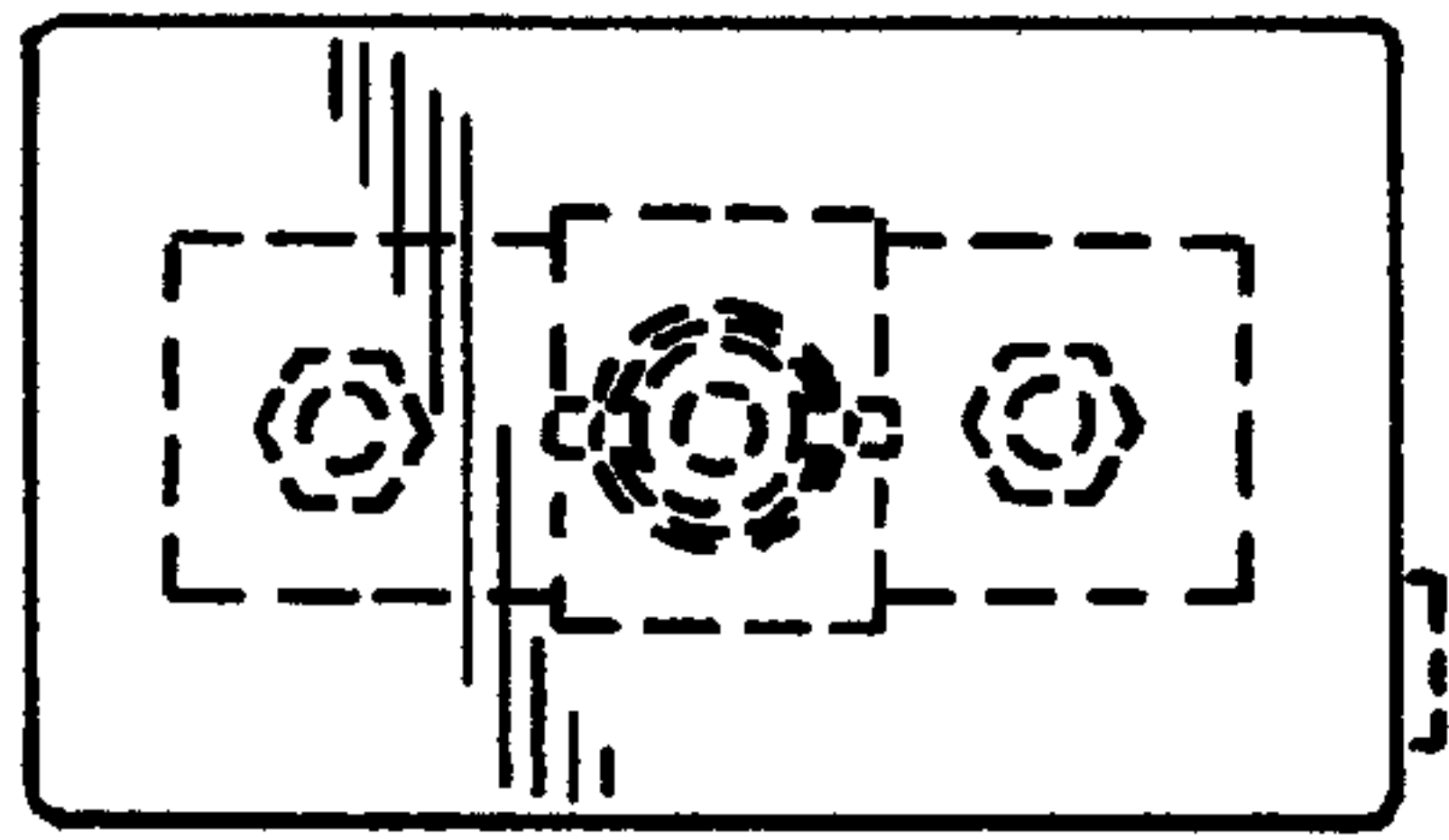

FIG. 5

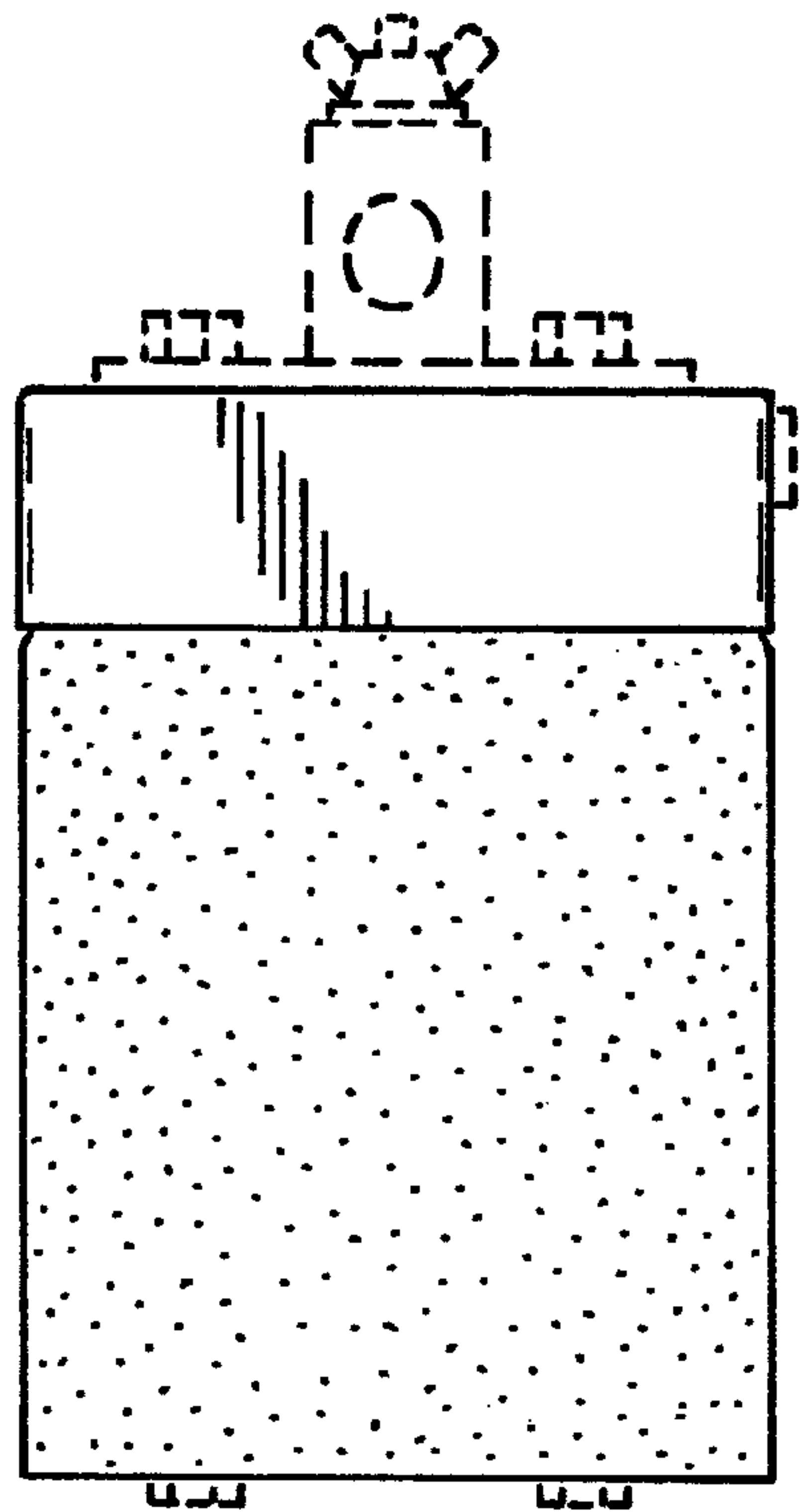

FIG. 3

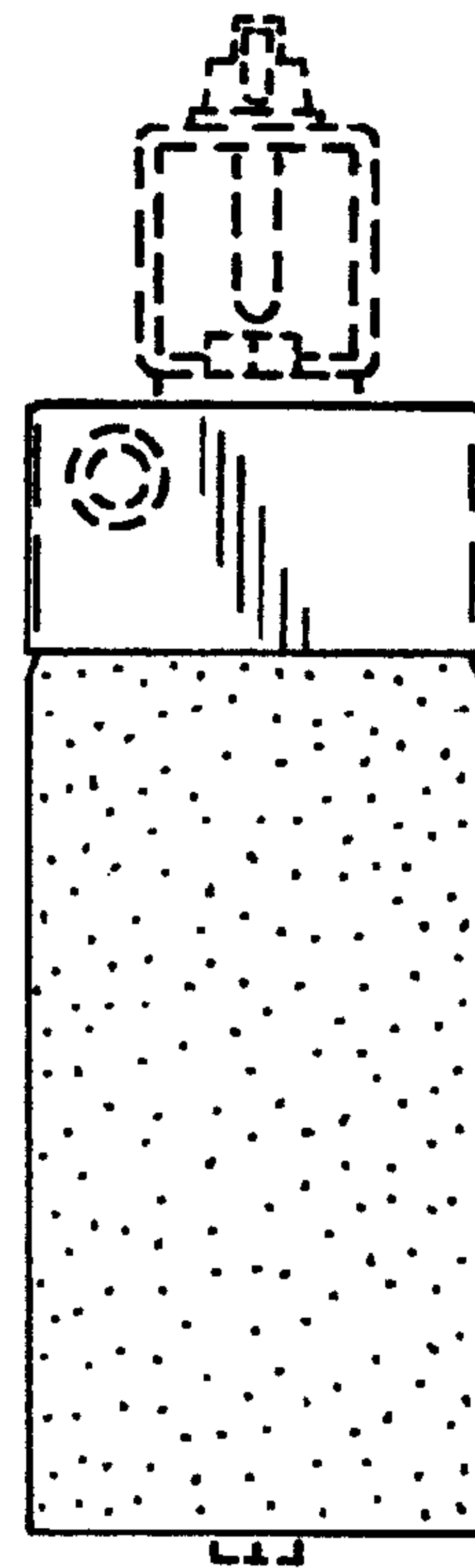

FIG. 4

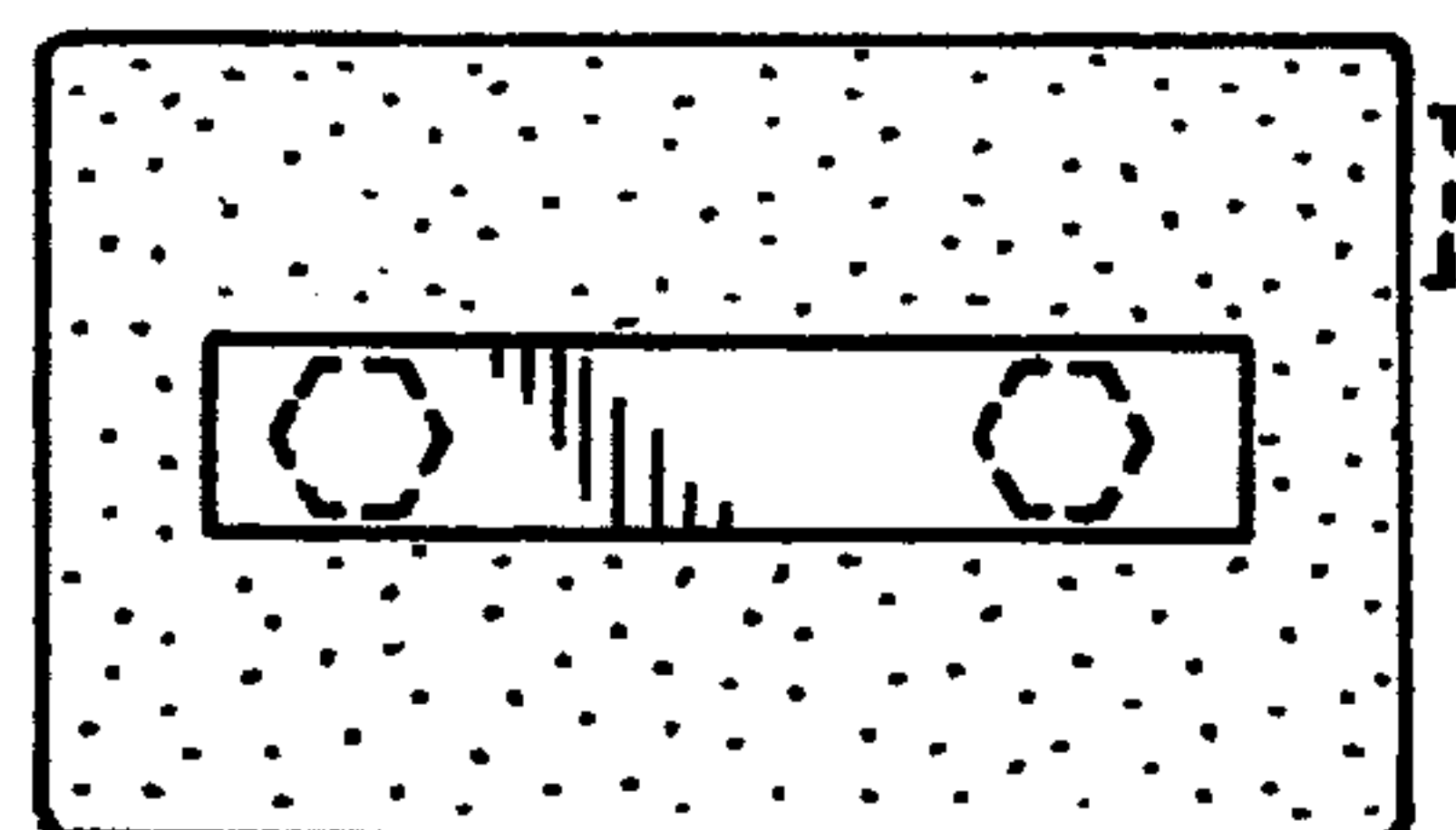

FIG. 6