



US00D672521S

(12) **United States Design Patent**
Cooper

(10) **Patent No.:** **US D672,521 S**

(45) **Date of Patent:** **** Dec. 11, 2012**

(54) **TRANSPORT DEVICE**

(76) **Inventor:** **Dale Cooper, American Falls, ID (US)**

(**) **Term:** **14 Years**

(21) **Appl. No.:** **29/415,817**

(22) **Filed:** **Mar. 14, 2012**

(51) **LOC (9) Cl.** **12-02**

(52) **U.S. Cl.** **D34/16**

(58) **Field of Classification Search** D34/12-26;
280/47.24, 47.26, 47.12, 47.18, 47.31, 641,
280/47.22, 47.131, 457.1; D15/17, 28, 27
See application file for complete search history.

(56) **References Cited**

U.S. PATENT DOCUMENTS

2,532,015	A *	11/1950	De Lay	280/47.23
2,973,884	A *	3/1961	West et al.	222/625
3,751,058	A *	8/1973	Larsen	280/30
3,774,930	A *	11/1973	Pravednekow	280/47.24
4,629,203	A *	12/1986	Ballard	280/47.26
D544,173	S *	6/2007	Mullen et al.	D34/16
D606,565	S *	12/2009	Hickenbottom	D15/28

* cited by examiner

Primary Examiner — Cynthia Ramirez

(74) *Attorney, Agent, or Firm* — Jones Waldo Holebrook & McDonough, PC

(57) **CLAIM**

The ornamental design for a transport device, as shown and described.

DESCRIPTION

FIG. 1 is a front perspective view of a transport device showing my new design.

FIG. 2 is a side view of the presently claimed design.

FIG. 3 is a side view opposite that shown in FIG. 2.

FIG. 4 is a front view of the presently claimed design.

FIG. 5 is a rear view of the presently claimed design.

FIG. 6 is a top view of the presently claimed design.

FIG. 7 is a bottom view of the presently claimed design.

FIG. 8 is a front perspective view of the presently claimed design showing the removable bucket detached from the frame.

FIG. 9 is a front perspective view of the presently claimed design showing the removable bucket detached from the frame and fitted with a lid; and,

FIG. 10 is a front perspective view of the lid shown in FIG. 9. The lid and the transport device are being shown separated for convenience of illustration. The bottom of the lid is not part of the claimed design.

The broken lines shown in the figures are included for the purpose of illustrating elements of the transport device and form no part of the claimed design.

1 Claim, 7 Drawing Sheets

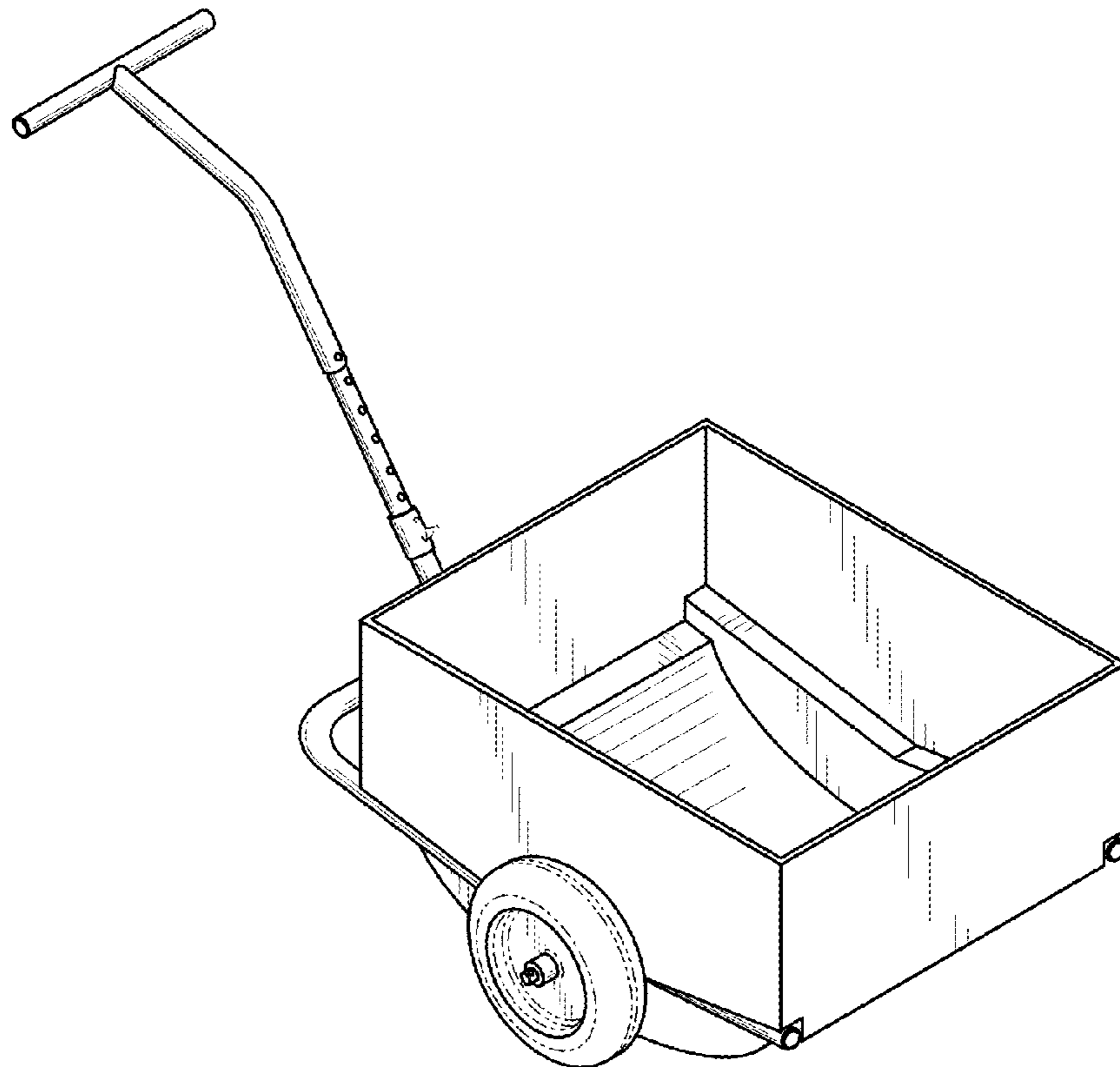

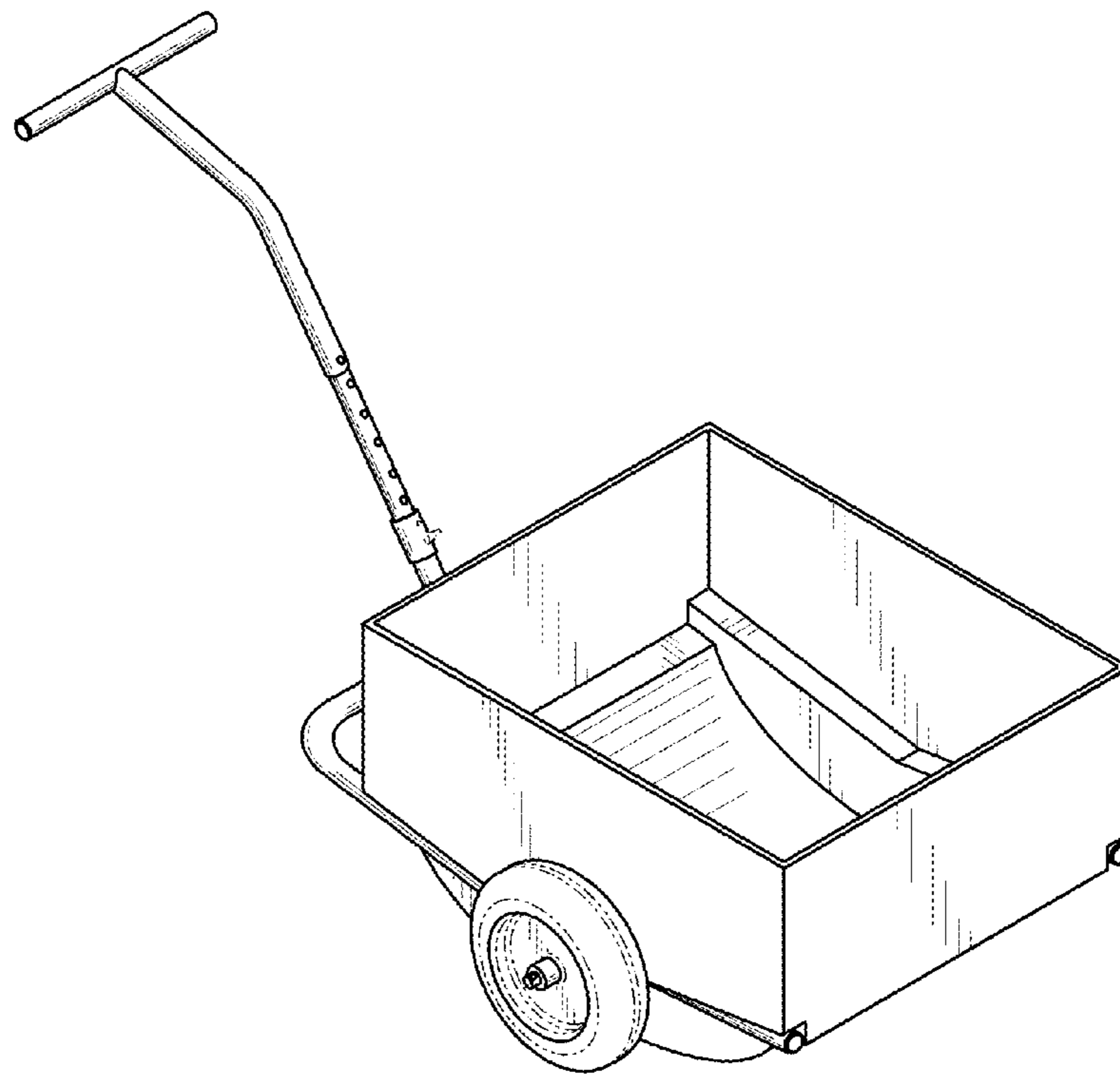

FIG. 1

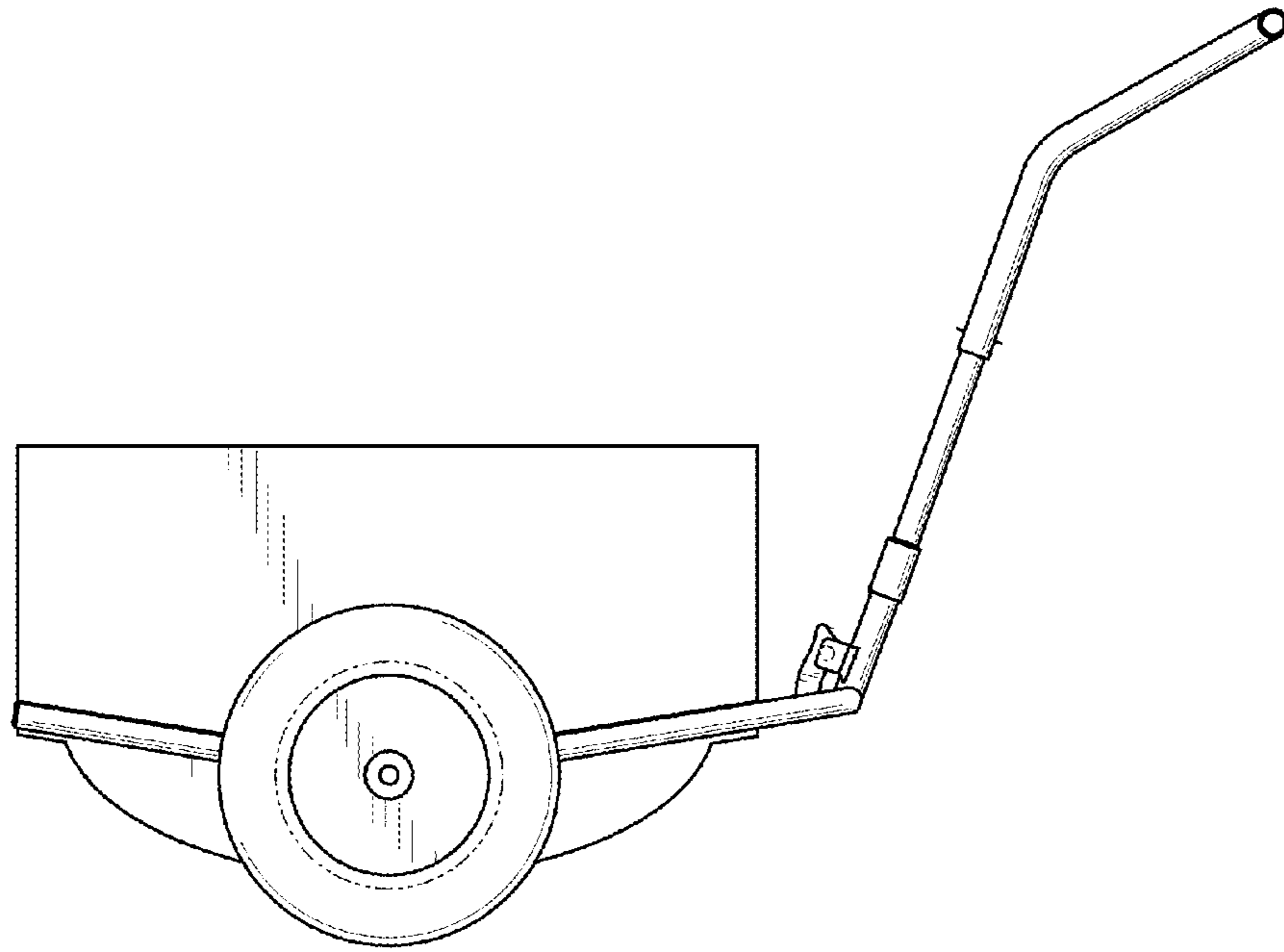

FIG. 2

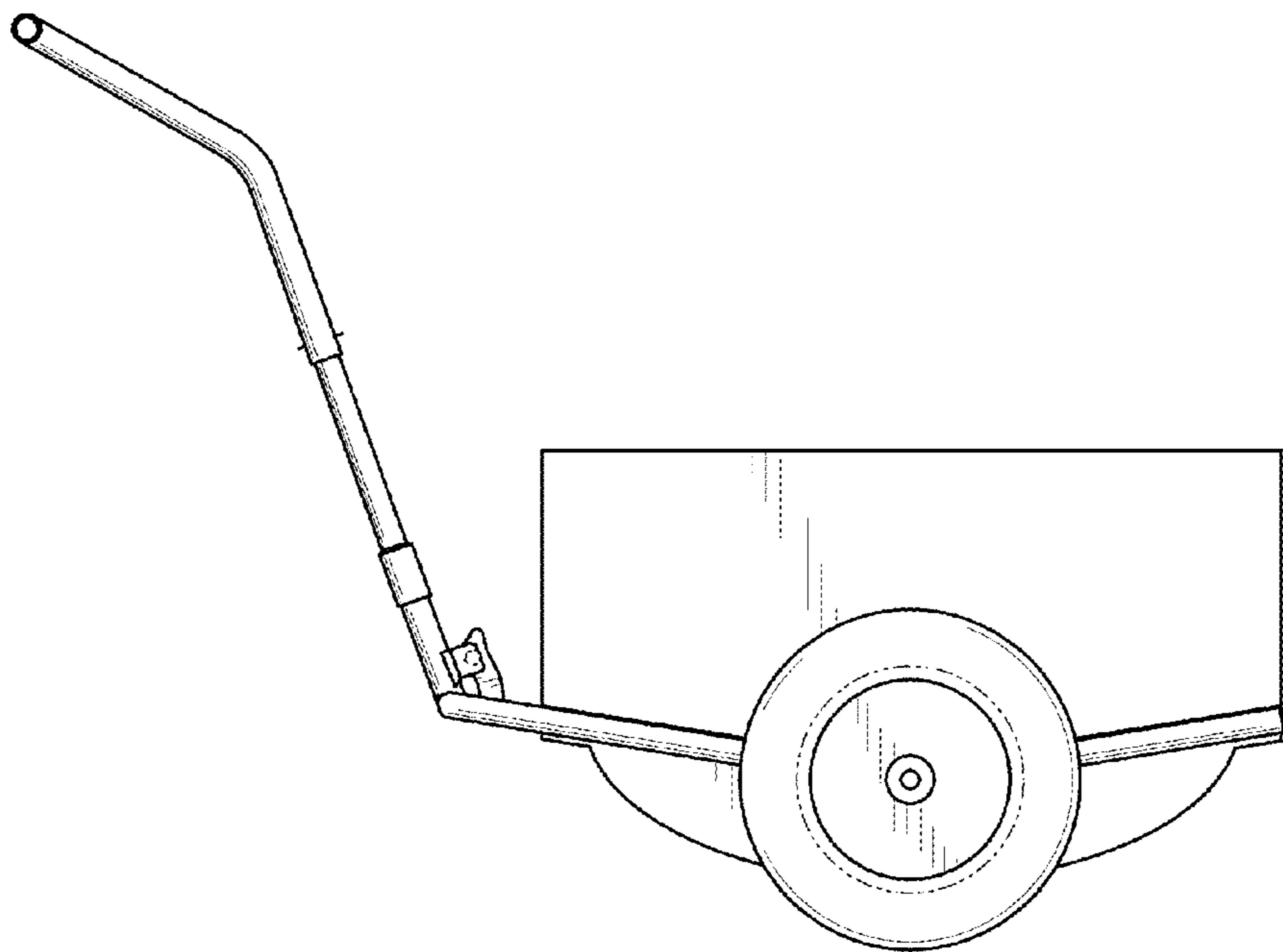

FIG. 3

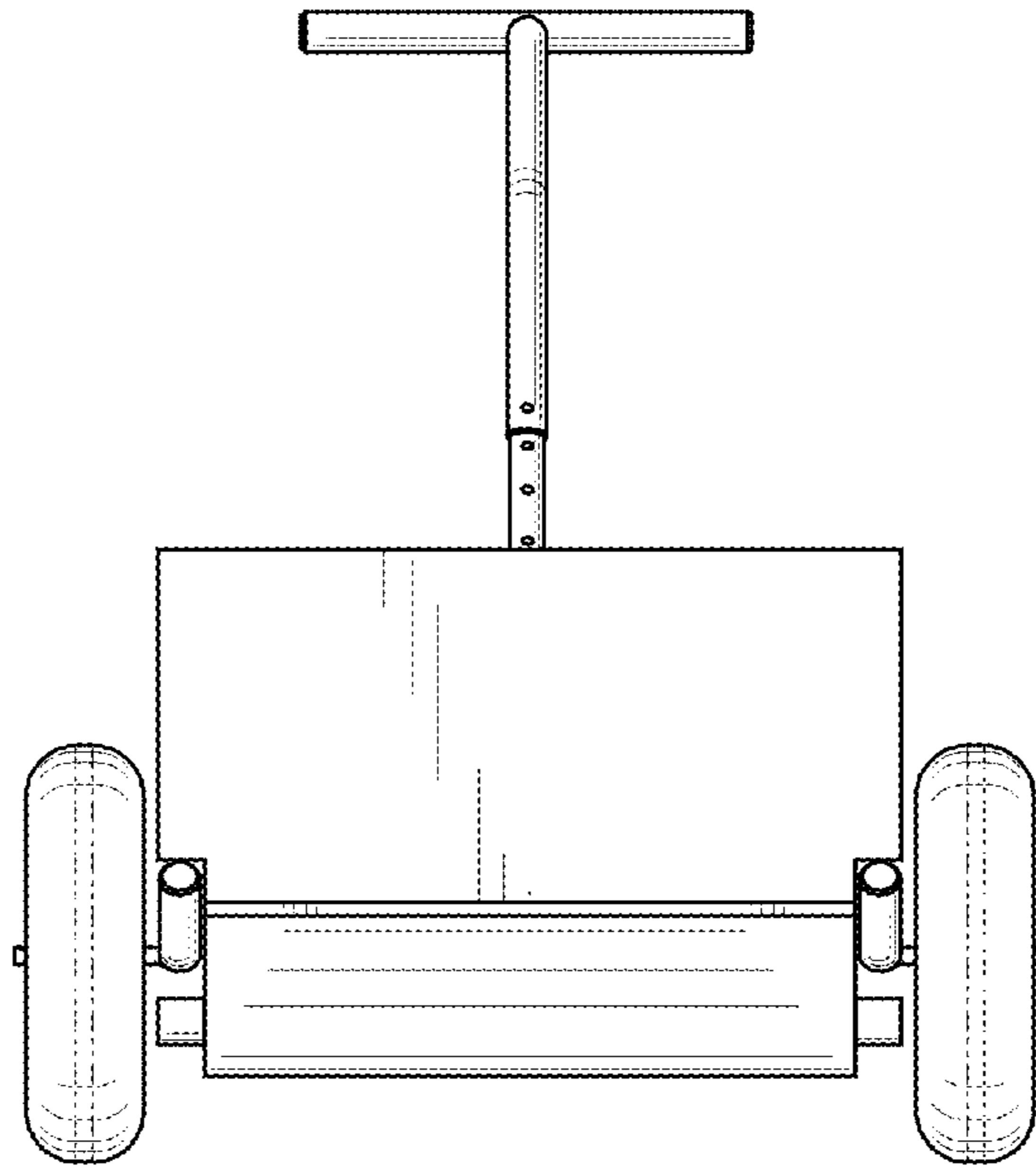

FIG. 4

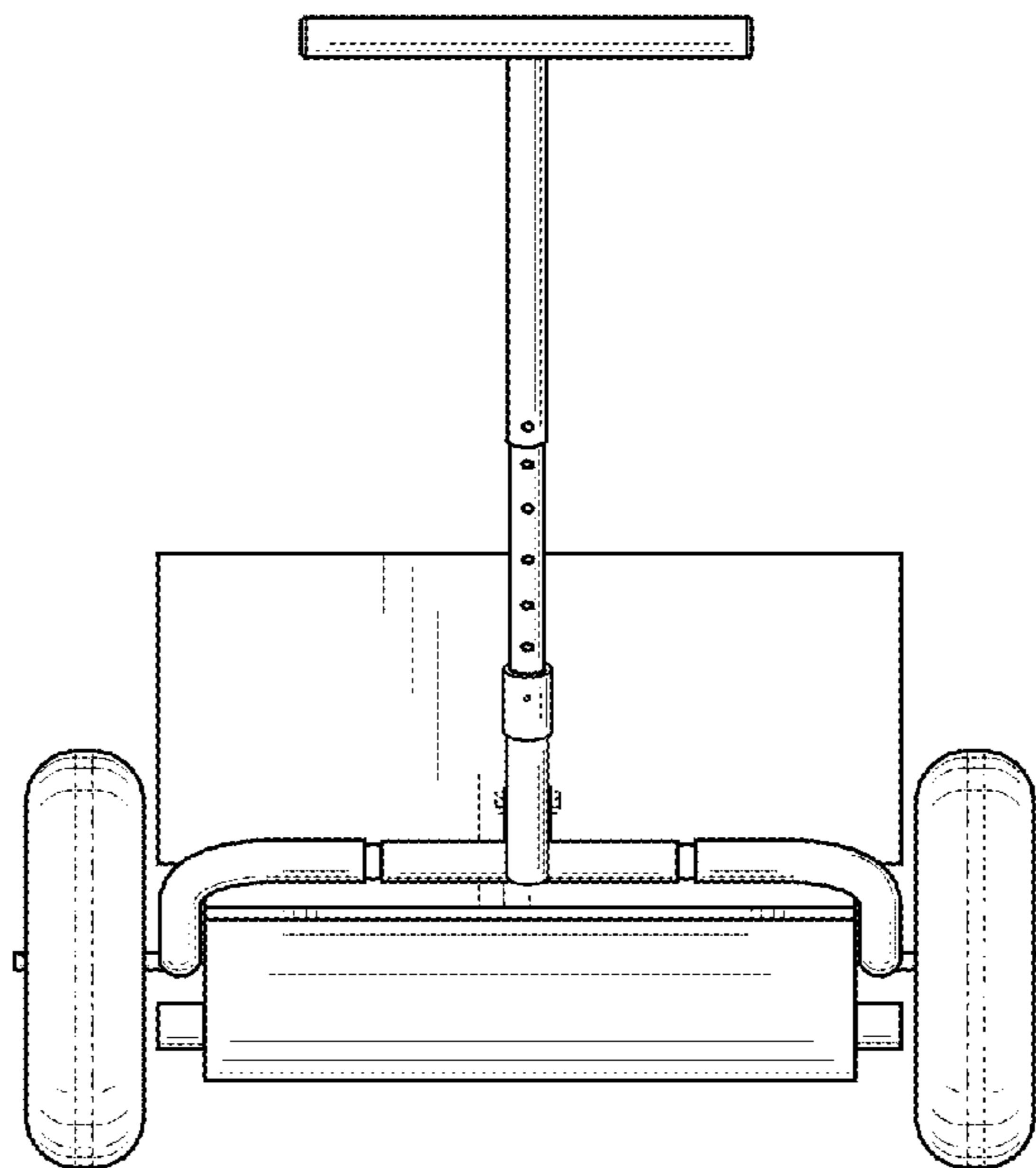

FIG. 5

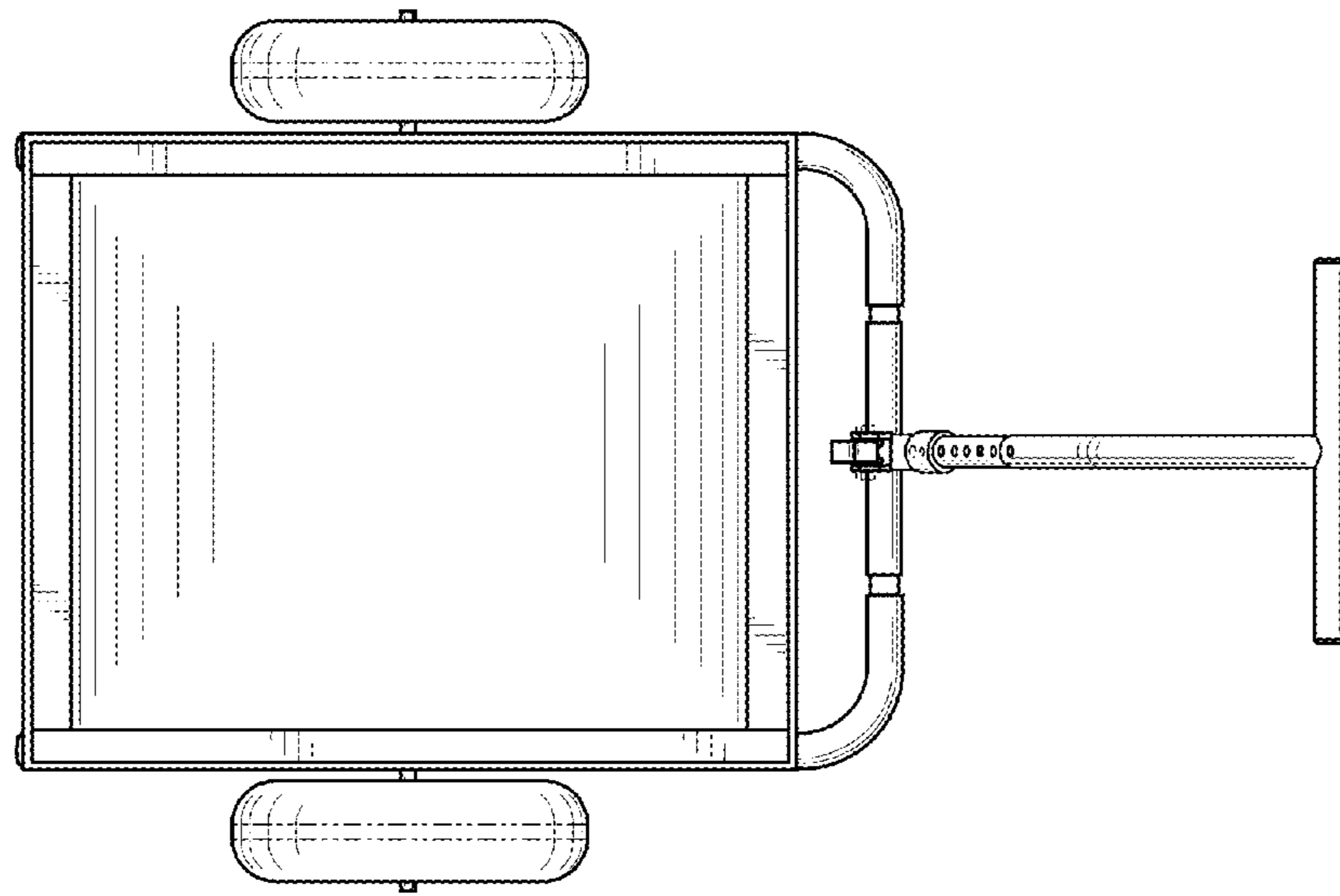

FIG. 6

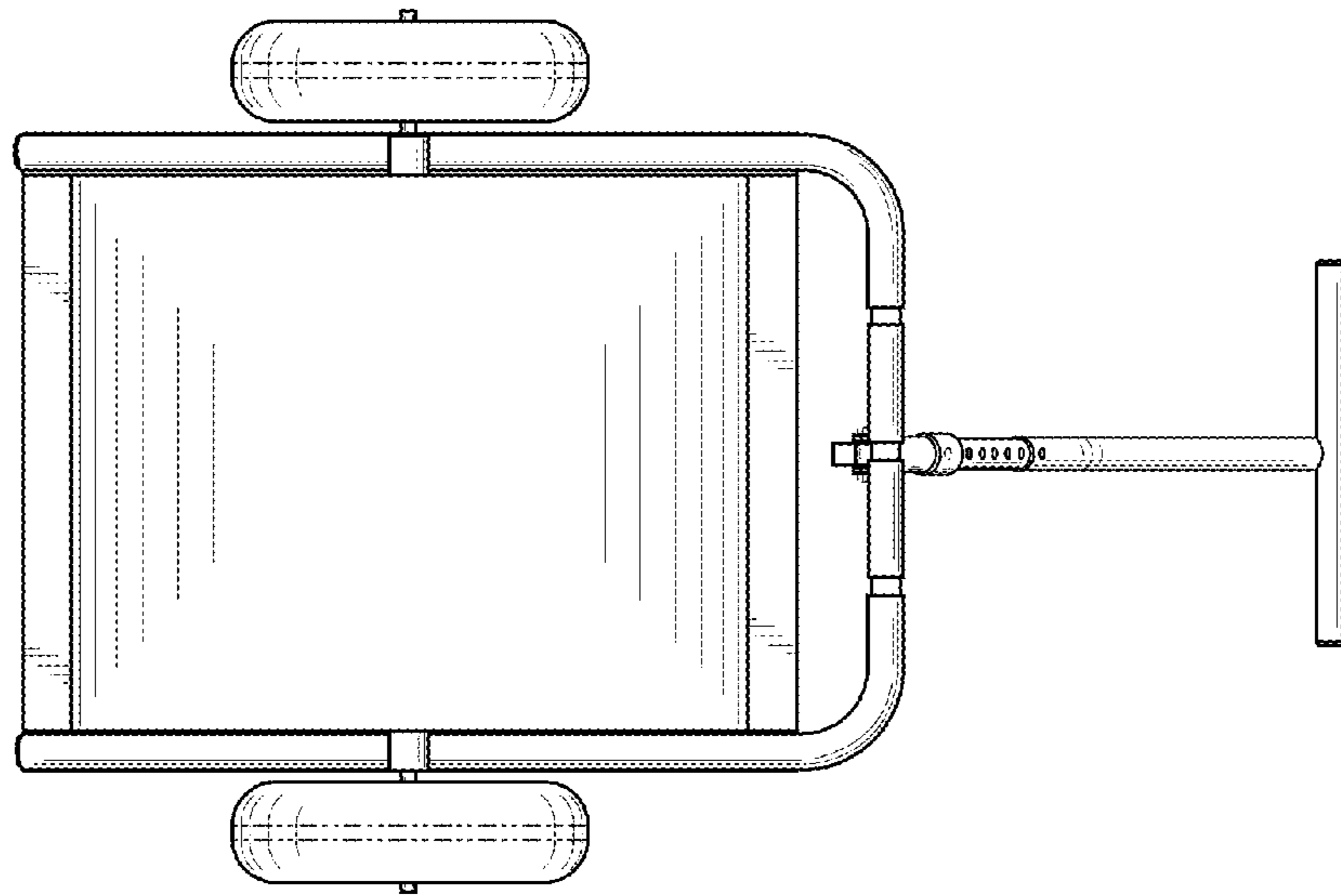

FIG. 7

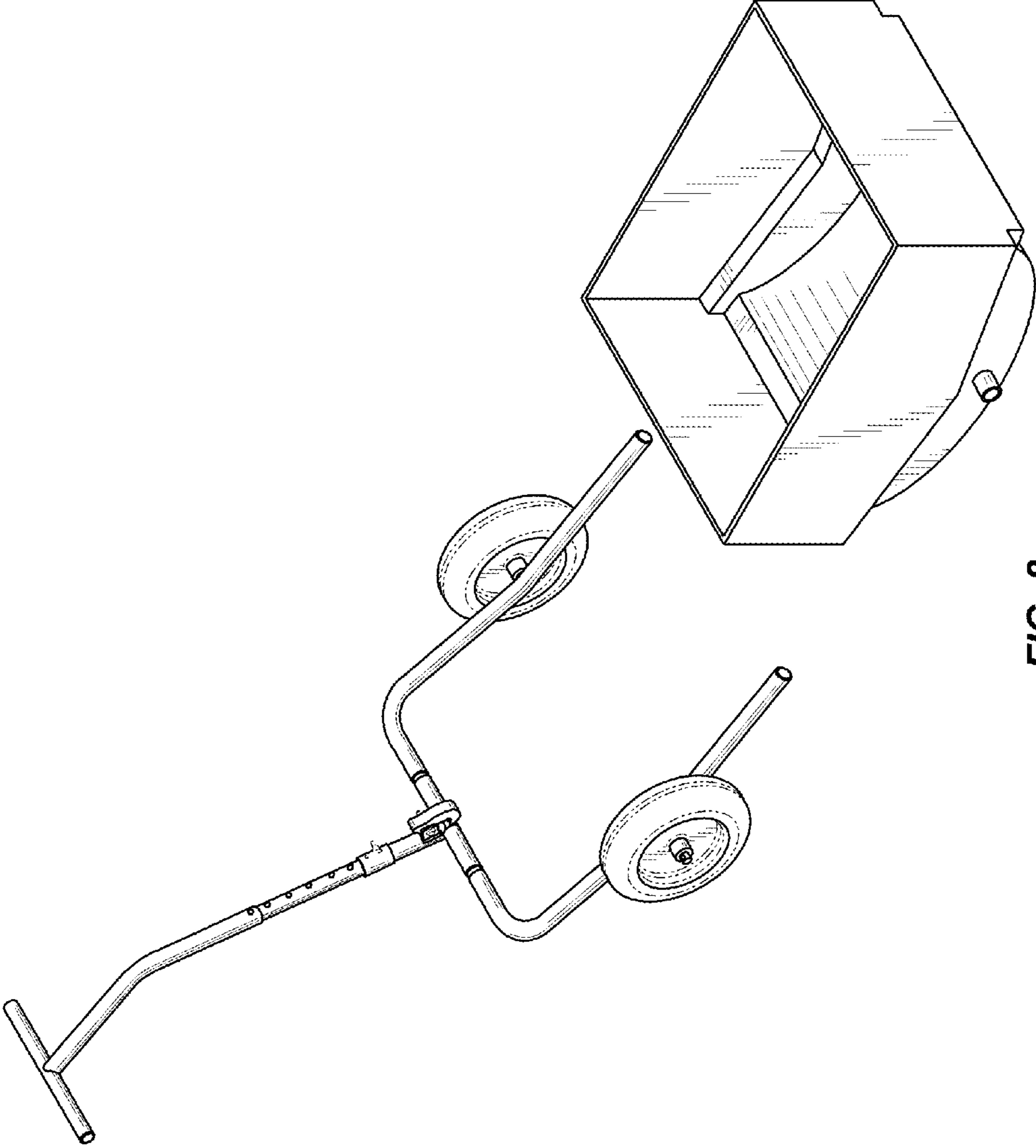

FIG. 8

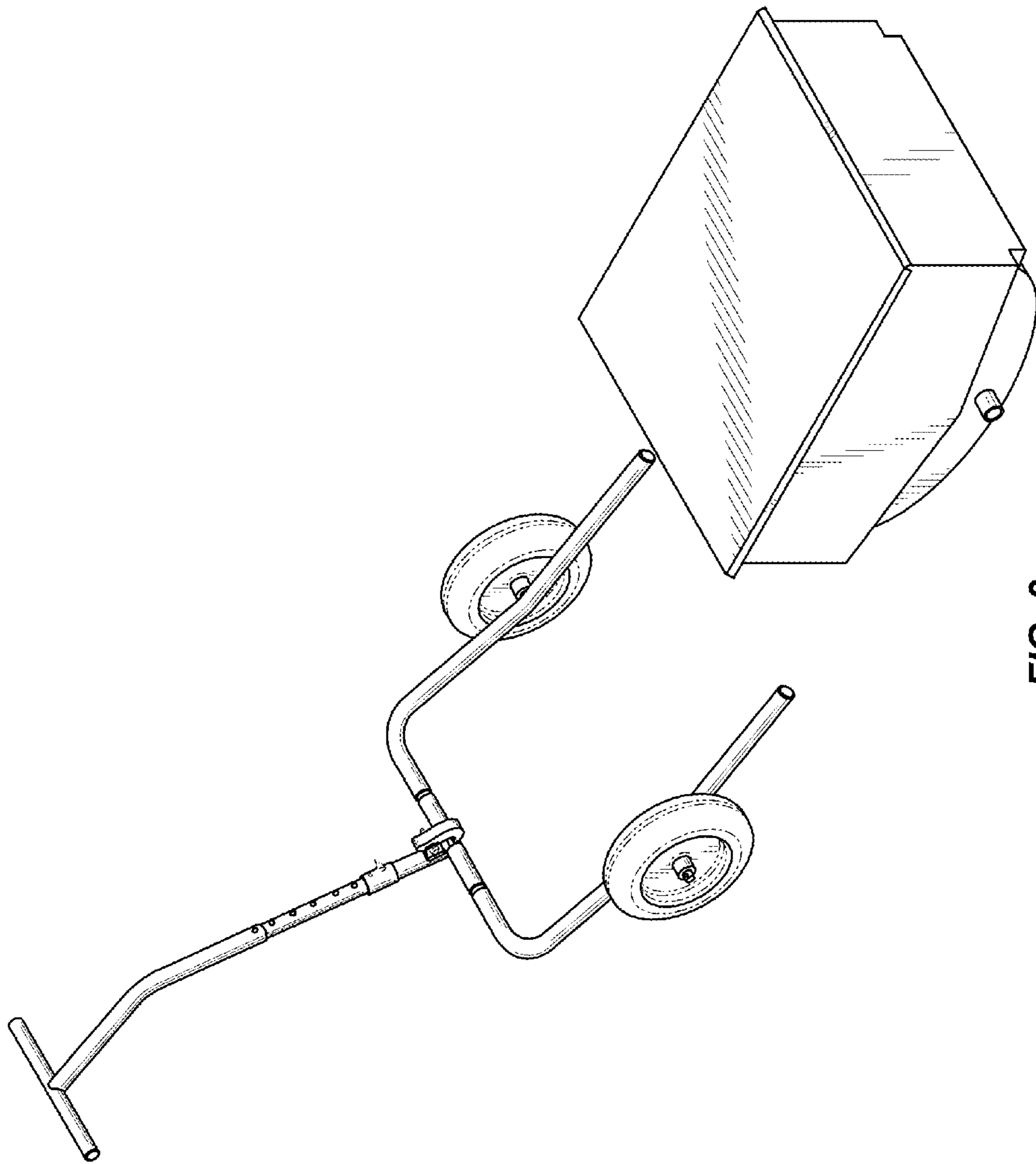

FIG. 9

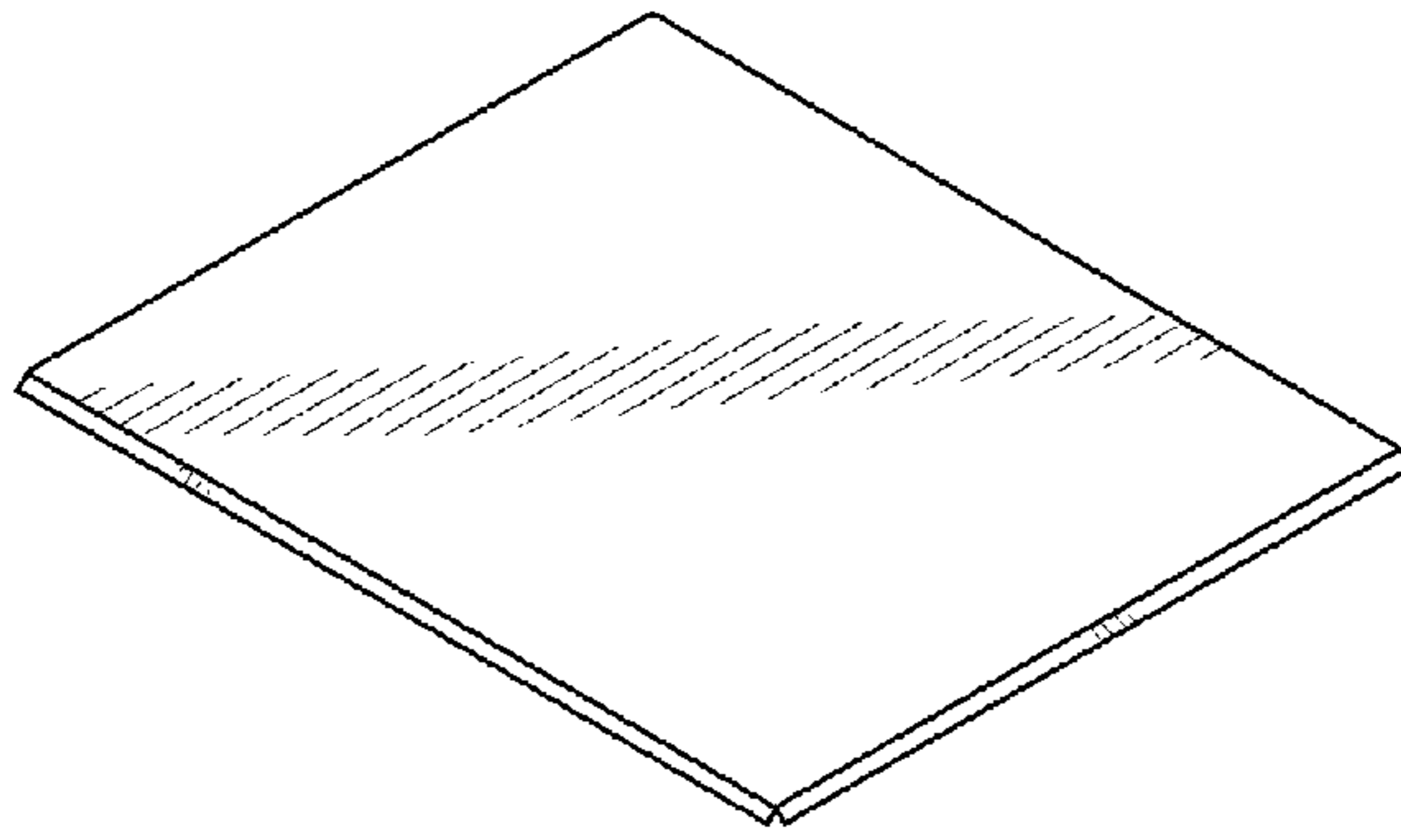

FIG. 10