



US00D672380S

(12) **United States Design Patent**
de la Hamayde

(10) **Patent No.:** **US D672,380 S**

(45) **Date of Patent:** **** Dec. 11, 2012**

(54) **LAMINATING MACHINE**

(75) **Inventor:** **Sebastien de la Hamayde**, Leicester
(GB)

(73) **Assignee:** **Vivid Laminating Technologies, Ltd.**,
Coalville, Leicestershire (GB)

(**) **Term:** **14 Years**

(21) **Appl. No.:** **29/419,437**

(22) **Filed:** **Apr. 27, 2012**

(30) **Foreign Application Priority Data**

Jan. 11, 2011 (EM) 001299994

(51) **LOC (9) Cl.** **15-99**

(52) **U.S. Cl.** **D15/146**

(58) **Field of Classification Search** D15/145-146;
53/374.9, 389.2, 389.3, 390, 510, 512; 100/160,
100/176; 101/9; 156/215, 286, 299, 320,
156/382, 461, 464, 468, 479, 483, 484, 490,
156/515, 555, 556, 560, 582, 587, 583.1,
156/583.4, 583.9; 219/143; 493/256
See application file for complete search history.

(56) **References Cited**

U.S. PATENT DOCUMENTS

4,418,511 A * 12/1983 Collin 53/427
D332,623 S * 1/1993 Iwanaga D18/53
D338,025 S * 8/1993 Washizaki et al. D15/145

D342,907 S * 1/1994 Kamatsuda D10/63
D347,013 S * 5/1994 Taguchi et al. D15/145
D366,623 S * 1/1996 Nguyen D10/63
D407,740 S * 4/1999 Ina et al. D18/53
D442,980 S * 5/2001 Johnson et al. D15/146
D445,126 S * 7/2001 Shimizu D18/53
D454,895 S * 3/2002 Sakata et al. D15/146
D475,083 S * 5/2003 Kusanagi D18/50
D523,070 S * 6/2006 Schneider D18/50
D544,533 S * 6/2007 Moliner et al. D18/53
D595,345 S * 6/2009 Yagi et al. D18/53
D595,346 S * 6/2009 Yamano et al. D18/53
D597,131 S * 7/2009 Yamano et al. D18/53

* cited by examiner

Primary Examiner — Patricia Palasik

(74) *Attorney, Agent, or Firm* — Clifford Kraft

(57) **CLAIM**

The ornamental design for a laminating machine, as shown and described.

DESCRIPTION

FIG. 1 is a perspective view of an embodiment of the invention.

FIG. 2 is a front view thereof.

FIG. 3 is a left side view thereof.

FIG. 4 is top view thereof.

FIG. 5 is a back view thereof.

FIG. 6 is a bottom view thereof; and,

FIG. 7 is a right side view thereof.

1 Claim, 7 Drawing Sheets

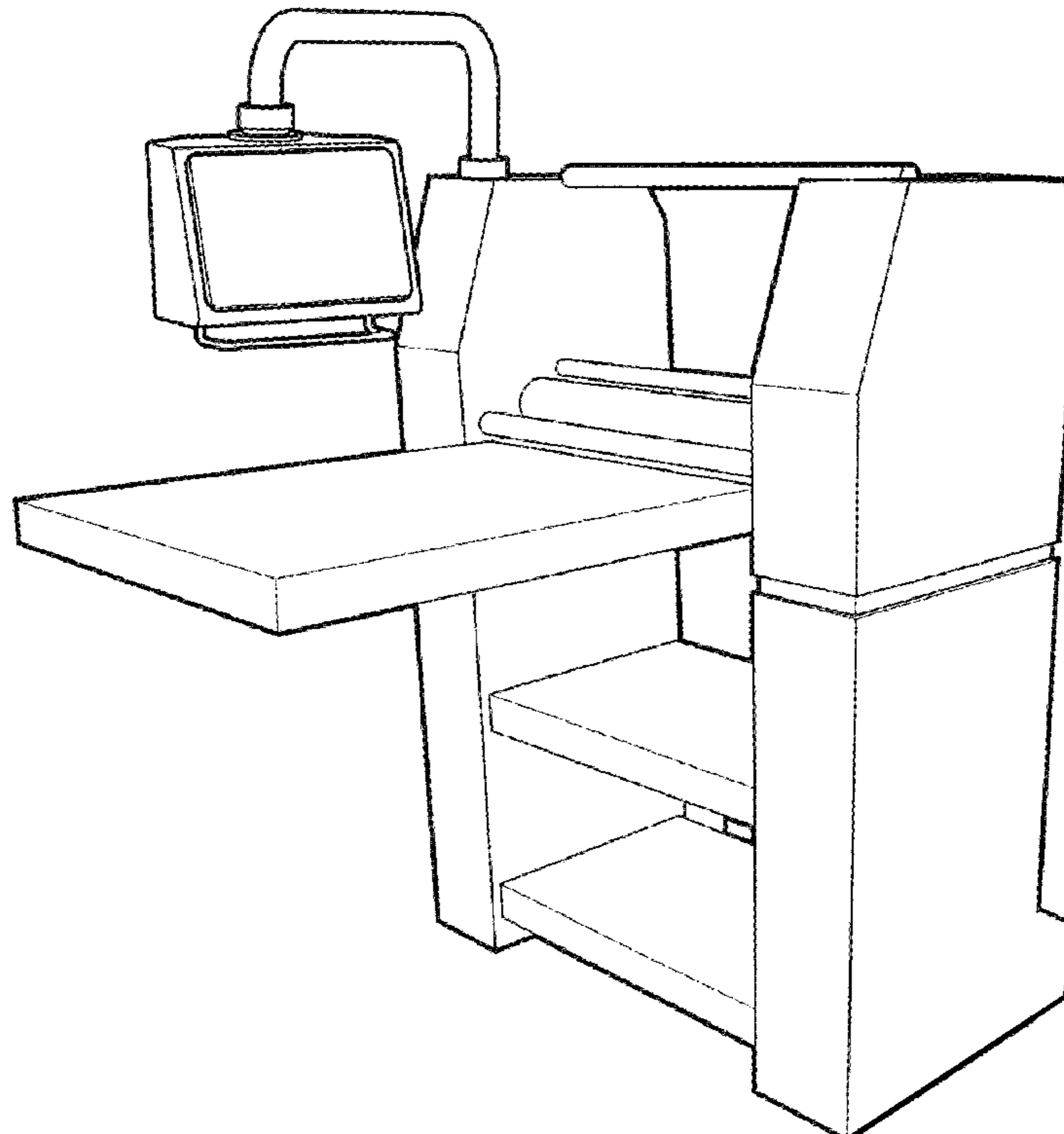

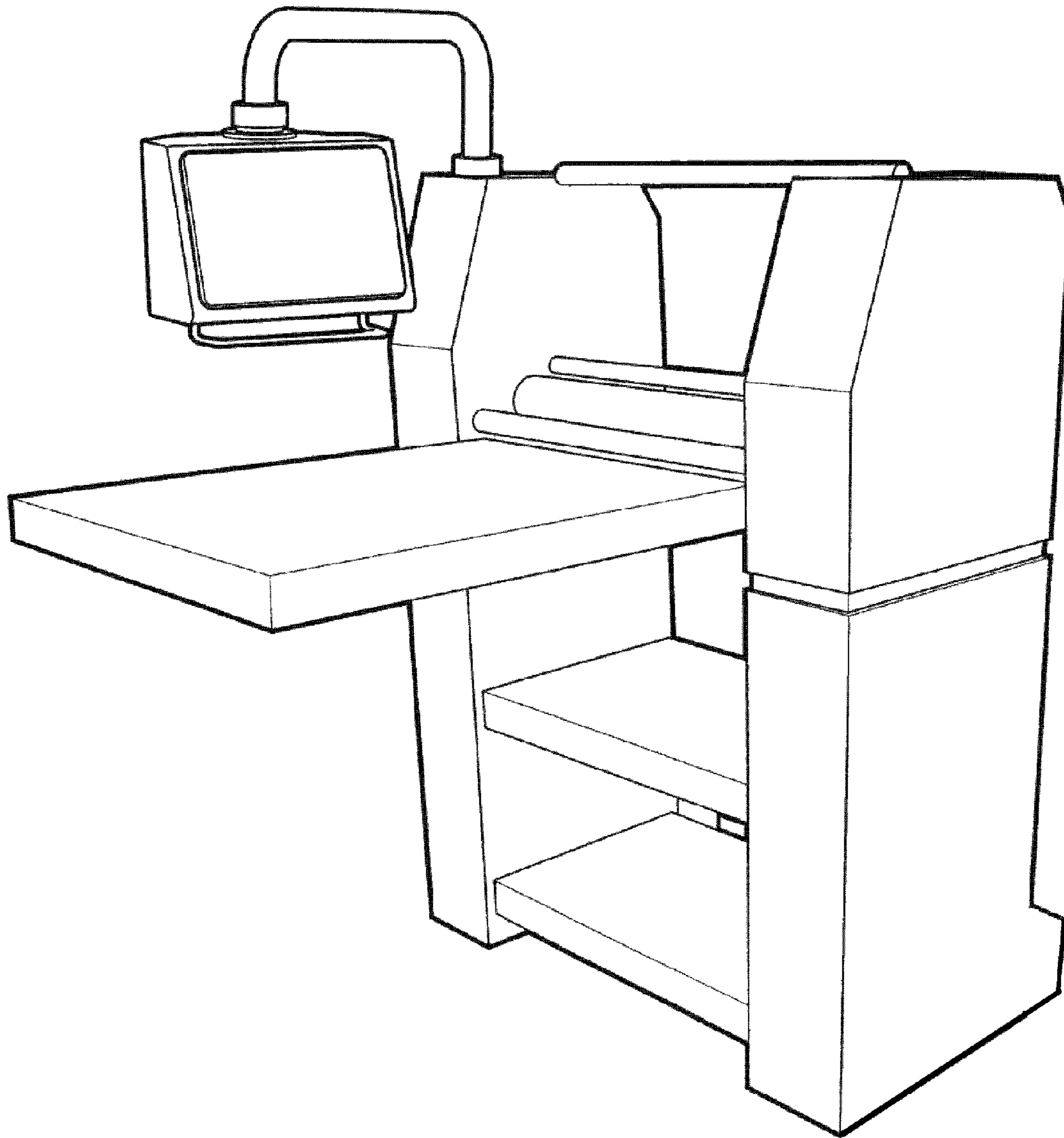

FIG. 1

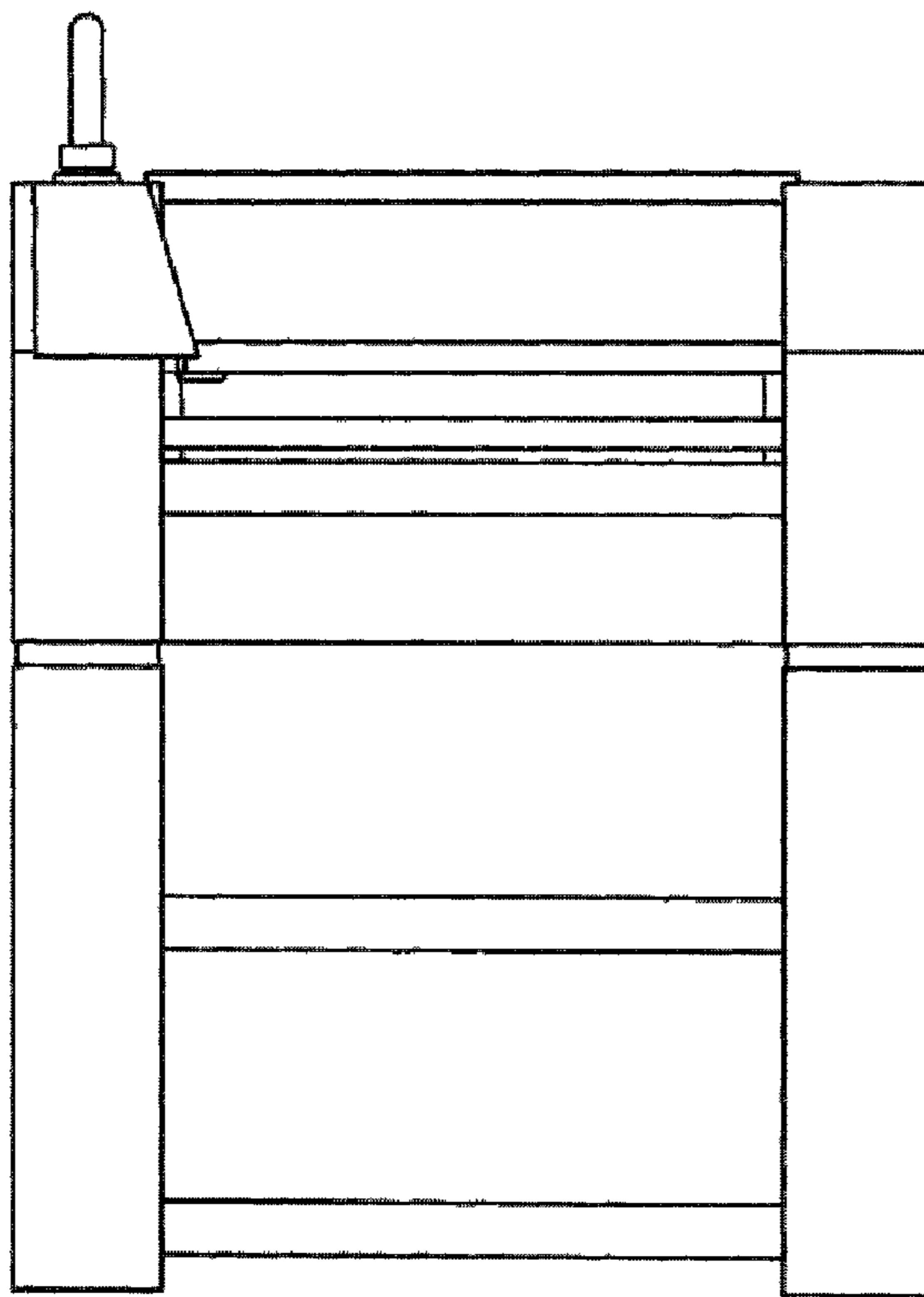

FIG. 2

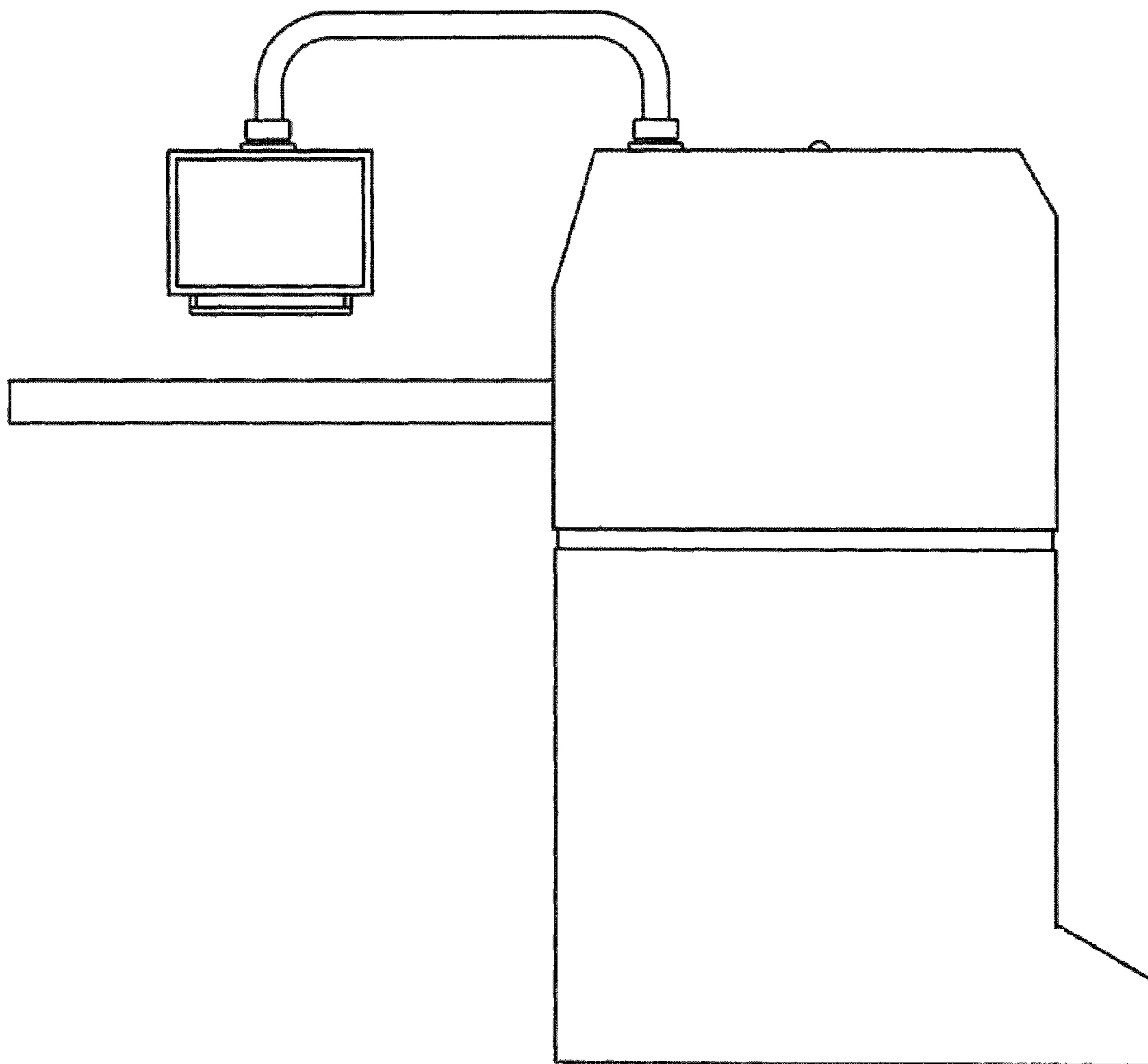

FIG. 3

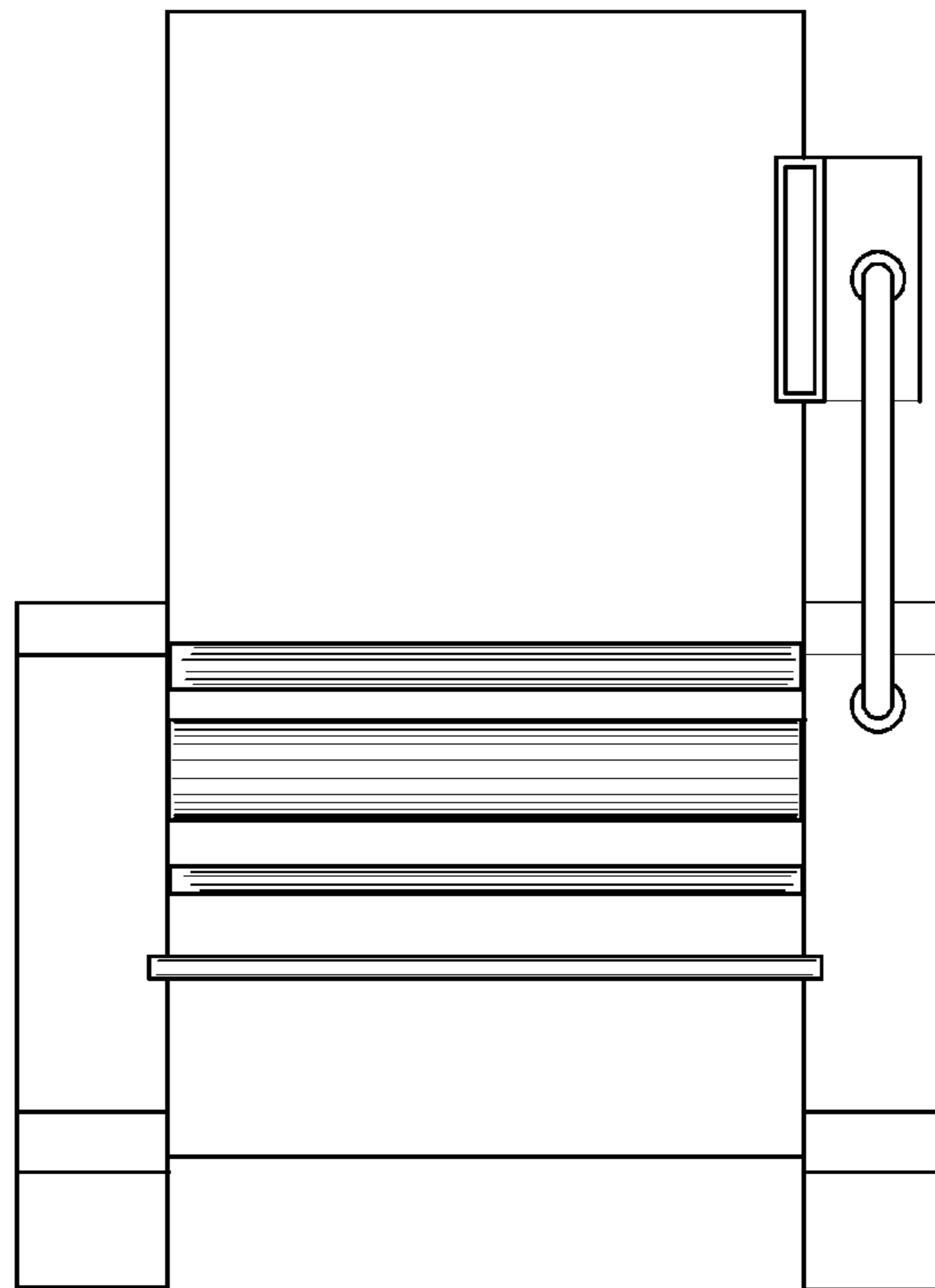

FIG. 4

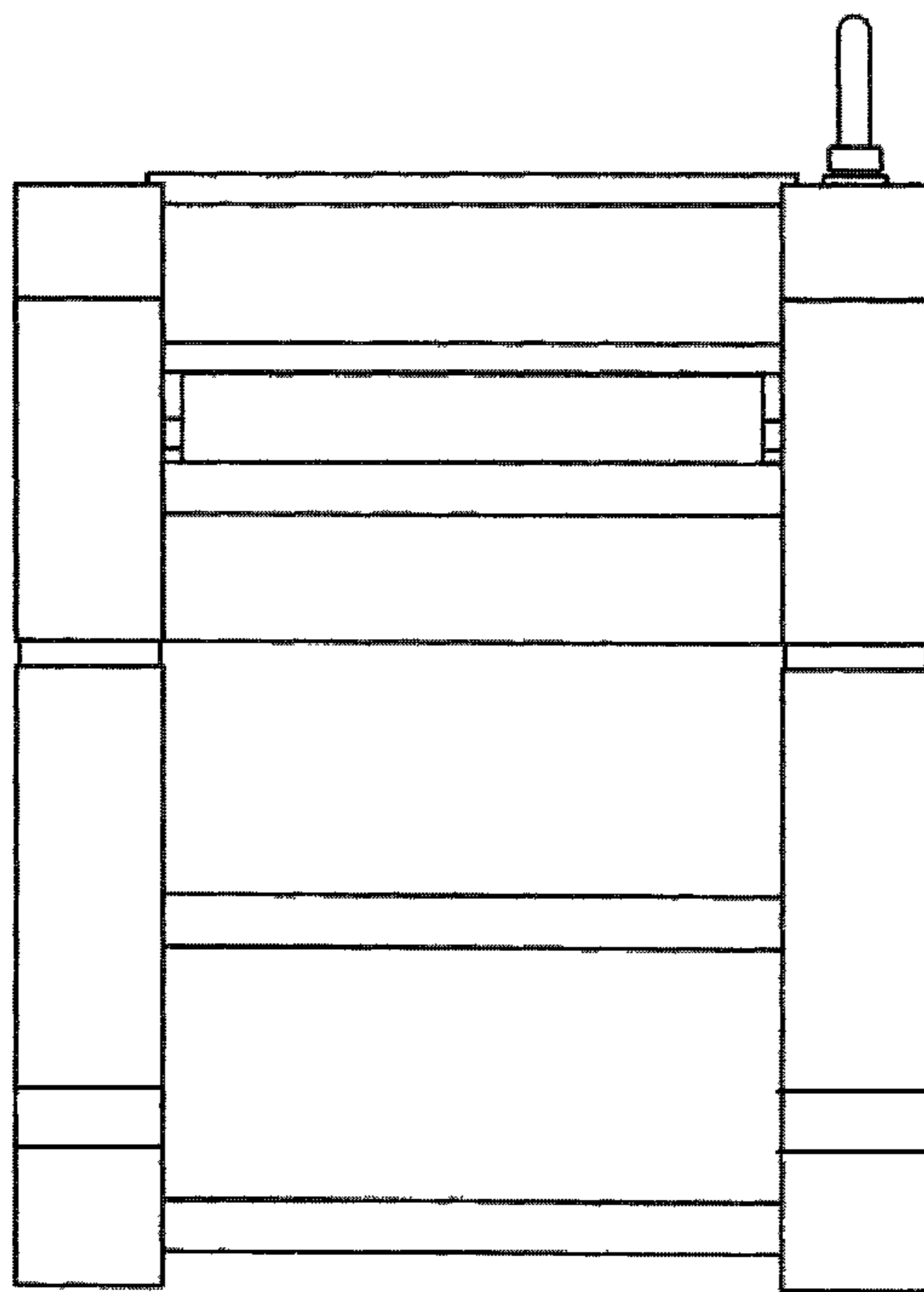

FIG. 5

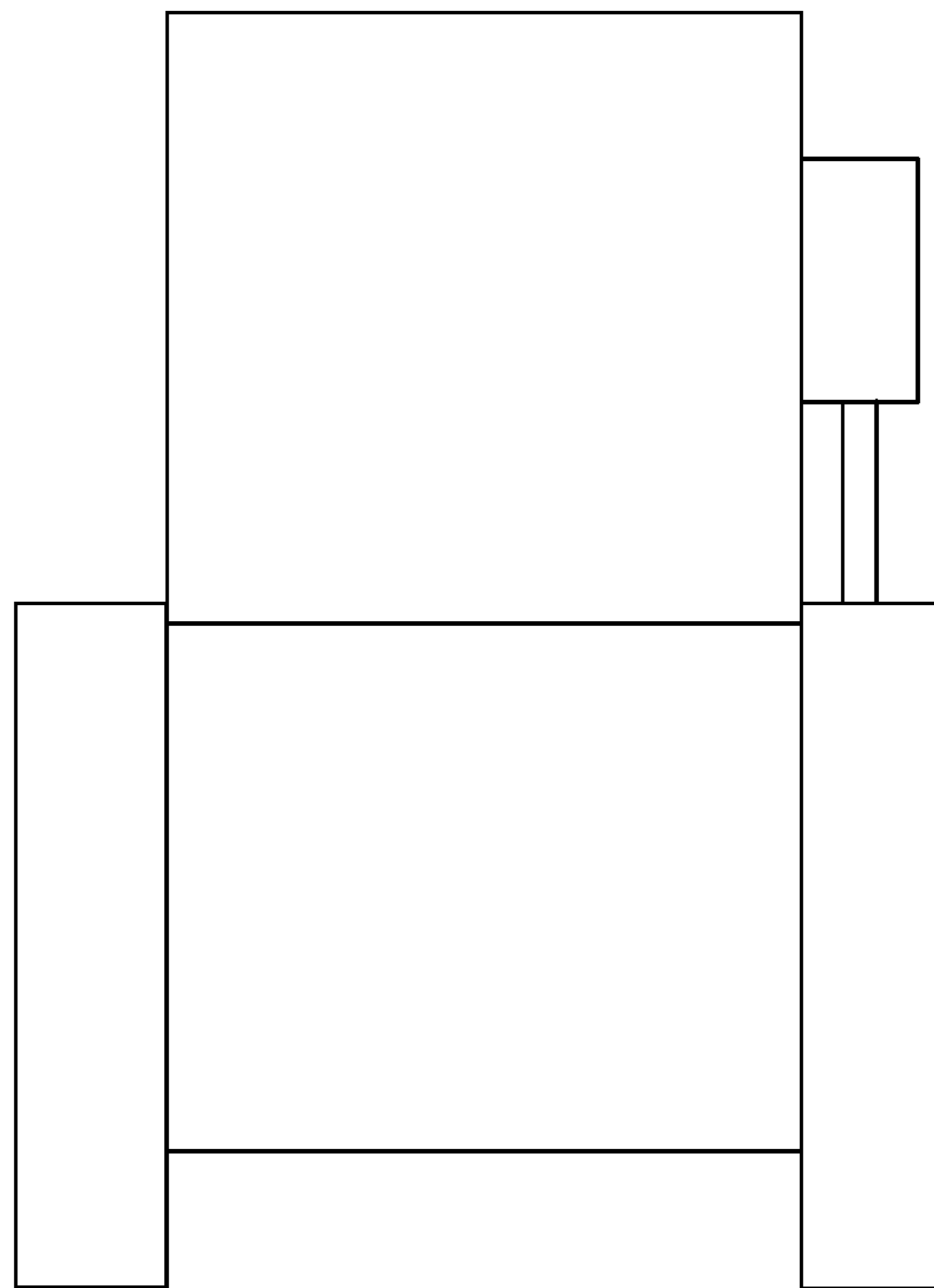

FIG. 6

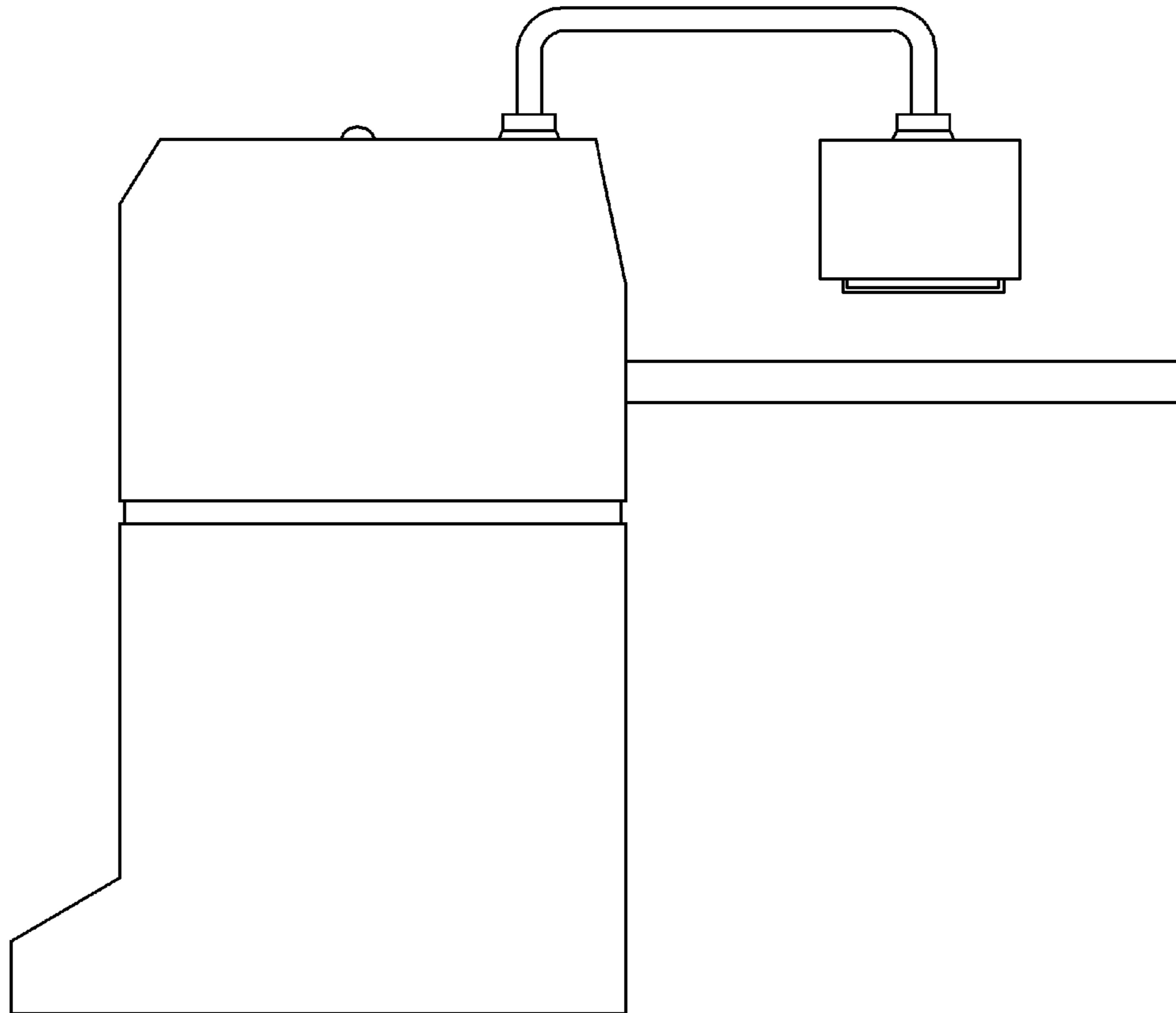

FIG. 7