



US00D672160S

(12) **United States Design Patent**  
**Wagener**

(10) **Patent No.:** **US D672,160 S**

(45) **Date of Patent:** **\*\* Dec. 11, 2012**

(54) **VEHICLE SEAT**

(75) Inventor: **Karl-Heinz Wagener**, Guetersloh (DE)

(73) Assignee: **Isringhausen GmbH & Co. KG**,  
Lemgo (DE)

(\*\*) Term: **14 Years**

(21) Appl. No.: **29/396,115**

(22) Filed: **Jun. 24, 2011**

(30) **Foreign Application Priority Data**

Dec. 29, 2010 (EM) ..... 001799610-0001

(51) **LOC (9) Cl.** ..... **06-01**

(52) **U.S. Cl.** ..... **D6/356**

(58) **Field of Classification Search** ..... D6/334-336,  
D6/356, 367, 368, 374, 375, 381, 500-502;  
297/232, 353, 354.1, 396, 452.21, 452.24,  
297/452.26, 452.29, 452.34, 452.35, 468

See application file for complete search history.

(56) **References Cited**

**U.S. PATENT DOCUMENTS**

D315,255 S *	3/1991	Beermann	.....	D6/356
D426,392 S *	6/2000	Ott et al.	.....	D6/356
D509,077 S *	9/2005	Beermann et al.	.....	D6/356
D605,879 S *	12/2009	Krauss et al.	.....	D6/500
D612,163 S *	3/2010	Wagener	.....	D6/356
D615,311 S *	5/2010	Fleming	.....	D6/356
D617,104 S *	6/2010	Wagener	.....	D6/356
D651,001 S *	12/2011	Fleming	.....	D6/356
D651,002 S *	12/2011	Fleming	.....	D6/356
D651,003 S *	12/2011	Fleming	.....	D6/356
D651,004 S *	12/2011	Fleming	.....	D6/356

D651,819 S *	1/2012	Fleming	.....	D6/356
D653,866 S *	2/2012	Wada	.....	D6/356
2008/0073967 A1 *	3/2008	Whalen et al.	.....	297/468

\* cited by examiner

*Primary Examiner* — Mimosa De

(74) *Attorney, Agent, or Firm* — Abelman, Frayne & Schwab

(57) **CLAIM**

The ornamental design of a vehicle seat, as shown and described.

**DESCRIPTION**

FIG. 1 is a perspective view of a first embodiment of the vehicle seat;

FIG. 2 is a front elevation view of the first embodiment of the vehicle seat;

FIG. 3 is a rear elevation view of the first embodiment of the vehicle seat;

FIG. 4 is a right side elevation view of the first embodiment of the vehicle seat;

FIG. 5 is a left side elevation view of the first embodiment of the vehicle seat;

FIG. 6 is a top plan view of the first embodiment of the vehicle seat;

FIG. 7 is a perspective view of a second embodiment of the vehicle seat;

FIG. 8 is a front elevation view of the second embodiment of the vehicle seat;

FIG. 9 is a rear elevation view of the second embodiment of the vehicle seat;

FIG. 10 is a right side elevation view of the second embodiment of the vehicle seat;

FIG. 11 is a left side elevation view of the second embodiment of the vehicle seat; and,

FIG. 12 is a top plan view of the second embodiment of the vehicle seat.

The broken lines shown in the drawings represent environmental elements only, and form no part of the claimed design.

**1 Claim, 6 Drawing Sheets**

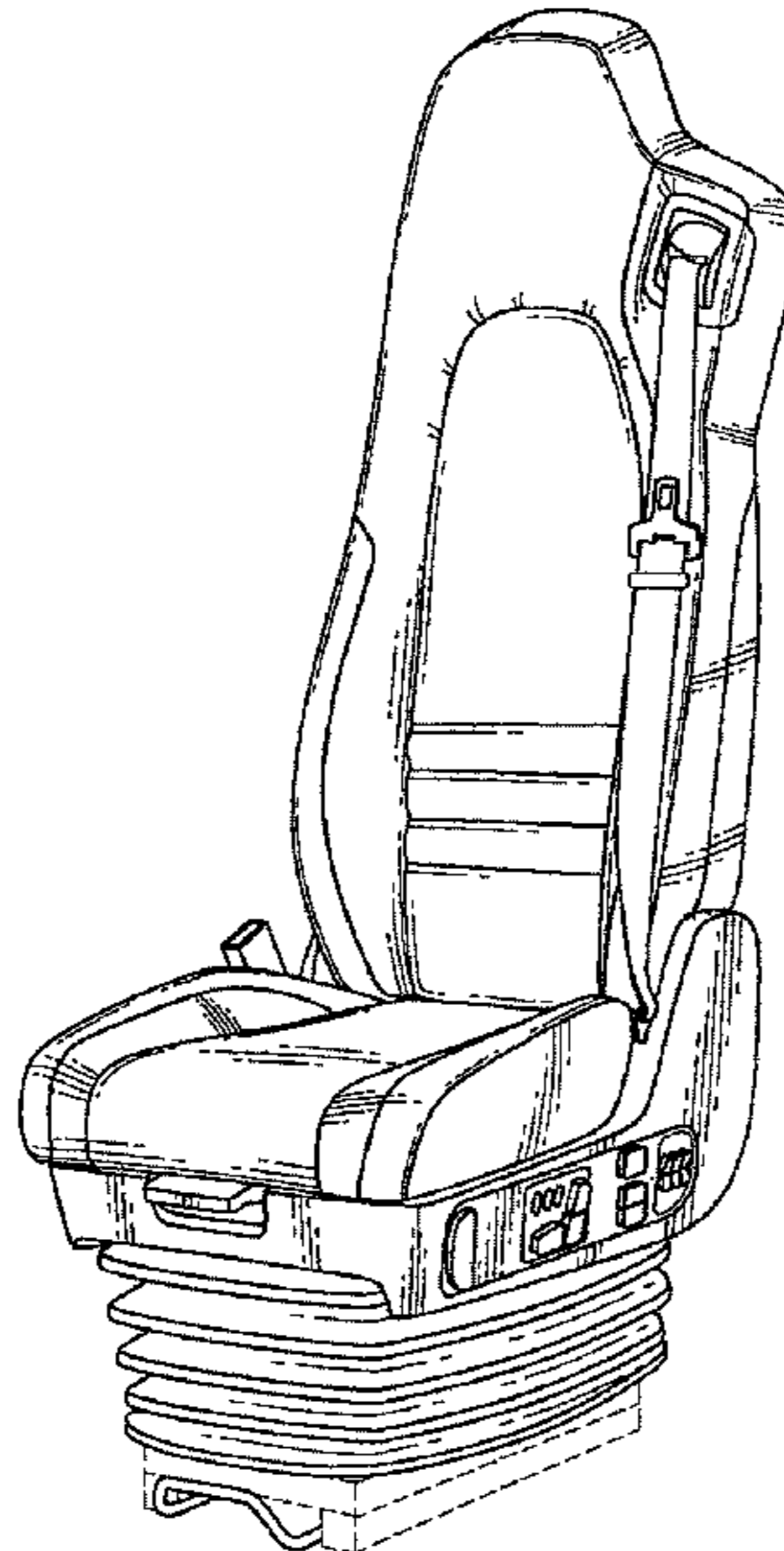
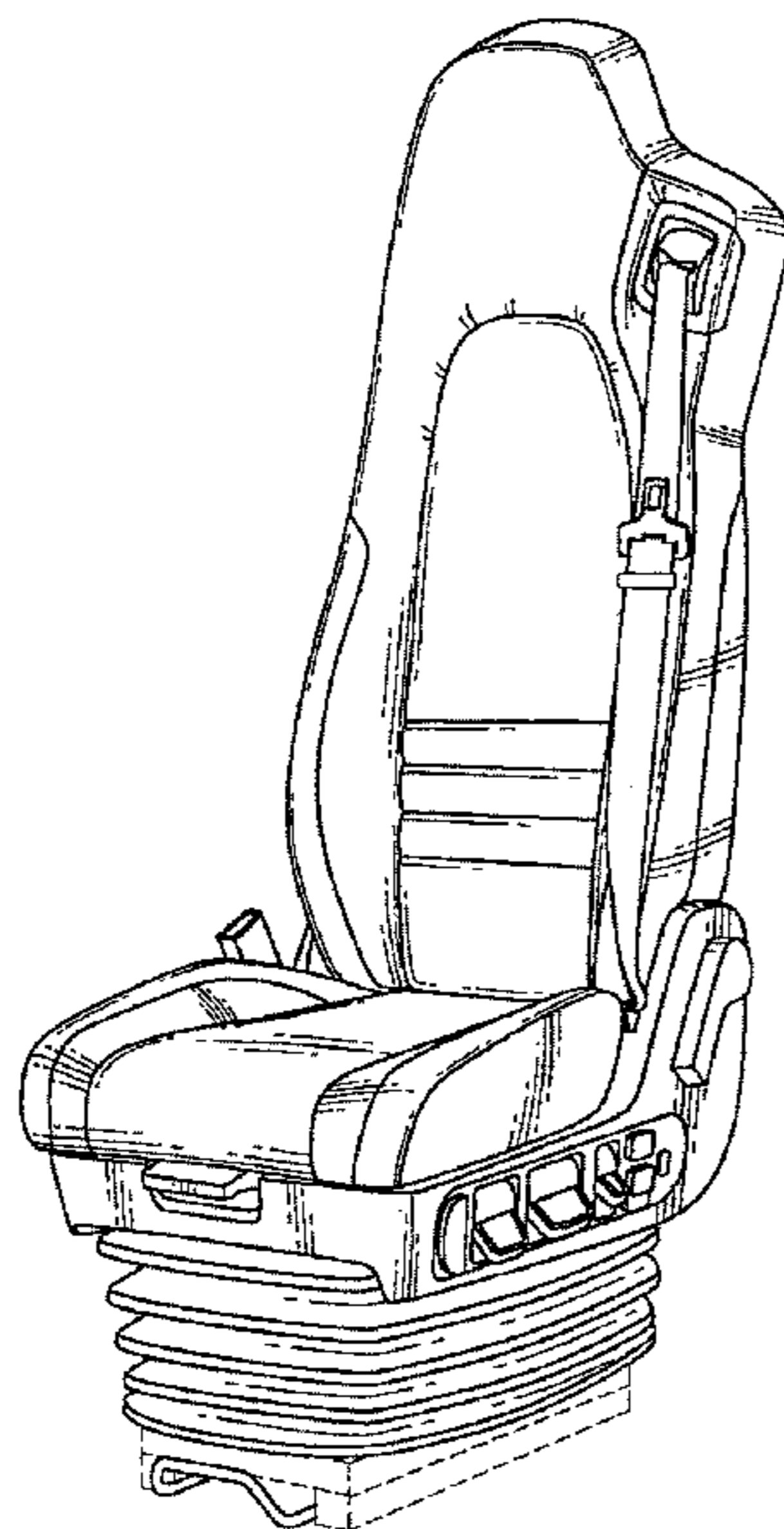

FIG. 3

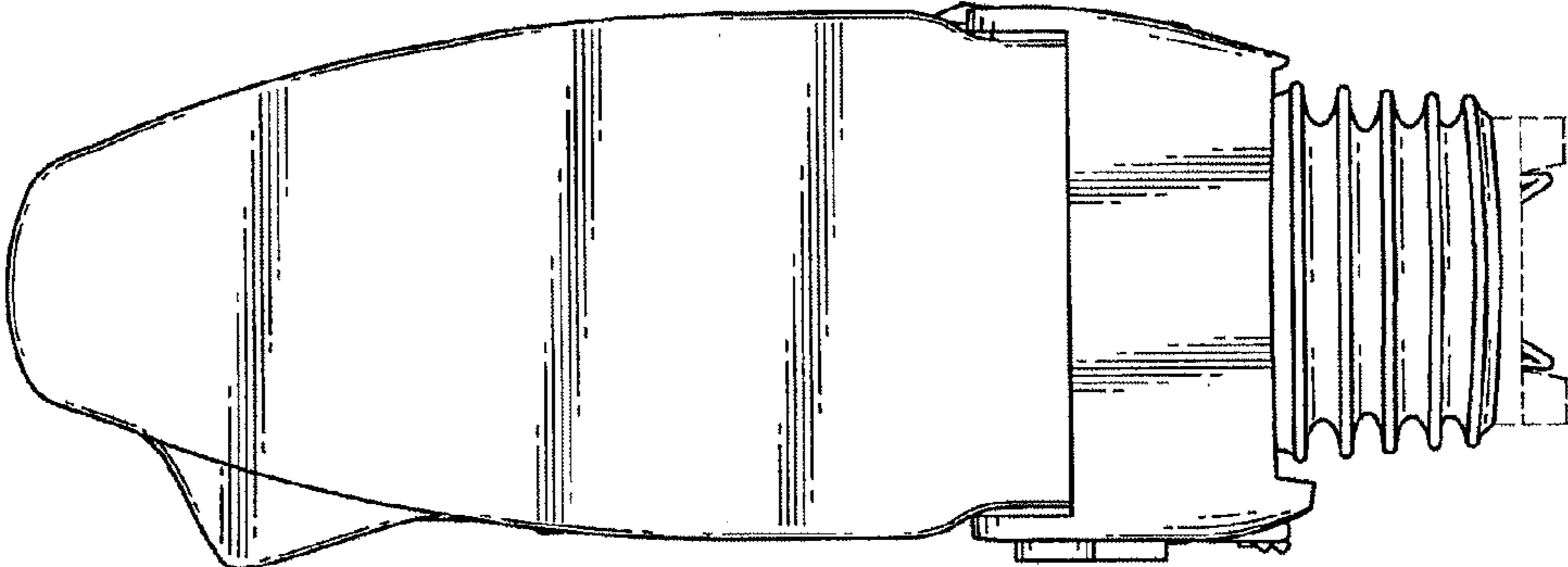

FIG. 2

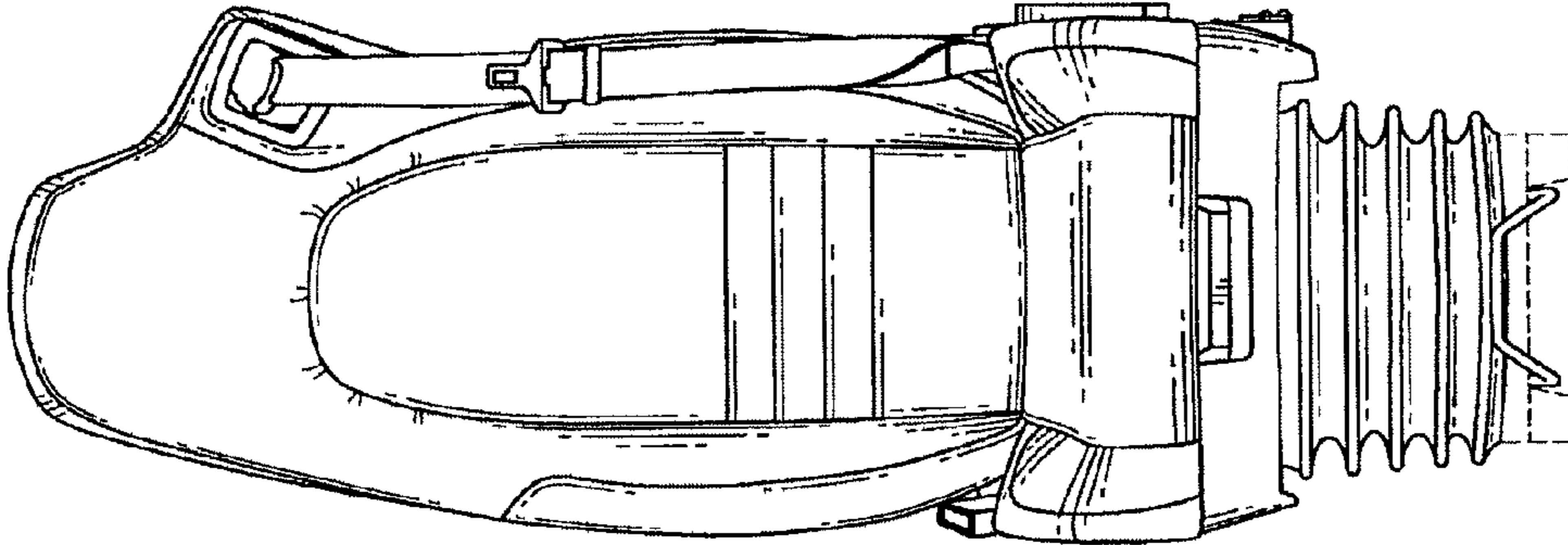
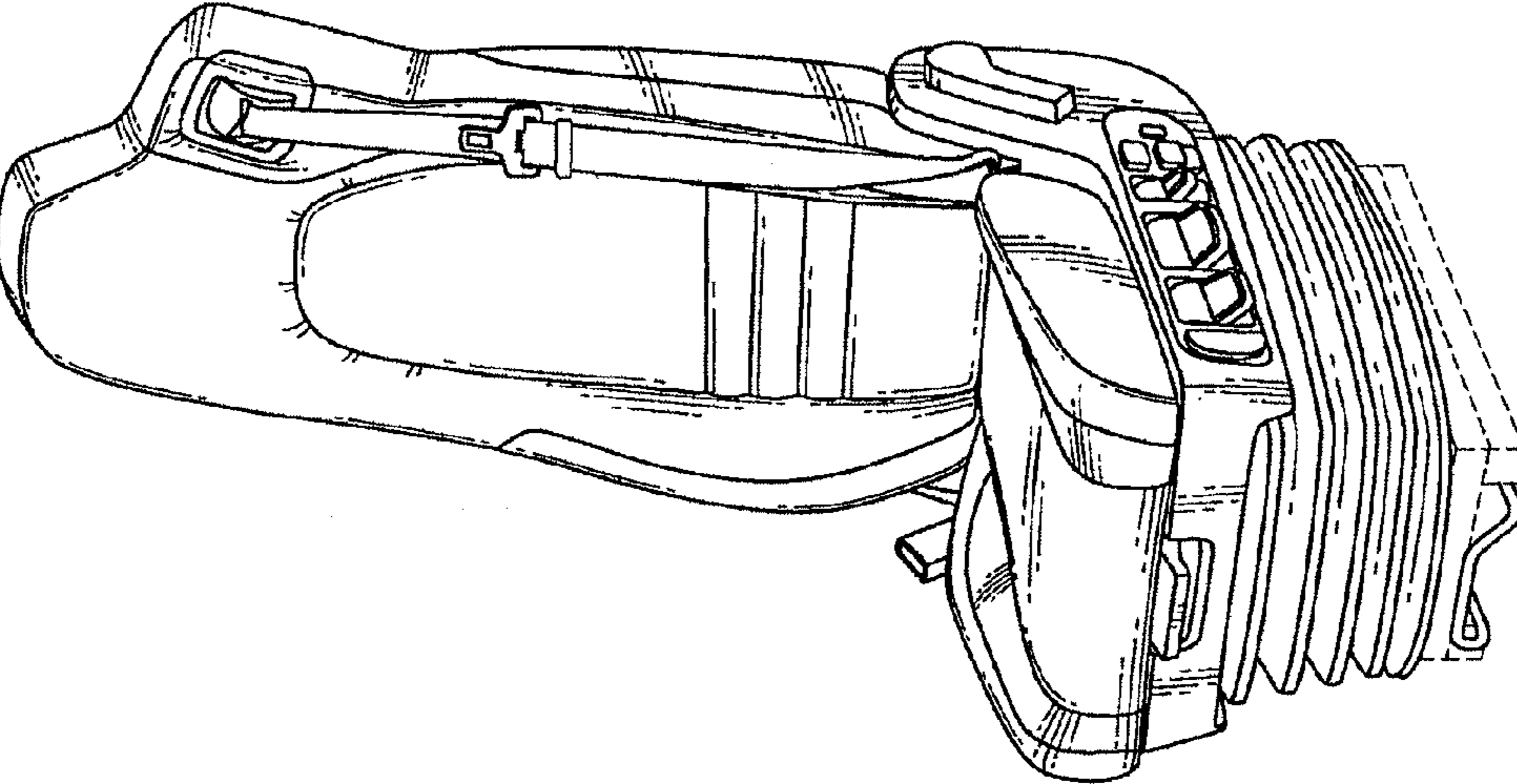

FIG. 1



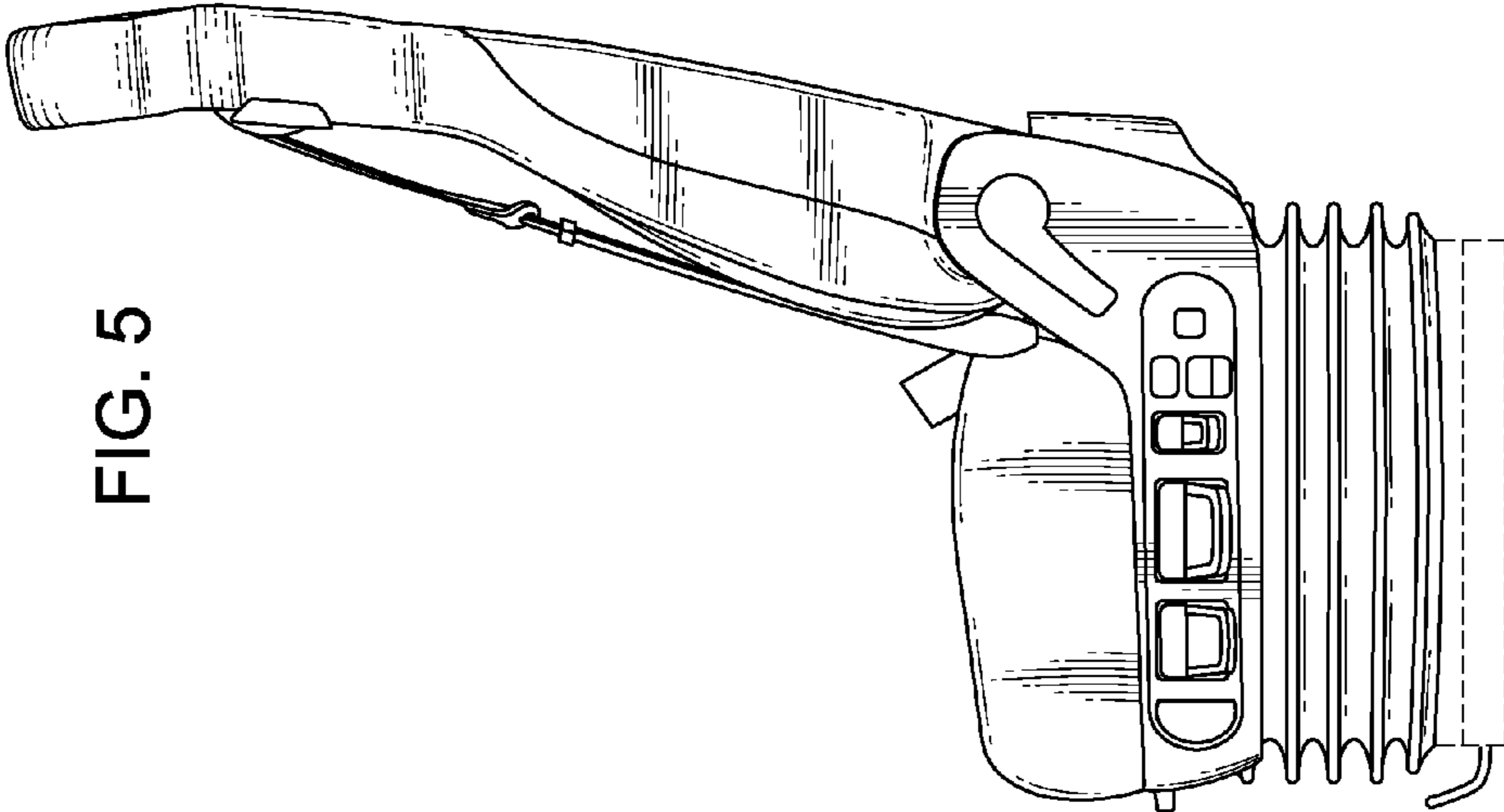

FIG. 5

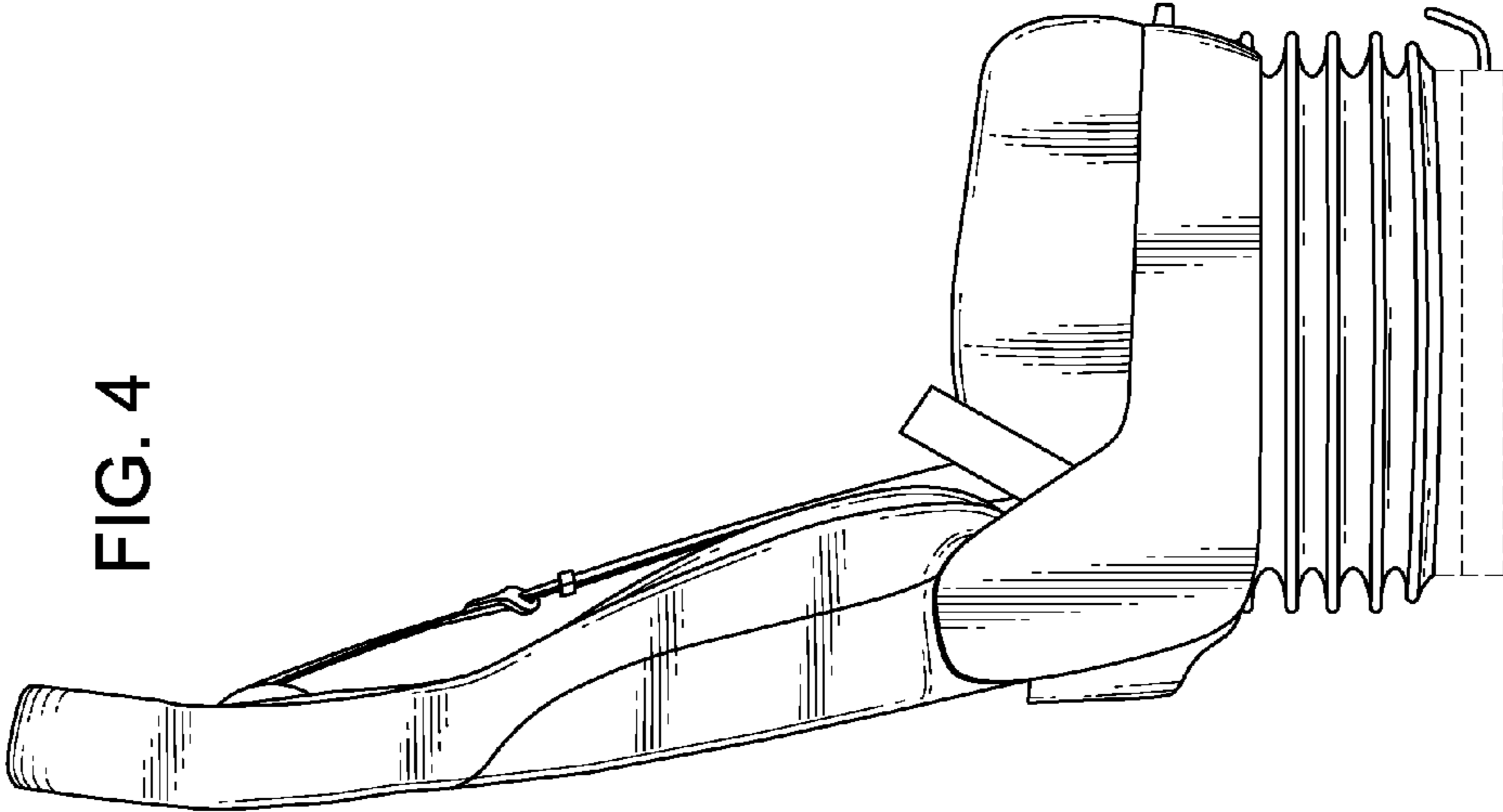

FIG. 4

FIG. 6

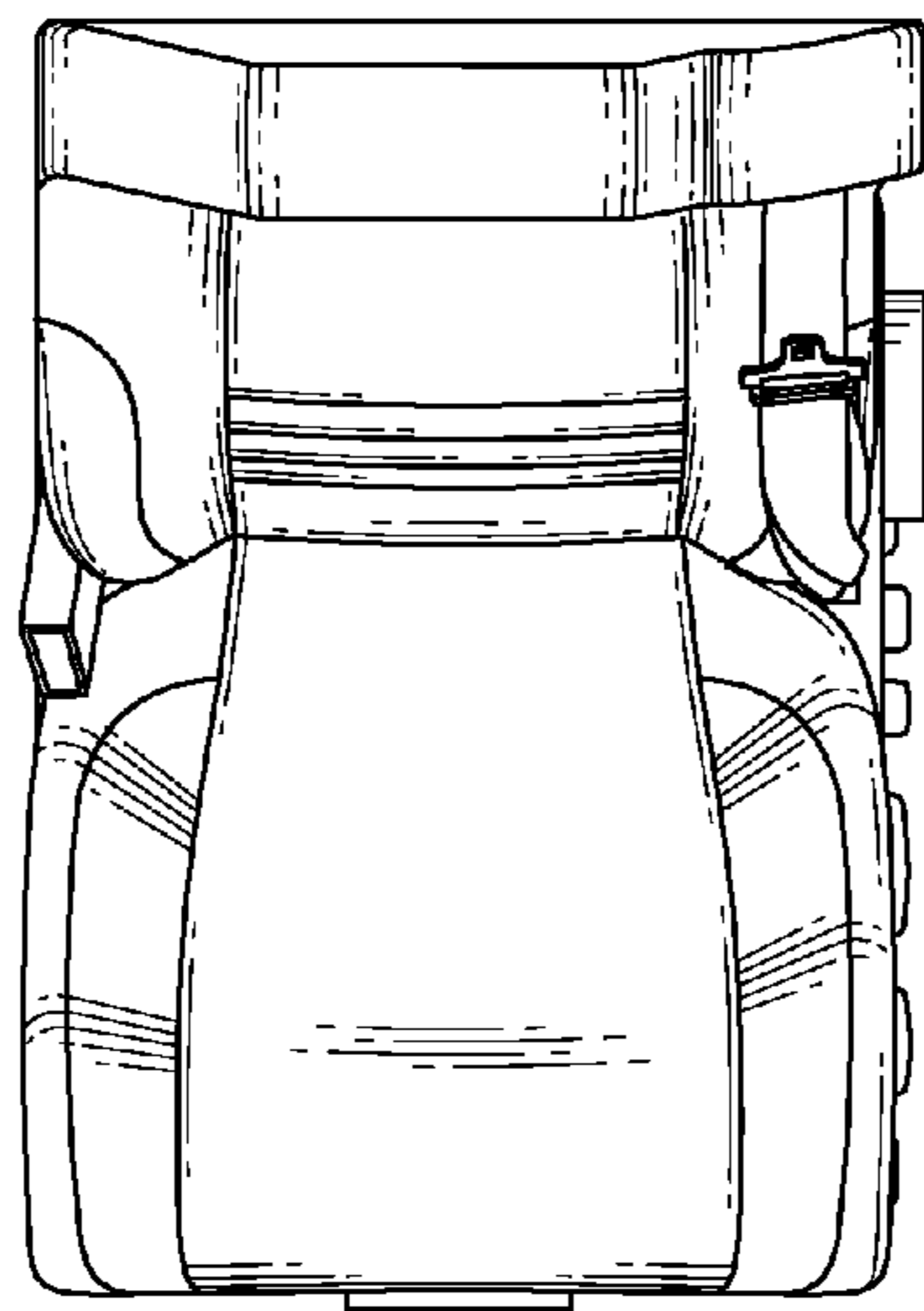

FIG. 9

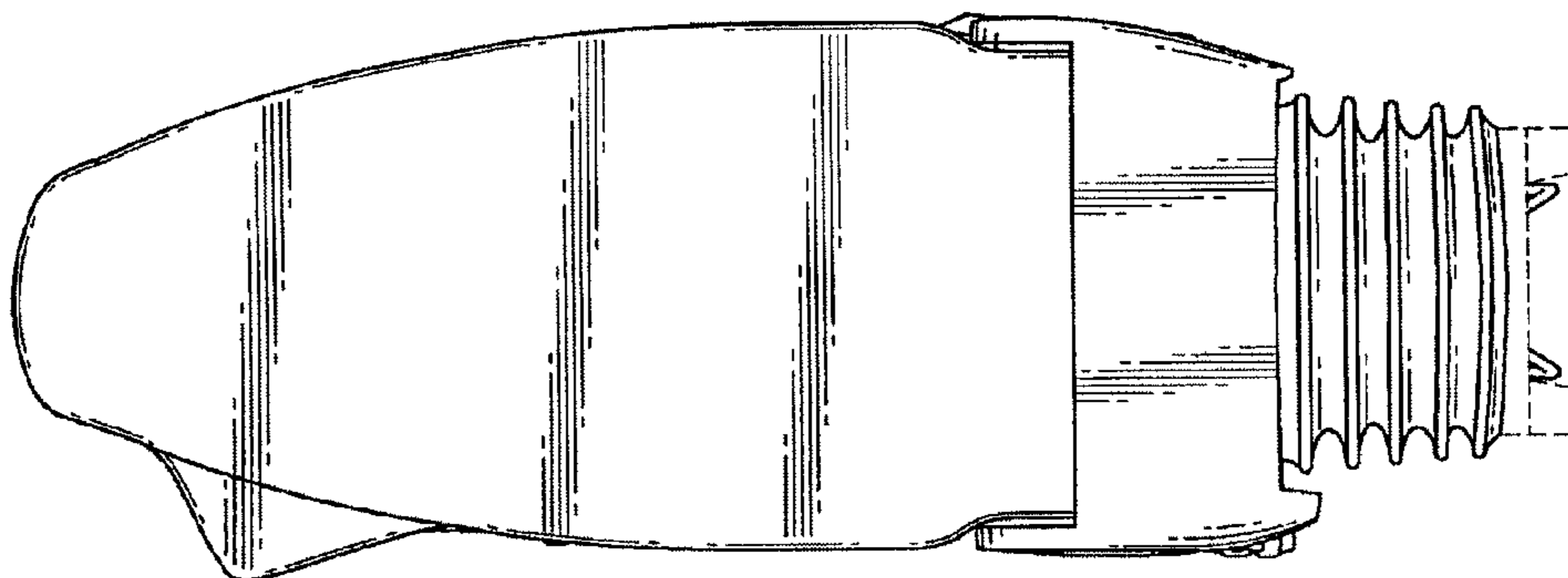

FIG. 8

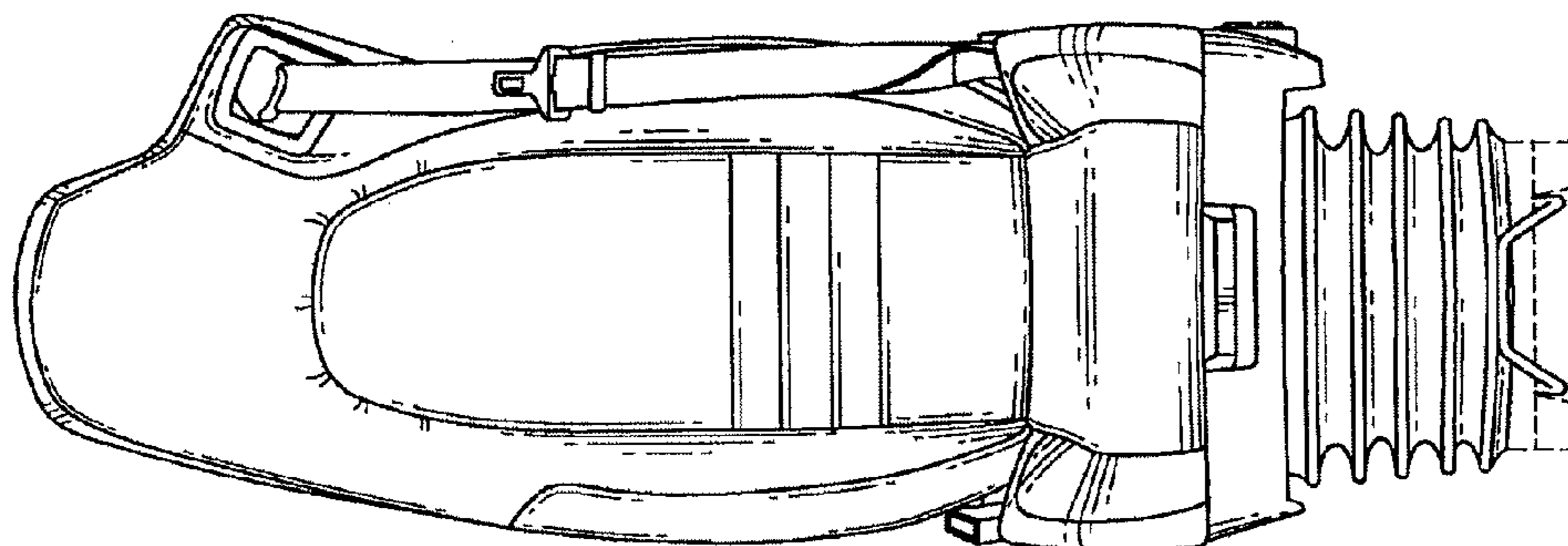
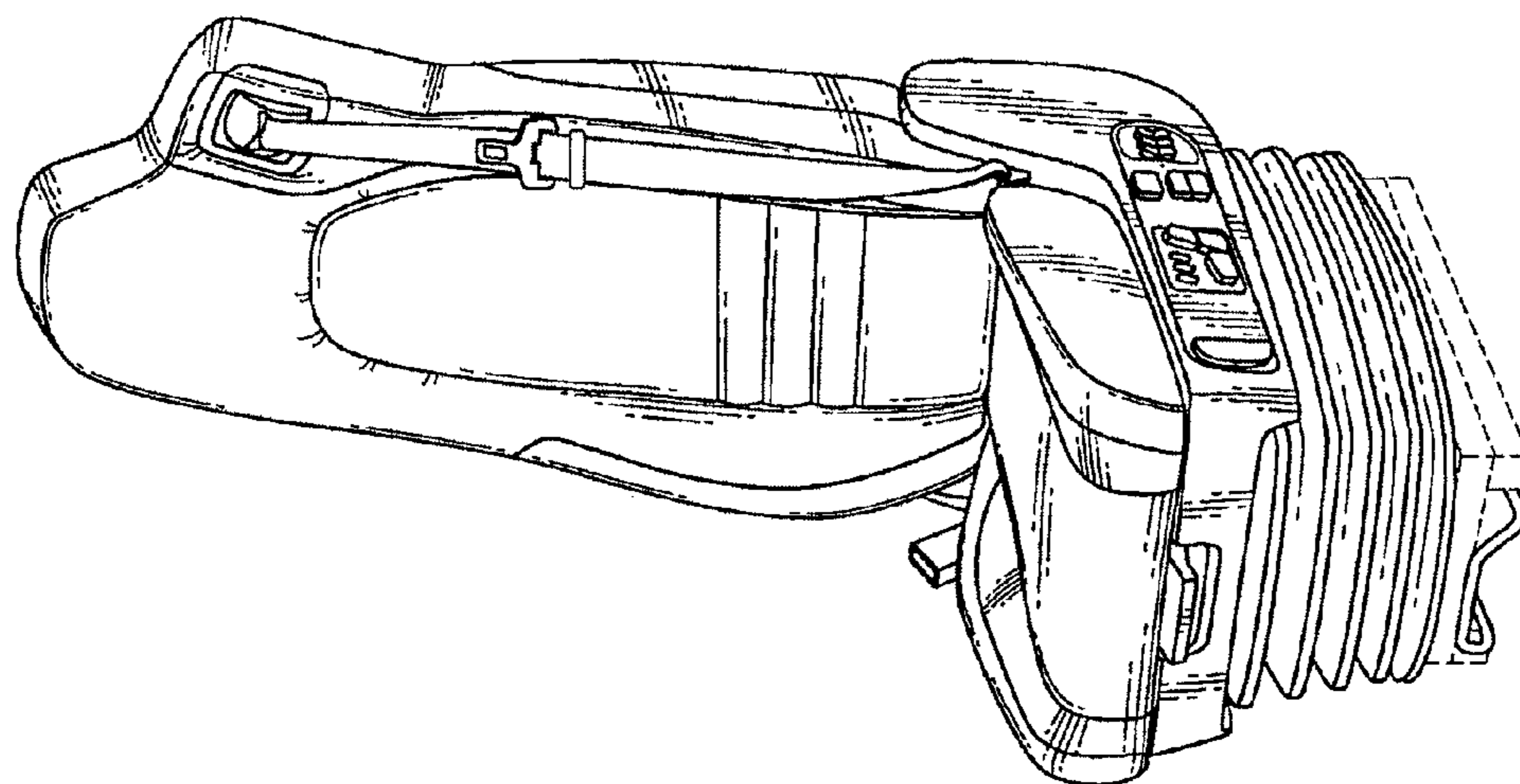

FIG. 7



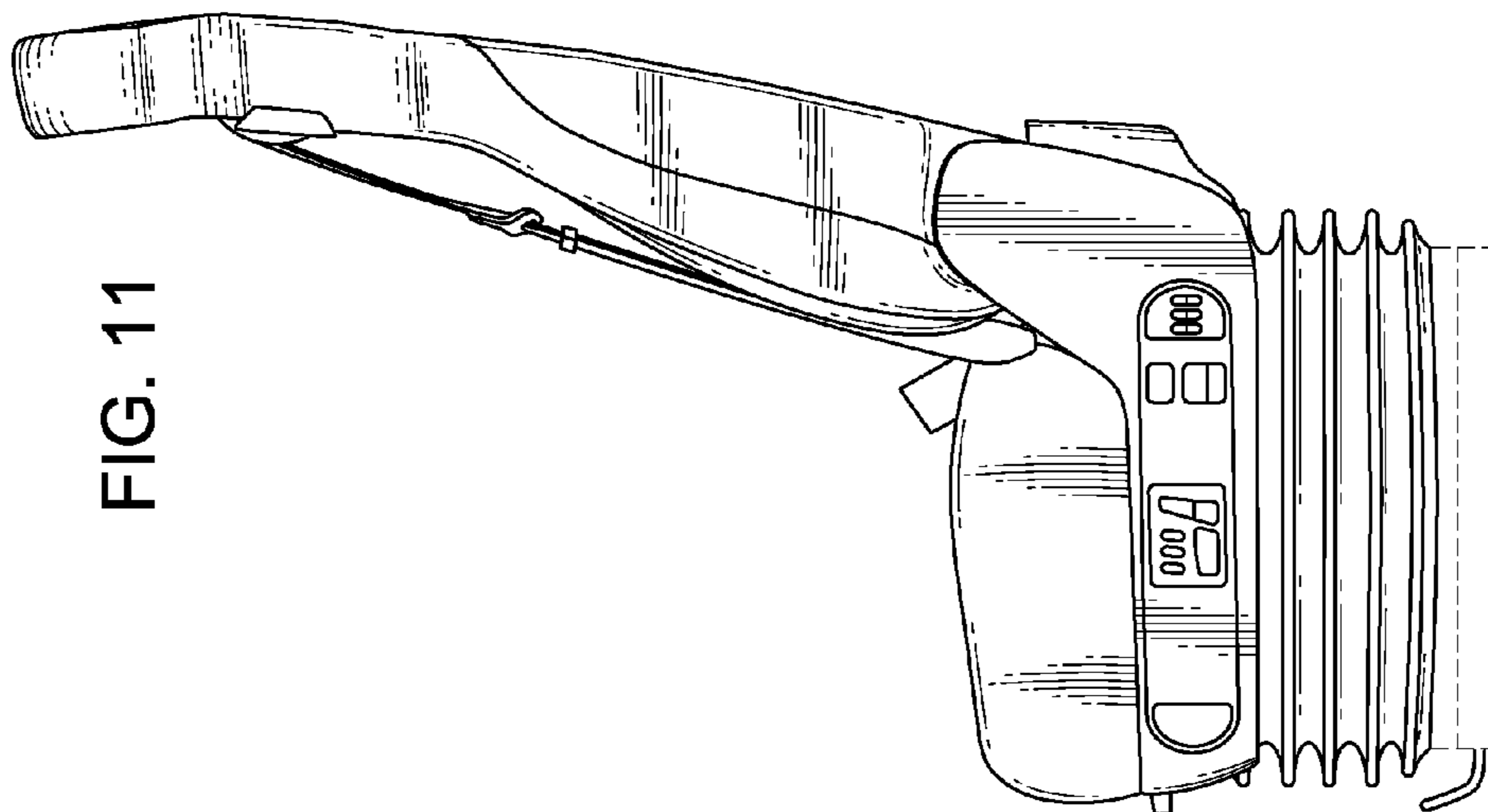

FIG. 11

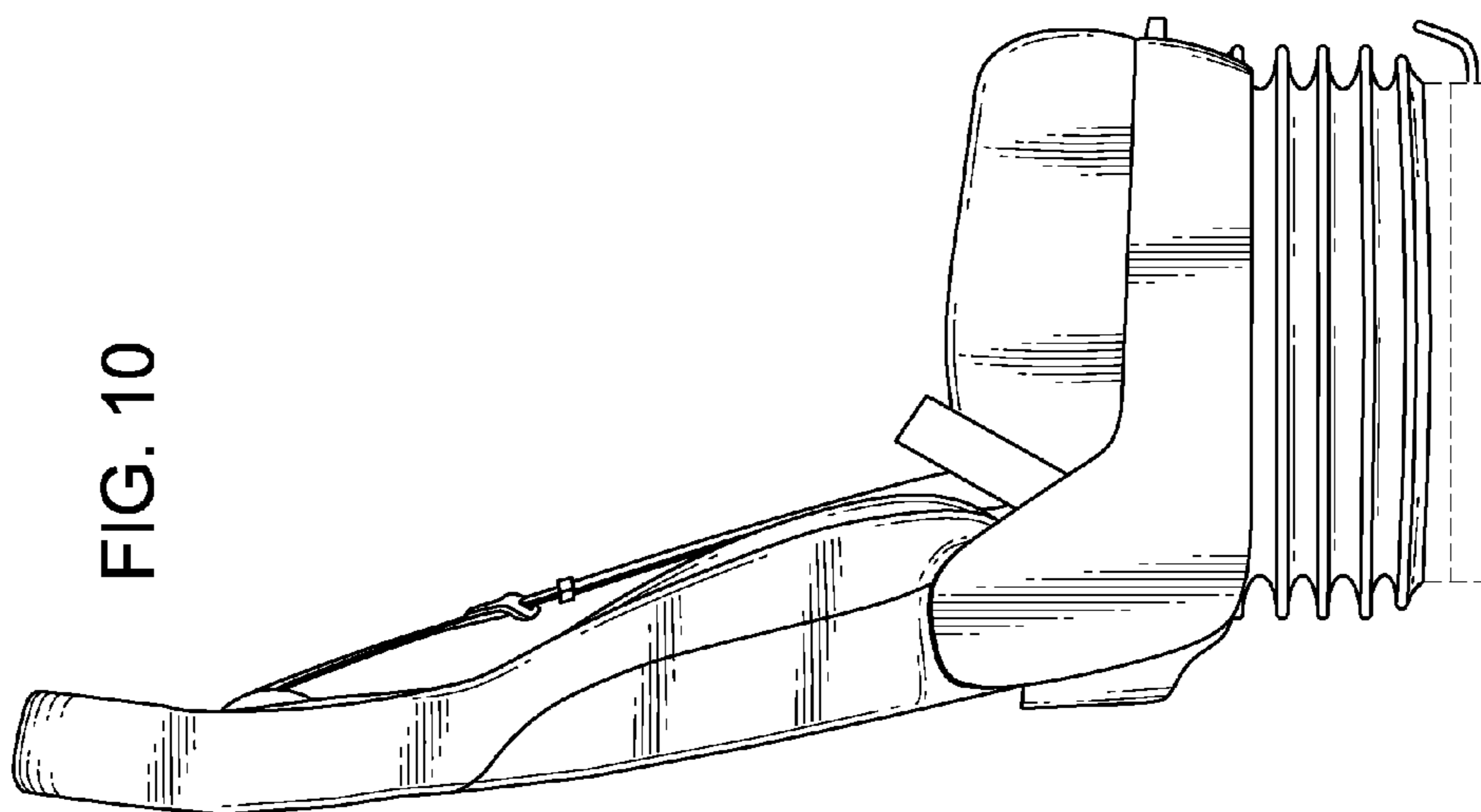

FIG. 10

FIG. 12

