



US00D672114S

(12) **United States Design Patent**  
**Morris**

(10) **Patent No.:** **US D672,114 S**  
(45) **Date of Patent:** **\*\* Dec. 4, 2012**

(54) **HOIST LINK FOR A DRAGLINE ASSEMBLY**

(75) Inventor: **Joash Rex Morris**, Merewether (AU)

(73) Assignee: **Bradken Resources PTY Limited**,  
Mayfield West, NSW (AU)

(\*\*) Term: **14 Years**

(21) Appl. No.: **29/414,204**

(22) Filed: **Feb. 27, 2012**

(51) **LOC (9) Cl.** ..... **12-05**

(52) **U.S. Cl.** ..... **D34/35**

(58) **Field of Classification Search** ..... D34/29,  
D34/35; D8/499; 198/851, 837, 838, 850,  
198/853; 52/800.12

See application file for complete search history.

(56) **References Cited**

**U.S. PATENT DOCUMENTS**

2,911,091	A *	11/1959	Imse	.....	198/853
3,442,076	A *	5/1969	Marzo	.....	59/90
3,868,011	A *	2/1975	Janzen et al.	.....	198/853
D289,607	S *	5/1987	Schroeder et al.	.....	D34/29
4,676,368	A *	6/1987	Damkjar	.....	198/852
D291,777	S *	9/1987	Lapeyre et al.	.....	D34/29
D332,213	S *	1/1993	Woyach et al.	.....	D8/499

D340,564	S *	10/1993	Ledingham	.....	D34/29
5,797,820	A *	8/1998	Endo	.....	474/230
D473,032	S *	4/2003	Altom	.....	D34/29
D486,289	S *	2/2004	Abbestam	.....	D34/29
6,978,885	B1 *	12/2005	Schumacher	.....	198/851
7,097,032	B2 *	8/2006	Hartman et al.	.....	198/853
D655,882	S *	3/2012	Franzaroli	.....	D34/29
2008/0017482	A1 *	1/2008	Fandella	.....	198/851

\* cited by examiner

*Primary Examiner* — Cynthia Ramirez

(74) *Attorney, Agent, or Firm* — Sunstein Kann Murphy & Timbers LLP

(57) **CLAIM**

The ornamental design for a hoist link for a dragline assembly, as shown and described.

**DESCRIPTION**

FIG. 1 shows an elevated top view of a hoist link for a dragline assembly according to a preferred embodiment.

FIG. 2 shows a top plan view of the assembly of FIG. 1.

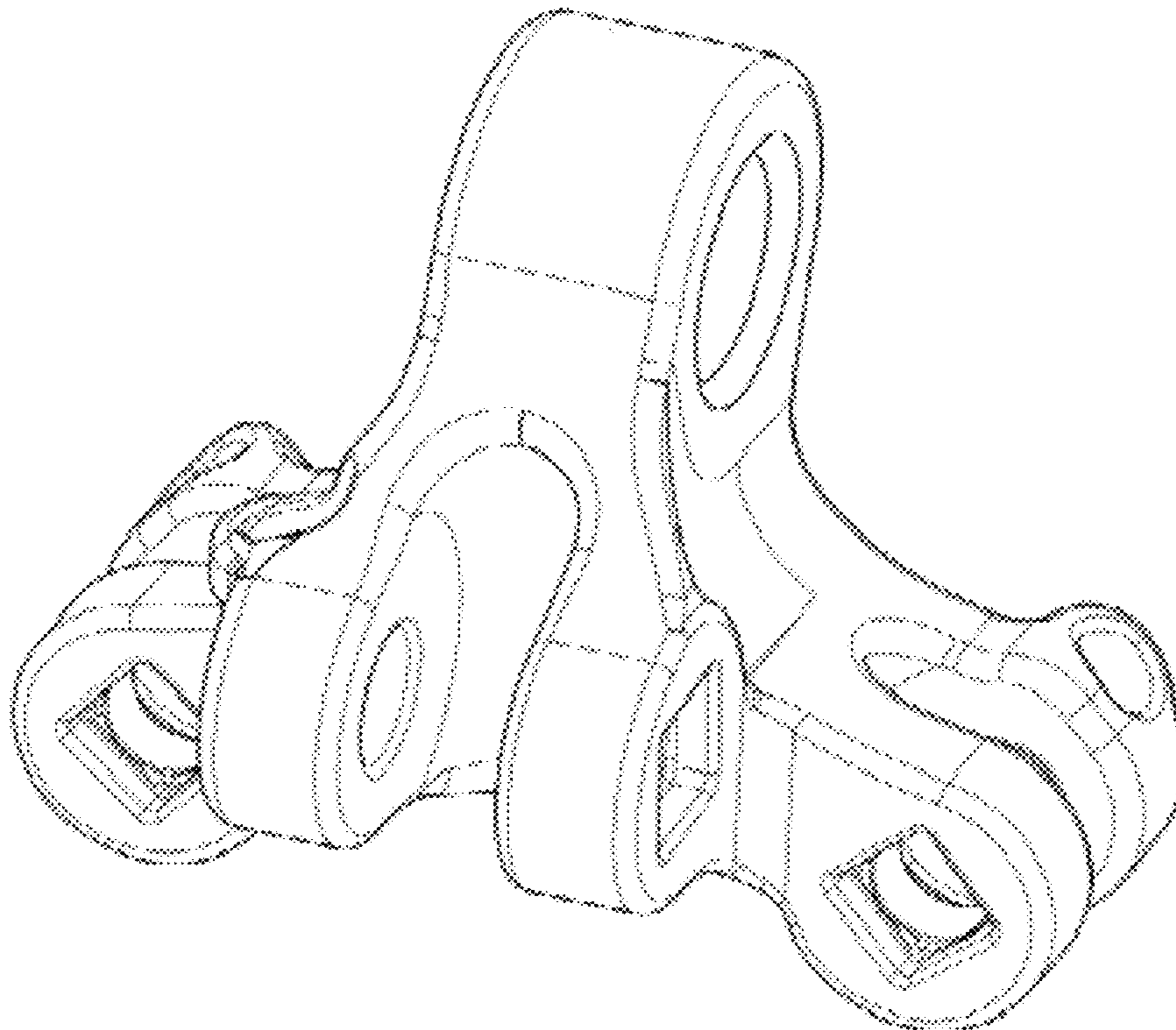
FIG. 3 shows a bottom plan view of the assembly of FIG. 1.

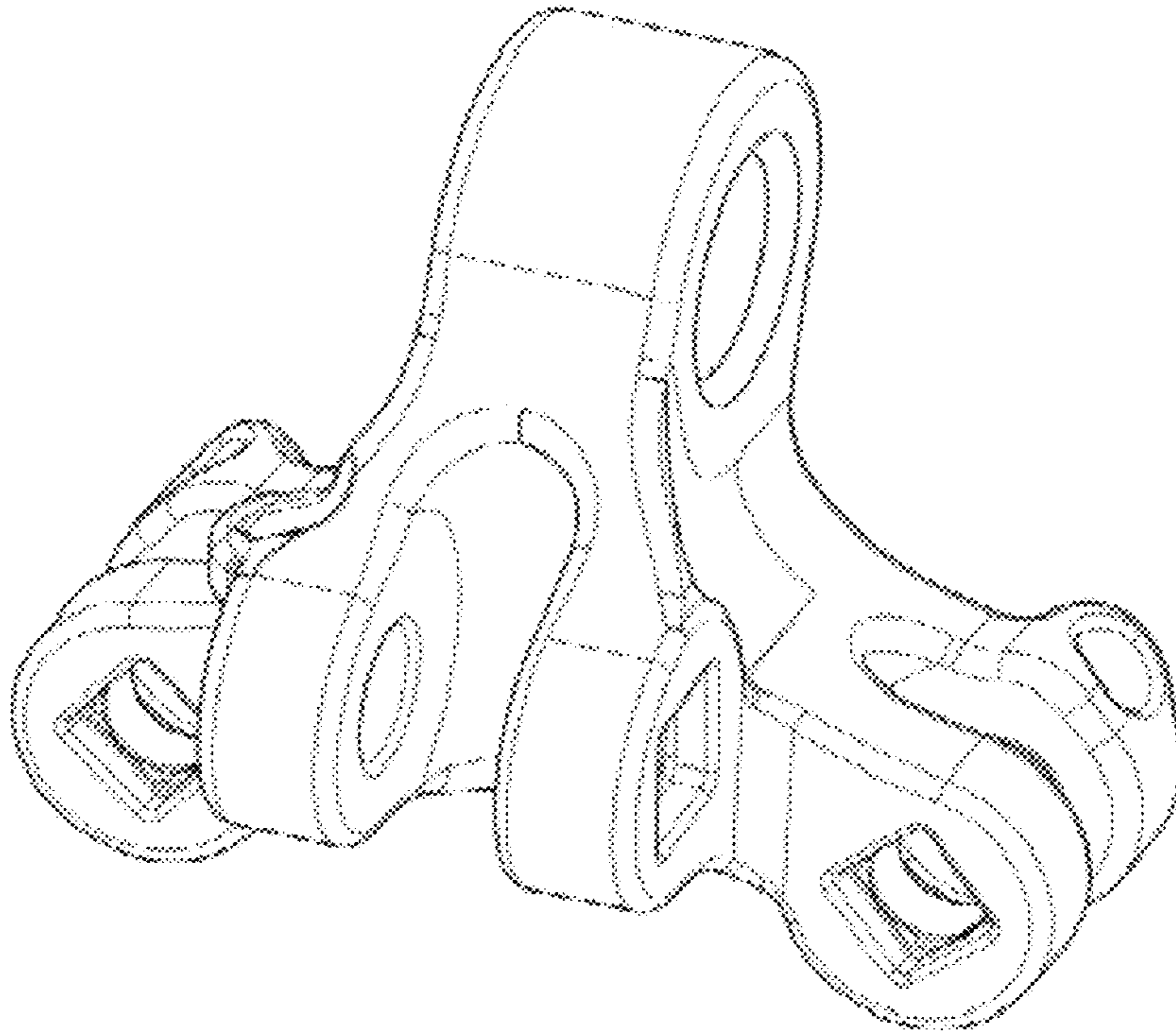
FIG. 4 shows a front side view of the assembly of FIG. 1.

FIG. 5 shows a left side view of the assembly of FIG. 1; and,

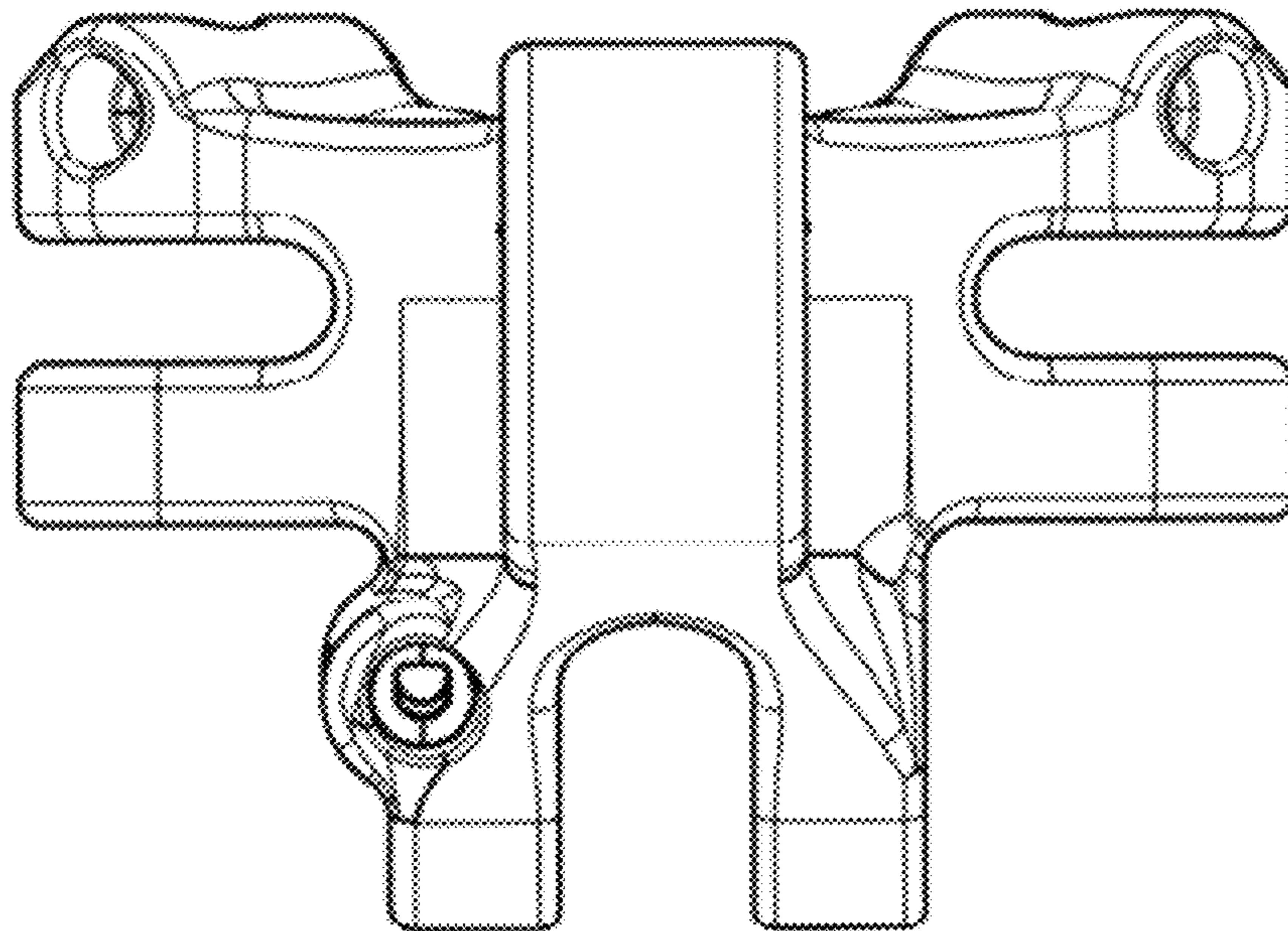
FIG. 6 shows a right side view of the assembly of FIG. 1.

**1 Claim, 3 Drawing Sheets**



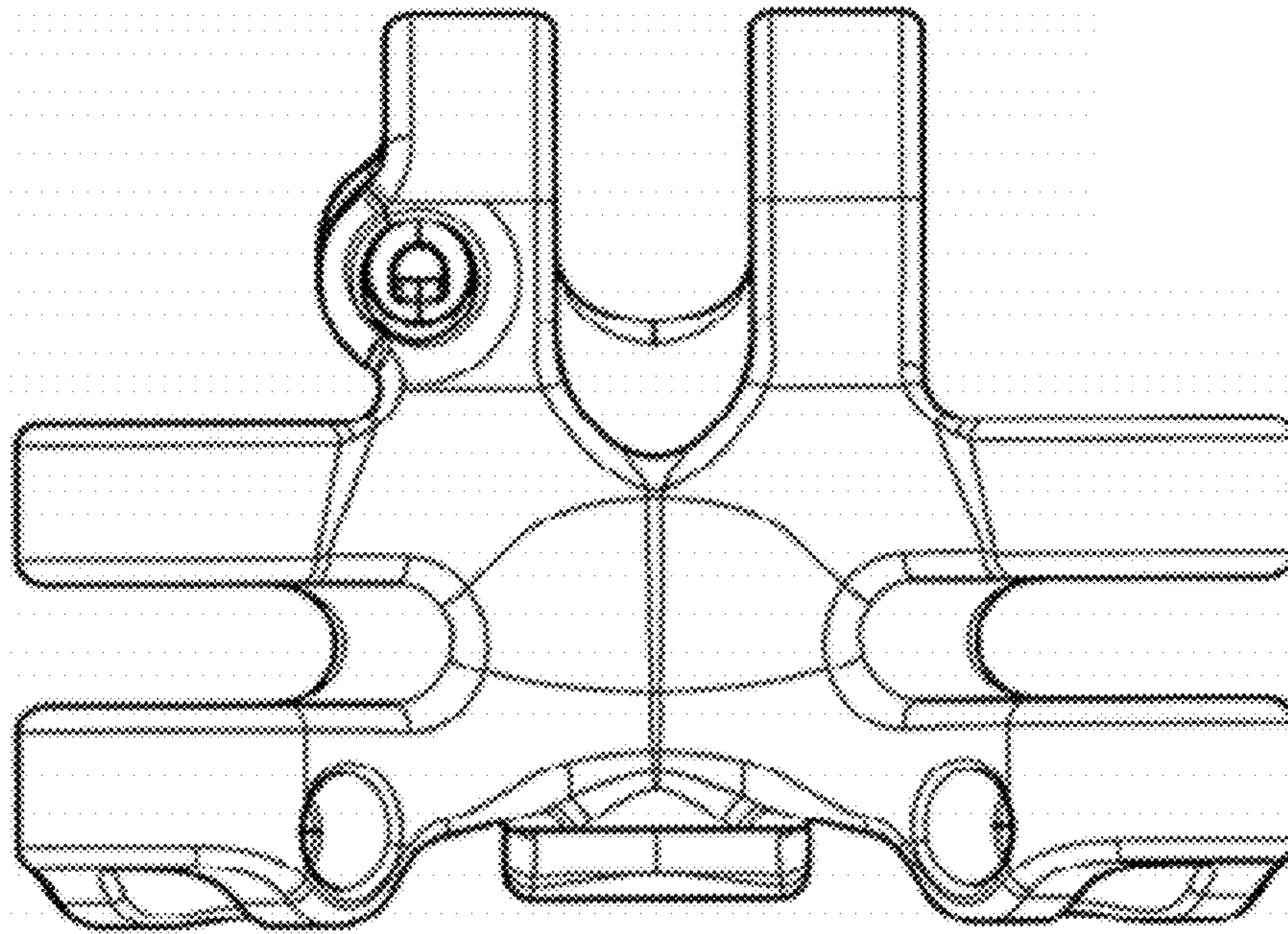


**Fig. 1**

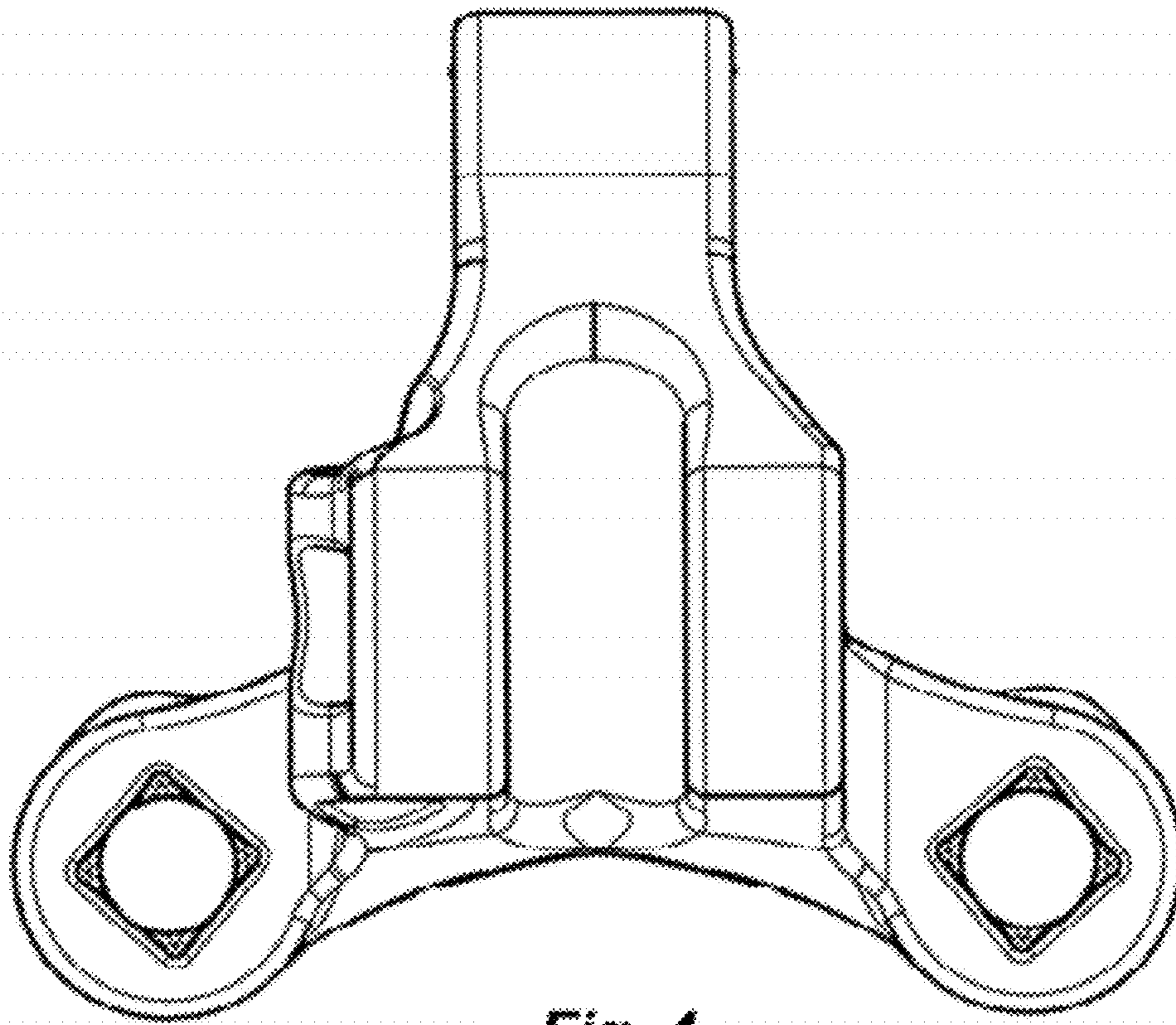


**Fig. 2**

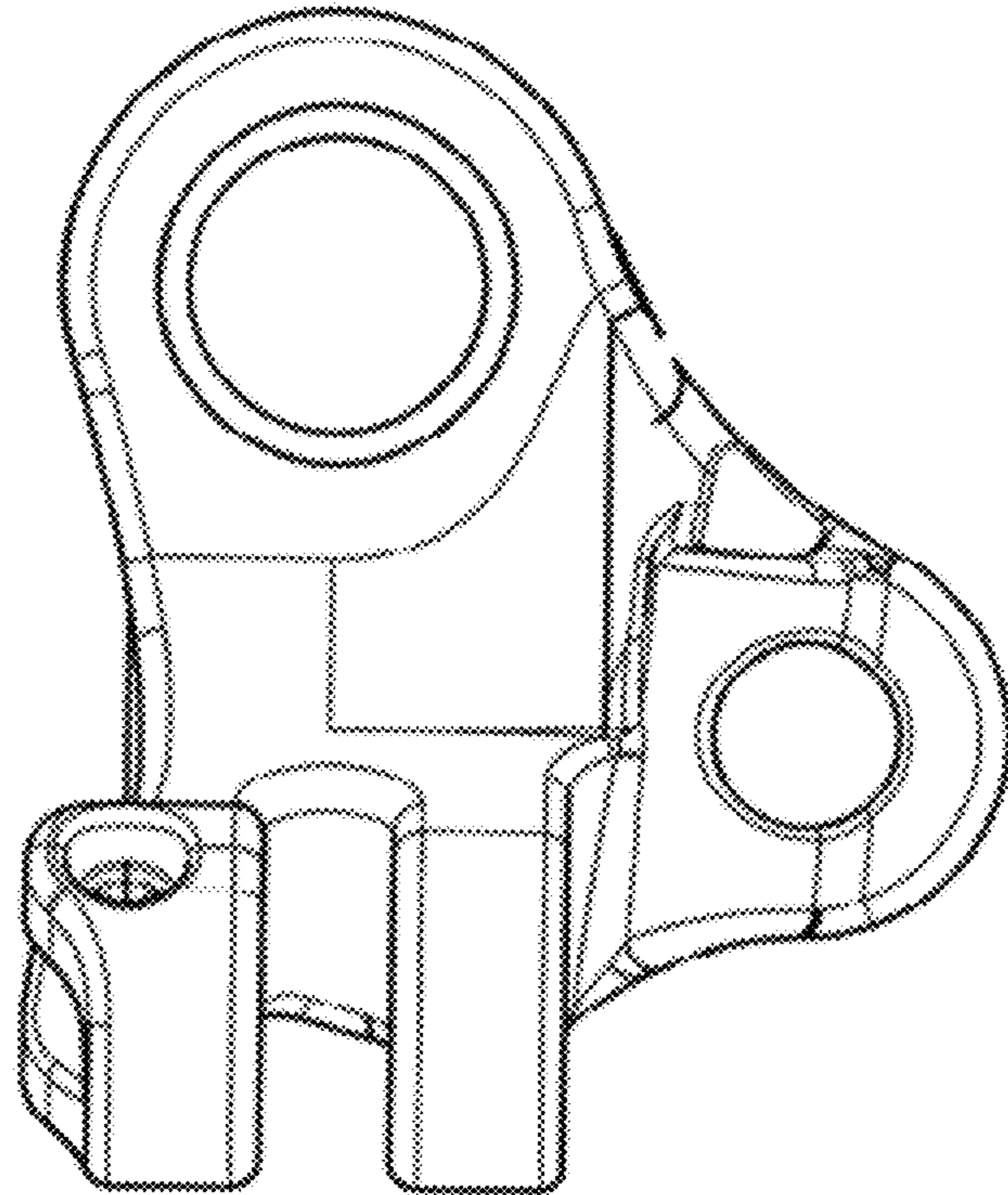




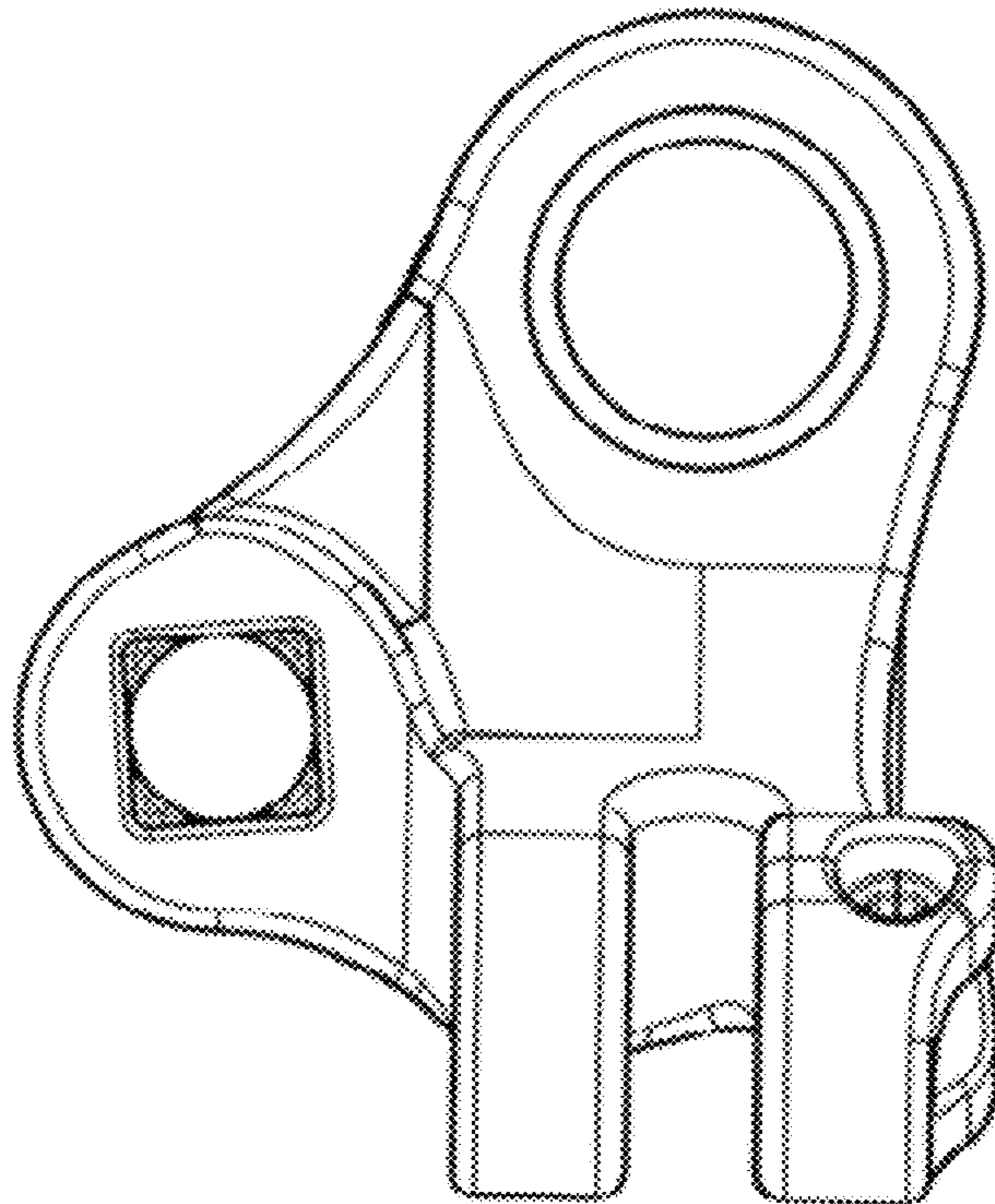
**Fig. 3**



**Fig. 4**



**Fig. 5**



**Fig. 6**