



US00D671960S

(12) **United States Design Patent**  
**Kirk et al.**

(10) **Patent No.:** **US D671,960 S**

(45) **Date of Patent:** **\*\* Dec. 4, 2012**

(54) **CENTRALISER**

(75) Inventors: **Andrew Keith Kirk**, Methlick (GB);  
**Ian Alastair Kirk**, Aberdeen (GB)

(73) Assignee: **Downhole Products Limited**, Aberdeen  
(GB)

(\*\*) Term: **14 Years**

(21) Appl. No.: **29/423,094**

(22) Filed: **May 29, 2012**

**Related U.S. Application Data**

(62) Division of application No. 29/400,032, filed on Aug.  
23, 2011, now Pat. No. Des. 662,952.

(30) **Foreign Application Priority Data**

Feb. 24, 2011 (EM) ..... 001825977

(51) **LOC (9) Cl.** ..... **15-03**

(52) **U.S. Cl.** ..... **D15/21**

(58) **Field of Classification Search** ..... D15/10,  
D15/21; 166/384, 241.1-241.7, 213, 173,  
166/208, 382; 175/325.5, 325.1, 325.2, 325.3;  
138/108, 112; 228/155; 72/393

See application file for complete search history.

(56) **References Cited**

**U.S. PATENT DOCUMENTS**

2,392,145 A	1/1946	Hall	
3,119,451 A	1/1964	Hall	
3,209,836 A	10/1965	Hall, Sr.	
3,343,608 A	9/1967	Solum	
3,566,965 A	3/1971	Solum	
3,575,239 A	4/1971	Solum	
4,088,186 A	5/1978	Callihan et al.	
4,143,713 A *	3/1979	Kreft	166/241.7
4,219,081 A	8/1980	Howe	
4,255,847 A	3/1981	Howe	
4,261,556 A	4/1981	Howe	
4,363,360 A	12/1982	Richey	
4,520,869 A	6/1985	Svenson	
4,531,582 A	7/1985	Muse et al.	
4,545,436 A	10/1985	Harrison	
4,641,776 A	2/1987	Vlasek et al.	
4,651,823 A	3/1987	Spikes	

4,688,636 A	8/1987	Hennessey
4,787,458 A	11/1988	Langer
4,875,524 A	10/1989	Bradley et al.
4,909,322 A	3/1990	Patterson et al.
H1192 H	6/1993	Keller
5,238,062 A	8/1993	Reinholdt
5,575,333 A	11/1996	Lirette et al.
5,785,125 A	7/1998	Royer

(Continued)

*Primary Examiner* — Mark Goodwin

(74) *Attorney, Agent, or Firm* — Winstead PC

(57) **CLAIM**

The ornamental design for a centraliser, as shown and described.

**DESCRIPTION**

FIG. 1 is a front view of a first embodiment of a centraliser showing our new design;

FIG. 2 is a rear view thereof;

FIG. 3 is a left side view thereof;

FIG. 4 is a right side view thereof;

FIG. 5 is a top plan view thereof;

FIG. 6 is a bottom plan view thereof;

FIG. 7 is bottom perspective view thereof;

FIG. 8 is a top perspective view thereof;

FIG. 9 is an enlarged partial top perspective view thereof;

FIG. 10 is an enlarged partial bottom perspective view thereof;

FIG. 11 is a front view of a second embodiment of the centraliser showing our new design;

FIG. 12 is a rear view thereof;

FIG. 13 is a left side view thereof;

FIG. 14 is a right side view thereof;

FIG. 15 is a top plan view thereof;

FIG. 16 is a bottom plan view thereof;

FIG. 17 is a bottom perspective view thereof;

FIG. 18 is a top perspective view thereof;

FIG. 19 is an enlarged partial top perspective view thereof; and,

FIG. 20 is an enlarged partial bottom perspective view thereof.

The broken line showing a pipe is included for the purpose of illustrating environmental structure only and the broken line showing a rectangular feature in FIGS. 9, 10, 19, and 20 represents a boundary of the enlarged portions of the claim and forms no part of the claimed design.

**1 Claim, 20 Drawing Sheets**

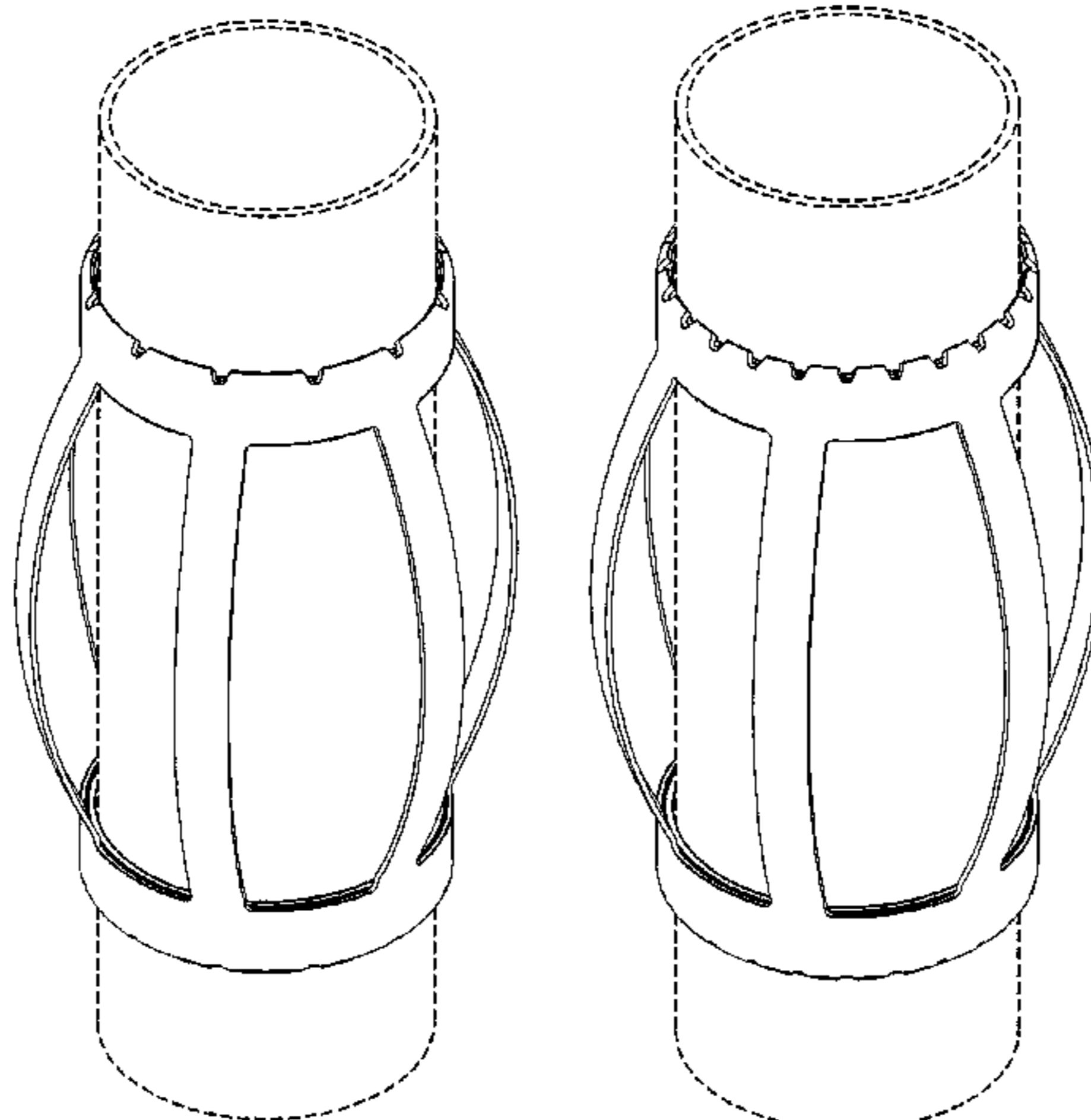

# US D671,960 S

Page 2

---

## U.S. PATENT DOCUMENTS

6,102,118	A	8/2000	Moore	6,871,706	B2	3/2005	Hennessey
6,298,883	B1	10/2001	Kinzel	7,071,697	B2	7/2006	Rioufol et al.
6,367,556	B1	4/2002	Moore	7,156,171	B2	1/2007	Gremillion
6,453,999	B1	9/2002	Reinholdt	7,182,131	B2	2/2007	Gremillion
6,457,519	B1	10/2002	Buytaert	7,849,918	B2	12/2010	Ehlinger et al.
6,484,803	B1	11/2002	Gremillion	7,878,241	B2	2/2011	Buytaert et al.
6,637,511	B2	10/2003	Linaker	2003/0230411	A1	12/2003	Richard
6,679,325	B2	1/2004	Buytaert	2009/0025929	A1	1/2009	Buytaert et al.
6,725,939	B2	4/2004	Richard				

\* cited by examiner

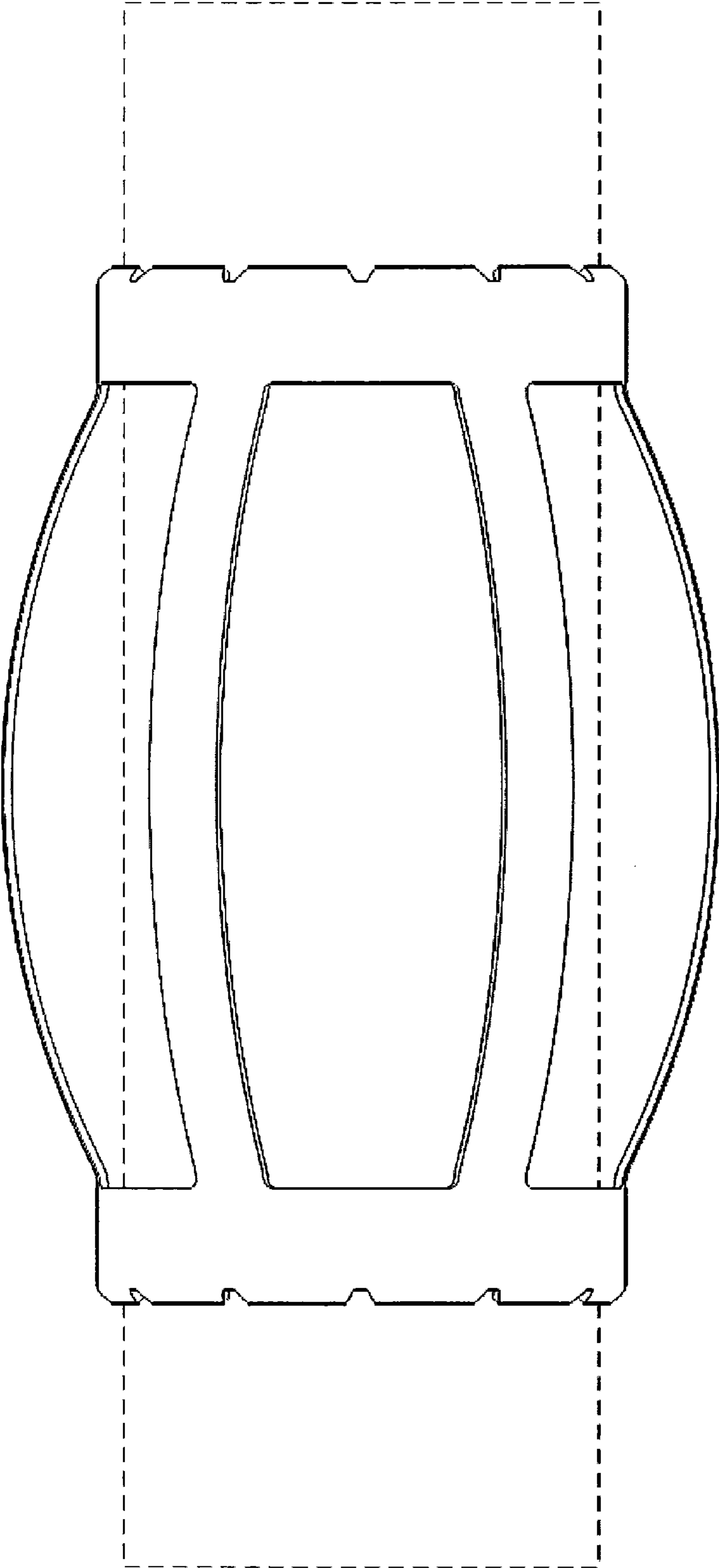

FIG. 1

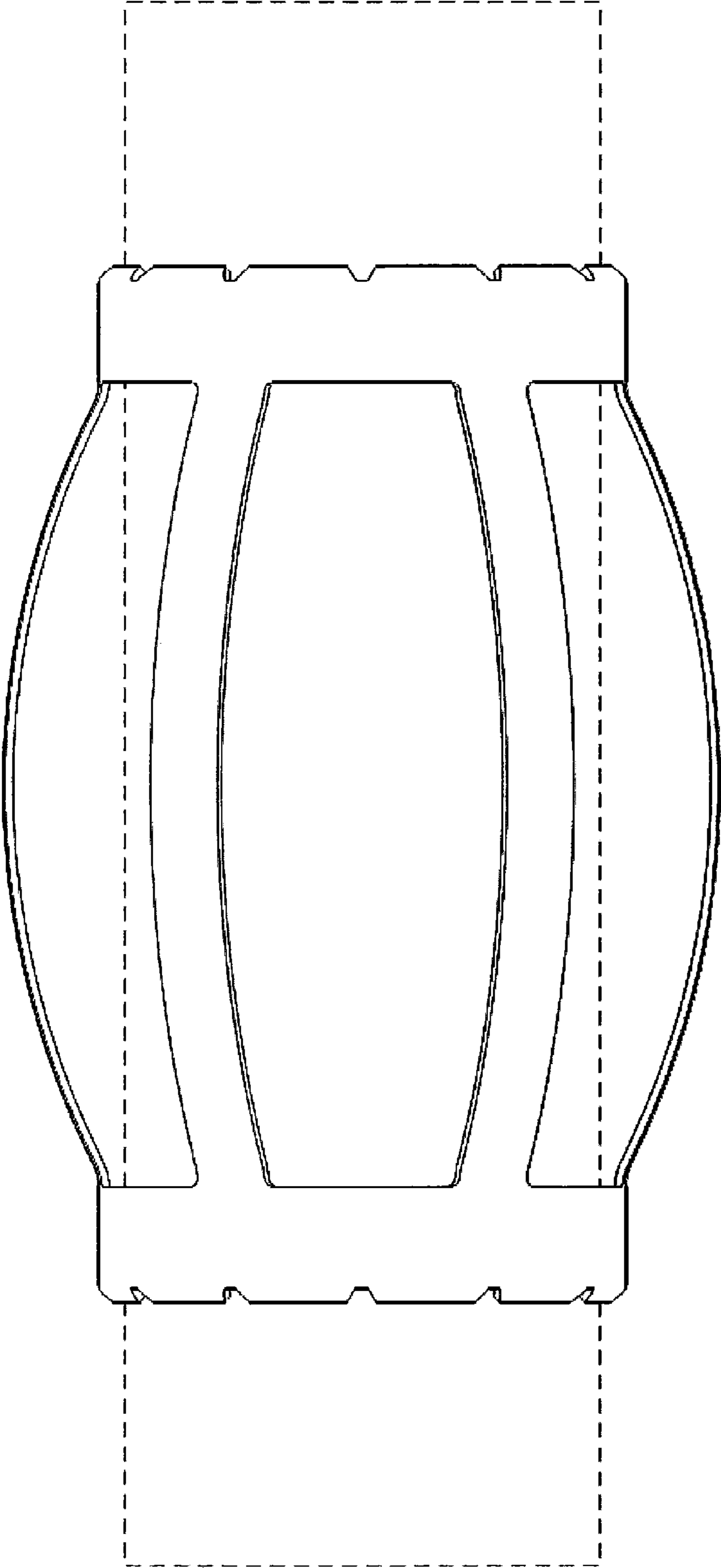

FIG. 2

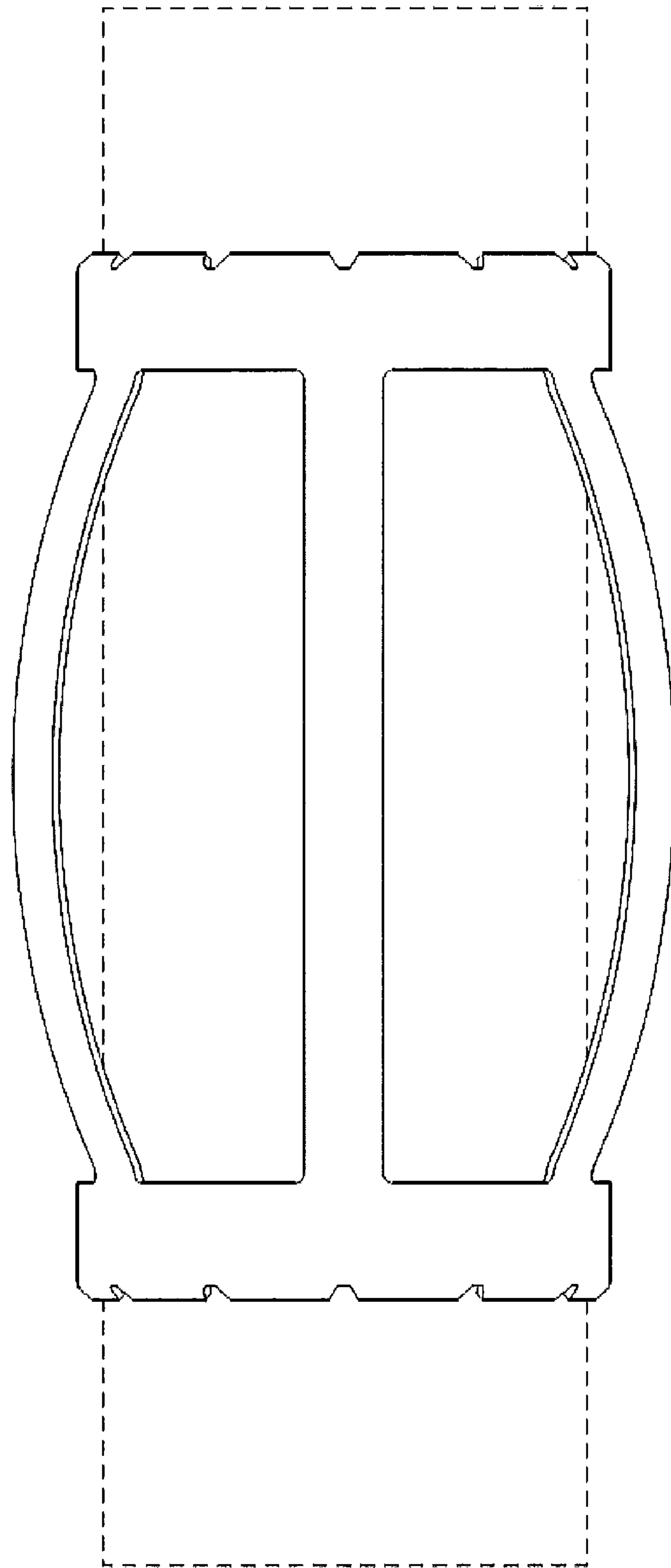

FIG. 3

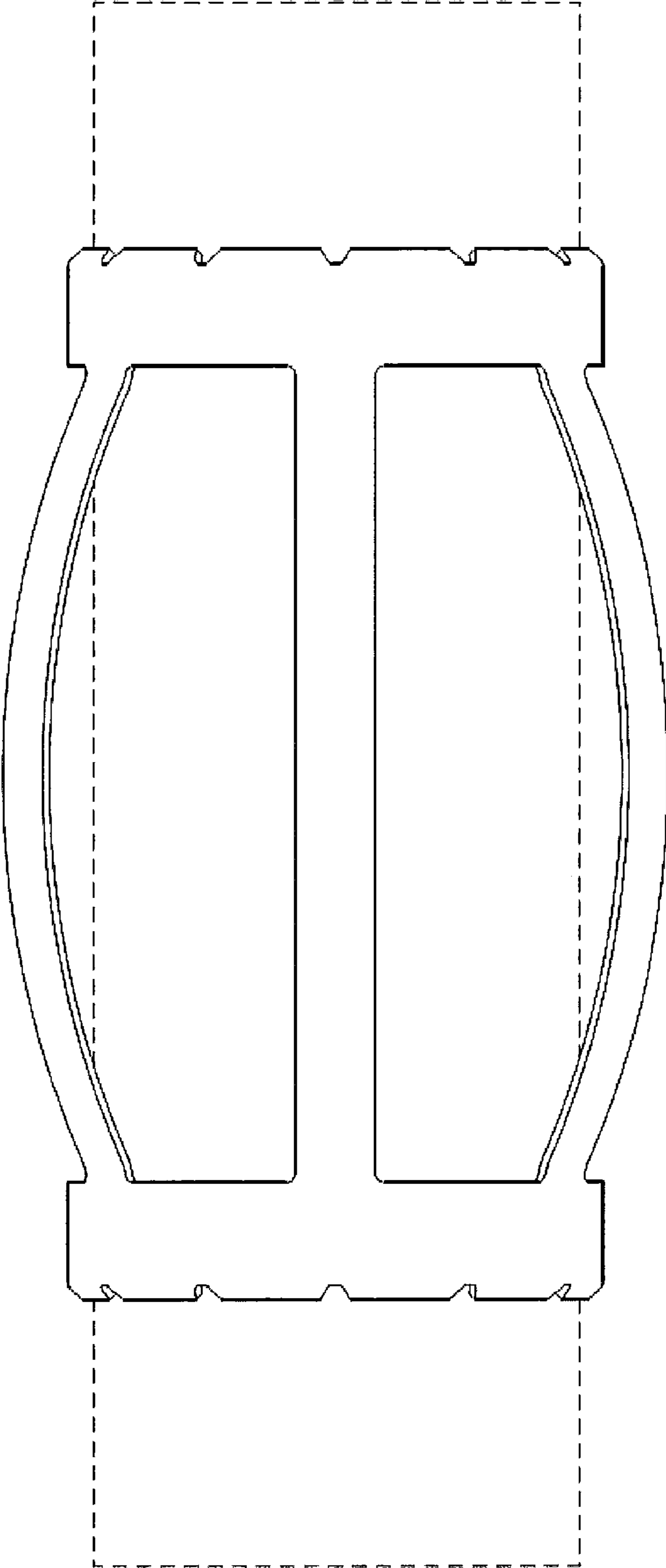

FIG. 4

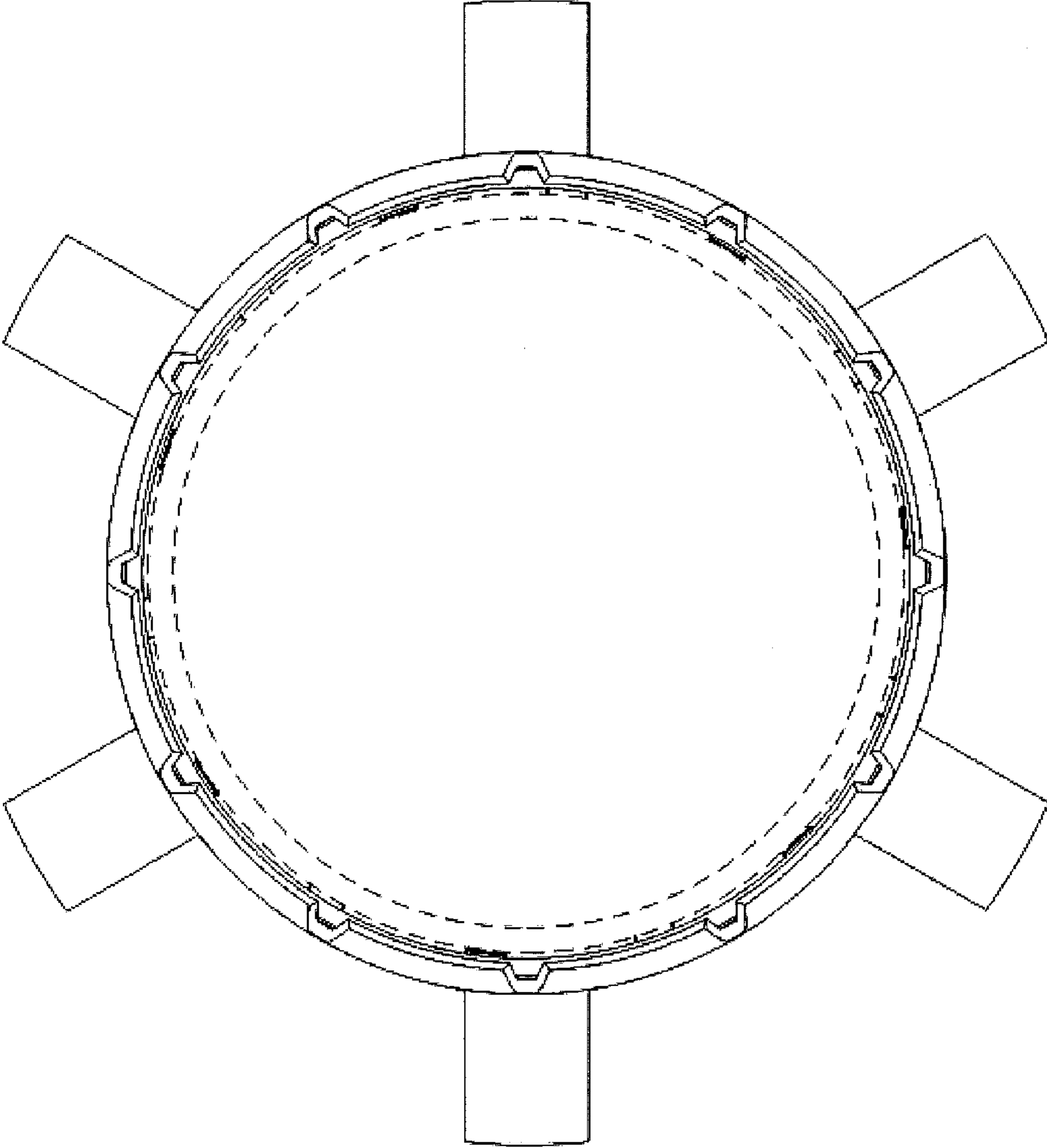

FIG. 5

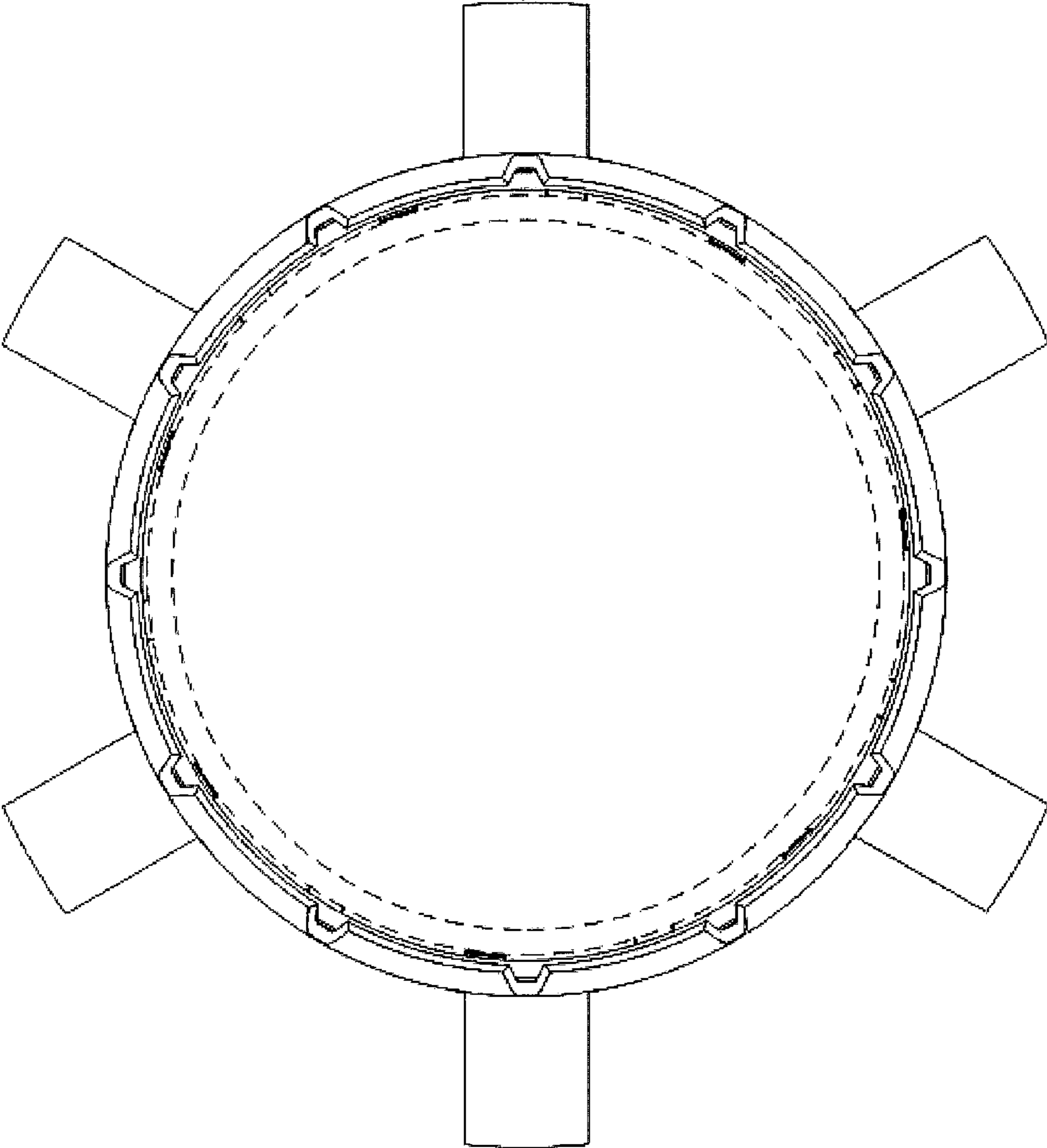

FIG. 6



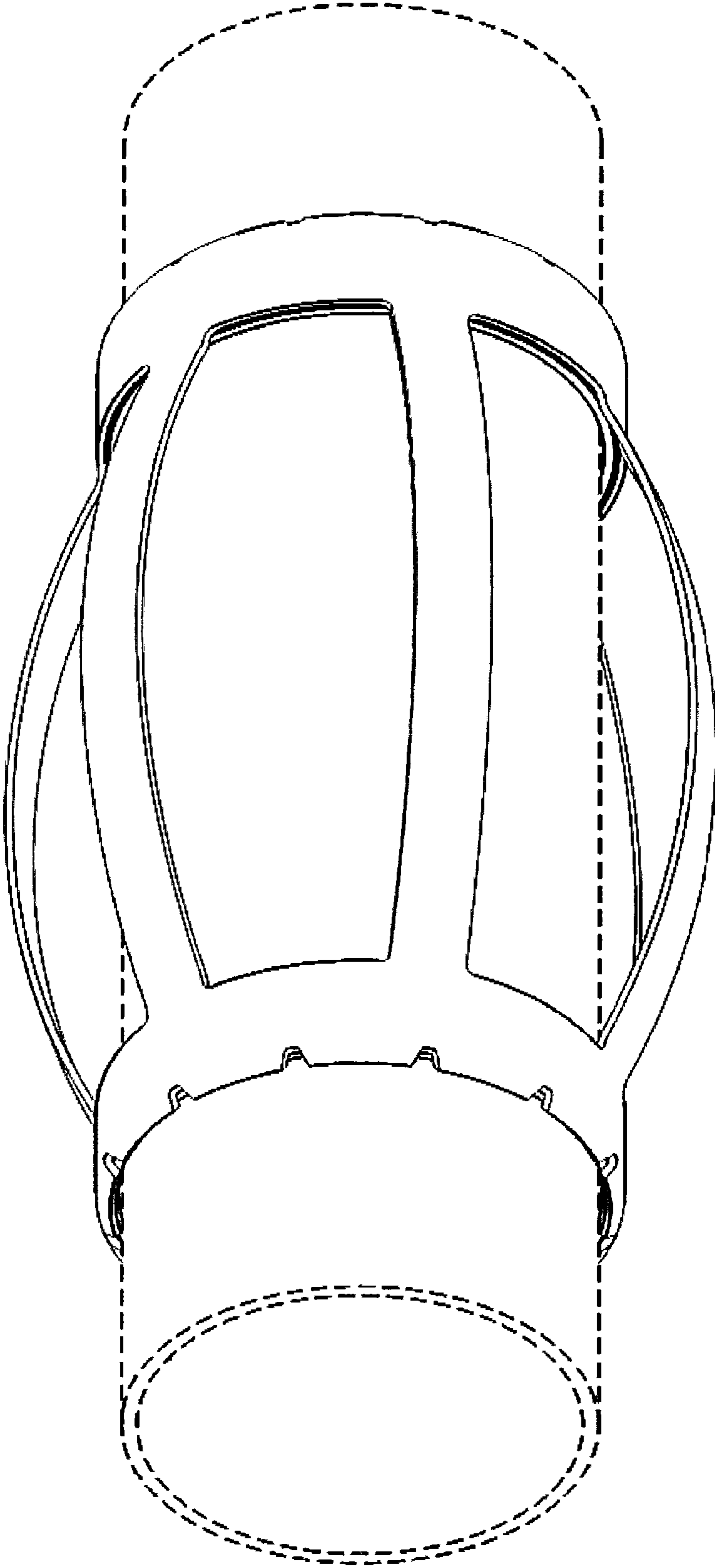

FIG. 7

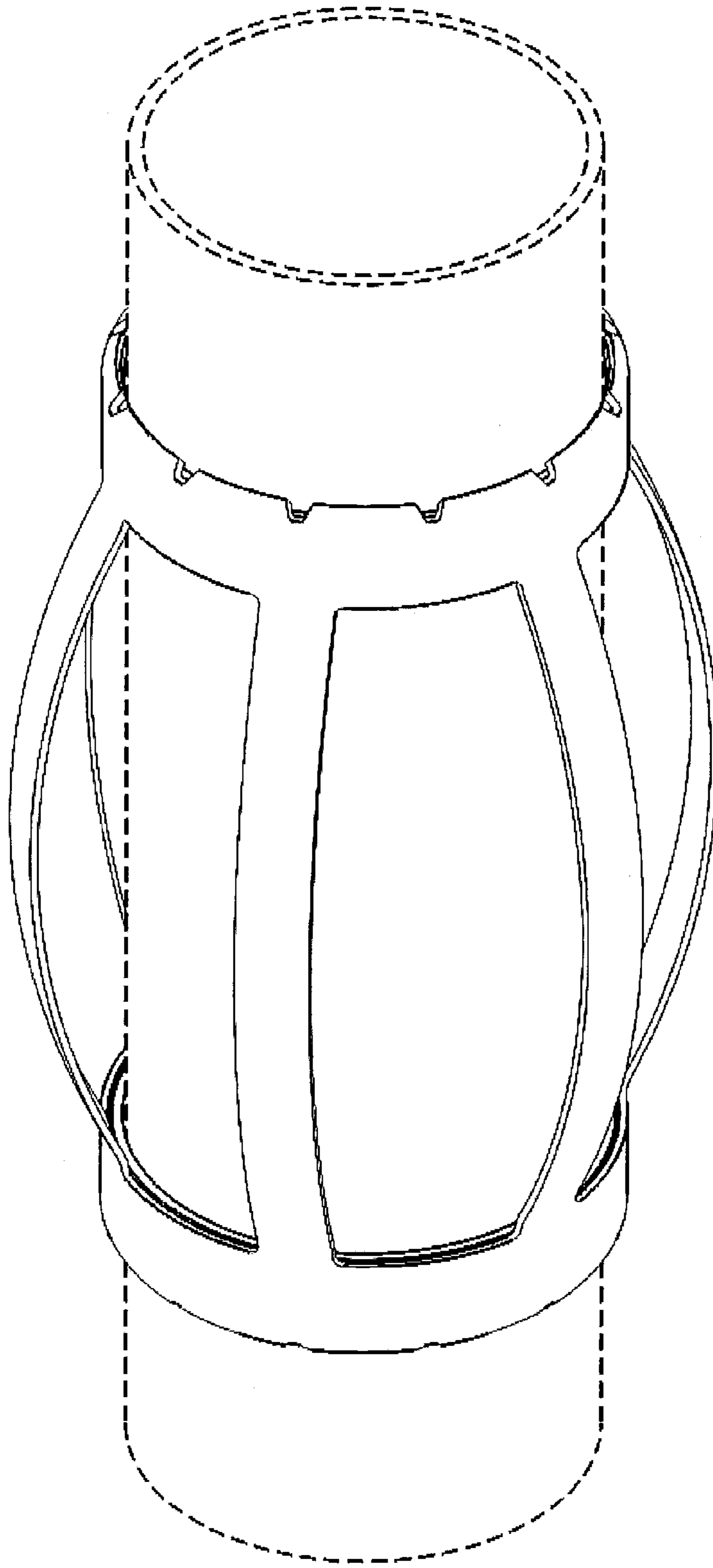

FIG. 8

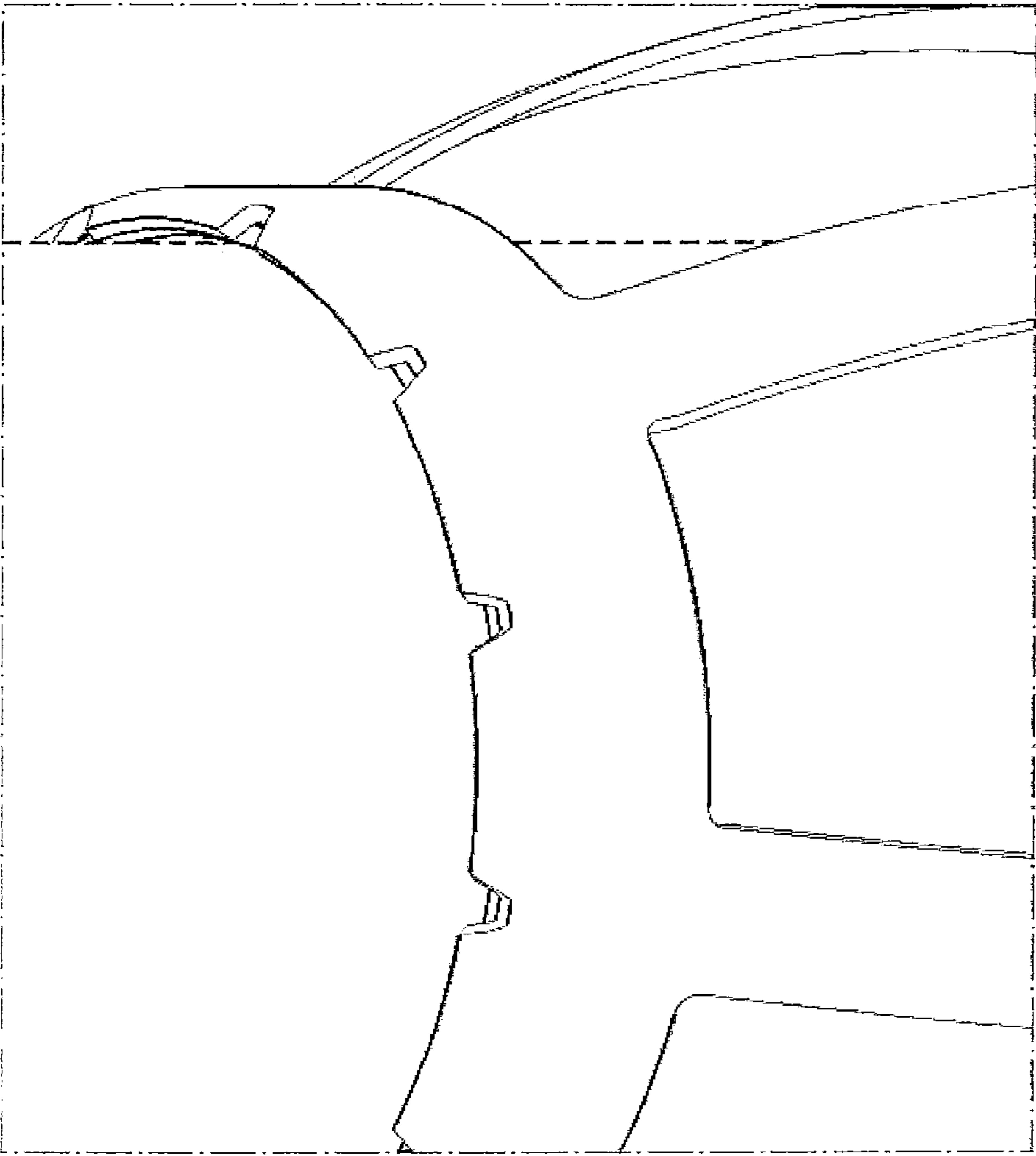

FIG. 9

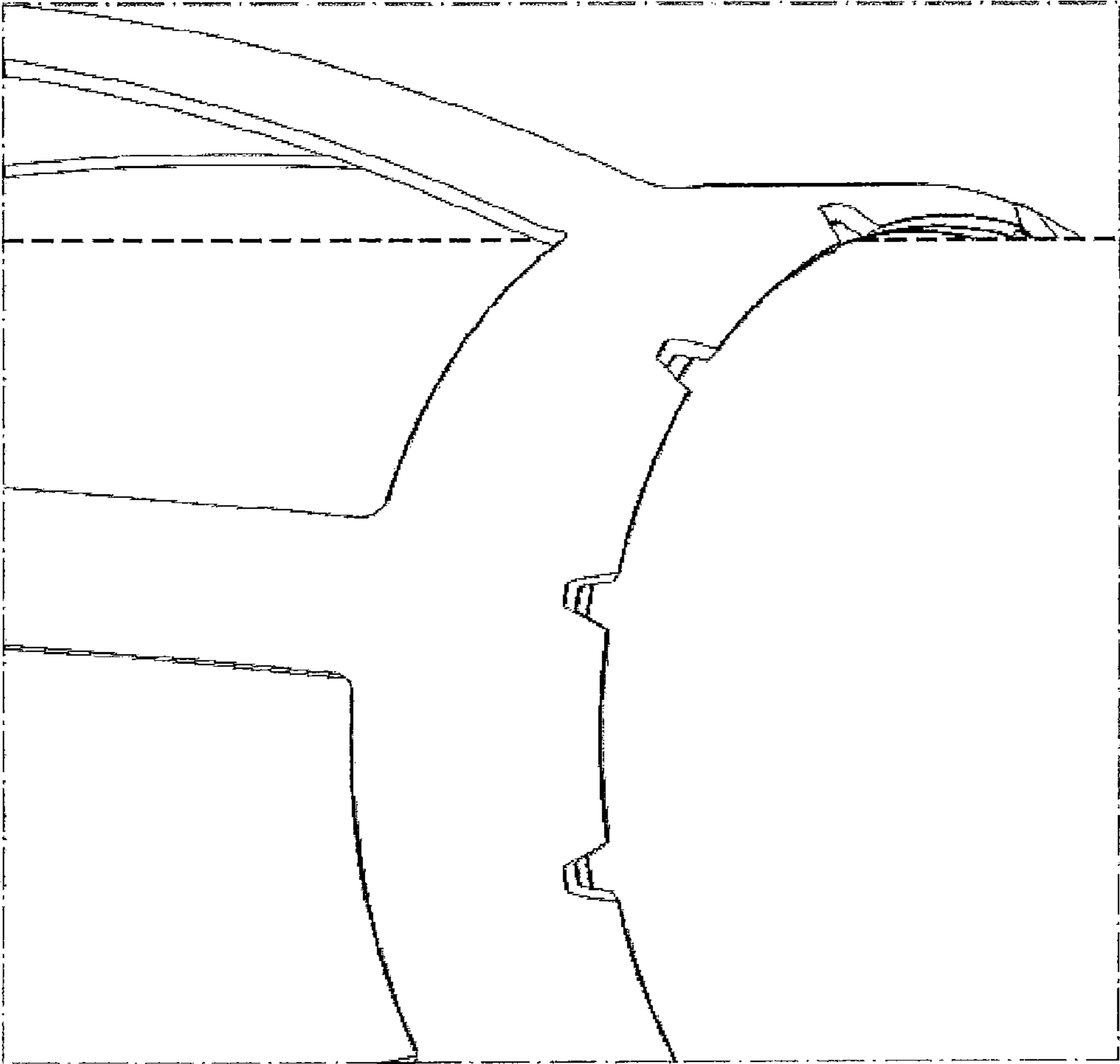

FIG. 10

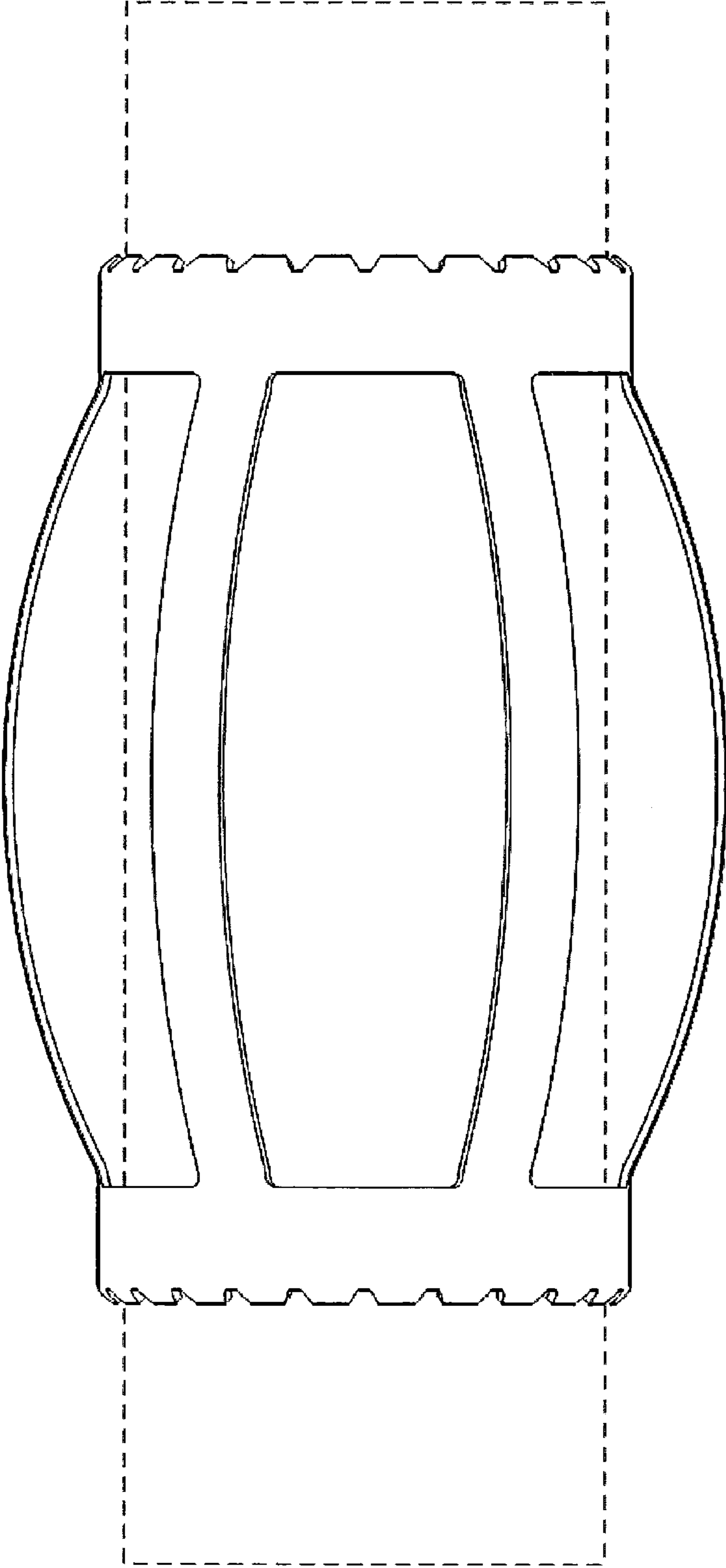

FIG. 11

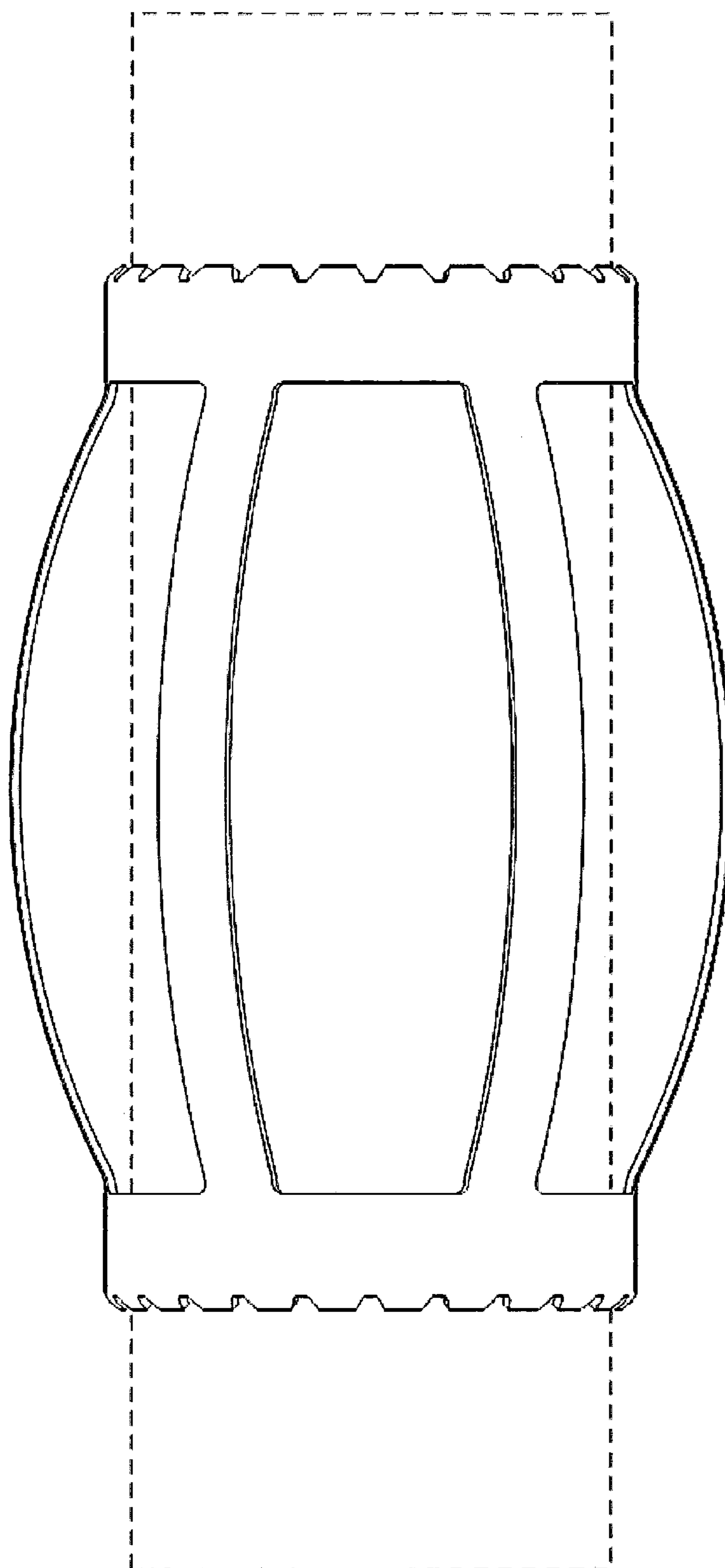

FIG. 12

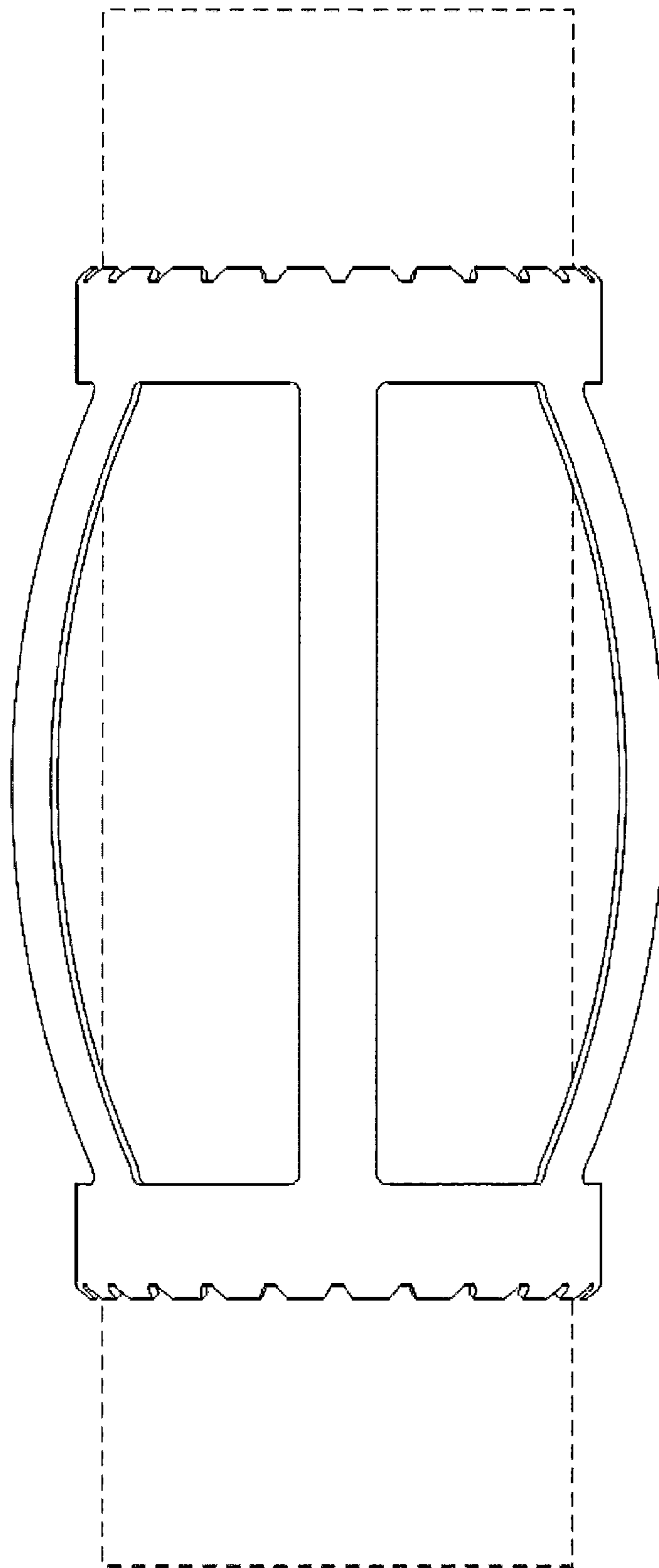

FIG. 13

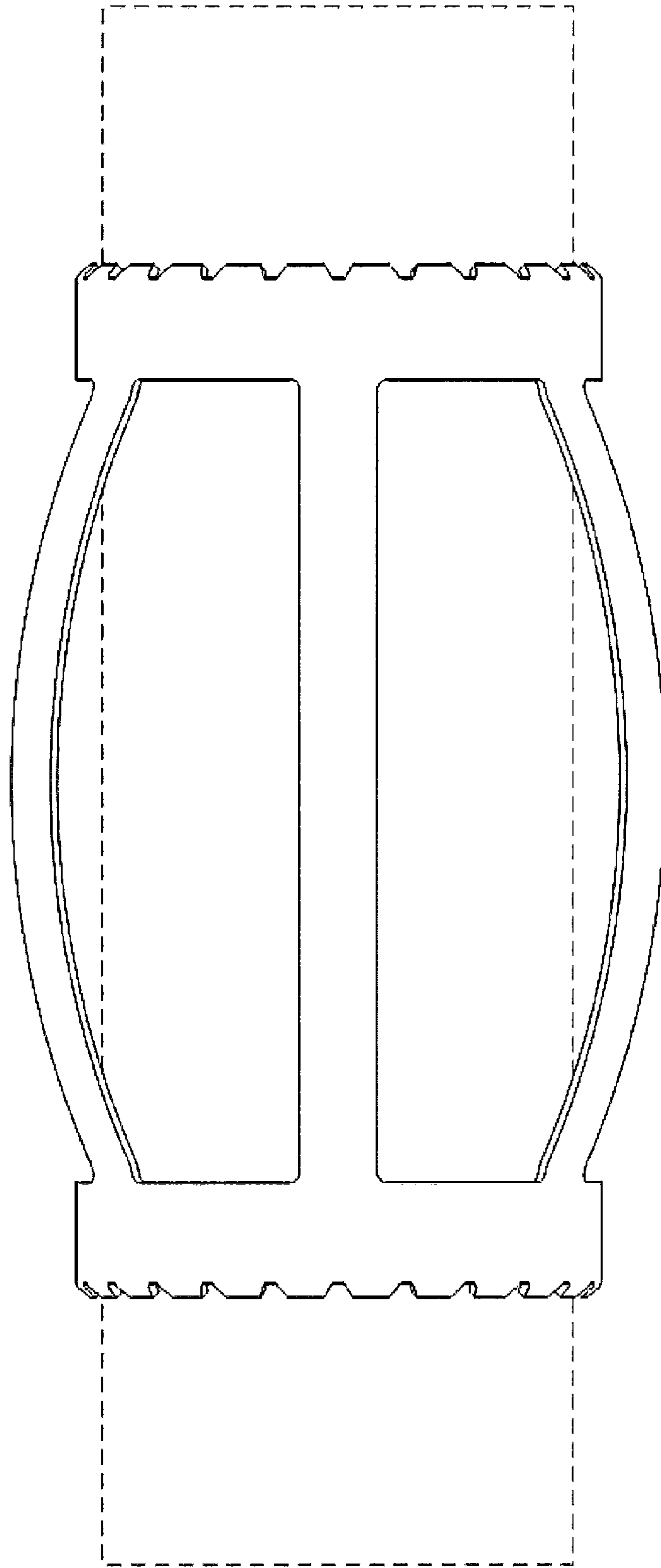

FIG. 14



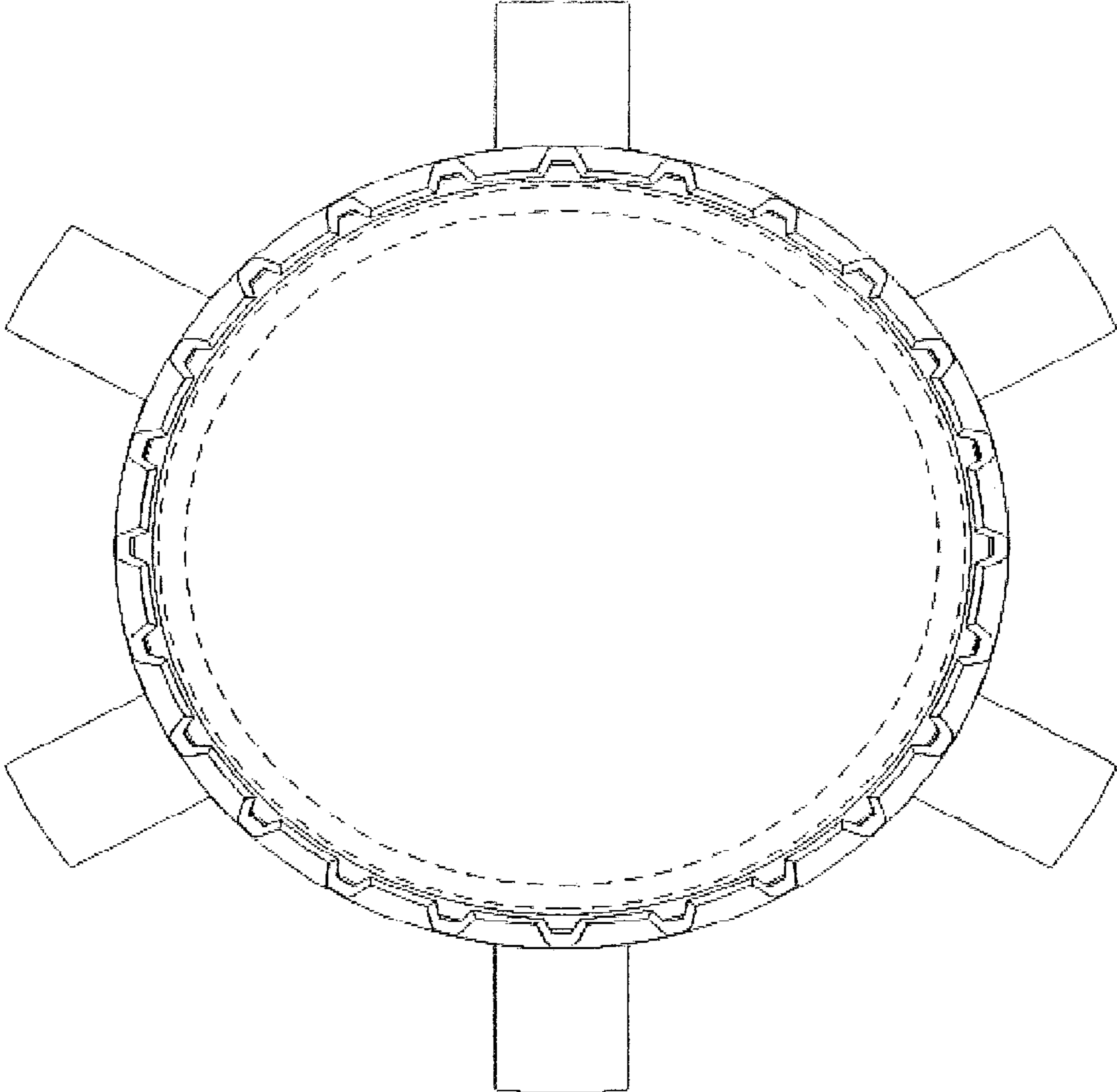

FIG. 15

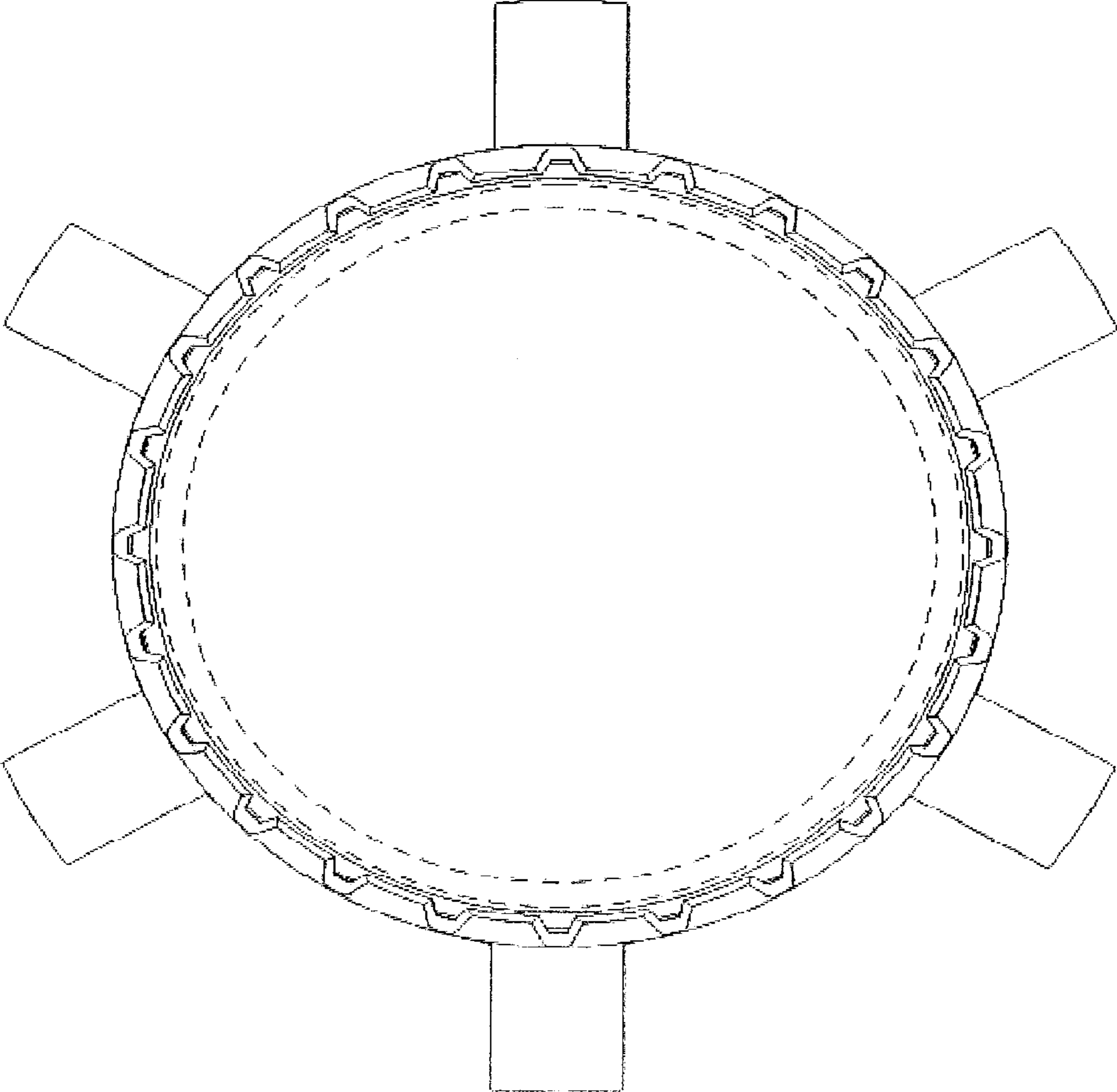

FIG. 16

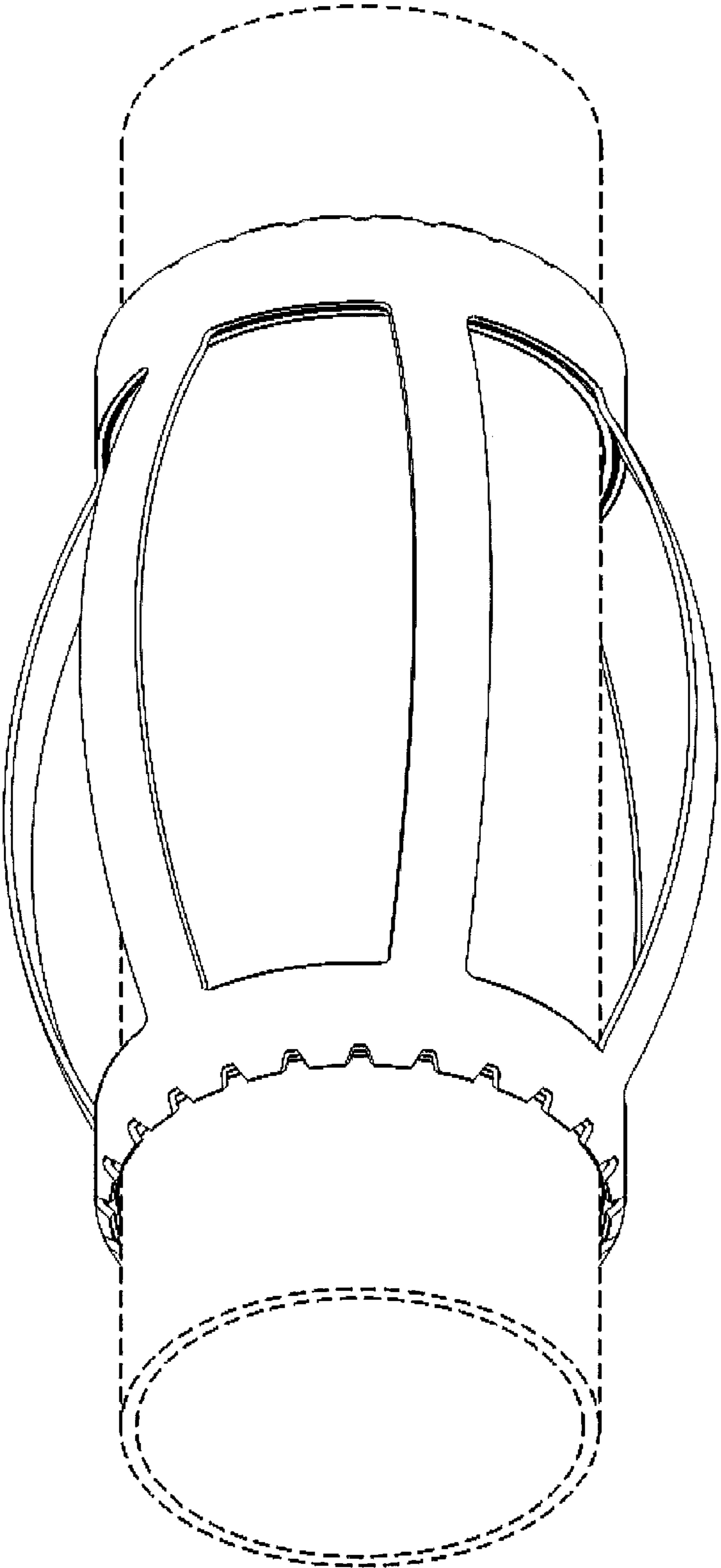

FIG. 17

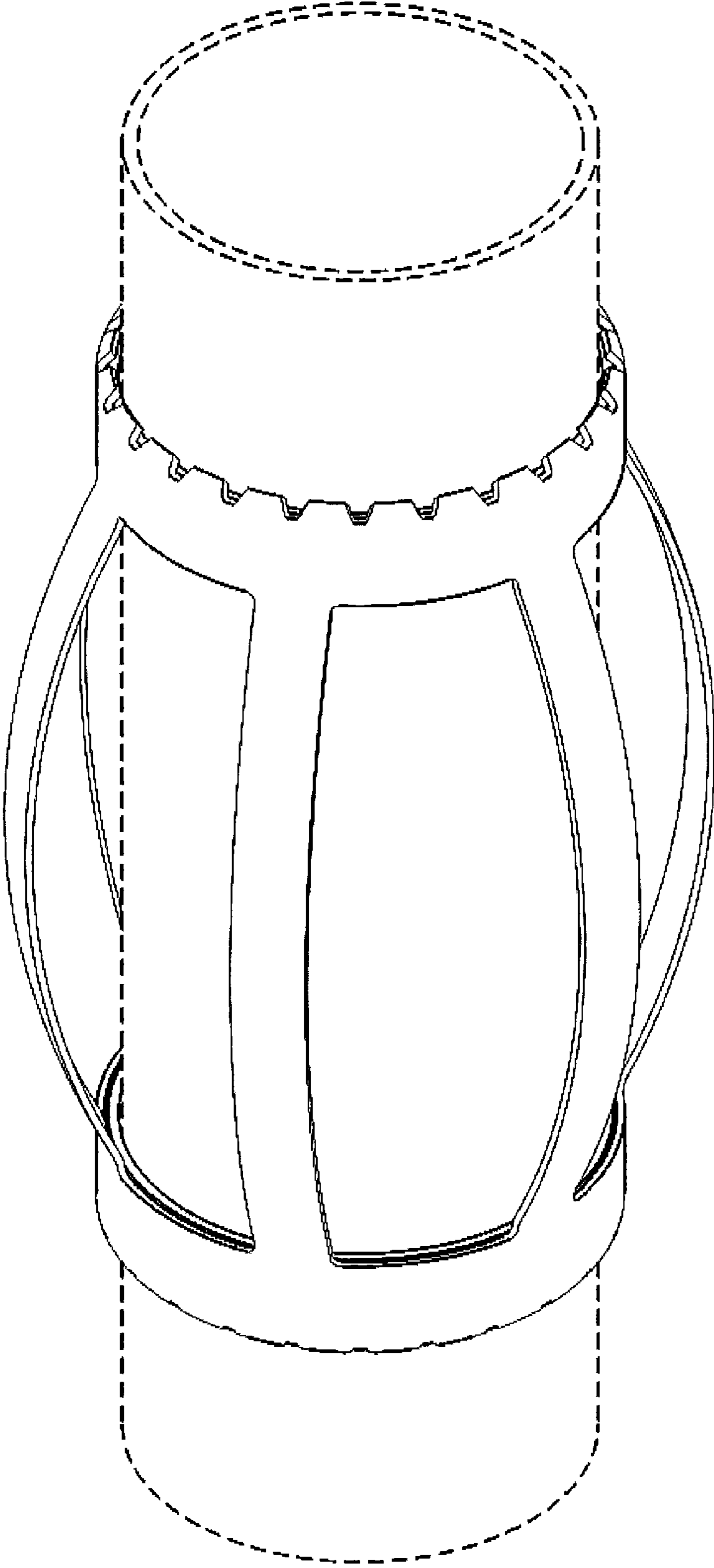

FIG. 18

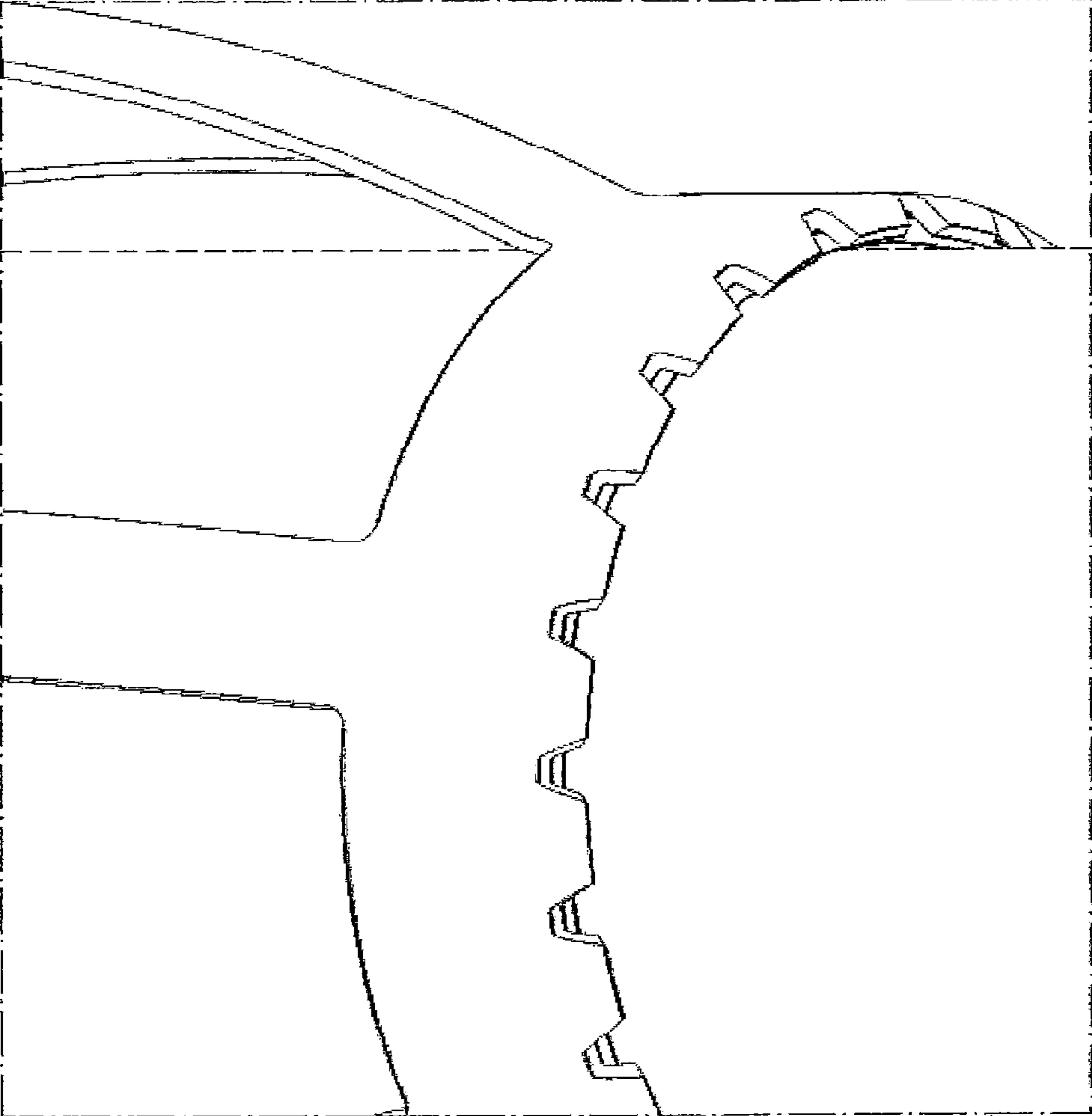

FIG. 19

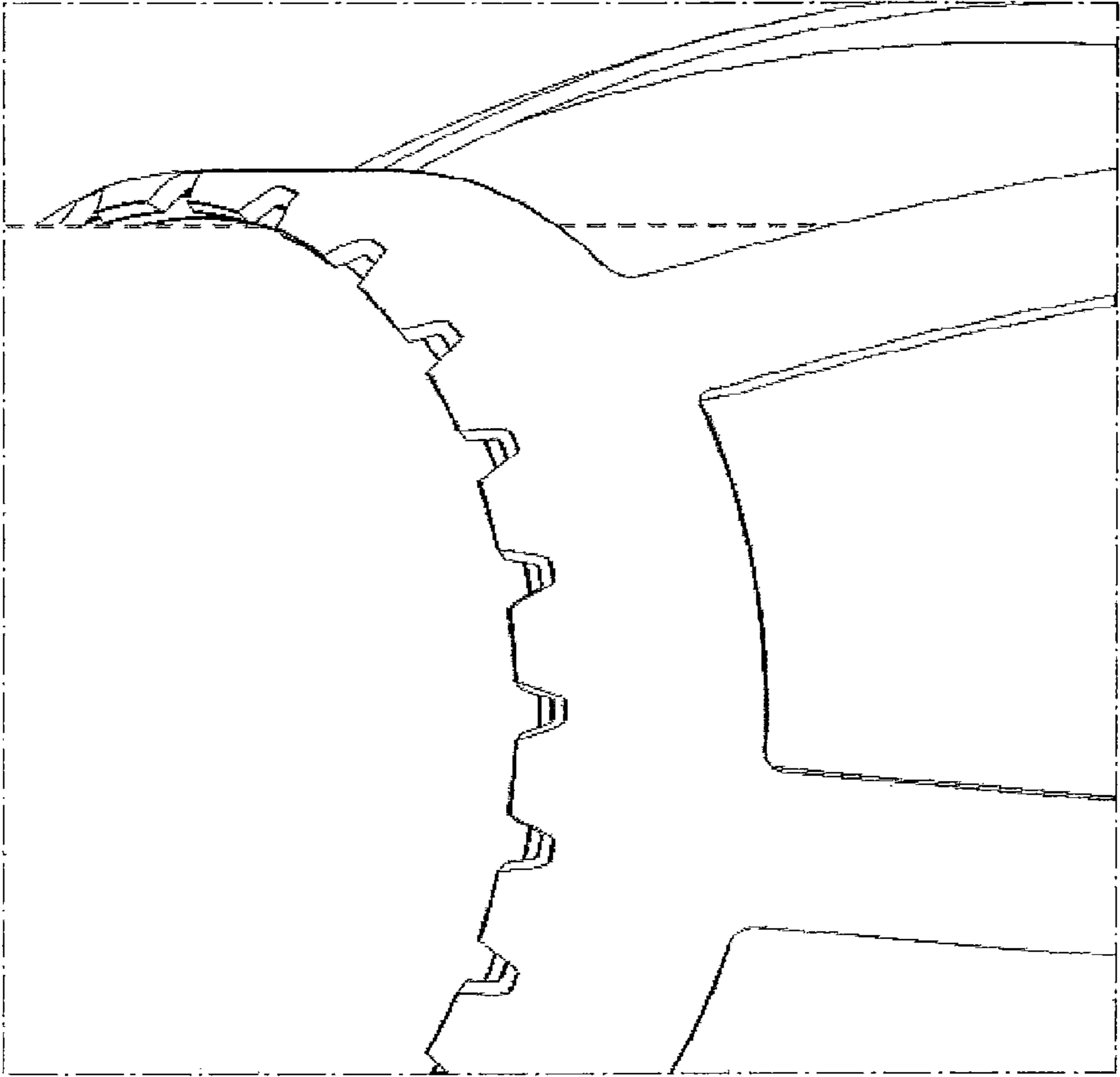

FIG. 20