



US00D671820S

(12) **United States Design Patent**
Henderson

(10) **Patent No.:** **US D671,820 S**

(45) **Date of Patent:** **** *Dec. 4, 2012**

(54) **WALL MOUNT ASSEMBLY**

(76) Inventor: **Timothy John Henderson**, Hong Kong
(CN)

(*) Notice: This patent is subject to a terminal disclaimer.

(**) Term: **14 Years**

(21) Appl. No.: **29/395,367**

(22) Filed: **Jan. 10, 2012**

(51) **LOC (9) Cl.** **08-05**

(52) **U.S. Cl.** **D8/373**

(58) **Field of Classification Search** D8/363,
D8/373; D14/451-452, 434, 253; 248/278.1,
248/284.1, 274.1, 260-261, 271-272

See application file for complete search history.

(56) **References Cited**

U.S. PATENT DOCUMENTS

847,434	A	*	3/1907	O'Brien	248/272
2,454,894	A	*	11/1948	Tatom	248/261
D272,414	S	*	1/1984	Barnes	D8/363
D596,188	S	*	7/2009	Lau et al.	D14/452
D654,503	S	*	2/2012	Sapper	D14/452

* cited by examiner

Primary Examiner — Holly Baynham

(74) *Attorney, Agent, or Firm* — William A. Jeckle

(57) **CLAIM**

I claim the ornamental design for wall mount assembly, as shown and described.

DESCRIPTION

FIG. 1 is an isometric top, front and first side view of my wall mount assembly showing my design.

FIG. 2 is an orthographic first side view thereof, with the opposite side being a mirror image.

FIG. 3 is an orthographic top, downward looking view thereof.

FIG. 4 is an orthographic bottom, upward looking view thereof.

FIG. 5 is an orthographic front view thereof.

FIG. 6 is an orthographic back view thereof.

FIG. 7 is an exploded isometric top, front and first side view similar to that of FIG. 1 showing how the components fit together; and,

FIG. 8 is a reduced in size, isometric view of my wall mount assembly in use attached to a jointed positionable arm and a tablet holder both shown in dashed outline.

The broken lines showing a positionable arm and tablet holder are for the purpose of illustrating environment and form no part of the claimed design.

1 Claim, 5 Drawing Sheets

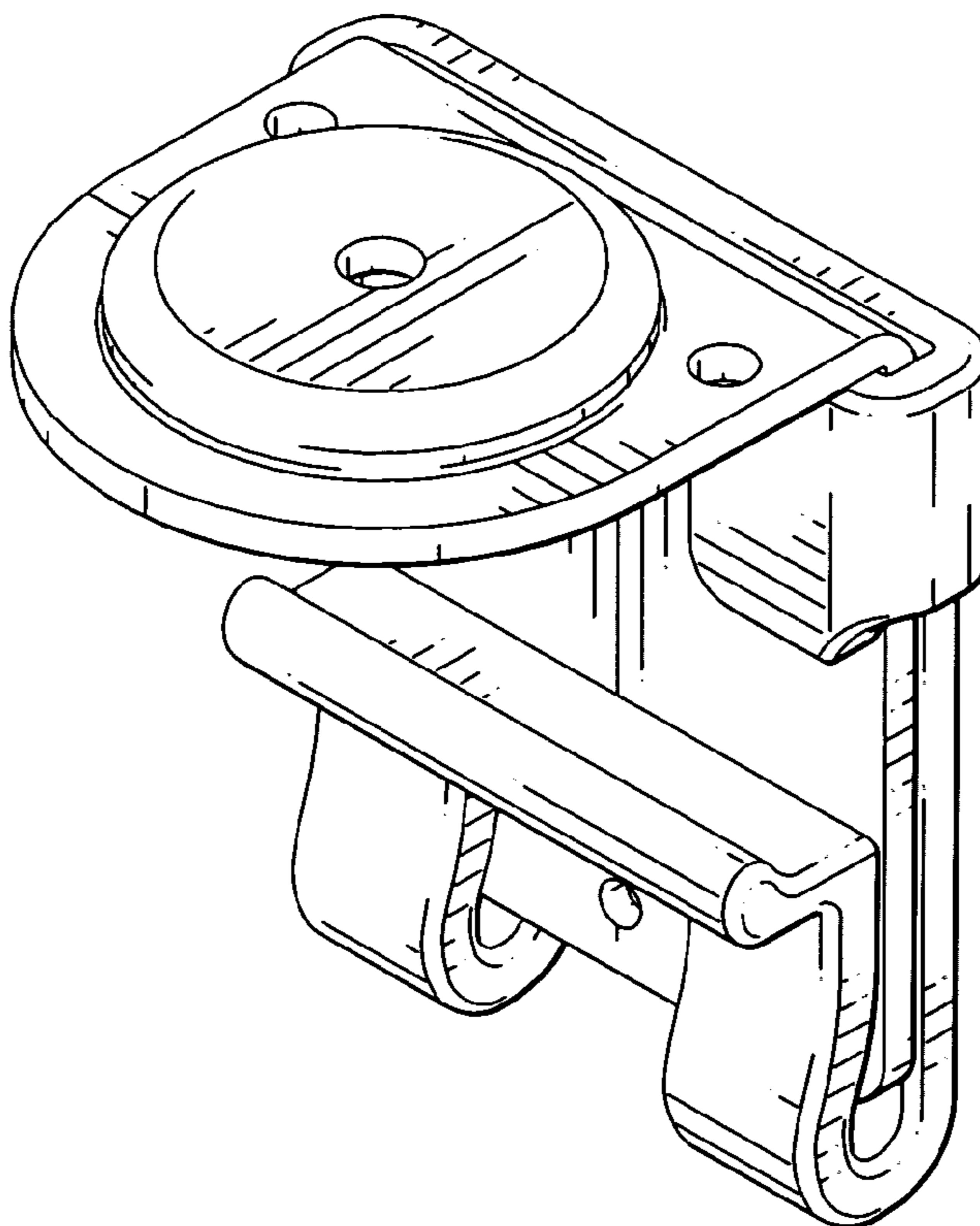

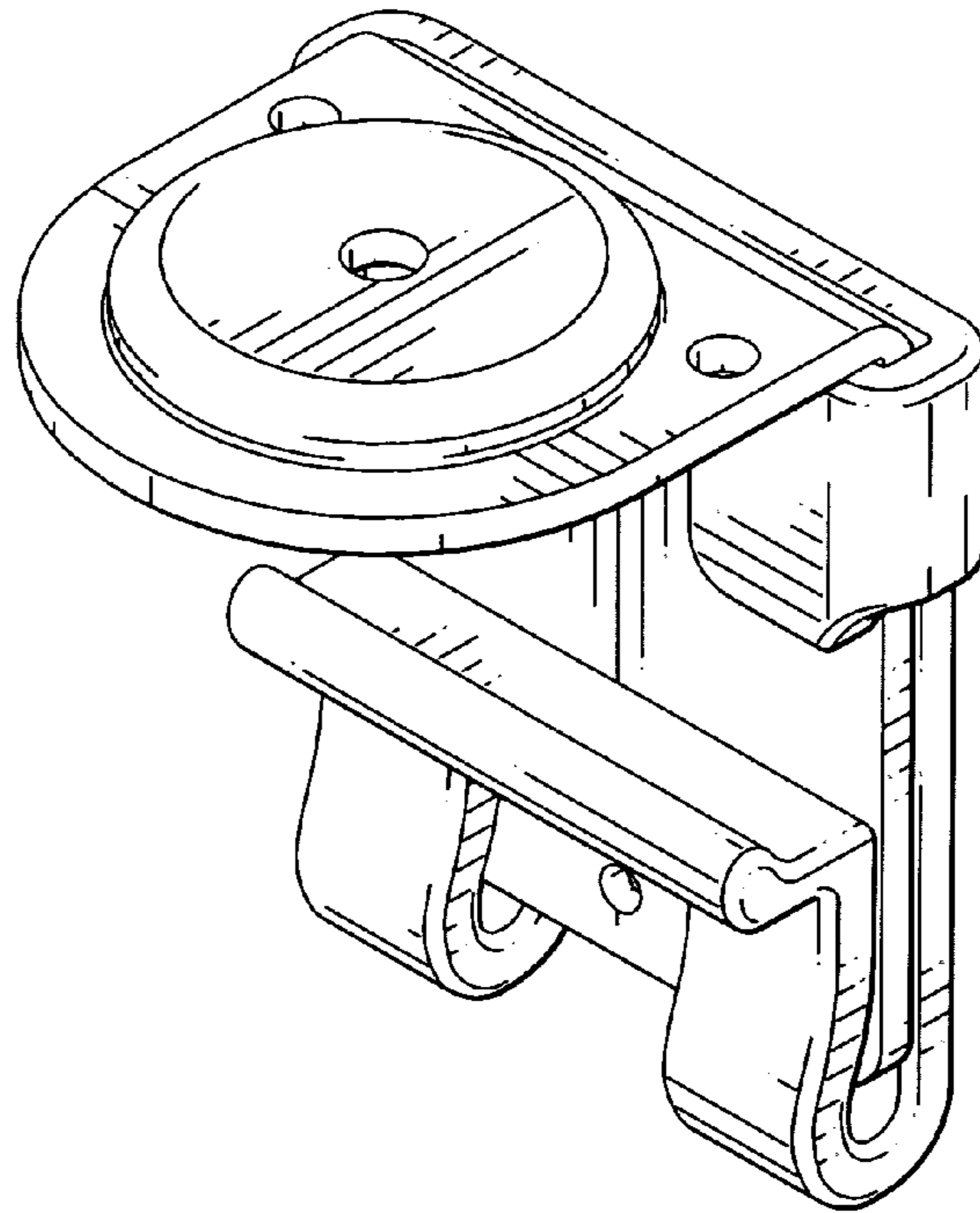

FIG. 1

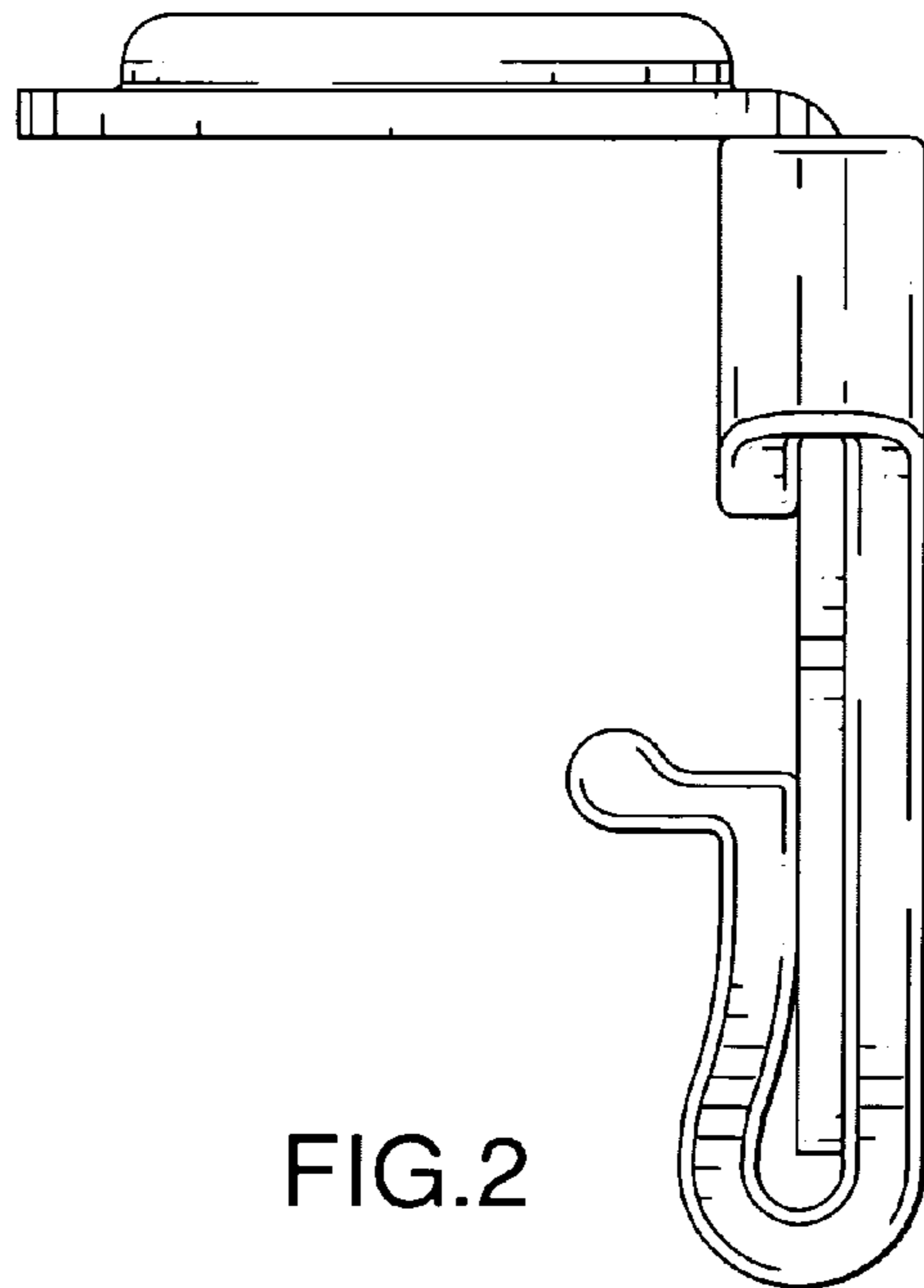

FIG. 2

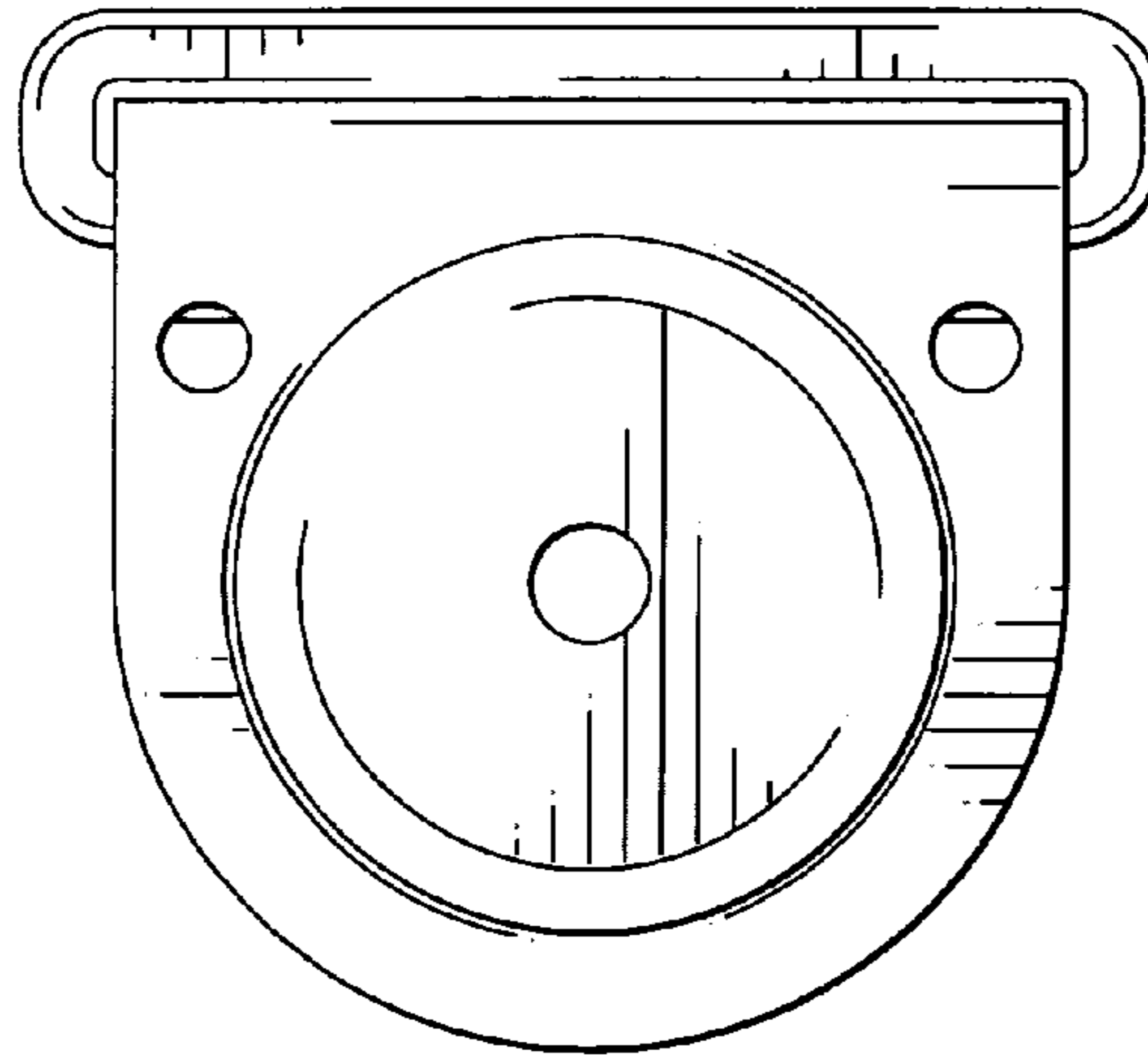

FIG. 3

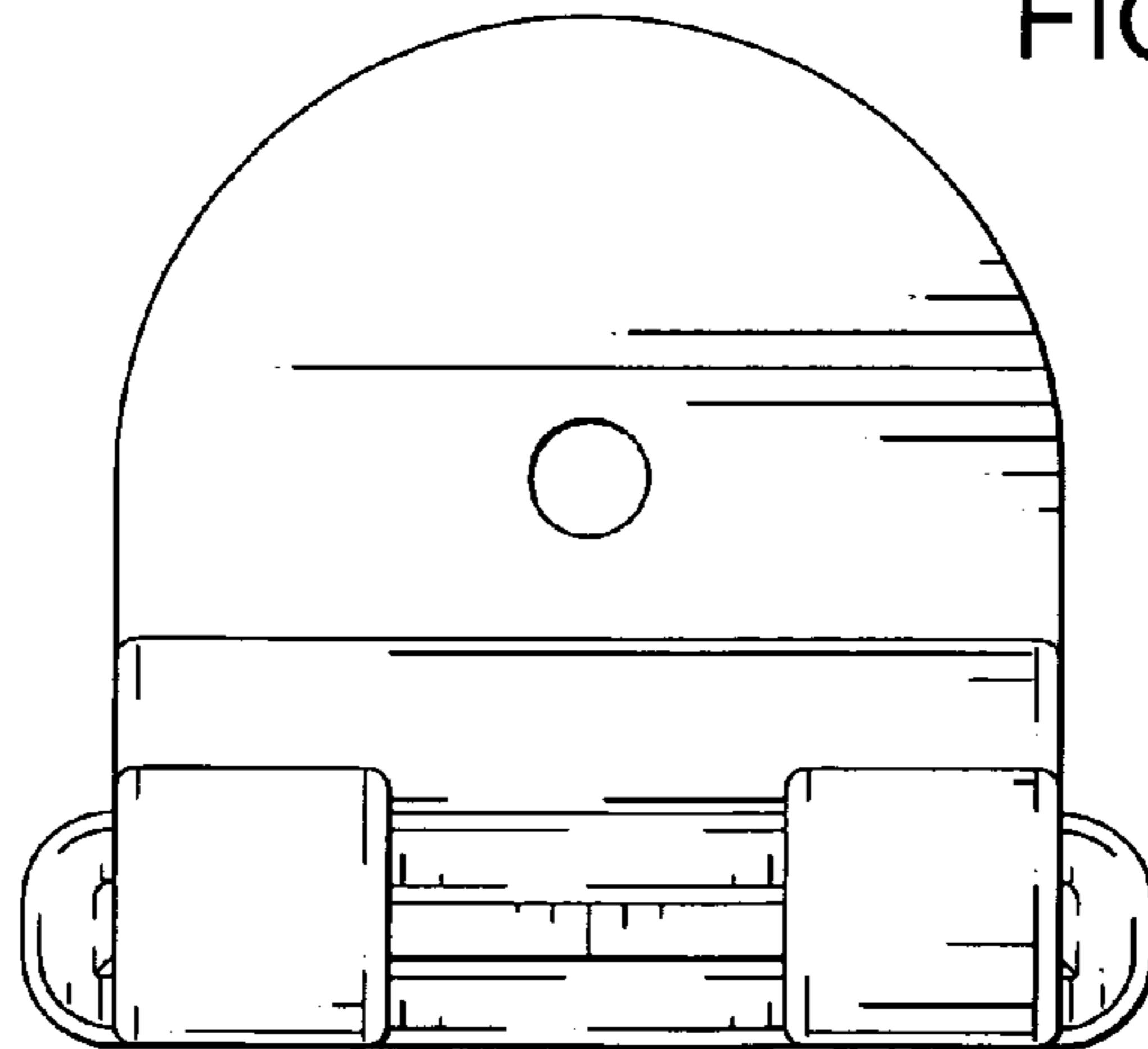

FIG. 4

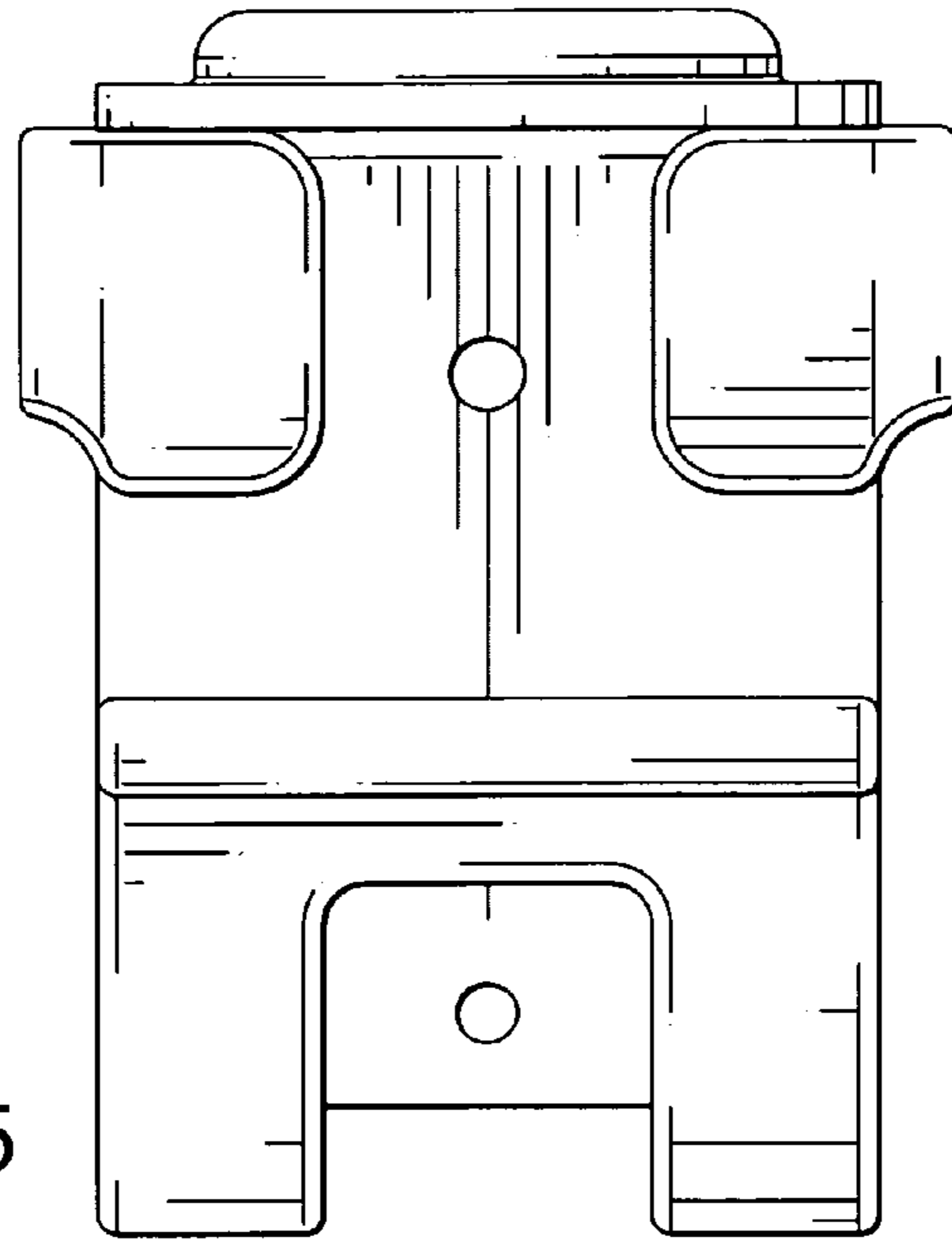

FIG. 5

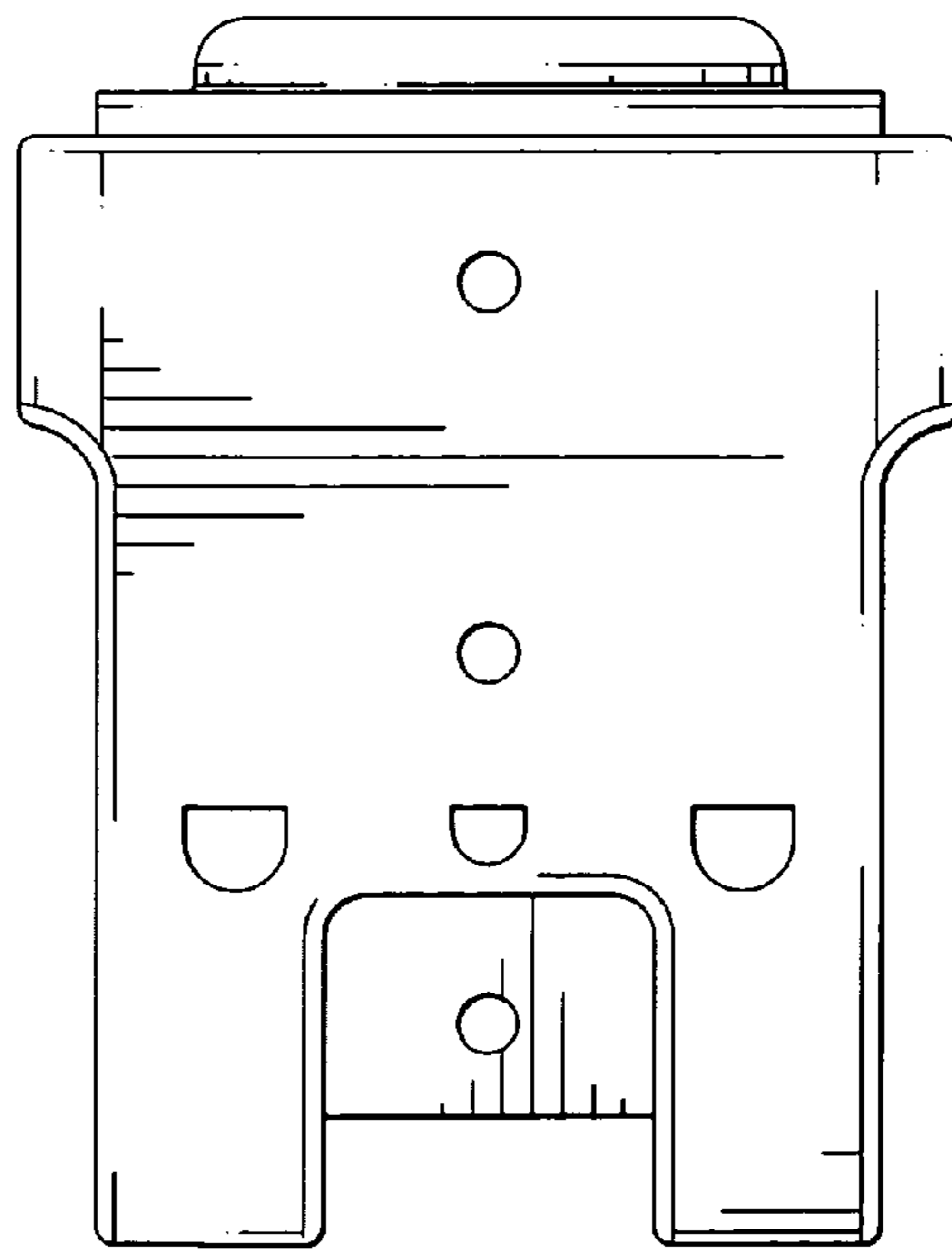
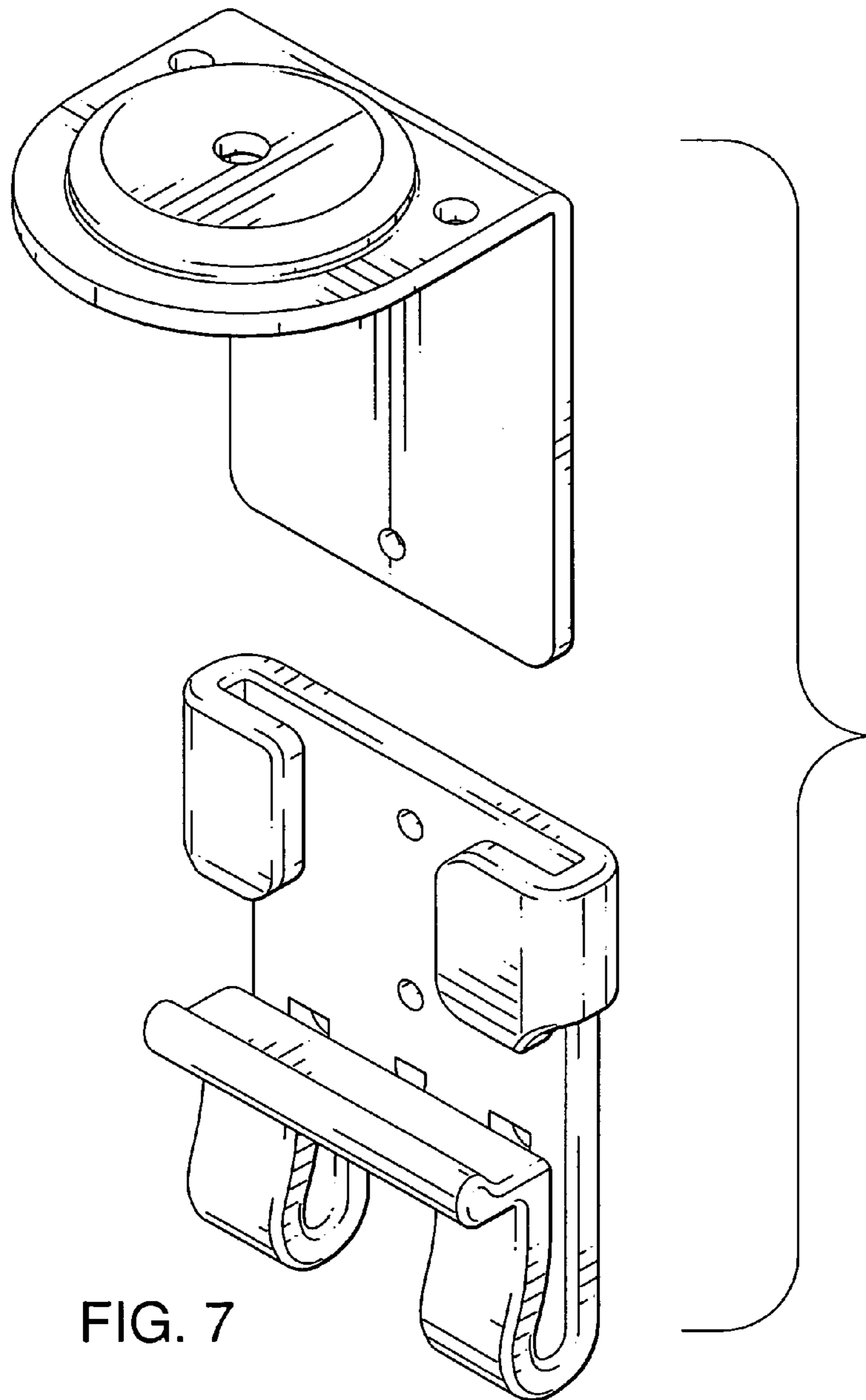

FIG. 6



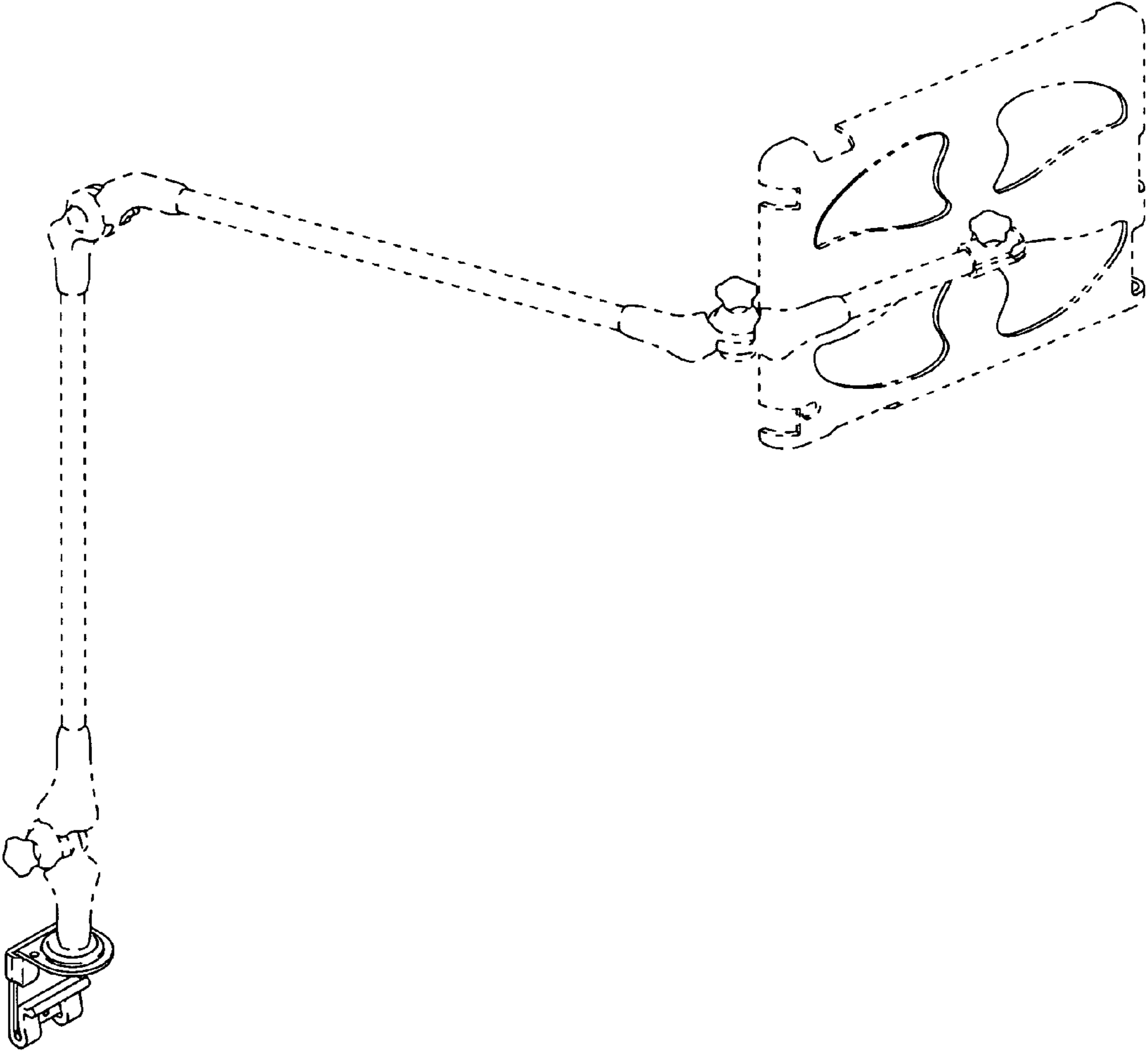

FIG. 8