



US00D671483S

(12) **United States Design Patent**
Chung

(10) **Patent No.:** **US D671,483 S**

(45) **Date of Patent:** **** Nov. 27, 2012**

- (54) **WHEEL**
- (75) Inventor: **Suny Chung**, Yorba Linda, CA (US)
- (73) Assignee: **Wheel Pros, LLC**, Lakewood, CO (US)
- (**) Term: **14 Years**
- (21) Appl. No.: **29/425,038**
- (22) Filed: **Jun. 19, 2012**

Primary Examiner — Stacia Cadmus
 (74) *Attorney, Agent, or Firm* — Garcia-Zamor IP Law; Ruy M. Garcia-Zamor

Related U.S. Application Data

- (63) Continuation of application No. 29/413,445, filed on Feb. 15, 2012.
- (51) **LOC (9) Cl.** **12-16**
- (52) **U.S. Cl.** **D12/211**
- (58) **Field of Classification Search** D12/204–213;
301/37.101, 64.101, 65, 64.201
See application file for complete search history.

(57) **CLAIM**
 The ornamental design for a wheel, as shown and described.

DESCRIPTION

FIG. 1 is a perspective view of a wheel showing my new design;
 FIG. 2 is a front elevational view of the wheel of FIG. 1;
 FIG. 3 is a left side elevational view of the wheel of FIG. 1, the right side elevational view of the wheel of FIG. 1 is a mirror image of FIG. 3;
 FIG. 4 is a top plan view of the wheel of FIG. 1;
 FIG. 5 is a bottom plan view of the wheel of FIG. 1;
 FIG. 6 is a rear elevational view of the wheel of FIG. 1;
 FIG. 7 is a perspective view of a wheel according to a second preferred embodiment of my new design;
 FIG. 8 is a front elevational view of the wheel of FIG. 7;
 FIG. 9 is a left side elevational view of the wheel of FIG. 7, the right side elevational view of the wheel of FIG. 7 is a mirror image of FIG. 9;
 FIG. 10 is a top plan view of the wheel of FIG. 7;
 FIG. 11 is a bottom plan view of the wheel of FIG. 7; and,
 FIG. 12 is a rear elevational view of the wheel of FIG. 7.
 The broken lines in FIGS. 1-12 represent environment and are for illustrative purposes only and do not constitute part of the claimed design.

(56) **References Cited**

U.S. PATENT DOCUMENTS

D408,346 S *	4/1999	Goplen	D12/211
D454,107 S *	3/2002	Chung	D12/211
D567,732 S *	4/2008	Chung	D12/209
D593,021 S *	5/2009	Chung	D12/211
D625,241 S *	10/2010	Zhao	D12/211
D629,347 S *	12/2010	Kim	D12/211
D638,763 S *	5/2011	Chung	D12/209
D644,156 S *	8/2011	Johnson	D12/209
D655,233 S *	3/2012	Alfonso	D12/211
D656,445 S *	3/2012	Lee	D12/209
D659,063 S *	5/2012	Johnson	D12/209
D659,067 S *	5/2012	Lee	D12/209
D659,069 S *	5/2012	Johnson	D12/211

* cited by examiner

1 Claim, 10 Drawing Sheets

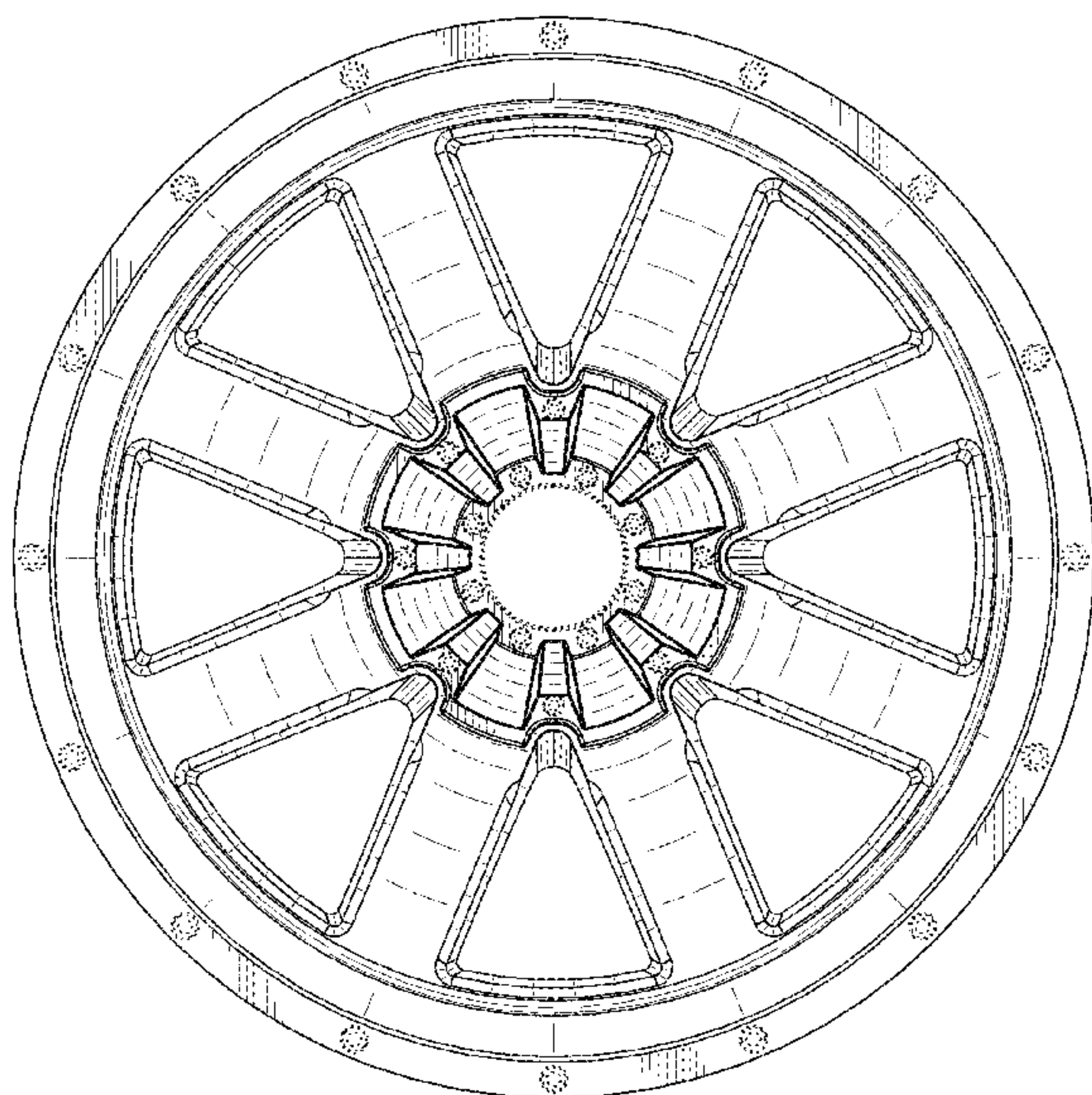
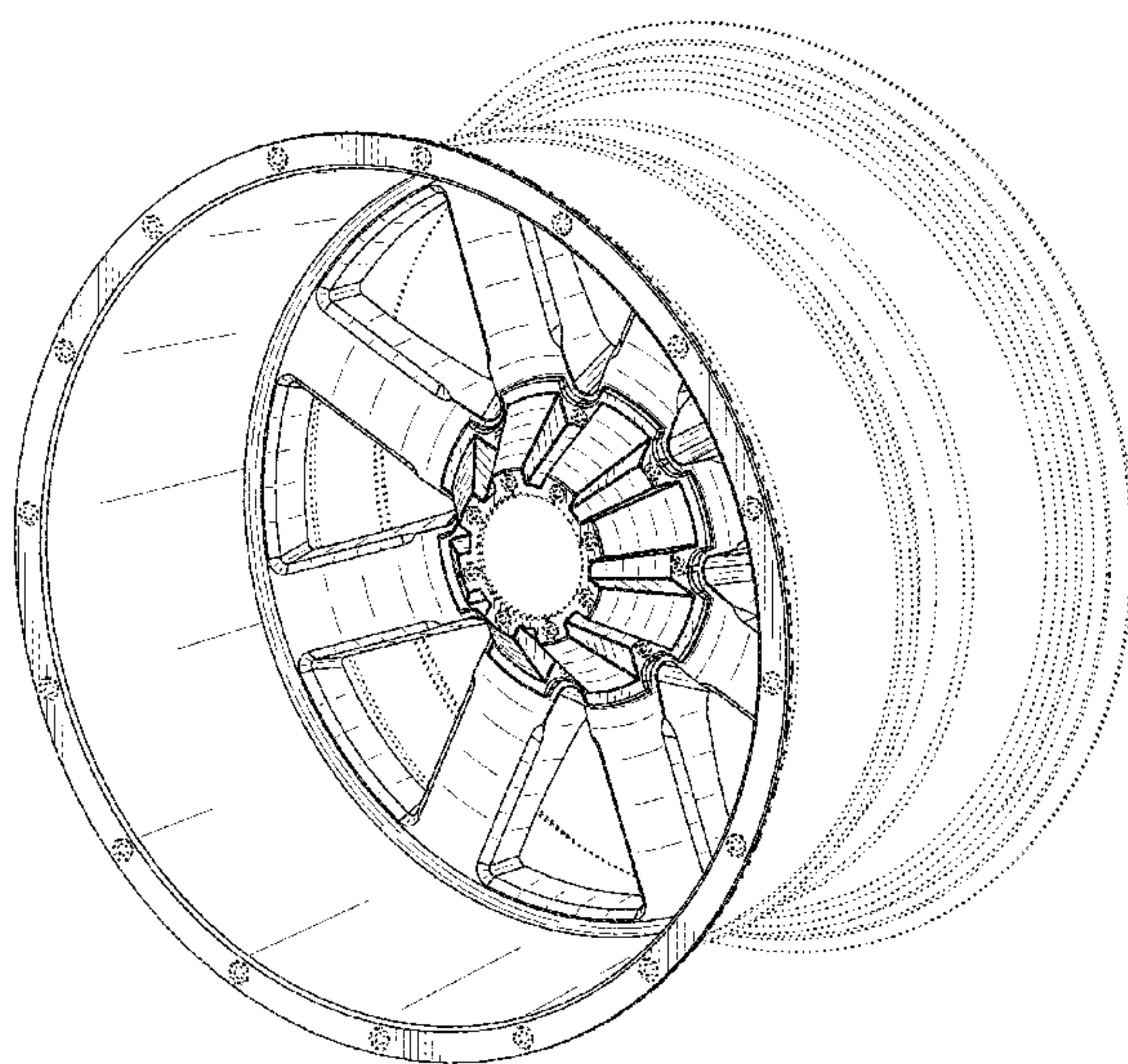

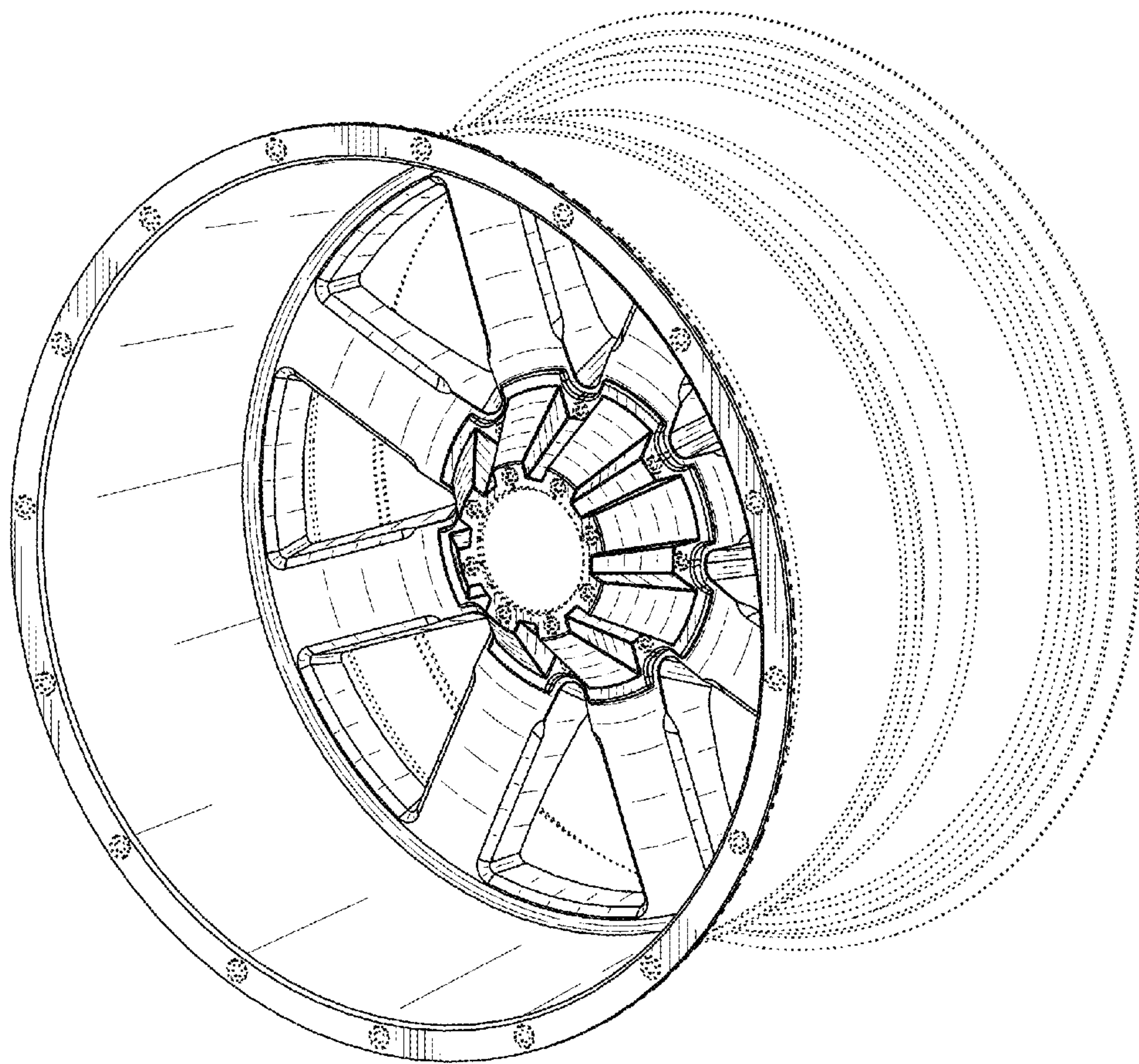

FIG. 1

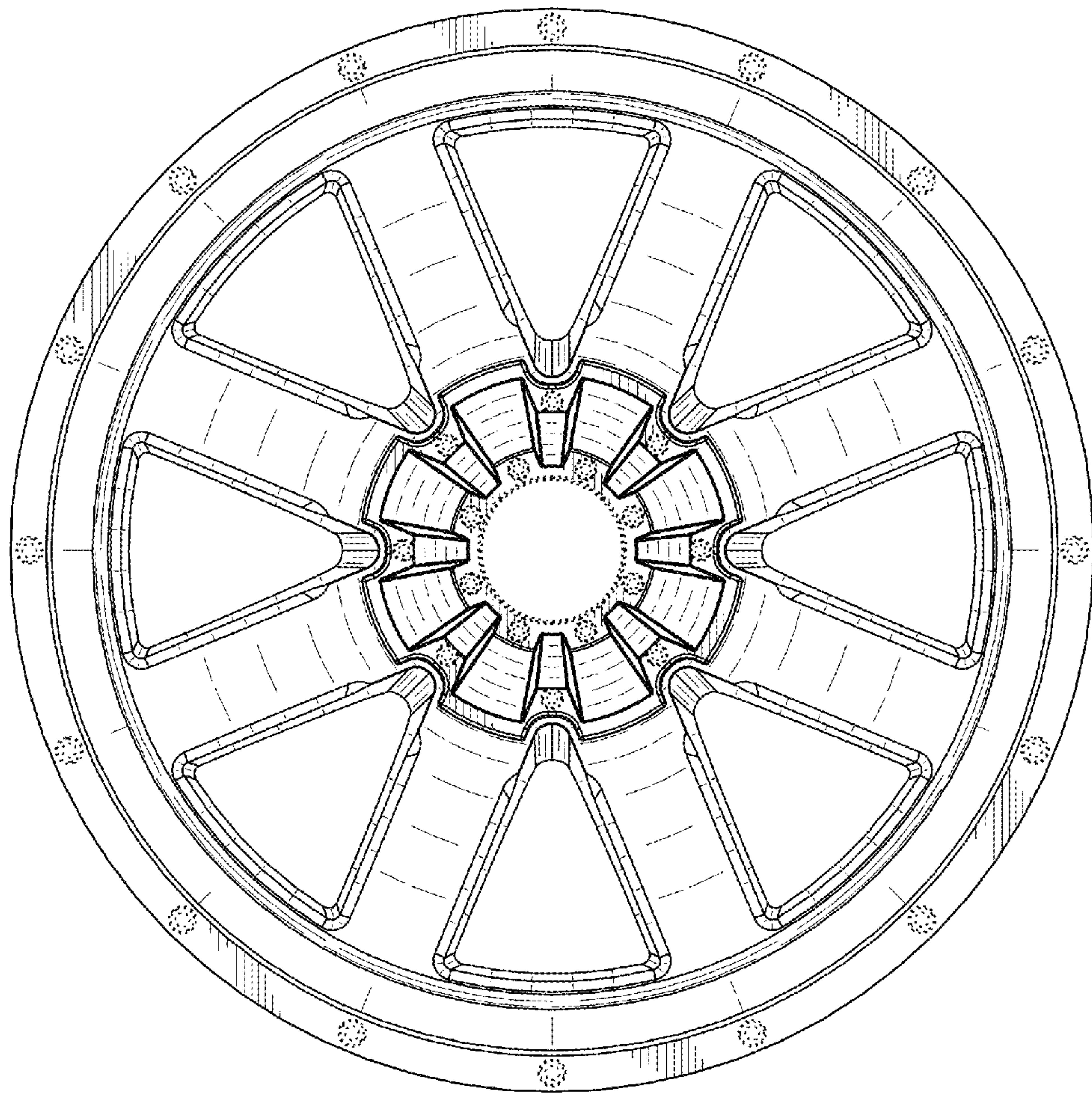

FIG. 2

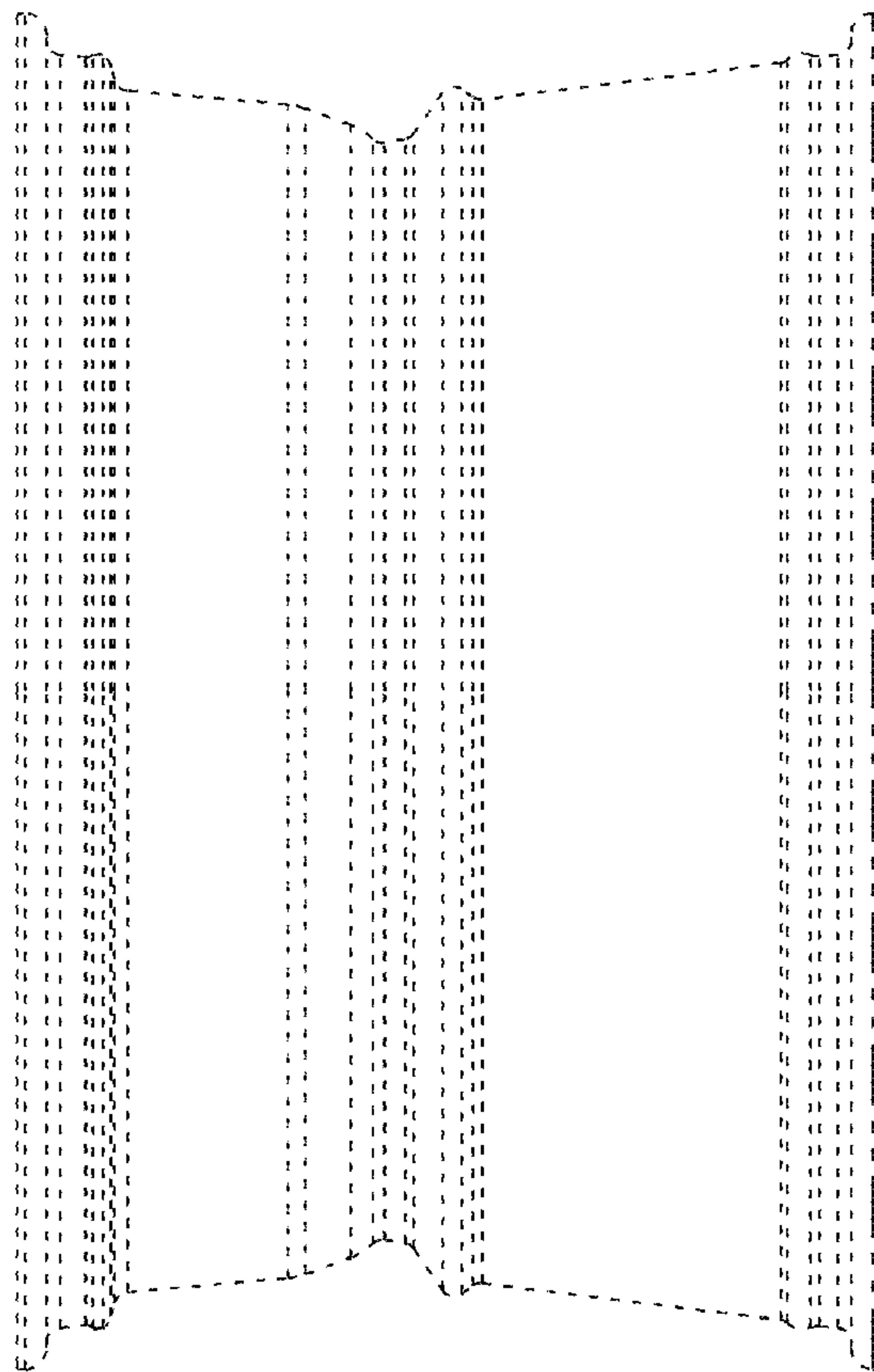

FIG. 3



FIG. 4



FIG. 5

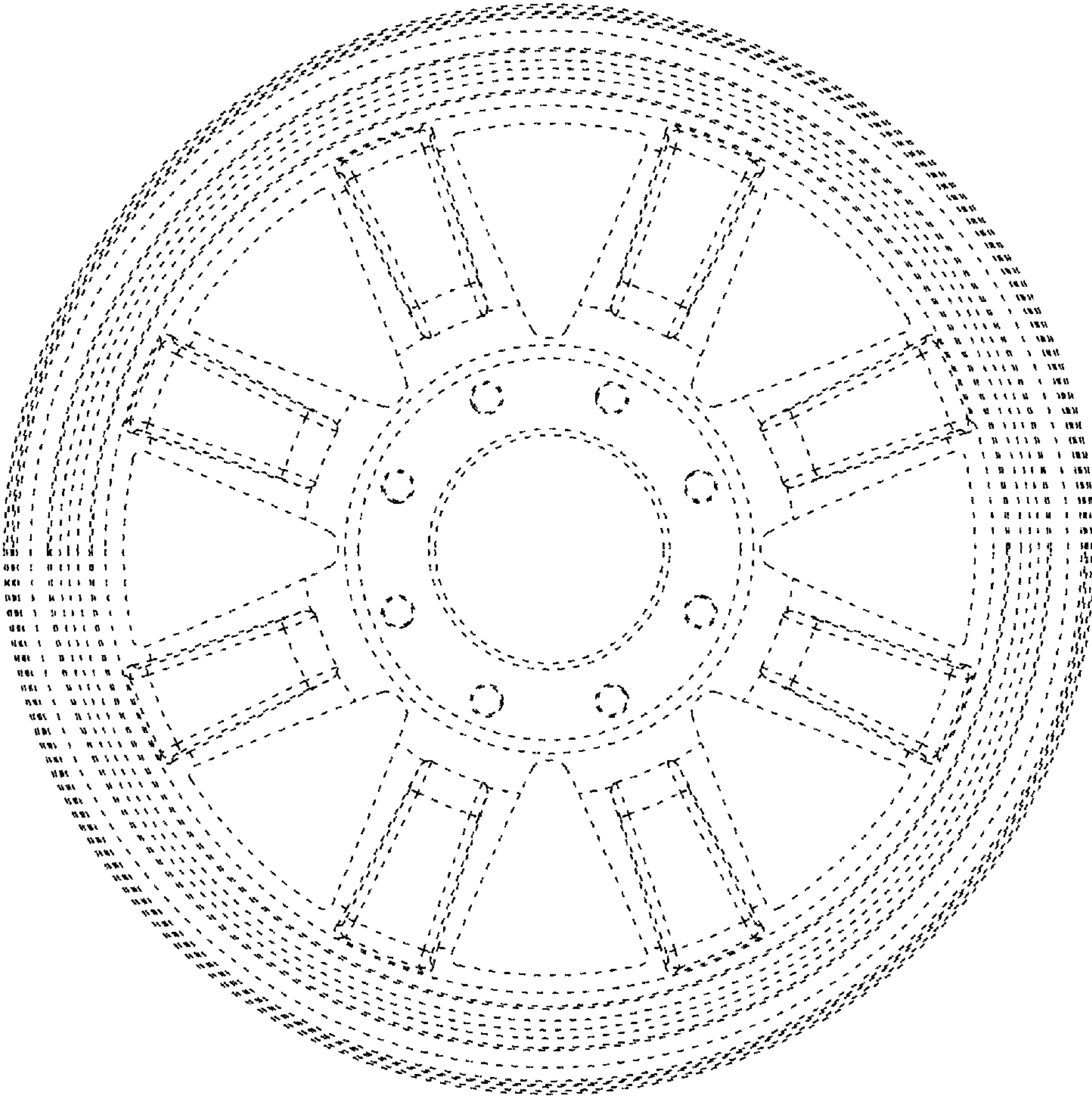

FIG. 6

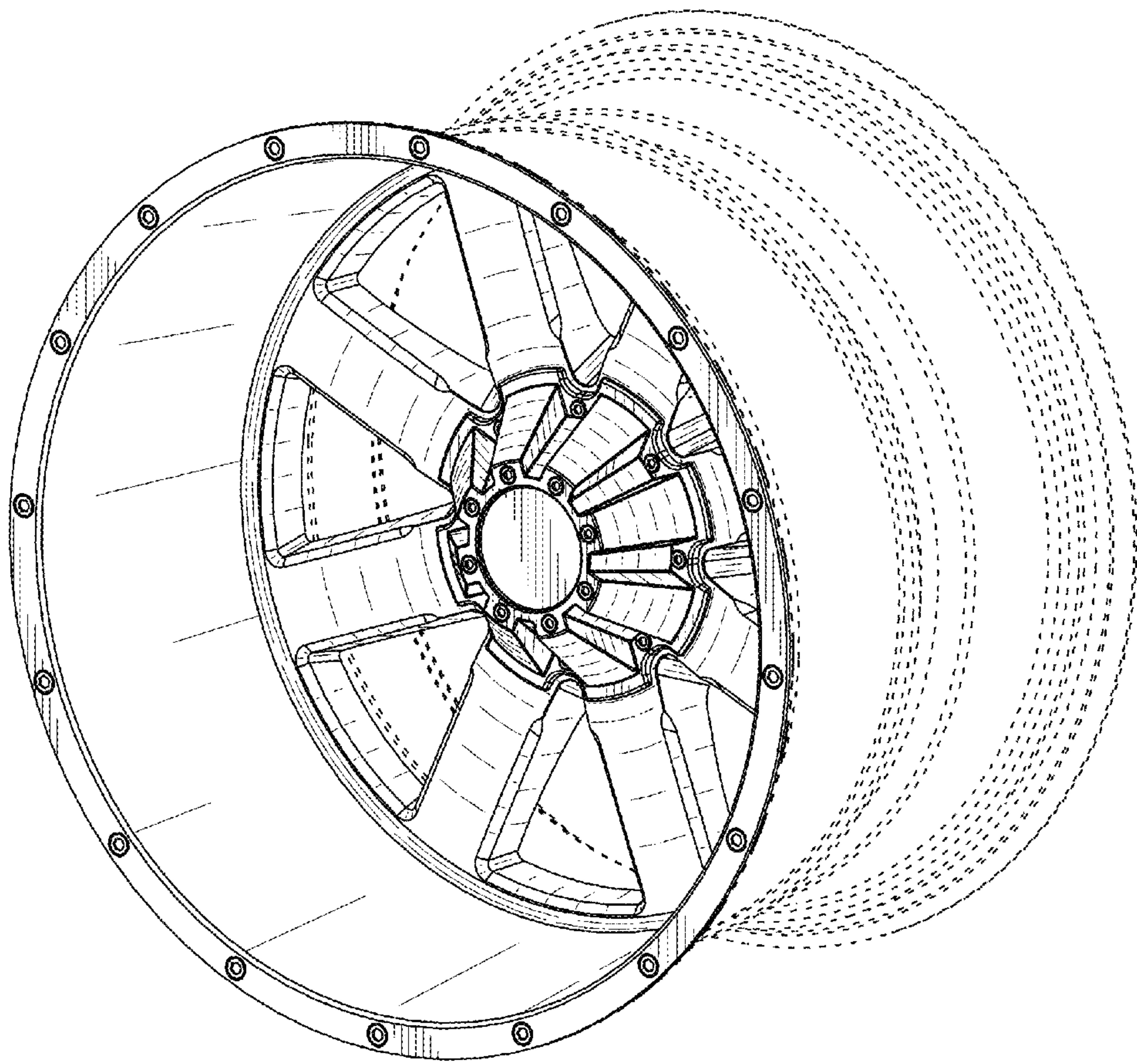

FIG. 7

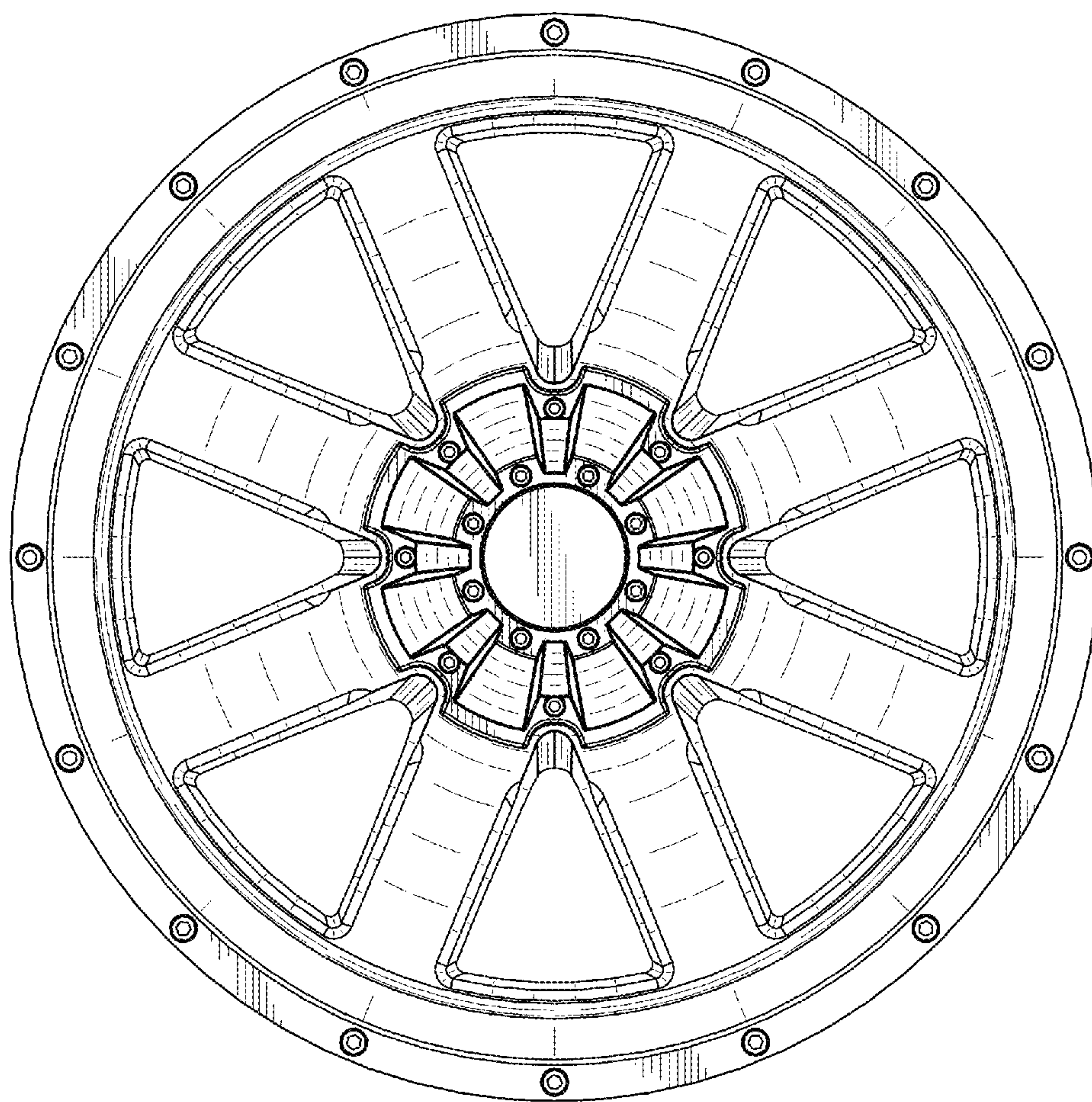

FIG. 8



FIG. 10



FIG. 11

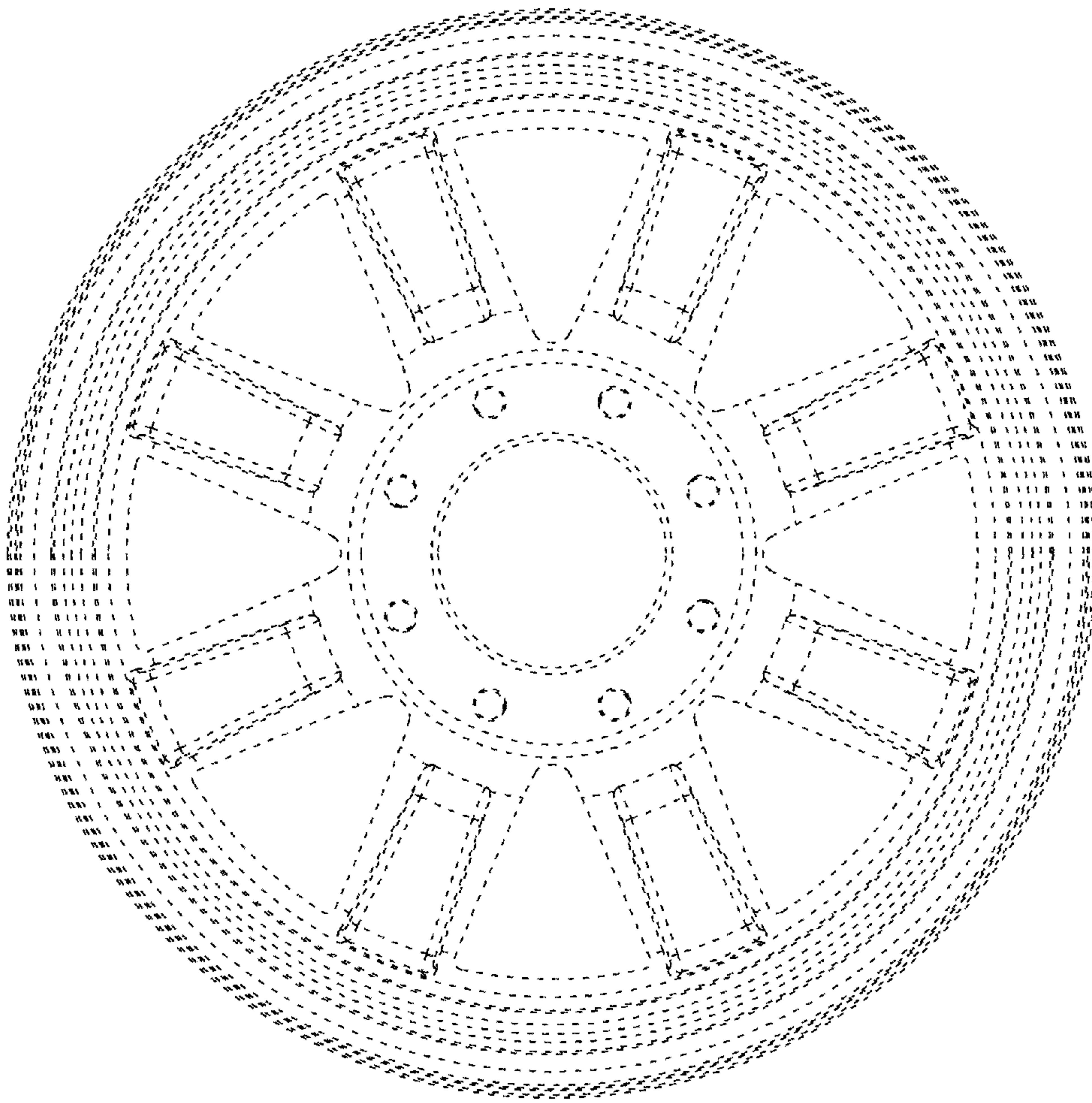

FIG. 12