



US00D671398S

(12) **United States Design Patent**
Armstrong et al.

(10) **Patent No.:** **US D671,398 S**
(45) **Date of Patent:** **** Nov. 27, 2012**

(54) **PACKAGING**

(75) Inventors: **Mark Armstrong**, Gwynedd (GB); **Dale Mark Nicholls**, Mitchum (GB); **Terry Xu**, Shanghai (CN); **Johnny Xu**, Shanghai (CN); **Ronald Menno Victor Wienia**, Shanghai (CN)

(73) Assignee: **Koninklijke Philips Electronics N.V.**, Eindhoven (NL)

(**) Term: **14 Years**

(21) Appl. No.: **29/396,575**

(22) Filed: **Jul. 1, 2011**

(30) **Foreign Application Priority Data**

Jan. 4, 2011 (EM) 001801176-0001

(51) **LOC (9) Cl.** **09-03**

(52) **U.S. Cl.** **D9/415**

(58) **Field of Classification Search** D9/715,
D9/718, 721, 722, 737, 414-436; 206/461-471,
206/278, 292, 722-728, 349-383, 457, 459.5,
206/775-783, 806, 822
See application file for complete search history.

(56) **References Cited**

U.S. PATENT DOCUMENTS

| | | | | | | |
|-----------|---|---|---------|-------------|-------|---------|
| D180,763 | S | * | 8/1957 | Bond et al. | | D9/415 |
| 3,066,790 | A | * | 12/1962 | Armbruster | | 206/305 |
| D207,805 | S | * | 5/1967 | Nowak | | D9/418 |
| D212,076 | S | * | 8/1968 | Katz | | D9/457 |
| D231,201 | S | * | 4/1974 | Bonfitto | | D9/418 |
| 4,191,289 | A | * | 3/1980 | Austin | | 206/780 |
| D278,596 | S | * | 4/1985 | Ceraulo | | D9/759 |

| | | | | | | |
|----------|---|---|---------|--------------|-------|--------|
| D298,607 | S | * | 11/1988 | Didia | | D9/415 |
| D313,753 | S | * | 1/1991 | Nagasaka | | D9/415 |
| D413,512 | S | * | 9/1999 | Pryde et al. | | D9/415 |
| D466,405 | S | * | 12/2002 | Lee | | D9/415 |
| D541,145 | S | * | 4/2007 | Copp | | D9/415 |
| D618,539 | S | * | 6/2010 | Ruth | | D9/415 |

FOREIGN PATENT DOCUMENTS

| | | | |
|----|----------------|---|---------|
| EM | 000188248-0002 | * | 9/2004 |
| EM | 000764642-0008 | * | 8/2007 |
| EM | 001204036-0001 | * | 4/2010 |
| EM | 001732041-0006 | * | 7/2010 |
| WO | D063149-005 | * | 3/2003 |
| WO | D066517-001 | * | 7/2005 |
| WO | D068364-001 | * | 12/2006 |

* cited by examiner

Primary Examiner — Catherine Tuttle

(57) **CLAIM**

The ornamental design for a packaging, as shown and described.

DESCRIPTION

FIG. 1 is a perspective view of the packaging showing our new design.

FIG. 2 is a front elevational view thereof;

FIG. 3 is a rear elevational view thereof;

FIG. 4 is a right side elevational view thereof;

FIG. 5 is a left side elevational view thereof;

FIG. 6 is a top plan view thereof; and,

FIG. 7 is a bottom plan view thereof.

The broken lines shown in FIG. 7 are included for the purpose of illustrating a portion of the packaging that forms no part of the claimed design.

1 Claim, 5 Drawing Sheets

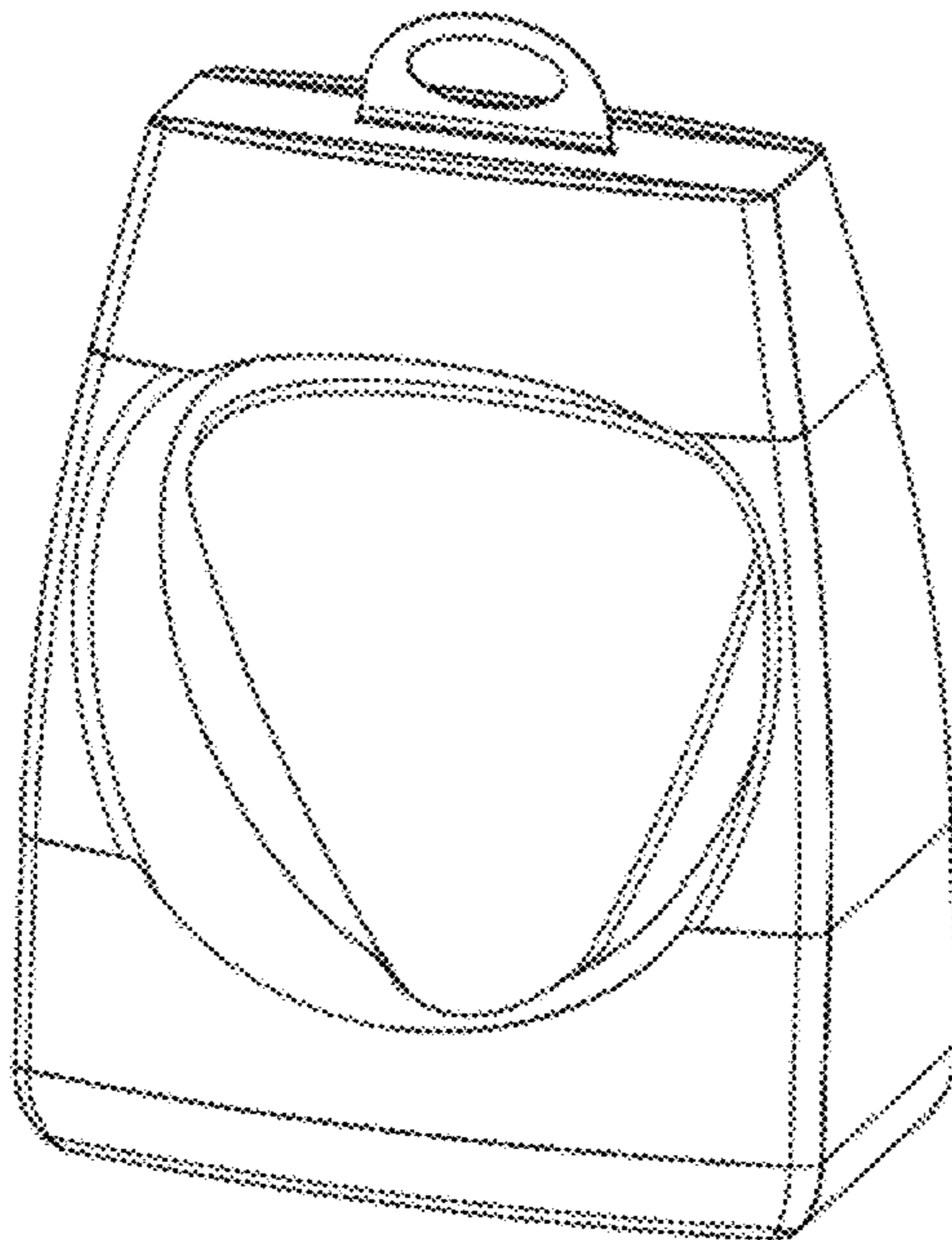

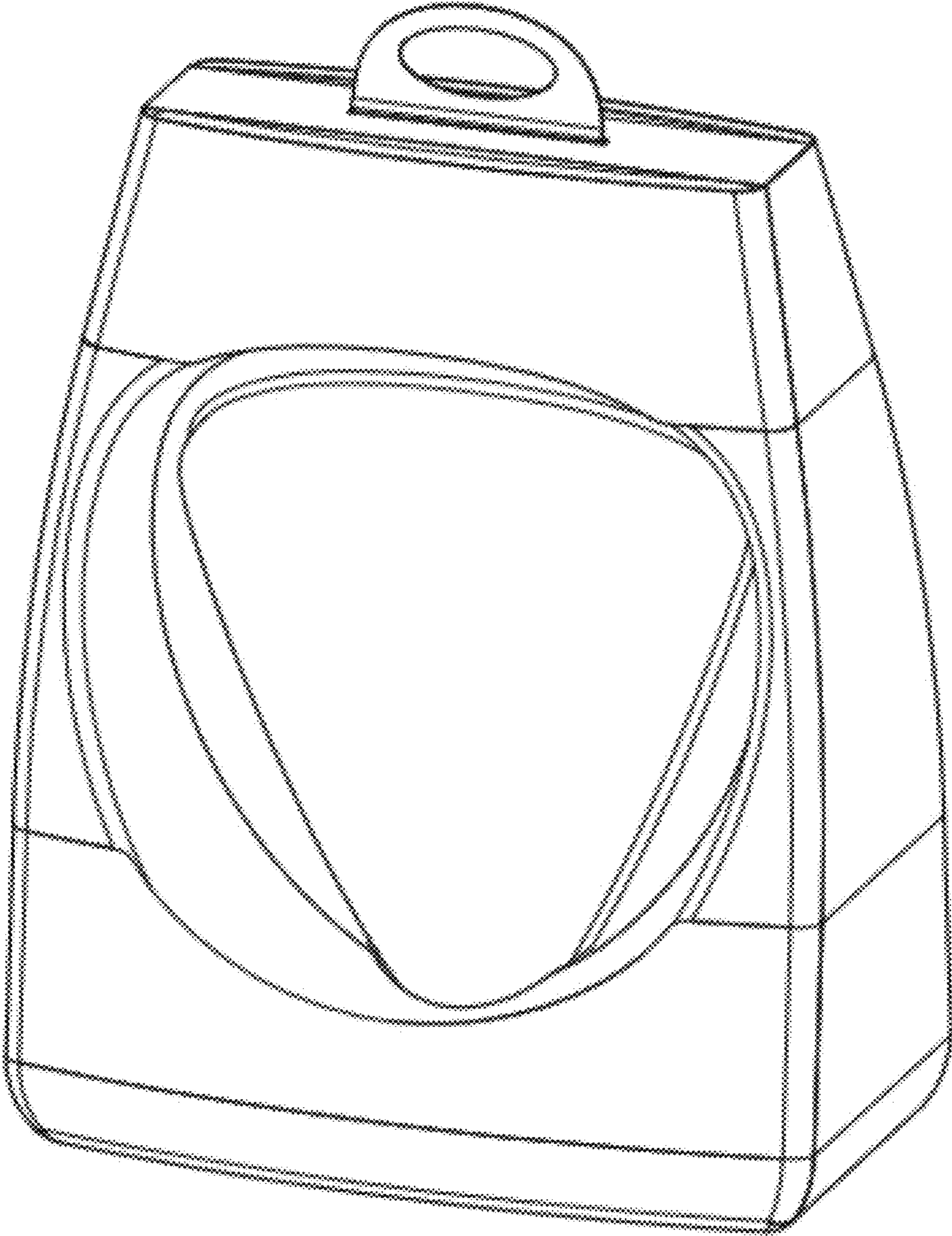

FIG. 1

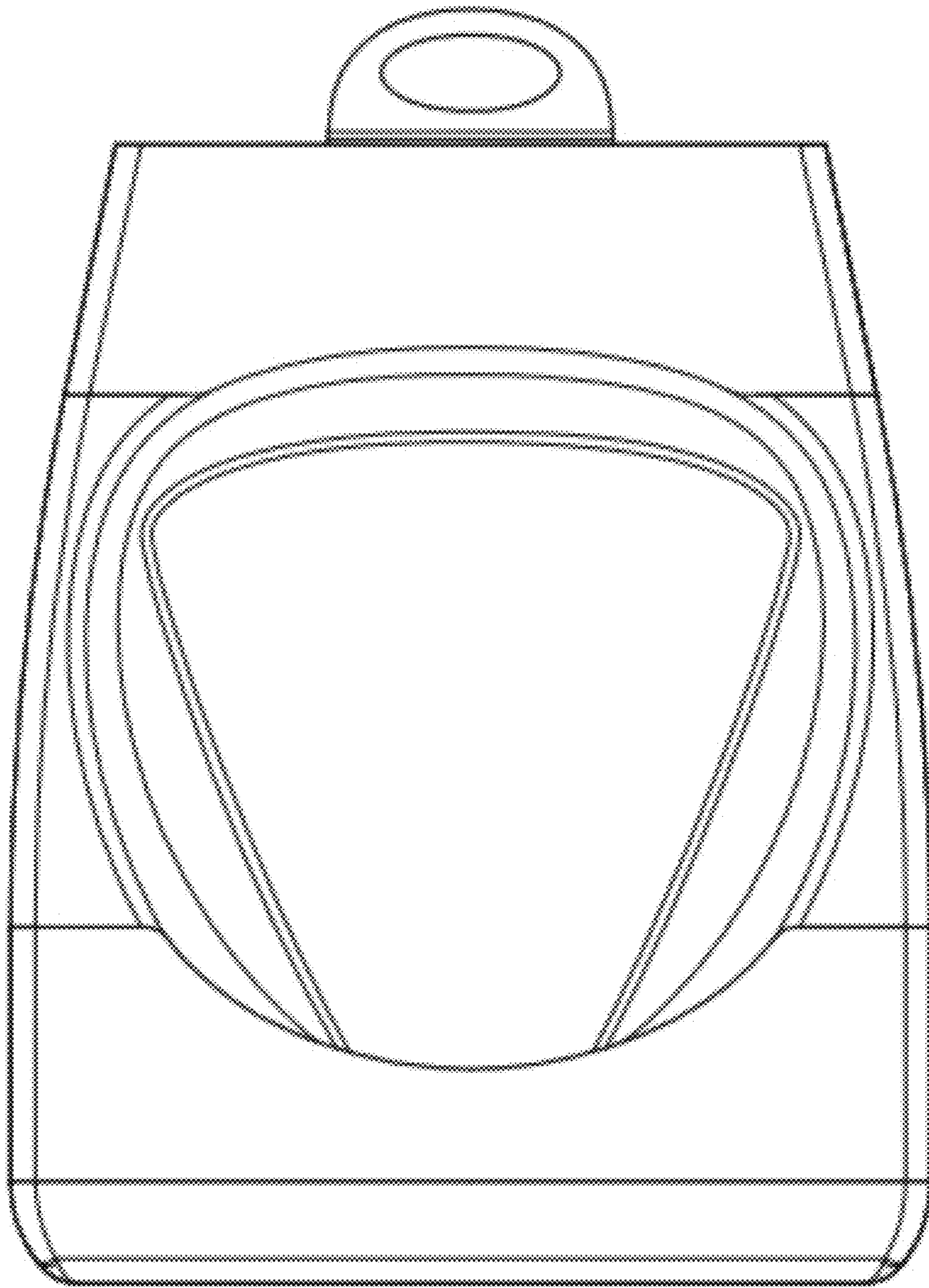

FIG. 2

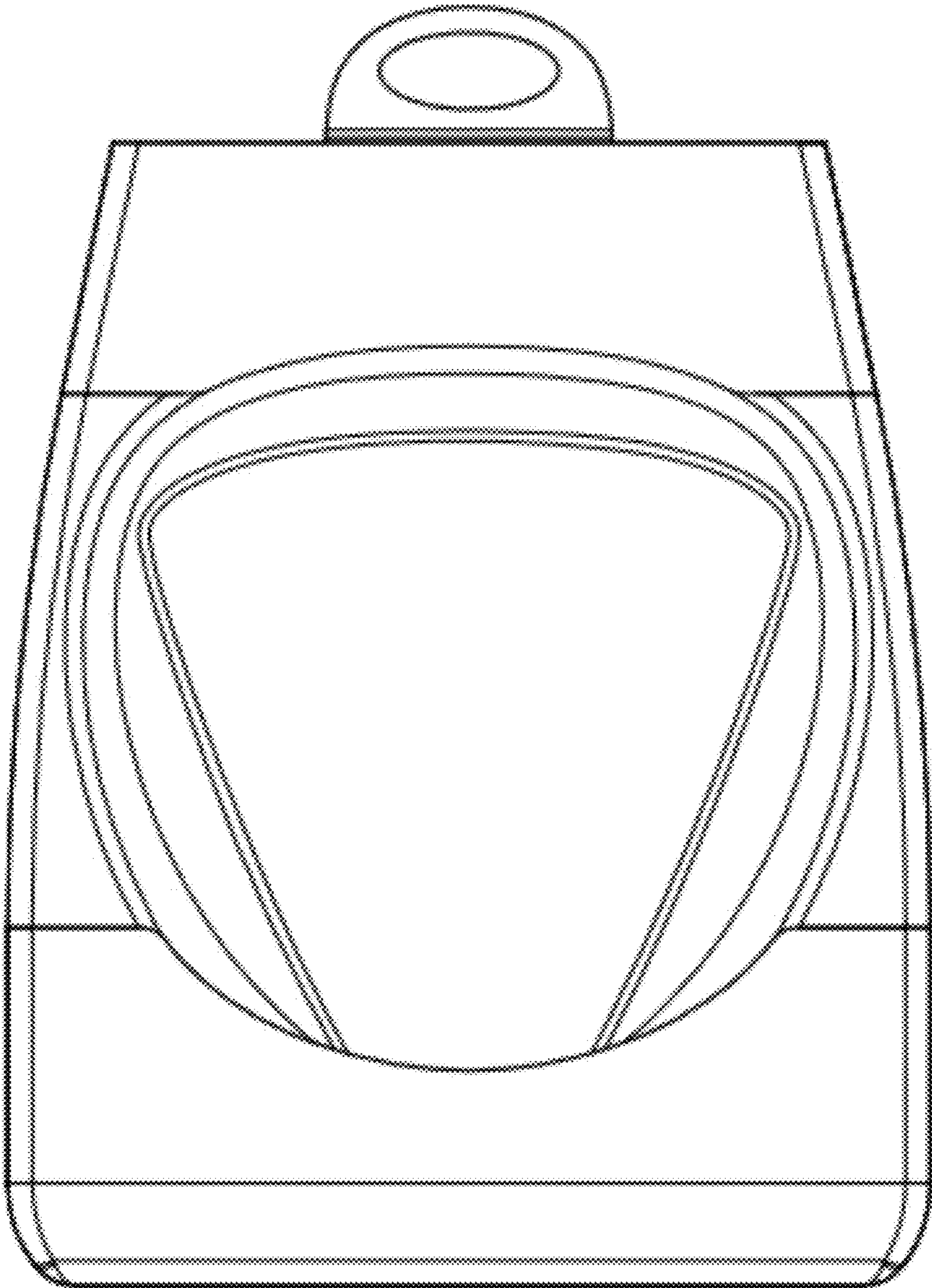

FIG. 3

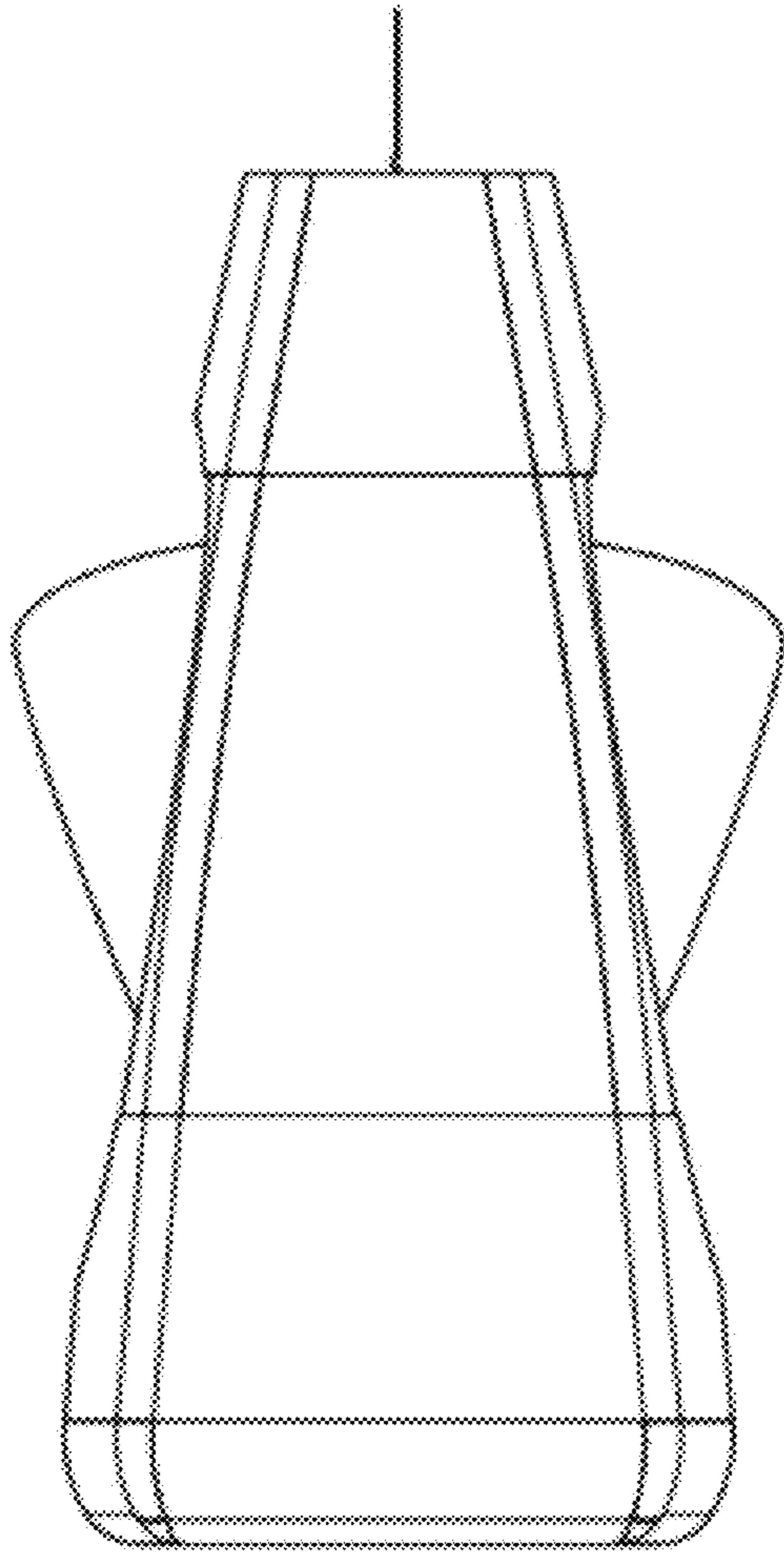

FIG. 4

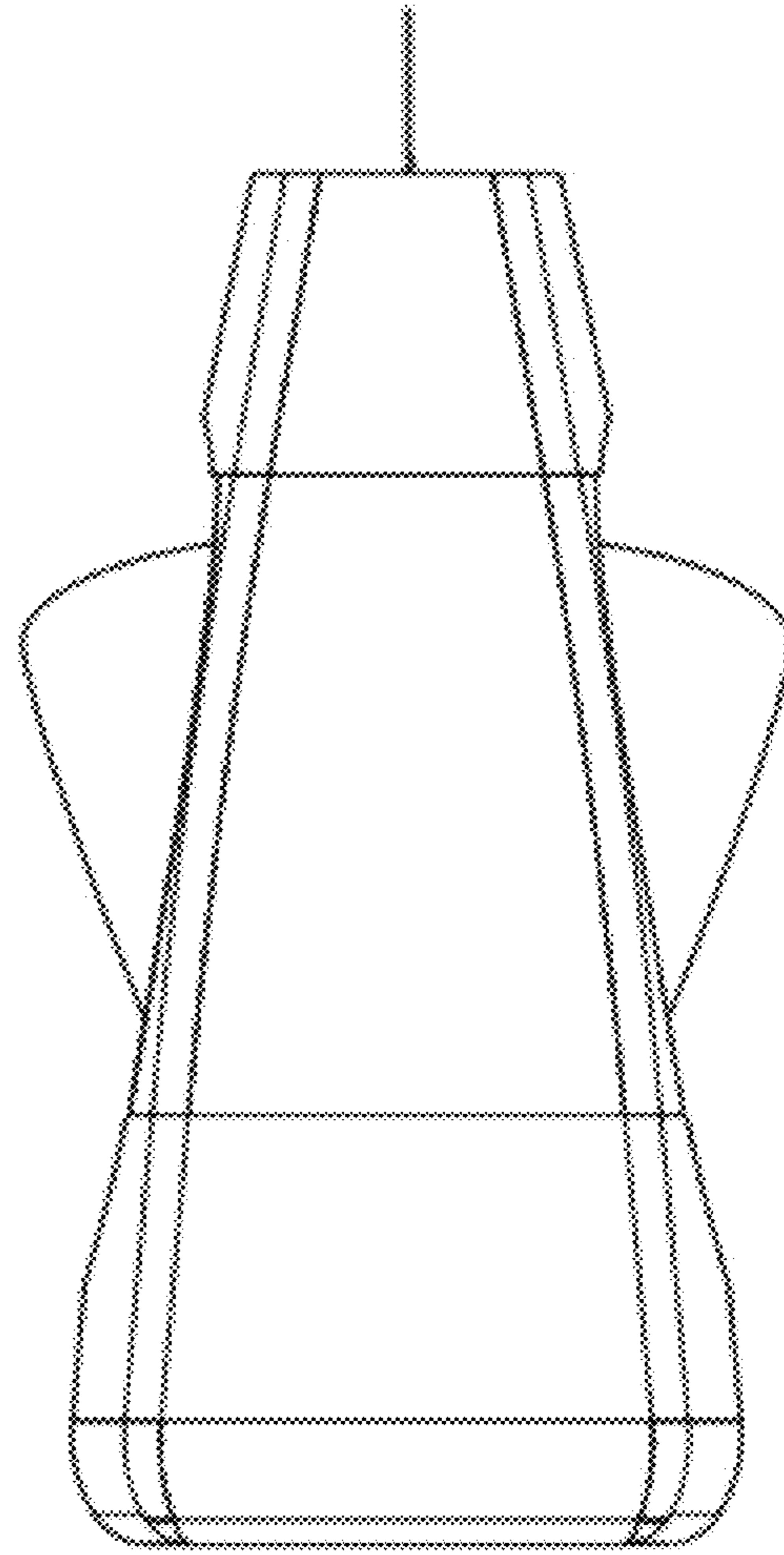

FIG. 5

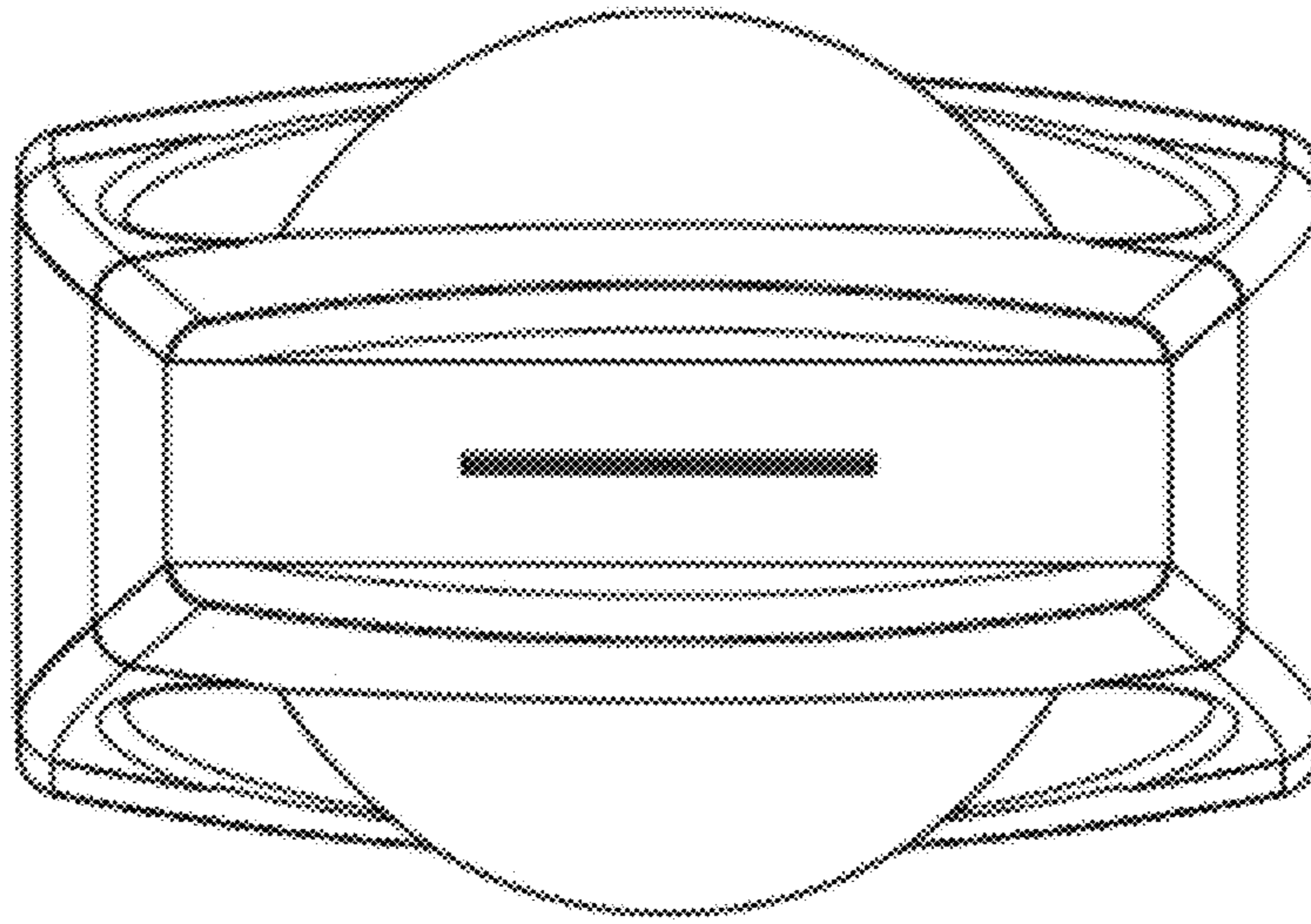

FIG. 6

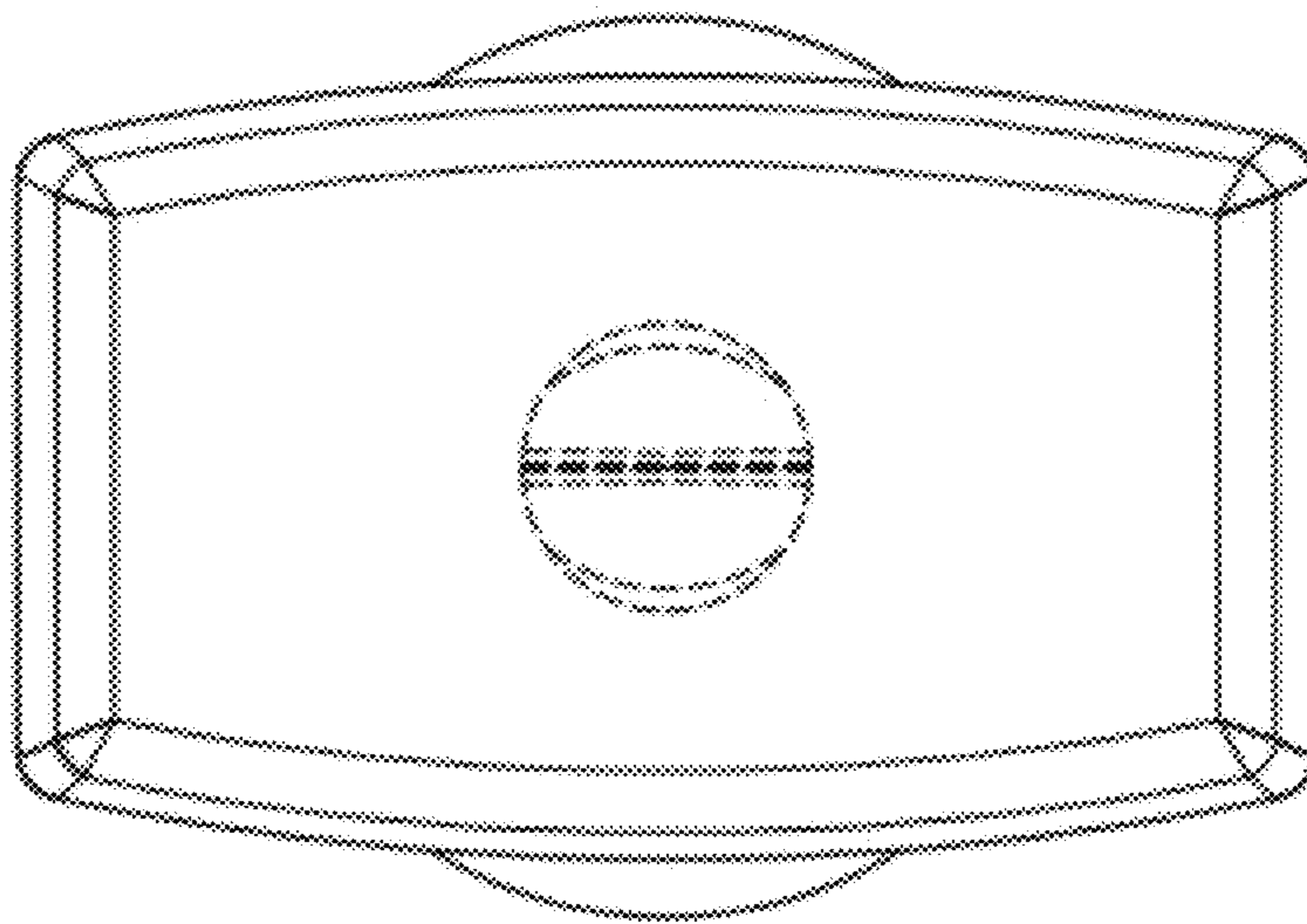

FIG. 7