



US00D671005S

(12) **United States Design Patent**
Prathummek

(10) **Patent No.:** **US D671,005 S**

(45) **Date of Patent:** **** Nov. 20, 2012**

(54) **CONTAINER**

(75) Inventor: **Supattra Prathummek**, Bangkok (TH)

(73) Assignee: **The Quaker Oats Company**, Chicago, IL (US)

(**) Term: **14 Years**

(21) Appl. No.: **29/404,193**

(22) Filed: **Oct. 17, 2011**

(51) **LOC (9) Cl.** **09-01**

(52) **U.S. Cl.** **D9/502; D9/539**

(58) **Field of Classification Search** D9/500,
D9/502-505, 516, 529-530, 537-540, 549,
D9/558, 575, 682, 686, 688-691, 435, 444-445,
D9/454, 557; D7/509-511, 523; 215/379,
215/381-382; 220/660, 669-673, 675
See application file for complete search history.

(56) **References Cited**

U.S. PATENT DOCUMENTS

D580,764 S	*	11/2008	Shale	D9/500
D581,272 S	*	11/2008	Yourist et al.	D9/502
D583,240 S	*	12/2008	Bourne	D9/500
D584,153 S	*	1/2009	Bourne	D9/502
D584,947 S	*	1/2009	Bourne	D9/502
D592,518 S	*	5/2009	Faulon	D9/539

OTHER PUBLICATIONS

Raj Ganpath, "Real food, non-food and make believe real food", <http://rajganpath.com/>, Oct. 17, 2011, p. 8, published Oct. 3, 2011.

* cited by examiner

Primary Examiner — Dana L Meyrow

(74) *Attorney, Agent, or Firm* — Banner & Witcoff, Ltd.

(57) **CLAIM**

The ornamental design for a container, as shown and described.

DESCRIPTION

FIG. 1 is a top, front perspective view of a container showing my new design;
FIG. 2 is a front view thereof;
FIG. 3 is a right side view thereof;
FIG. 4 is a rear view thereof;
FIG. 5 is a left side view thereof; and,
FIG. 6 is a top view thereof.

The uneven-length broken lines represent unclaimed boundaries of the claimed design. The even-length broken lines showing the remainder of the container are for environmental purposes only and form no part of the claimed design.

1 Claim, 6 Drawing Sheets

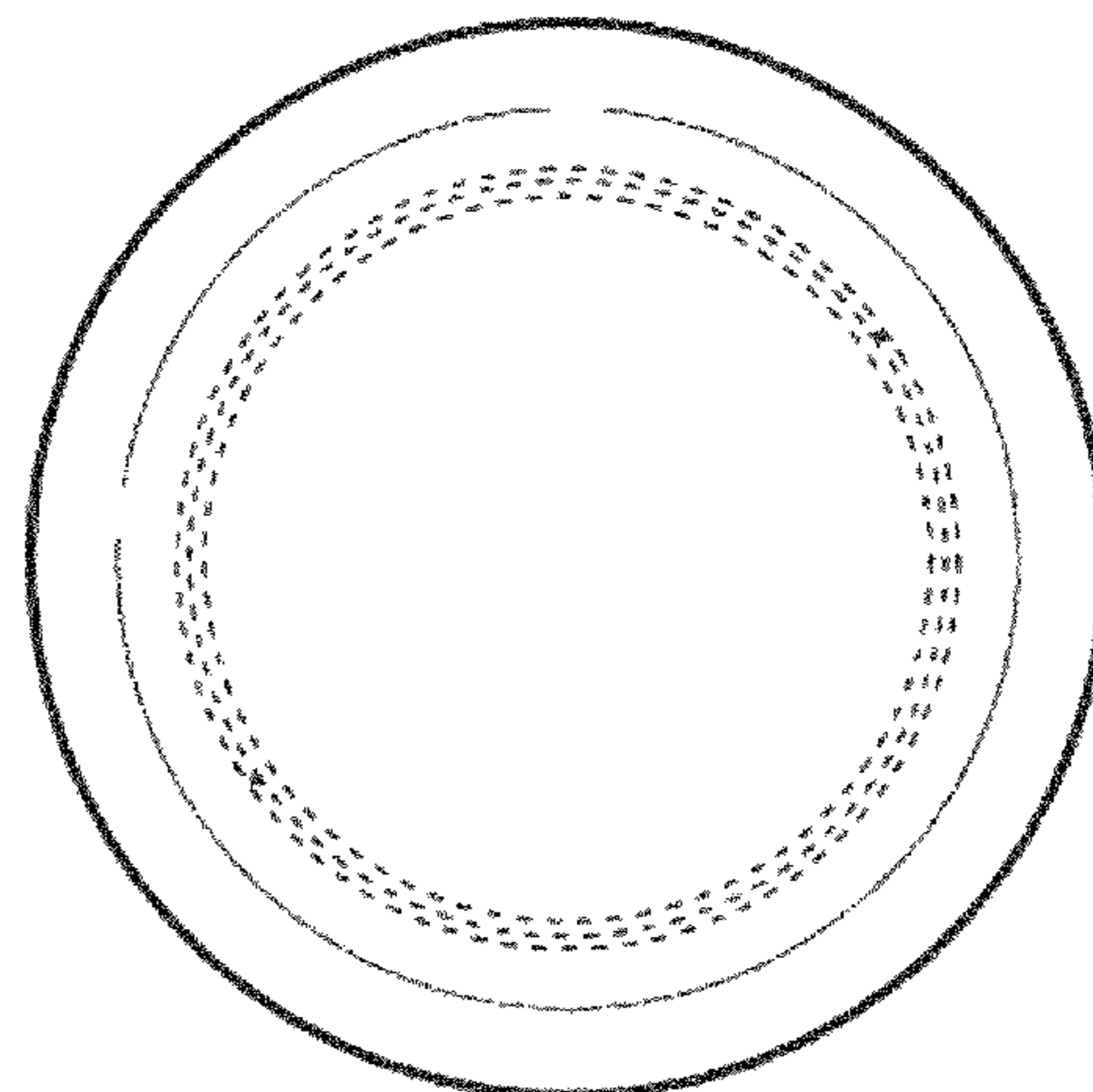
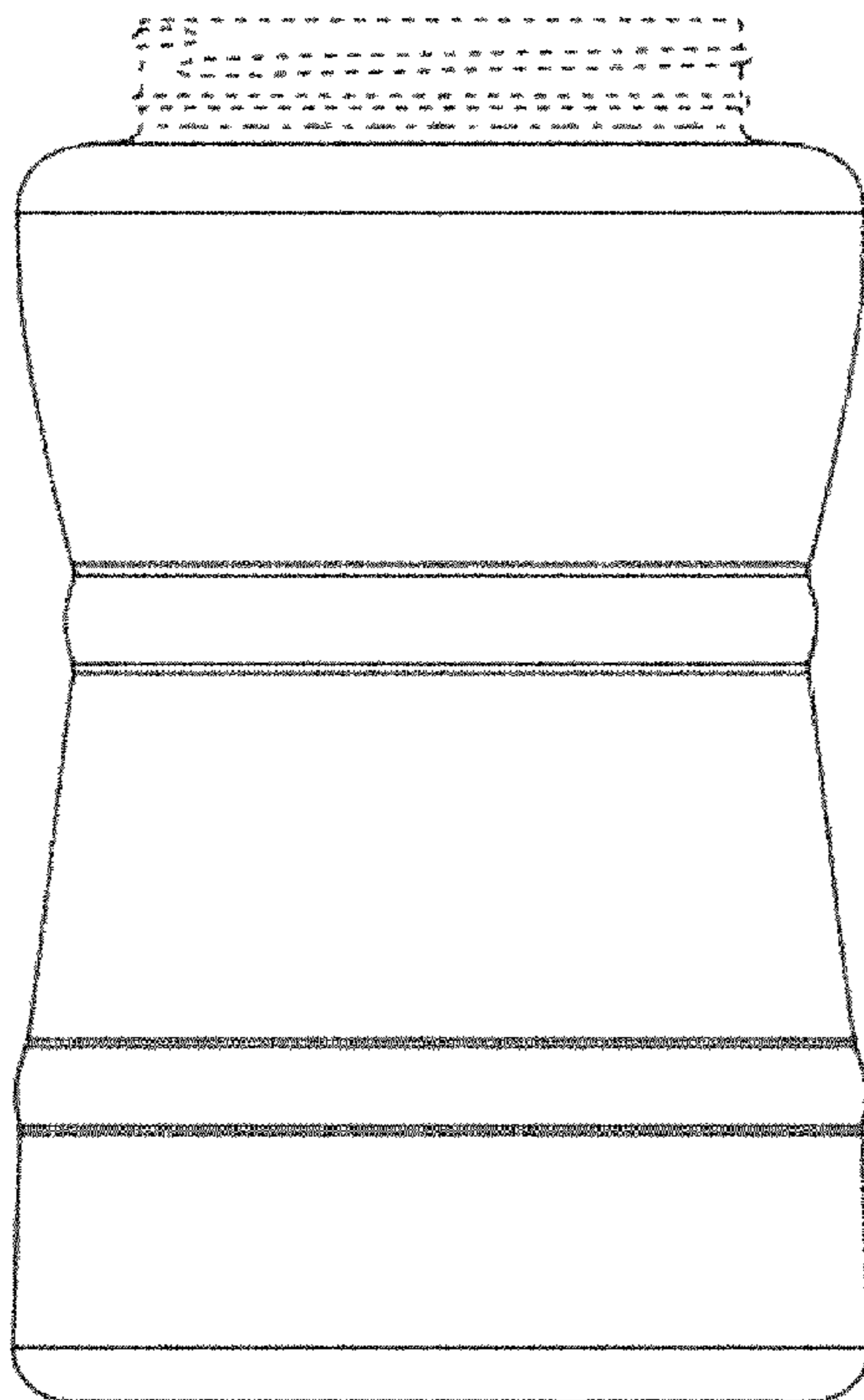

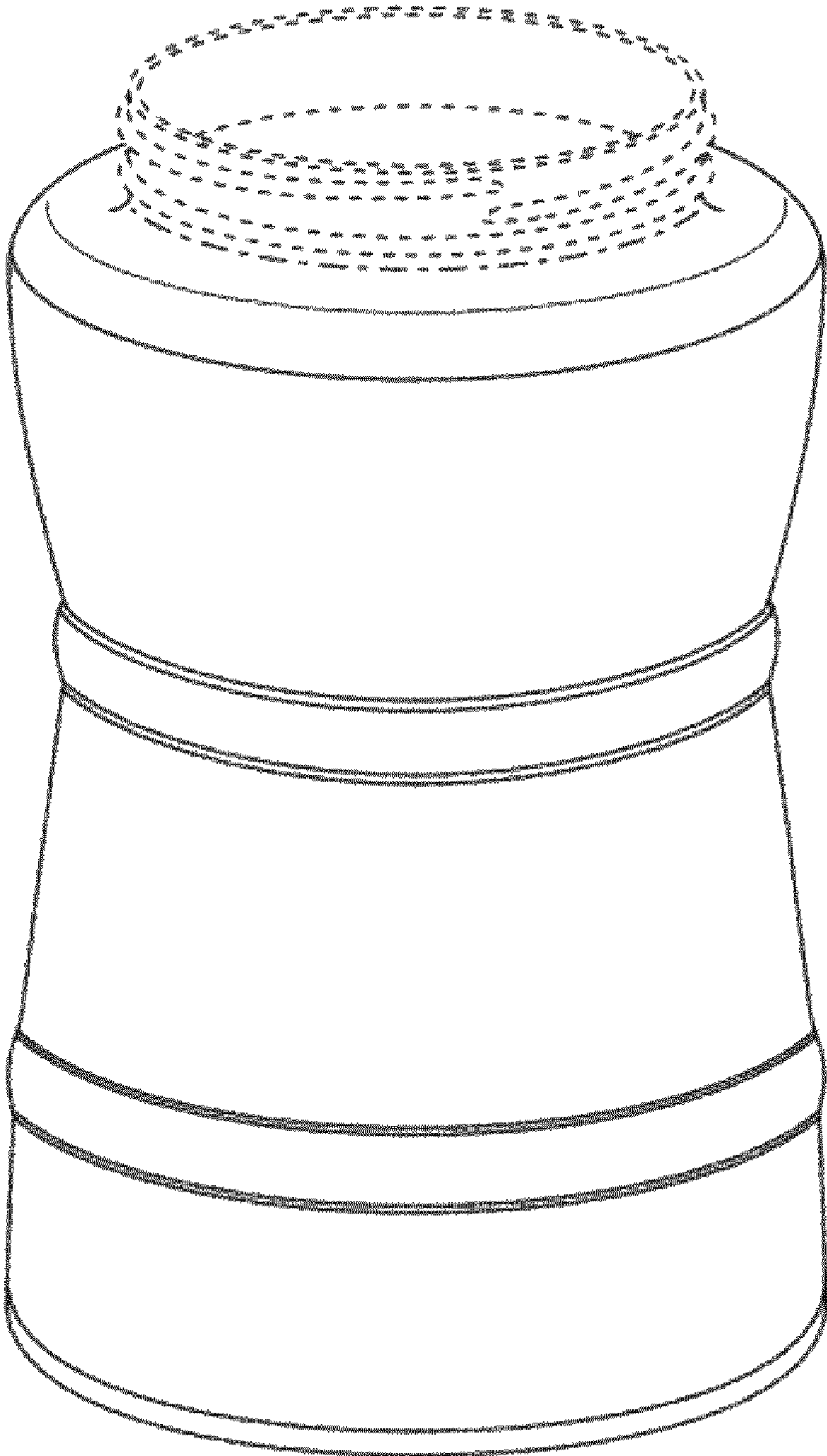

FIG. 1

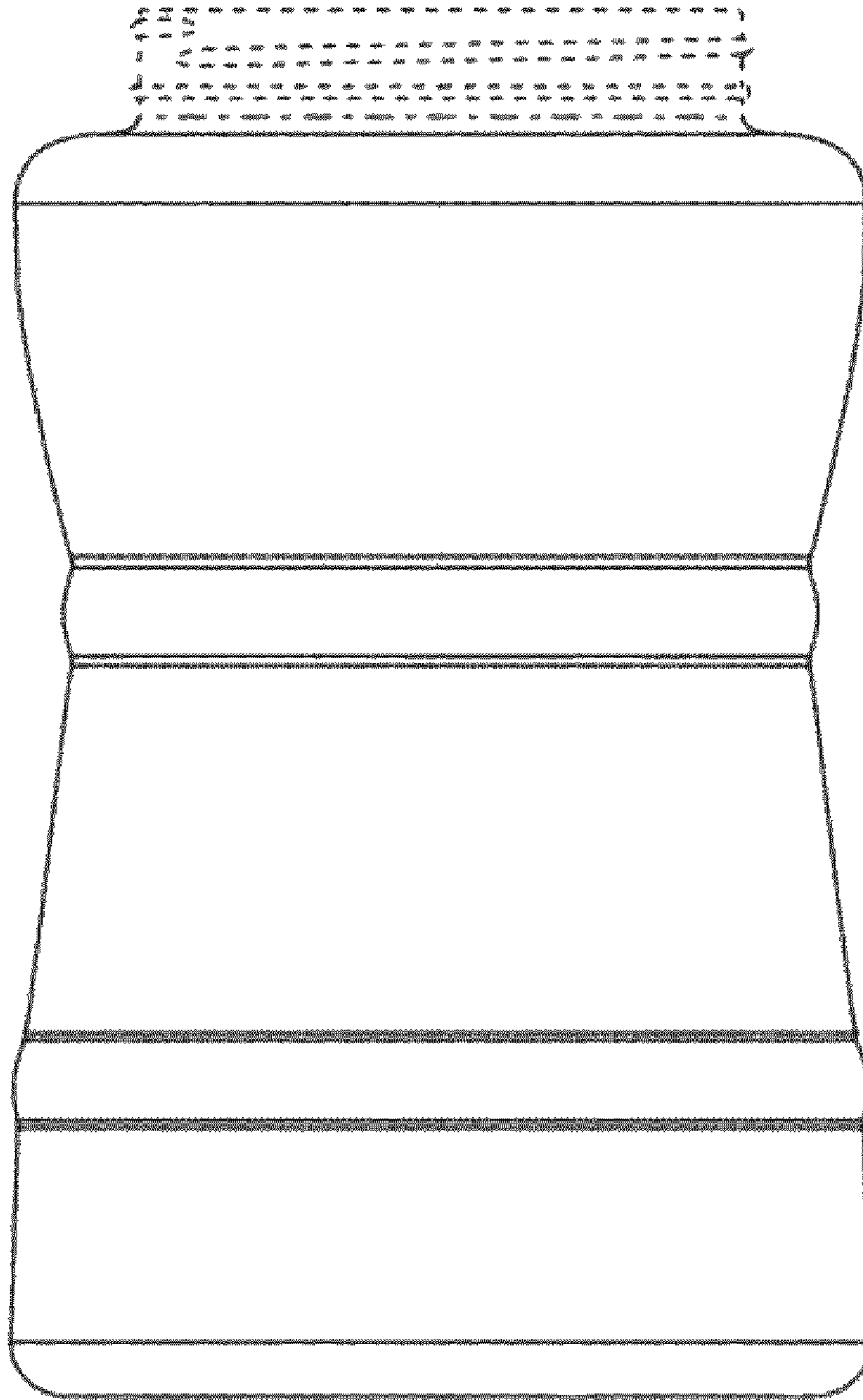

FIG. 2

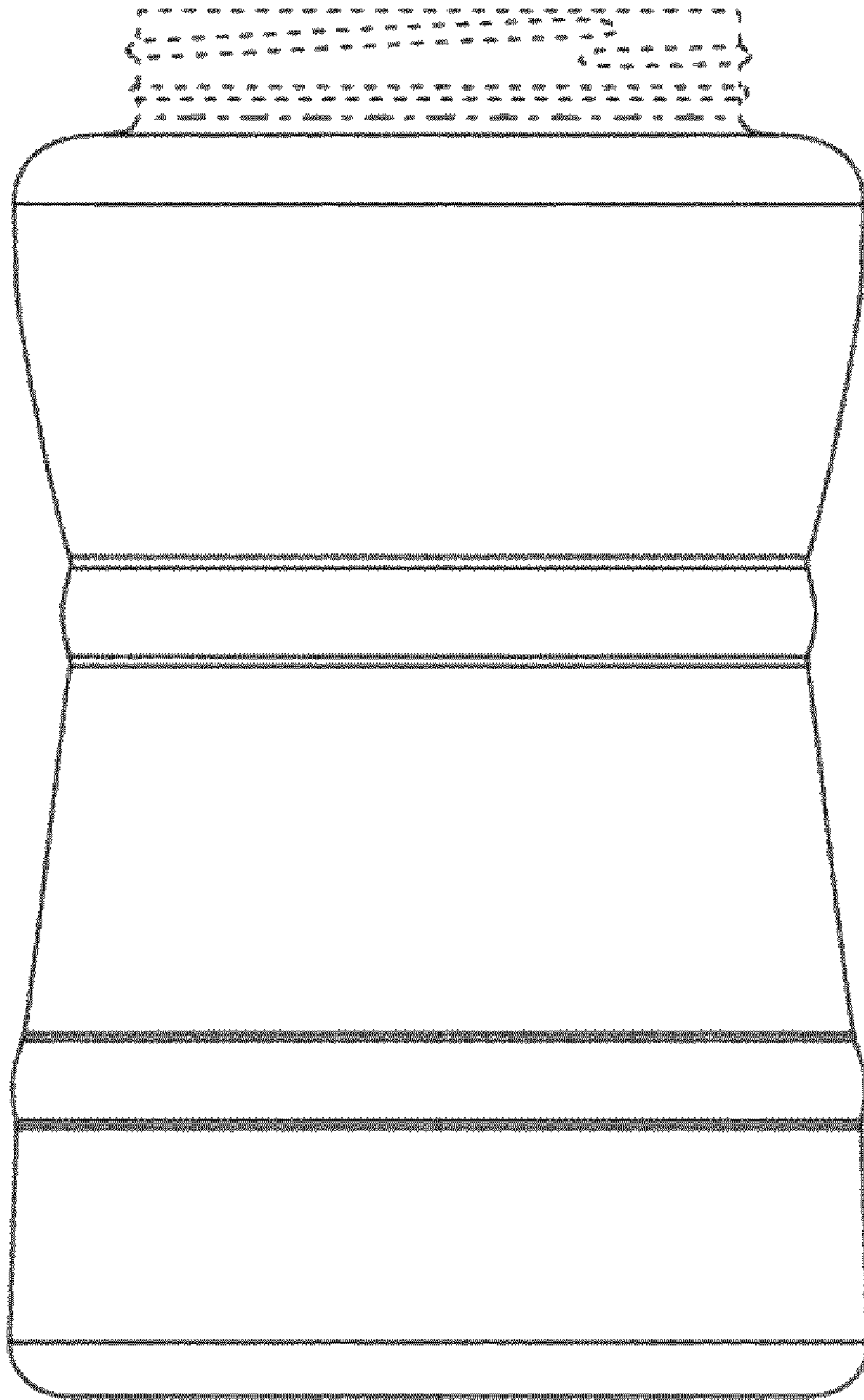

FIG. 3

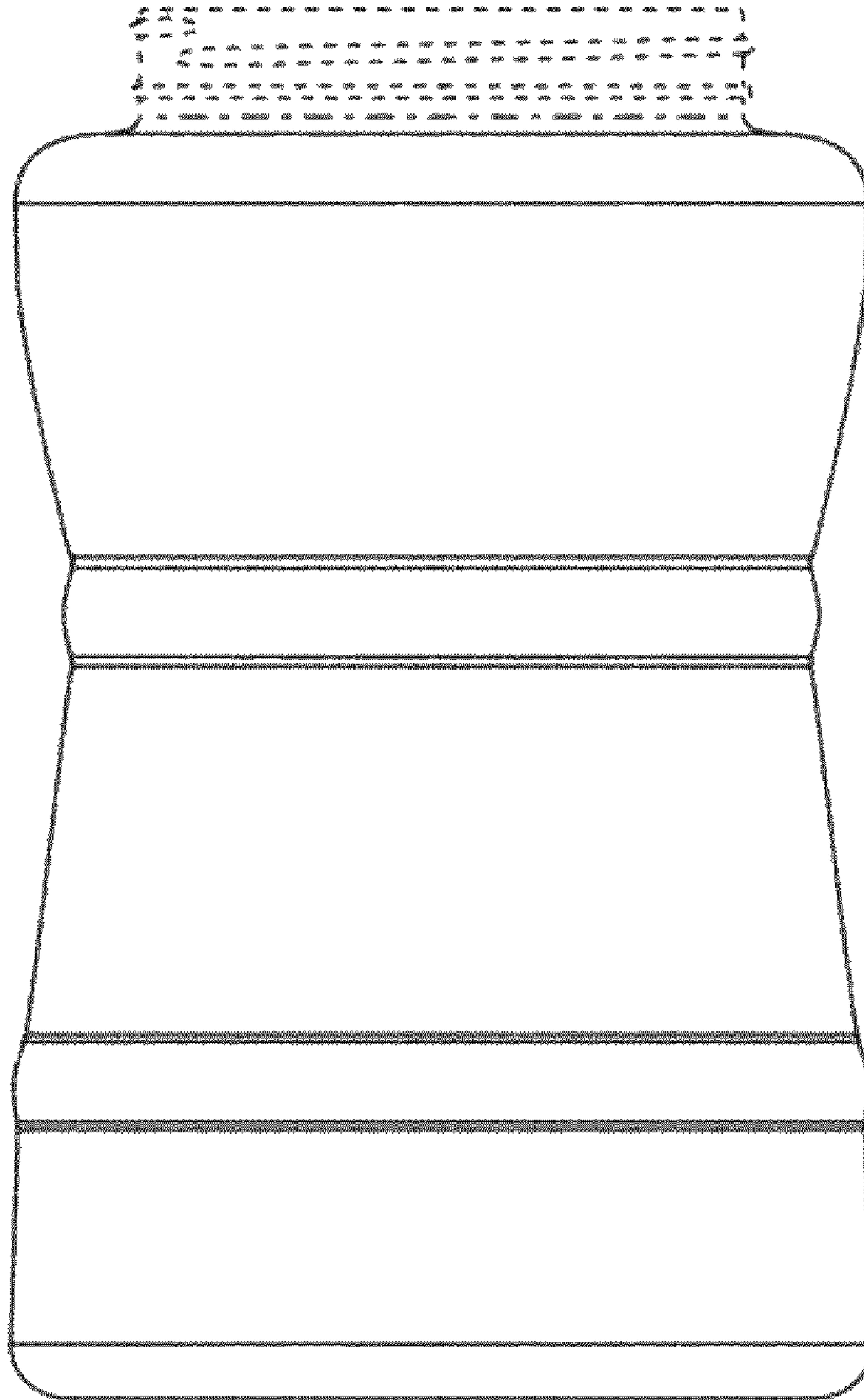

FIG. 4

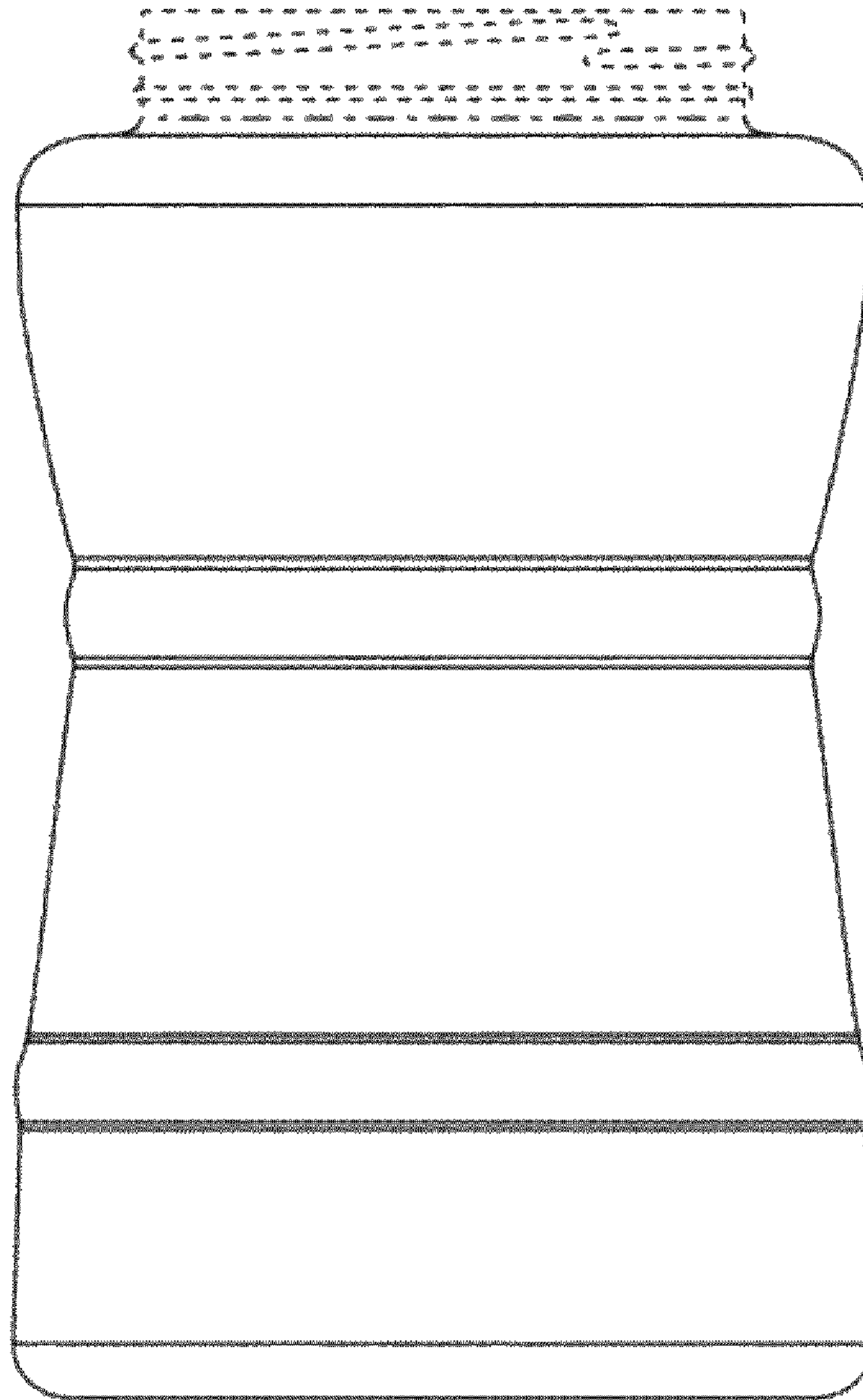

FIG. 5

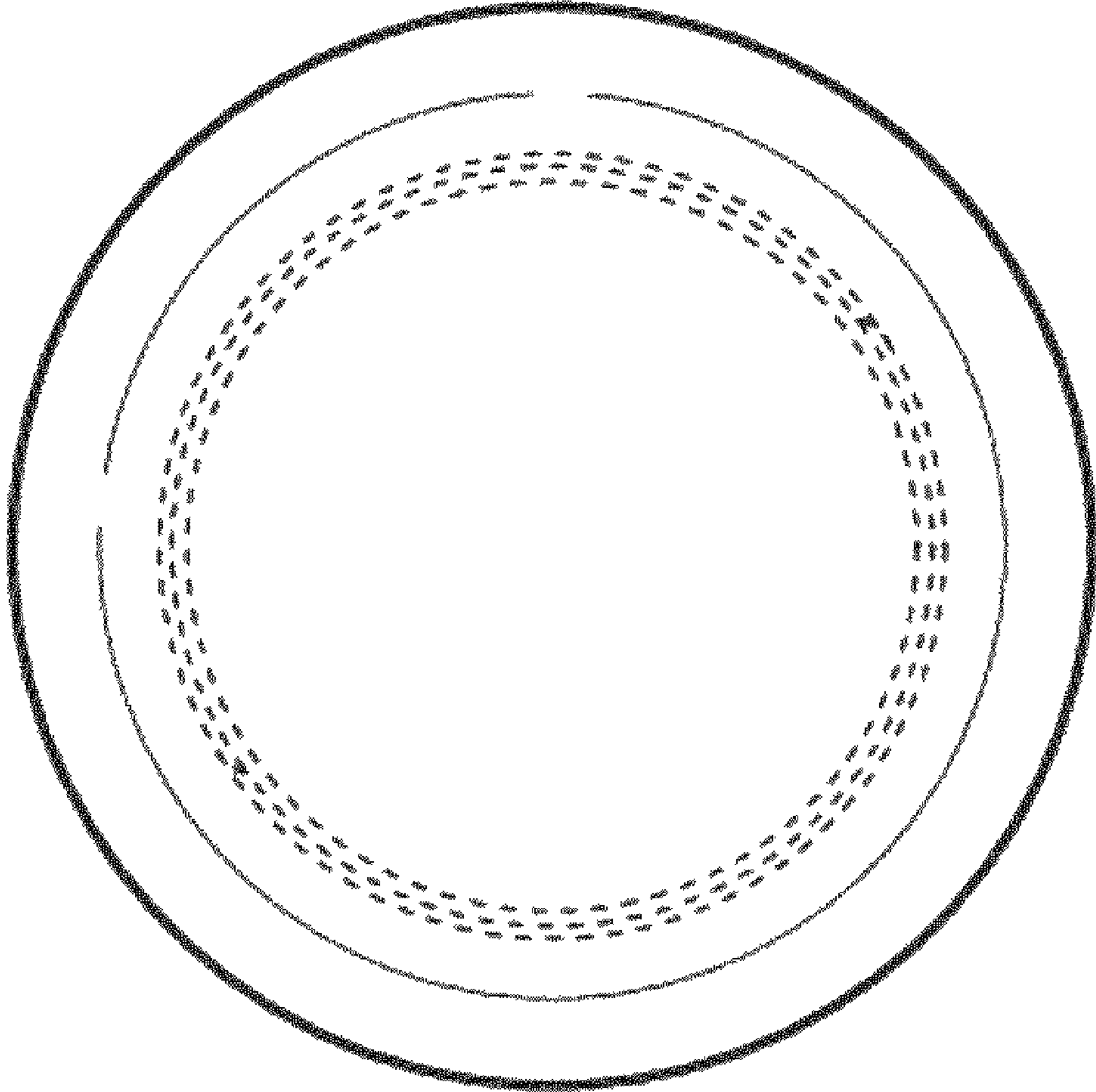

FIG. 6